

**TECHNICAL MANUAL**

**UNIT, INTERMEDIATE DIRECT  
SUPPORT  
AND INTERMEDIATE GENERAL**

<b>INTERMEDIATE DIRECT SUPPORT MAINTENANCE INSTRUCTIONS</b>	<b>3-1</b>
---	------------

**SUPPORT  
MAINTENANCE INSTRUCTIONS**

<b>INTERMEDIATE GENERAL SUPPORT MAINTENANCE INSTRUCTIONS</b>	<b>4-1</b>
--	------------

**LANDING CRAFT, UTILITY  
(LCU)**

<b>APPENDIXES</b>	<b>A-1</b>
-------------------	------------

**NSN 1905-01-154-1191**

<b>ALPHABETICAL INDEX</b>	<b>INDEX 1</b>
-------------------------------	----------------

**BASIC CRAFT  
(PART II)**

<b>This copy is a reprint which includes current ages from Changes 1 and 2.</b>
---

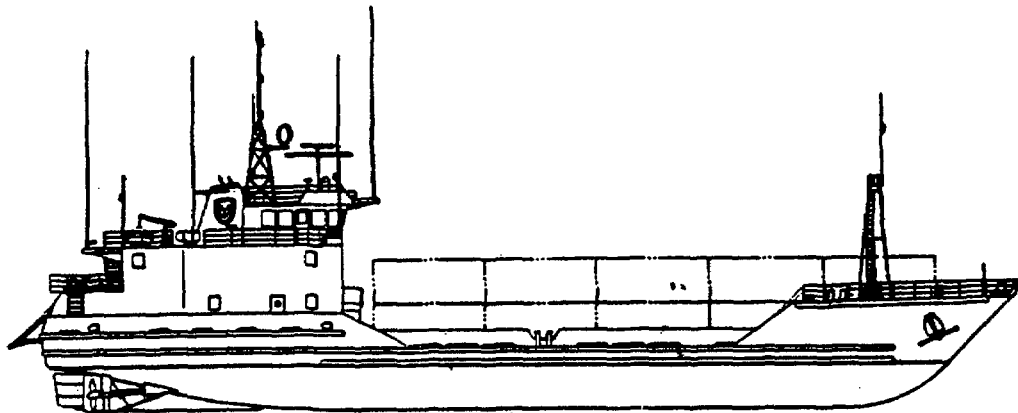

Approved for public release. Distribution is unlimited.

**HEADQUARTERS, DEPARTMENT OF THE ARMY  
17 JANUARY 1989**



CHANGE  
No. 6

HEADQUARTERS  
DEPARTMENT OF THE ARMY  
WASHINGTON, D.C., 15 MAY 2002

Unit, Intermediate Direct Support and Intermediate General Support  
Maintenance Instructions

**LANDING CRAFT, UTILITY (LCU)  
BASIC CRAFT (PART II)  
NSN 1905-01-154-1191**

Approved for public release; Distribution is unlimited.

TM 55-1905-223-24-18-2, 17 January 1989 is changed as follows:

1. Remove and insert pages as indicated below. New or changed text material is indicated by a vertical bar in the margin. An illustration change is indicated by a miniature pointing hand.

Remove page

-----  
i and ii  
3-410.1/(3-410.2 blank)  
3-411.1/(3-411.2 blank)  
3-412.1/(3-412.2 blank)  
3-413 and 3-414  
3-413.1/(3-413.2 blank)  
3-414.1/(3-414.2 blank)  
3-415.1/(3-415.2 blank)  
3-417.1/(3-417.2 blank)  
3-418.1/(3-418.2 blank)  
3-419.1/(3-419.2 blank)  
-----  
-----  
A-1 and A-2  
B-87 through B-89/(B-90 blank)  
-----  
2028's

Insert page

A and B  
i and ii  
-----  
-----  
-----  
3-413/(3-414 blank)  
-----  
3-414.1 through 3-414.4  
-----  
-----  
-----  
-----  
3-416.1 through 3-416.3/(3-416.4 blank)  
3-420.1 and 3-420.2  
A-1 and A-2  
B-87 through B-90  
electronic 2028  
2028's

2. Retain this sheet in front of manual for reference purposes.

**By Order of the Secretary of the Army**

Official:

  
JOEL B. HUDSON  
Administrative Assistant to the  
Secretary of the Army  
0201510

ERIC K. SHINSEKI  
General, United States Army  
Chief of Staff

**DISTRIBUTION:**

To be distributed in accordance with IDN 254813, requirements for TM 55-1905-223-18-2.



CHANGE

NO. 5

HEADQUARTERS  
DEPARTMENT OF THE ARMY  
WASHINGTON, D.C., 28 February 1995

**UNIT, INTERMEDIATE DIRECT SUPPORT  
AND INTERMEDIATE GENERAL SUPPORT  
MAINTENANCE INSTRUCTIONS**

**LANDING CRAFT, UTILITY (LCU)  
NSN 1905-01-154-1191  
BASIC CRAFT (PART II)**

DISTRIBUTION STATEMENT A: Approved for public release; Distribution is unlimited.

TM 55-1905-223-24-18-2, dated 17 January 1989, is changed as follows:

1. Remove and insert pages as indicated below. New or changed text material is indicated by a vertical bar in the margin. An illustration change is indicated by a miniature pointing hand.

Remove pages	Insert pages
i and ii	i and ii
A-1 and A-2	A-1 and A-2
B-27 through B-30	B-27 through B-30

2. Retain this sheet in front of manual for reference purposes.

By Order of the Secretary of the Army:

GORDON R. SULLIVAN  
*General, United States Army*  
*Chief of Staff*

Official:

MILTON H. HAMILTON  
*Administrative Assistant to the*  
*Secretary of the Army*

**DISTRIBUTION:**

To be distributed in accordance with DA Form 12-25-E, block no. 4813, requirements for TM 55-1905-223-24-18-2.



CHANGE

NO. 4

HEADQUARTERS  
DEPARTMENT OF THE ARMY  
WASHINGTON, D.C., 29 JULY 1994

**Unit, Intermediate Direct Support,  
and Intermediate General Support  
Maintenance Instructions  
for  
LANDING CRAFT UTILITY (LCU)  
NSN 1905-01-154-1191  
BASIC CRAFT (PART II)**

DISTRIBUTION STATEMENT A: Approved for public release; distribution is unlimited

TM 55-1905-223-24-18-2, 17 January 1989, is changed as follows:

1. Remove and insert pages as indicated below. New or changed text material is indicated by a vertical bar in the margin. An illustration change is indicated by a miniature pointing hand.

Remove pages	Insert pages
B-7 and B-8	B-7 and B-8
B-43 and B-44	B-43 and B-44
B-77 and B-78	B-77 and B-78
B-81 and B-82	B-81 and B-82
B-89/(B-90 blank)	B-89/(B-90 blank)
C-1 through C-3/(C-4 blank)	C-1 through C-3/(C-4 blank)

2. Retain this sheet in front of manual for reference purposes.

By Order of the Secretary of the Army:

GORDON R. SULLIVAN  
*General, United States Army*  
*Chief of Staff*

Official:

MILTON H. HAMILTON  
*Administrative Assistant to the*  
*Secretary of the Army*  
07131

DISTRIBUTION:

To be distributed in accordance with DA 12-25-E, block no. 4813, requirements for TM 55-1905-223-24-18-2.





CHANGE

NO. 3

HEADQUARTERS  
DEPARTMENT OF THE ARMY  
WASHINGTON, D.C., 9 NOVEMBER 1992**Unit, Intermediate Direct Support and Intermediate General Support  
Maintenance Instructions  
for****LANDING CRAFT, UTILITY (LCU)  
NSN 1905-01-154-1191  
BASIC CRAFT (PART II)**

Approved for public release; Distribution is unlimited

TM 55-1905-223-24-18-2, 17 January 1989 is changed as follows:

1. Remove and insert pages as indicated below. New or changed text material is indicated by a vertical bar in the margin. An illustration change is indicated by a miniature pointing hand.

Remove pages	Insert pages
3-689 and 3-690	3-689 and 3-690

2. Retain this sheet in front of manual for reference purposes.

**By Order of the Secretary of the Army:**

Official:

MILTON H. HAMILTON  
*Administrative Assistant to the  
Secretary of the Army*  
03015GORDON R. SULLIVAN  
*General, United States Army  
Chief of Staff*

DISTRIBUTION:

To be distributed in accordance with DA Form 12-25-E, block no. 4813, requirements for TM 55-1905-223-24-18-2.



CHANGE

NO. 2

HEADQUARTERS  
DEPARTMENT OF THE ARMY  
WASHINGTON, D.C., 30 September 1991

**Unit, Intermediate Direct Support and  
Intermediate General Support Maintenance Instructions**

for

**LANDING CRAFT, UTILITY (LCU)  
NSN 1905-01-154-1191  
BASIC CRAFT (PART II)**

Approved for public release; distribution is unlimited

TM 55-1905-223-2418-2, 17 January 1989, is changed as follows:

1. Remove and insert pages as indicated below. New or changed text material is indicated by a vertical bar in the margin. An illustration change is indicated by a miniature pointing hand.

Remove pages	Insert pages
---	3-410.1/(3-410.2 blank)
---	3-411.1/(3-411.2 blank)
---	3-412.1/(3-412.2 blank)
---	3-413.1/(3-413.2 blank)
---	3-414.1/(3-414.2 blank)
---	3-415.1/(3-415.2 blank)
---	3-417.1/(3-417.2 blank)
---	3-418.1/(3-418.2 blank)
---	3-419.1/(3-419.2 blank)

2. Retain this sheet in front of manual for reference purposes.

By Order of the Secretary of the Army:

GORDON R. SULLIVAN  
*General, United States Army  
Chief of Staff*

Official:

PATRICIA P. HICKERSON  
*Brigadier General, United States Army  
The Adjutant General*

DISTRIBUTION:

To be distributed in accordance with DA Form 12-25E, (qty rqr block no. 4813)



CHANGE

NO. 1

HEADQUARTERS,  
DEPARTMENT OF THE ARMY  
WASHINGTON, D.C., 10 August 1990**Unit, Intermediate Direct Support and  
Intermediate General Support  
Maintenance Instructions**

for

**LANDING CRAFT, UTILITY (LCU)  
NSN 1905-01-154-1191  
BASIC CRAFT (PART II)**

Approved for public release; distribution is unlimited.

TM 55-1905-223-24-18-2, 17 January 1989, is changed as follows:

1. Remove and insert pages as indicated below. New or changed text material is indicated by a vertical bar in the margin. An illustration change is indicated by a miniature pointing hand.

## Remove pages

3-43 and 3-44  
3-47 and 3-48  
3-57 and 3-58  
3-79 through 3-82  
3-95 and 3-96  
3-125 and 3-126  
3-129 and 3-130  
3-133 through 3-136  
3-139 through 3-142  
3-145 and 3-146  
3-205 through 3-208  
3-219 and 3-220  
3-223 and 3-224  
3-239 through 3-242  
3-247 and 3-248  
3-251 through 3-254  
3-257 through 3-262  
3-267 and 3-268  
3-297 through 3-300  
3-305 through 3-308  
3-313 and 3-314  
3-317 through 3-320  
3-323 and 3-324

## Insert pages

3-43 and 3-44  
3-47 and 3-48  
3-57 and 3-58  
3-79 through 3-82  
3-95 and 3-96  
3-125 and 3-126  
3-129 and 3-130  
3-133 through 3-136  
3-139 through 3-142  
3-145 and 3-146  
3-205 through 3-208  
3-219 and 3-220  
3-223 and 3-224  
3-239 through 3-242  
3-247 and 3-248  
3-251 through 3-254  
3-257 through 3-262  
3-267 and 3-268  
3-297 through 3-300  
3-305 through 3-308  
3-313 and 3-314  
3-317 through 3-320  
3-323 and 3-324

## Remove pages

3-327 through 3-332  
3-345 and 3-346  
3-369 and 3-370  
3-381 through 3-384  
3-389 and 3-390  
3-401 and 3-402  
3-405 and 3-406  
3-409 and 3-410  
3-417 and 3-418  
3-421 and 3-422  
3-425 through 3-430  
3-433 and 3-434  
3-437 through 3-444  
3-447 and 3-448  
3-463 and 3-464  
3-467 through 3-470  
3-475 through 3-484  
3-487 through 3-490  
3-495 through 3-506  
3-509 through 3-518  
3-521 through 3-524  
3-531 through 3-548  
3-551 through 3-568  
3-571 through 3-574  
3-577 through 3-588  
3-613 and 3-614  
3-629 and 3-630  
3-633 through 3-638  
3-689 and 3-690  
3-711 through 3-716  
3-719 and 3-720  
3-723 and 3-742  
4-23 and 4-24  
4-33 and 4-34  
4-43 and 4-44  
B-3 through B-92

## Insert pages

3-327 through 3-332  
3-345 and 3-346  
3-369 and 3-370  
3-381 through 3-384  
3-389 and 3-390  
3-401 and 3-402  
3-405 and 3-406  
3-409 and 3-410  
3-417 and 3-418  
3-421 and 3-422  
3-425 through 3-430  
3-433 and 3-434  
3-437 through 3-444  
3-447 and 3-448  
3-463 and 3-464  
3-467 through 3-470  
3-475 through 3-484  
3-487 through 3-490  
3-495 through 3-506  
3-509 through 3-518  
3-521 through 3-524  
3-531 through 3-548  
3-551 through 3-568  
3-571 through 3-574  
3-577 through 3-588  
3-613 and 3-614  
3-629 and 3-630  
3-633 through 3-638  
3-689 and 3-690  
3-711 through 3-716  
3-719 and 3-720  
3-723 and 3-742  
4-23 and 4-24  
4-33 and 4-34  
4-43 and 4-44  
B-3 through B-89/B-90

2. Retain this sheet in front of manual for reference purposes.

By Order of the Secretary of the Army:

CARL E. VUONO  
*General, United States Army*  
*Chief of Staff*

Official:

THOMAS F. SIKORA  
*Brigadier General, United States Army*  
*The Adjutant General*

DISTRIBUTION:

To be distributed in accordance with DA Form 12-25E, Unit and Direct Support and General Support Maintenance requirements for Landing Craft, Utility, LUC-1466, Type III.

INSERT LATEST CHANGED PAGES. DESTROY SUPERSEDED DATA.

**LIST OF EFFECTIVE PAGES**

**NOTE:** The portion of text affected by the changes is indicated by a vertical line in the outer margins of the page. Changes to illustrations are indicated by miniature pointing hands. Changes to wiring diagrams are indicated by shaded areas.

**Dates of issue for original and changed pages are:**

- Original .. 0 .. 17 Jan 1989
- Change .. 1 .. 10 Aug 1990
- Change .. 2 .. 30 Sep 1991
- Change .. 3 .. 09 Nov 1992
- Change .. 4 .. 29 July 1994
- Change .. 5 .. 28 Feb 1995
- Change .. 6 .. 15 May 2002

**TOTAL NUMBER OF PAGES AFFECTED IS 1174 CONSISTING OF THE FOLLOWING:**

Page No.	*Change No.	Page No.	*Change No.
A and B .....	6	3-251 through 3-254.....	1
i and ii .....	6	3-255 and 3-256.....	0
3-1 through 3-42.....	0	3-257 through 3-262.....	1
3-43 and 3-44.....	1	3-263 through 3-266.....	0
3-45 and 3-46.....	0	3-267 and 3-268.....	1
3-47 and 3-48.....	1	3-269 through 3-296.....	0
3-49 through 3-56 .....	0	3-297 through 3-300.....	1
3-57 and 3-58.....	1	3-301 through 3-304.....	0
3-59 through 3-78 .....	0	3-305 through 3-308.....	1
3-79 through 3-82 .....	1	3-309 through 3-312.....	0
3-83 through 3-94 .....	0	3-313 and 3-314 .....	1
3-95and 3-96.....	1	3-315 and 3-316.....	0
3-97 through 3-124 .....	0	3-317 through 3-320.....	1
3-125 and 3-126.....	1	3-321 and 3-322 .....	0
3-127 and 3-128.....	0	3-323 and 3-324 .....	1
3-129 and 3-130.....	1	3-325 and 3-326.....	0
3-131 and 3-132.....	0	3-327 through 3-332.....	1
3-133 through 3-136 .....	1	3-333 through 3-344.....	0
3-137 and 3-138.....	0	3-345 and 3-346.....	1
3-139 through 3-142 .....	1	3-347 through 3-368.....	0
3-143 and 3-144.....	0	3-369 and 3-370.....	1
3-145 and 3-146.....	1	3-371 through 3-380.....	0
3-147 through 3-204 .....	0	3-381 through 3-384.....	1
3-205 through 3-208 .....	1	3-385 through 3-388.....	0
3-209 through 3-218 .....	0	3-389 and 3-390 .....	1
3-219 and 3-220.....	1	3-391 and 3-400.....	0
3-221 and 3-222.....	0	3-401 and 3-402.....	1
3-223 and 3-224.....	1	3-403 and 3-404.....	0
3-225 through 3-238 .....	0	3-405 and 3-406.....	1
3-239 through 3-242 .....	1	3-407 and 3-408.....	2
3-243 through 3-246 .....	0	3-409 through 3-412.....	1
3-247 and 3-248.....	1	3-413/3-414 blank .....	6
3-249 and 3-250.....	0	3-414.1 through 3-414.4 .....	6

\* Zero in this column Indicates an original page.



Page No.	*Change No.	Page No.	*Change No.
3-415 and 3-416.....	0	3-613 and 3-614 .....	1
3-416.1 through 3-416.3/3-416.4 blank ...	6	3-615 through 3-628.....	0
3-417 and 3-418 .....	1	3-629 and 3-630 .....	1
3-419 and 3-420 .....	0	3-631 and 3-632 .....	0
3-420.1 and 3-420.2 .....	6	3-633 through 3-638.....	1
3-421 and 3-422.....	1	3-639 through 3-688.....	0
3-423 and 3-424.....	0	3-689 and 3-690 .....	3
3-425 through 3-430 .....	1	3-691 through 3-710.....	0
3-431 and 3-432.....	0	3-711 through 3-716.....	1
3-433 and 3-434.....	1	3-717 and 3-718 .....	0
3-435 and 3-436.....	0	3-719 and 3-720 .....	1
3-437 through 3-444 .....	1	3-721 and 3-722 .....	0
3-445 and 3-446.....	0	3-723 through 3-742.....	1
3-447 and 3-448.....	1	3-743 through 3-754.....	0
3-449 through 3-462 .....	0	4-1 through 4-22.....	0
3-463 and 3-464.....	1	4-23 and 4-24 .....	1
3-465 and 3-466.....	0	4-25 through 4-32.....	0
3-467 through 3-470 .....	1	4-33 and 4-34 .....	1
3-471 through 3-474 .....	0	4-35 through 4-42 .....	0
3-475 through 3-484 .....	1	4-43 and 4-44 .....	1
3-485 and 3-486.....	0	4-45 through 4-62.....	0
3-487 through 3-490 .....	1	A-1 and A-2 .....	6
3-491 through 3-494 .....	0	B-1 through B-4 .....	0
3-495 through 3-506 .....	1	B-5 and B-6 .....	1
3-507 and 3-508.....	0	B-7 and B-8 .....	4
3-509 through 3-518 .....	1	B-9 through B-26 .....	1
3-519 and 3-520.....	0	B-27 through B-30 .....	5
3-521 through 3-524 .....	1	B-31 through B-80 .....	1
3-525 through 3-530 .....	0	B-81 and B-82 .....	4
3-531 through 3-548 .....	1	B-83 through B-86 .....	1
3-549 and 3-550.....	0	B-87 through B-90 .....	6
3-551 through 3-568 .....	1	C-1 through C-4.....	4
3-569 and 3-570.....	0	D-1 and D-2.....	0
3-571 through 3-574 .....	1	Glossary 1 and Glossary 2.....	0
3-575 and 3-576.....	0	Index 1 through Index 22.....	0
3-577 through 3-588 .....	1	FP-1 through FP-40.....	0
3-589 through 3-612 .....	0	Electronic 2028.....	6
		2028's.....	6

\* Zero in this column indicates an original page.

## INTRODUCTION

This manual is divided into two volumes:

Volume 1, TM 55-1905-223-24-18-1 consists of Chapters 1 and 2.

Volume 2 TM 55-1905-223-14-18-2 consists of Chapters 3 and 4, Appendixes A through D, Glossary and Index.

---

**WARNING**

---

**MODIFICATION HAZARD**

Unauthorized modifications, alterations or installations of or to this equipment are prohibited and are in violation of AR 750-10. Any such unauthorized modifications, alterations or installations could result in death, injury or damage to the equipment.

**HIGH PRESSURE HYDRAULIC SYSTEM HAZARDS**

**Hydraulic systems can cause serious injuries if high pressure lines or equipment fail.**

Never work on hydraulic systems or equipment unless there is another person nearby who is familiar with the operation and hazards of the equipment, and who can give first aid. A second person should stand by controls to turn off hydraulic pumps in an emergency.

**MOVING MACHINERY HAZARDS**

**Be very careful when operating or working near moving machinery.**

Running engines, rotating shafts, and other moving machinery parts could cause personal injury or death.

**ELECTRICAL HAZARDS**

Do not be misled by the term "low voltage." Potentials as low as 50 volts may cause death under adverse conditions. Be careful not to contact 115-Vac input connections when installing operating equipment. Whenever the nature of the operation permits, keep one hand away from the equipment to reduce the hazard of current flowing through the body.

**FLAMMABLE LIQUID AND COMBUSTIBLE VAPOR HAZARDS**

Gasoline, fuel oil, lubricating oil, grease, paint, paint thinner, cleaning solvents and other combustible liquids present a serious fire hazard. Always store combustible liquids in approved containers and in their designated compartments or deck storage locations. Ensure exhaust and ventilation fans are operating while using cleaning solvents or paint products. Never store or charge batteries in a confined space without ventilation or near operating electrical equipment.

When refueling and defueling the vessel, ensure appropriate signs are posted in visible locations and warnings are announced over the vessel's public address system. Smoking, welding and any operation which involves open flames must be prohibited throughout the vessel.

**CAUSTIC AND CORROSIVE CHEMICAL HAZARDS**

Battery acid and water purification chemicals such as bromine and chlorine can cause serious burns to eyes or exposed areas of skin. Always wear eye protection and protective clothing when working with caustic and corrosive chemicals. If chemicals accidentally contact skin or eyes, immediately flush with large quantities of water and seek medical attention.

**COMPRESSED AIR HAZARDS**

High pressure compressed air tanks, piping systems and air operated devices possess potential for serious injury to eyes and exposed areas of skin due to escaping air pressure.

**ELECTROMAGNETIC RADIATION HAZARDS**

Electromagnetic radiation from the searchlight, radar, and radio antennas has the potential for serious radiation burns. Do not stand in the path of radiation emission.

**FIRE SUPPRESSANT HAZARDS**

Fire suppressant chemicals displace oxygen and can cause suffocation. Immediately evacuate areas where they will be used.

**For Artificial Respiration, refer to FM 21-11.**

a/(b blank)



**UNIT, INTERMEDIATE DIRECT SUPPORT  
AND INTERMEDIATE GENERAL SUPPORT  
MAINTENANCE INSTRUCTIONS  
FOR THE  
LANDING CRAFT, UTILITY (LCU) BASIC CRAFT (PART II)  
NSN: 1905-01-154-1191**

**REPORTING ERRORS AND RECOMMENDING IMPROVEMENTS**

You can help improve this publication. If you find any mistakes or if you know of a way to improve the procedures, please let us know. Submit your DA Form 2028 (Recommended Changes to Publications and Blank Forms), through the Internet, on the Army Electronic Product Support (AEPS) website. The Internet address is <http://aeeps.ria.army.mil>. If you need a password, scroll down and click on "ACCESS REQUEST FORM". The DA Form 2028 is located in the ONLINE FORMS PROCESSING section of the AEPS. Fill out the form and click on SUBMIT. Using this form on the AEPS will enable us to respond quicker to your comments and better manage the DA Form 2028 program. You may also mail, fax or email your letter, or DA Form 2028 direct to: AMSTA-LC-CI/TECH PUBS, TACOM-RI, 1 Rock Island Arsenal, Rock Island, IL 61299-7630. The email address is [TACOM-TECH-PUBS@ria.army.mil](mailto:TACOM-TECH-PUBS@ria.army.mil). The fax number is DSN 793-0726 or Commercial (309) 782-0726.

Distribution Statement A: Approved for public release; Distribution is unlimited.

TABLE OF CONTENTS – CONT.

	<u>PAGE</u>
PART 1	
CHAPTER 3	
	INTERMEDIATE DIRECT SUPPORT MAINTENANCE INSTRUCTIONS..... 3-1
Section I	Repair Parts, Special Tools; Test Measurement and Diagnostic Equipment (TMDE); and Support Equipment..... 3-1
Section II	Service Upon Receipt..... 3-1
Section III	Intermediate Direct Support Preventive Maintenance Checks and Services (PMCS)..... 3-2
Section IV	Intermediate Direct Support Troubleshooting..... 3-18
Section V	Intermediate Direct Support Maintenance Procedures..... 3-41
Section VI	Preparation for Storage or Shipment..... 3-750
CHAPTER 4	
	INTERMEDIATE GENERAL SUPPORT MAINTENANCE INSTRUCTIONS..... 4-1
Section I	Repair Parts, Special Tools; Test, Measurement, and Diagnostic Equipment (TMDE)..... 4-1
Section II	Service Upon Receipt..... 4-1
Section III	Intermediate General Support Preventive Maintenance Checks and Services (PMCS)..... 4-2
Section IV	Intermediate General Support Troubleshooting Procedures..... 4-2
Section V	Intermediate General Support Maintenance Procedures..... 4-4
Section VI	Preparation for Storage or Shipment..... 4-62

TABLE OF CONTENTS - CONT

		<u>PAGE</u>
APPENDIX A	REFERENCES .....	A-1
APPENDIX B	MAINTENANCE ALLOCATION CHART .....	B-1
APPENDIX C	EXPENDABLE/DURABLE SUPPLIES AND MATERIALS LIST .....	C-1
APPENDIX D	TORQUE VALUES .....	D-1
GLOSSARY	ABBREVIATIONS AND DEFINITIONS .....	Glossary 1
ALPHABETICAL INDEX .....		Index 1
FOLDOUTS .....		FP – 1

**CHAPTER 3**

**INTERMEDIATE DIRECT SUPPORT MAINTENANCE INSTRUCTIONS**

	Page
Section I. Repair Parts, Special Tools; Test, Measurement, and Diagnostic Equipment (TMDE); and Support Equipment .....	3-1
Section II. Service Upon Receipt .....	3-1
Section III. Intermediate Direct Support Preventive Maintenance Checks and Services (PMCS) .....	3-2
Section IV. Intermediate Direct Support Troubleshooting Procedures.....	3-18
Section V. Intermediate Direct Support Maintenance Procedure .....	3-41
Section VI. Preparation for Storage or Shipment.....	3-753/(3-754blank)

**SECTION I. REPAIR PARTS, SPECIAL TOOLS; TEST, MEASUREMENT, AND DIAGNOSTIC EQUIPMENT (TMDE); AND SUPPORT EQUIPMENT**

**3-1. Common Tools and Equipment.** For authorized common tools and equipment, refer to the Modified Table of Organization and Equipment (MTOE) applicable to your organization.

**3-2. Special Tools; TMDE, and Support Equipment.** For special tools, test, measurement, and diagnostic equipment; and support equipment requirements are listed and illustrated in the Repair Parts and Special Tools list (RPSTL), TM 55-1905-223-24P. These items are also listed in the Maintenance Allocation Chart (MAC), Appendix B of this manual.

**3-3. Repair Parts.** Repair parts are listed and illustrated in the Repair Parts and Special Tools List (RPSTL) TM 55-1905-223-24P.

**SECTION II. SERVICE UPON RECEIPT**

**3-4. Checking Unpacked Equipment.**

- a. Inspect the equipment for damage incurred during shipment. If the equipment has been damaged, report the damage in accordance with the instructions of DA Pam 738-750.
- b. Check the equipment against the packing slip to see if the shipment is complete. Report all discrepancies in accordance with the instructions of DA Pam 738-750.
- c. Check to see whether the equipment has been modified.

- d. Remove protective caps, plugs, inserts, wrappings, and tape when inspection/inventory is completed. Inspect piping openings for damage. Wipe off dirt, grease, or protective films at time of installation.
- e. Remove chocks from resilient mounted components.

**3-5. Initial Setup Procedure.** Includes operational checks and inspections that are not performed for a routing startup. Direct support maintenance personnel will perform initial setup in accordance with the operator's manual, TM 55-1905-223-10.

**3-6. Startup and Shutdown.** For normal startup, and usual or unusual shutdown procedures, refer to the operator's manual, TM 55-1905-223-10.

### **SECTION III. INTERMEDIATE DIRECT SUPPORT PREVENTIVE MAINTENANCE CHECKS AND SERVICES (PMCS)**

**3-7. Explanation of PMCS Table.** PMCS is designed to keep the equipment in good working condition. This is accomplished by performing certain tests, inspections, and services. Table 3-1 lists items to be serviced and the procedures needed to accomplish the PMCS. The Interval listed at the top of the page tells you when to perform a check or service. If needed, PMCS may be performed more frequently than the indicated interval. The "Procedures" column tells you how to perform the required checks and services. If your equipment does not perform as required, see Table 3-2, Troubleshooting. Report any malfunctions or failures on DA Form 2404. In the Item Number column on DA Form 2404, record the appropriate Item Number from the PMCS table.



Table 3-1. Preventive Maintenance Checks and Services

Item No.	Intervals						Items To Be Inspected/Service	Procedures
	D	W	M	Q	S	A		
								<b><u>HALON SYSTEM</u></b>
1							• Halon Tanks	Inspect and service specified in paragraph 3-11.
2							• Carbon Dioxide Cylinders	Inspect and service specified in paragraph 3-11.
								<b><u>SOUND POWERED TELEPHONES</u></b>
3	•						Sound Powered Telephones	a. Test the two way voice capability of sound powered telephones. Select other stations and conduct two-way conversations. b. Check that transmissions and receptions are clear, undistorted and easily understood. c. Test audible and light indicators. On models SELR and SELR the light indicators should light along with the calling signal.
								<b><u>TANK LEVEL INDICATOR SYSTEM</u></b>
4			•				Tank Level Indicator System Receiver Modules	Inspect for loose electrical connections and breakage. Tighten loose connections. Replace defective modules as specified in paragraphs 3-44, 3-45, or 3-46.
5			•				Tank Level Indicator System Meters and Alarm Lights	Inspect for fogging, cracks, large scratches and breakage. Replace defective meters and alarm lights as specified in paragraphs 3-41 or 3-42.

Table 3-1. Preventive Maintenance Checks and Services

Item No.	Intervals						Items To Be Inspected/Service	Procedures
	D - Daily	W - Weekly	M - Monthly	Q - Quarterly	S - Semiannually	A - Annually		
6			•				Tank Level Indicator System Switches	Check switches for proper operation. Replace defective switches as specified in paragraph 3-43.
7			•				Tank Level Indicator System Receptacles	Inspect for tightness, cracks, and breakage. Replace defective receptacles as specified in paragraphs 3-41 through 3-46.
8			•				Level Sight Indicators	Inspect for tightness, leaks, and breakage. Replace defective sight level indicators as specified in paragraphs 3-41 and 3-42.
9					•		Tank Level Indicator System Receiver Module Gasket	<p style="text-align: center;"><b><u>WARNING</u></b></p> <p>Electrocution, serious injury, or equipment damage can result from contact with electricity. Before beginning interior inspection of tank level indicator system, turn electrical power OFF at Panel L102 and lock out or tag to prevent turn-on during inspection.</p> <p>Open cover and inspect gasket for breakage and hardness. If broken or hard, replace as specified in paragraphs 3-41 or 3-42.</p>

**TANK LEVEL INDICATOR SYSTEM - CONT**

**WARNING**

Table 3-1. Preventive Maintenance Checks and Services

Item No.	D - Daily						W - Weekly	M - Monthly	Q - Quarterly	S - Semiannually	A - Annually	Items To Be Inspected/Service	Procedures
	D	W	M	Q	S	A							
9					•							<p><b><u>TANK LEVEL INDICATOR SYSTEM - CONT</u></b></p> <p>NOTE</p> <p>Module Gasket DO NOT secure cover at this time.</p>	
10	-				•							<p>CONT</p> <p>Tank Level Indicator System Terminal Blocks</p> <p>Inspect for tightness and evidence of burning. Replace defective blocks as specified in paragraph 3-41 or 3-42.</p>	
11					•							<p>Tank Level Indicator System Printed Circuit Models and Connectors</p> <p>Inspect for tightness, cracks, and breakage. Replace defective modules and connectors as specified in paragraphs 3-44 and 3-45, or 3-46.</p>	
12					•							<p>Tank Level Indicator System Capacitors</p> <p>Inspect for tightness, cracks, and blisters. Replace defective capacitors as specified in paragraph 3-44 or 3-45, or 3-46.</p>	
13					•							<p>Tank Level Indicator System Transformers</p> <p>Inspect for evidence or burning or swelling and tightness. Replace defective transformers as specified in paragraph 3-44 or 3-45, or 3-46.</p>	

Table 3-1. Preventive Maintenance Checks and Services

Item No.	Intervals						Items To Be Inspected/Service	Procedures
	D	W	M	Q	S	A		
14					•		Tank Level Indicator System Potentiometers	<p align="center"><b><u>TANK LEVEL INDICATOR SYSTEM - CONT</u></b></p> <p>Inspect for corrosion, tightness, and evidence of burning. Replace defective potentiometers as specified in paragraphs 3-41 and 3-42.</p>
15					•		XENON Searchlight Elapsed Time Indicator	<p align="center"><b><u>NAVIGATION SIGNALS AND SEARCHLIGHTS</u></b></p> <p>Check reading. Lamp should be replaced every 1500-1600 hours. See paragraph 3-46.</p>
16							Steering Control System	<p align="center"><b><u>CONTROLS SYSTEMS</u></b></p> <p><b>NOTE: DONE PRIOR TO GETTING UNDERWAY</b></p> <p align="center">NOTE</p> <p>These tests and adjustments should be done prior to getting underway and in the order listed.</p> <p>a. Visual Wiring Check. Check wiring and component mounting for possible causes of damage from vibration, chafing, strain, overheating, and short circuits from loose wires.</p> <p>b. Power Source Check. Check power leads for correct polarity and voltage using a voltmeter.</p> <p>c. Gyrocompass Alignment and Calibration.</p> <p>d. Alignment. After the gyrocompass is restarted, adjust the gyro interface course reference dial to align with</p>

Table 3-1. Preventive Maintenance Checks and Services

D - Daily    W - Weekly    M - Monthly    Q - Quarterly    S - Semiannually    A - Annually

Item No.	Interval						Items To Be Inspected/ Serviced	Procedures
	D	W	M	Q	S	A		
16							<p><b>Steering Control System-CONT</b></p> <p>the main gyrocompass heading. The course reference dial is located inside the gyro interface cabinet. It is adjusted by turning the small knurled brass knob located on the main gear housing.</p> <ol style="list-style-type: none"> <li>(1) Adjust synchro in the Gyro Interface Unit until the course repeater dial on the autopilot aligns with the course indicator dial in the gyro interface unit.</li> <li>(2) Manually rotate the course indicator dial in the Gyro Interface Unit by turning the knurled brass knob on the end of the worm gear shaft to ensure that the autopilot repeater dial turns in the correct direction.</li> <li>(3) If the direction of rotation is incorrect, reverse wires at connections (S1 and S2) on the terminal strip labelled AUTOPILOT in the Gyro Interface Assembly.</li> <li>(4) The gyro must now be started and manually slewed.</li> <li>(5) Observe the direction of rotation of the course indicator dial in the gyro interface unit to ensure that it turns in the same direction as the gyro. If the direction of rotation is incorrect, proceed as follows:               <ol style="list-style-type: none"> <li>(a) For synchro type inputs reverse connections (S1 and S2) on the terminal strip labelled GYRO TRANSMISSION UNIT in the Gyro Interface Unit.</li> </ol> </li> </ol>	

Table 3-1. Preventive Maintenance Checks and Services

D - Daily    W - Weekly    M - Monthly    Q - Quarterly    S - Semiannually    A - Annually

Item No.	Interval						Items To Be Inspected/ Serviced	Procedures
	D	W	M	Q	S	A		
16							Steering Control System - CONT	<p style="text-align: center;"><b><u>CONTROLS SYSTEMS - CONT</u></b></p> <p>(b) For stepper motor type inputs reverse connections 1 and 2 on the terminal strip labelled GYRO TRANSMISSION UNIT in the Gyro Interface Unit.</p> <p>(c) Adjust the gyro interface course indicator dial (by rotating the small knurled brass knob) until it aligns with the master gyrocompass heading.</p> <p>(d) The Autopilot course repeater dial should now indicate the gyrocompass heading.</p> <p>(6) Now calibrate the Gyrocompass input.</p> <p>e. Calibration Procedure for Gyro Input.</p> <p>(1) The compass repeater function should be checked first.</p> <p>(2) Turn the power ON and select NFU.</p> <p>(3) When the repeater dial aligns with the gyro compass, switch to AUTOPILOT mode.</p> <p>(4) Rotate the repeater dial 20 degrees clockwise by hand.</p> <p>(5) Measure the voltage on pin 1 of U9 using +4 volt reference on printed circuit board (PCB) pin 2.</p>

Table 3-1. Preventive Maintenance Checks and Services

D - Daily    W - Weekly    M - Monthly    Q - Quarterly    S - Semiannually    A - Annually

Item No.	Interval						Items To Be Inspected/ Serviced	Procedures
	D	W	M	Q	S	A		
16							<p><b>Steering Control System - CONT</b></p> <p style="text-align: center;"><u>CONTROLS SYSTEMS - CONT</u></p> <p>(6) Adjust voltage regulator (RV1) to obtain 2 volts <math>\pm</math> 0.1V.</p> <p>(7) Rotate the dial 40 degrees counterclockwise and check the output.</p> <p>(8) No adjustments should be made to voltage regulator (RV2). This adjustment for magnetic compass input only.</p> <p>f. Solenoid Polarity.</p> <p>(1) Manually press the Left NFU pushbutton.</p> <p>(2) The rudder should move to Left.</p> <p>(3) Press the Left or Right NFU pushbuttons.</p> <p>(4) If the rudder moves in the wrong direction, reverse wires at terminals 12 and 14 to the #2 Local Control Unit.</p> <p>g. Rudder Angle Indicator (Local Control Unit).</p> <p>(1) Operate the steering gear and observe the rudder angle indicator.</p> <p>(2) If the indicator reads the wrong direction, reverse wires at terminals 18 &amp; 20 to the Local Control Unit.</p>	

Table 3-1. Preventive Maintenance Checks and Services

D - Daily    W - Weekly    M - Monthly    Q - Quarterly    S - Semiannually    A - Annually

Item No.	Interval						Items To Be Inspected/ Serviced	Procedures
	D	W	M	Q	S	A		
16							<p><b>Steering Control System-CONT</b></p> <p style="text-align: center;"><u><b>CONTROLS SYSTEMS - CONT</b></u></p> <p>(3) Adjust the trimpot at the back of the Rudder Angle Indicator for proper indication of rudder angle.</p> <p>h. Local Control Unit Full-Follow-Up Amplifier.</p> <p>(1) Refer to Full-Follow-Up Amplifier for parts location.</p> <p>(2) Recheck that the supply voltage is connected to the correct amplifier terminals and that the correct jumper wires have been connected.</p> <p>(3) Center the rudder and all controllers.</p> <p>(4) Turn on the power to the amplifier.</p> <p>(5) Turn on the hydraulic pumpset or start the engine if any engine driven pumping set is being used.</p> <p>(6) The rudder should stay at midships and may hunt back and forth at the midships position.</p> <p style="text-align: center;">NOTE</p> <p>If the rudder moves to a hardover position, shut off the power to the amplifier and reverse connections 14 and 16 at the amplifier terminals, then turn on power.</p>	



Table 3-1. Preventive Maintenance Checks and Services

D - Daily    W - Weekly    M - Monthly    Q - Quarterly    S - Semiannually    A - Annually

Item No.	Interval						Items To Be Inspected/ Serviced	Procedures
	D	W	M	Q	S	A		
16							Steering Control System-CONT	<p style="text-align: center;"><b><u>CONTROLS SYSTEMS - CONT</u></b></p> <p>(7) Move the controller approximately 20 degrees to port. The rudder should move about half way to port and remain there. If the rudder moves to starboard, reverse the connections at amplifier terminals 7 and 9.</p> <p>(8) Move the controller to center position and adjust the GAIN control found on the amplifier circuit board in a counterclockwise direction until the rudder begins hunting back and forth (if not already doing so).</p> <p>(9) Slowly adjust the GAIN control clockwise until the hunting motion stops. This setting will be the maximum useable gain for the system. This adjustment may require repeating after a few hours of operation since rudder speed may change as the oil heats up or air is expelled for the hydraulic system.</p> <p>(10) Move the controller to center position and confirm that the rudder is centered. If not, adjust the rudder follow-up linkage rod length to correct.</p> <p>i. Full Follow-Up.</p> <p>(1) Select FFU on the Steering Control Panel MODE selector switch and turn the steering wheel.</p>

Table 3-1. Preventive Maintenance Checks and Services

D - Daily    W - Weekly    M - Monthly    Q - Quarterly    S - Semiannually    A - Annually

Item No.	Interval						Items To Be Inspected/ Serviced	Procedures
	D	W	M	Q	S	A		
16							Steering Control System-CONT	<p style="text-align: center;"><u>CONTROLS SYSTEMS - CONT</u></p> <p>(2) Check for correct direction.</p> <p>j. External Rudder Indicators.</p> <p>(1) If any external rudder angle indicators move in the wrong direction, reverse the two meter wires at the appropriate station.</p> <p>k. Autopilot Trim and Counter Rudder Setting.</p> <p>(1) Use Autopilot (Trim Switch Setting) to locate the Automatic Trim DP (Dual In-line Pin) switches 1, 3, 4 and 5 - Counter Rudder switch 2 (SW2) and pot control voltage regulator (RV5).</p> <p>(2) Other controls on the board are factory preset and should not be touched.</p> <p>(3) The information in the table below can be used as a starting point for setting the trim and counter rudder time constants.</p> <p>(4) 'C' indicates that the rocker switches are closed when depressed on the numbered side.</p> <p>(5) '0' indicates that the rocker switches are open when depressed on the blankd side of the switch.</p> <p>(6) The 'Normal' setting, as shown, on the table, should be used when uncertain if the rudder response is normal or slow.</p>

Table 3-1. Preventive Maintenance Checks and Services

D - Daily    W - Weekly    M - Monthly    Q - Quarterly    S - Semiannually    A - Annually

Item No.	Interval						Items To Be Inspected/ Serviced	Procedures																																																																																									
	D	W	M	Q	S	A																																																																																											
16							Steering Control System-CONT	<p style="text-align: center;"><b><u>CONTROLS SYSTEMS - CONT</u></b></p> <table border="1"> <thead> <tr> <th rowspan="2">SHIP LENGTH IN METRES</th> <th rowspan="2">RUDDER RESPONSE</th> <th colspan="4">AUTOMATIC TRIM</th> <th colspan="2">COUNTER RUDDER</th> </tr> <tr> <th>SW1</th> <th>SW3</th> <th>SW4</th> <th>SW5</th> <th>SW2</th> <th>RV5</th> </tr> </thead> <tbody> <tr> <td rowspan="2">UNDER 15</td> <td>NORMAL</td> <td>O</td> <td>C</td> <td>C</td> <td>C</td> <td>C</td> <td>10-50</td> </tr> <tr> <td>SLOW</td> <td>O</td> <td>O</td> <td>C</td> <td>C</td> <td>C</td> <td>20-100</td> </tr> <tr> <td rowspan="2">15 TO 30</td> <td>NORMAL</td> <td>O</td> <td>O</td> <td>C</td> <td>C</td> <td>C</td> <td>20-100</td> </tr> <tr> <td>SLOW</td> <td>O</td> <td>O</td> <td>O</td> <td>C</td> <td>O</td> <td>0-30</td> </tr> <tr> <td rowspan="2">30 TO 60</td> <td>NORMAL</td> <td>O</td> <td>O</td> <td>O</td> <td>C</td> <td>C</td> <td>50-100</td> </tr> <tr> <td>SLOW</td> <td>C</td> <td>O</td> <td>O</td> <td>C</td> <td>O</td> <td>0-50</td> </tr> <tr> <td rowspan="2">60 TO 120</td> <td>NORMAL</td> <td>C</td> <td>O</td> <td>O</td> <td>C</td> <td>C</td> <td>70-100</td> </tr> <tr> <td>SLOW</td> <td>C</td> <td>C</td> <td>C</td> <td>O</td> <td>O</td> <td>0-30</td> </tr> <tr> <td rowspan="2">OVER 120</td> <td>NORMAL</td> <td>C</td> <td>O</td> <td>O</td> <td>O</td> <td>O</td> <td>0-30</td> </tr> <tr> <td>SLOW</td> <td>C</td> <td>O</td> <td>O</td> <td>O</td> <td>O</td> <td>20-100</td> </tr> </tbody> </table> <p style="text-align: right;">10193</p> <p style="text-align: center;">Trim Switch Settings</p> <ol style="list-style-type: none"> <li>1. Helm.             <ol style="list-style-type: none"> <li>(1) A trimming potentiometer is supplied with each main potentiometer.</li> <li>(2) When controlling the steering gear, the trim pot should be adjusted so that the steering gear stops a few degrees before either hardover position.</li> </ol> </li> </ol>	SHIP LENGTH IN METRES	RUDDER RESPONSE	AUTOMATIC TRIM				COUNTER RUDDER		SW1	SW3	SW4	SW5	SW2	RV5	UNDER 15	NORMAL	O	C	C	C	C	10-50	SLOW	O	O	C	C	C	20-100	15 TO 30	NORMAL	O	O	C	C	C	20-100	SLOW	O	O	O	C	O	0-30	30 TO 60	NORMAL	O	O	O	C	C	50-100	SLOW	C	O	O	C	O	0-50	60 TO 120	NORMAL	C	O	O	C	C	70-100	SLOW	C	C	C	O	O	0-30	OVER 120	NORMAL	C	O	O	O	O	0-30	SLOW	C	O	O	O	O	20-100
SHIP LENGTH IN METRES	RUDDER RESPONSE	AUTOMATIC TRIM				COUNTER RUDDER																																																																																											
		SW1	SW3	SW4	SW5	SW2	RV5																																																																																										
UNDER 15	NORMAL	O	C	C	C	C	10-50																																																																																										
	SLOW	O	O	C	C	C	20-100																																																																																										
15 TO 30	NORMAL	O	O	C	C	C	20-100																																																																																										
	SLOW	O	O	O	C	O	0-30																																																																																										
30 TO 60	NORMAL	O	O	O	C	C	50-100																																																																																										
	SLOW	C	O	O	C	O	0-50																																																																																										
60 TO 120	NORMAL	C	O	O	C	C	70-100																																																																																										
	SLOW	C	C	C	O	O	0-30																																																																																										
OVER 120	NORMAL	C	O	O	O	O	0-30																																																																																										
	SLOW	C	O	O	O	O	20-100																																																																																										

Table 3-1. Preventive Maintenance Checks and Services

D - Daily    W - Weekly    M - Monthly    Q - Quarterly    S - Semiannually    A - Annually

Item No.	Interval						Items To Be Inspected/ Serviced	Procedures
	D	W	M	Q	S	A		
16							Steering Control System-CONT	<p align="center"><b><u>CONTROLS SYSTEMS - CONT</u></b></p> <p>(3) When controlling a Rudder Order Indicator, the trim pot can regulate the full scale deflection.</p> <p>(4) When using the helm with the steering gear operating, the steering amplifier gain control must be adjusted to prevent the steering gear from oscillating (hunting) back and forth.</p> <p>(5) The gain control is turned fully clockwise, then slowly returned counterclockwise until the steering gear stops hunting. The FFU amplifier main circuit board inside the Local Control Unit.</p> <p>(6) The control is labelled GAIN and can be located on the FFU amplifier main circuit board inside the Local Control Unit.</p>
17							Autopilot	<p align="center"><b><u>CONTROLS SYSTEM</u></b></p> <p><b>NOTE: DONE AT SEA AFTER GETTING UNDERWAY.</b></p> <p align="center">NOTE</p> <p>These tests and adjustments should be done underway in fairly calm sea conditions and in the order listed.</p> <p>a. Special Notice.</p>

Table 3-1. Preventive Maintenance Checks and Services

D - Daily    W - Weekly    M - Monthly    Q - Quarterly    S - Semiannually    A - Annually

Item No.	Interval						Items To Be Inspected/ Serviced	Procedures
	D	W	M	Q	S	A		
17							Autopilot-CONT	<p style="text-align: center;"><u>CONTROLS SYSTEM</u></p> <p>(1) An Autopilot is not intended to take the place of the pilot, but rather assist in steering the vessel.</p> <p>(2) It is the responsibility of the main (and a requirement by law) to ensure and maintain safe navigation and control of the vessel at all times in accordance with the Rules of the Road.</p> <p>(3) An Autopilot is intended for operation in open waters, clear of all obstructions and other vessels.</p> <p>(4) It may be necessary to regain manual steering control quickly and to deactivate the Autopilot Pumpset if the vessel alters or fails to maintain the set course or if the set course may jeopardize the vessel.</p> <p>b. Pre-Test Requirements.</p> <p>(1) These tests would be performed under fairly calm sea conditions with minimal wind or tide.</p> <p>(2) If wind or tide conditions are unavailable, set a course to minimize effects on the following testing and set-up procedures to ensure correct settings.</p>

Table 3-1. Preventive Maintenance Checks and Services

D - Daily    W - Weekly    M - Monthly    Q - Quarterly    S - Semiannually    A - Annually

Item No.	Interval						Items To Be Inspected/ Serviced	Procedures
	D	W	M	Q	S	A		
17							Autopilot - CONT	<p style="text-align: center;"><u>CONTROLS SYSTEM - CONT</u></p> <p>c. Rudder Angle Indicators Centered.</p> <p>(1) Steer the vessel by hand on a fixed heading. The Rudder Angle Indicator should indicate zero angle.</p> <p>(2) If the Rudder Angle Indicator displays any angle other than 0°, the follow-up linkage should be adjusted until the meter reads 0°.</p> <p>(3) Proper adjustment will ensure a smooth transition from manual to autopilot steering.</p> <p>d. Counter Rudder Settings.</p> <p>(1) The purpose of the counter rudder feature is to stop (or counter) the over-rotation of the vessel caused by inertia during course changes or wave motion.</p> <p>(2) Vessels of the same length vary widely in steering response and inertia effects, depending on speed, loading, hull shape, and rudder design.</p> <p>(3) Internal controls counter rudder switch 2 and voltage regulator (RV5) Trim Switch Settings set the length of time the counter rudder is applied.</p>

Table 3-1. Preventive Maintenance Checks and Services

D - Daily    W - Weekly    M - Monthly    Q - Quarterly    S - Semiannually    A - Annually

Item No.	Interval						Items To Be Inspected/ Serviced	Procedures
	D	W	M	Q	S	A		
17	*						Autopilot - CONT	<p style="text-align: center;"><u>CONTROLS SYSTEM - CONT</u></p> <p>(a) To optimize these settings, make small course changes of 30 degrees to the left or right at cruising speed with the counter rudder control on the panel set at 10 o'clock and observe the over-swing when coming on to the new course.</p> <p>(b) Reduce the over-swing to minimum by increasing the time constant on the internal controls, then adjust the panel control.</p> <p>(c) Increasing either the time constant or the amount of counter rudder to high may cause sustained oscillation back and forth about the new course.</p> <p>(4) The external control sets the amount of counter rudder applied.</p> <p>(a) A high setting may cause the vessel to momentarily stop or turn too slowly as it approaches the new course. If this happens, turn the front panel control counterclockwise.</p>

Table 3-1. Preventive Maintenance Checks and Services

D - Daily    W - Weekly    M - Monthly    Q - Quarterly    S - Semiannually    A - Annually

Item No.	Interval						Items To Be Inspected/ Serviced	Procedures																																																																																									
	D	W	M	Q	S	A																																																																																											
17							Autopilot - CONT	<p align="center"><b><u>CONTROLS SYSTEM - CONT</u></b></p> <table border="1"> <thead> <tr> <th rowspan="2">SHIP LENGTH IN METRES</th> <th rowspan="2">RUDDER RESPONSE</th> <th colspan="4">AUTOMATIC TRIM</th> <th colspan="2">COUNTER RUDDER</th> </tr> <tr> <th>SW1</th> <th>SW3</th> <th>SW4</th> <th>SW5</th> <th>SW2</th> <th>RV5</th> </tr> </thead> <tbody> <tr> <td rowspan="2">UNDER 15</td> <td>NORMAL</td> <td>O</td> <td>C</td> <td>C</td> <td>C</td> <td>C</td> <td>10-50</td> </tr> <tr> <td>SLOW</td> <td>O</td> <td>O</td> <td>C</td> <td>C</td> <td>C</td> <td>20-100</td> </tr> <tr> <td rowspan="2">15 TO 30</td> <td>NORMAL</td> <td>O</td> <td>O</td> <td>C</td> <td>C</td> <td>C</td> <td>20-100</td> </tr> <tr> <td>SLOW</td> <td>O</td> <td>O</td> <td>O</td> <td>C</td> <td>O</td> <td>0-30</td> </tr> <tr> <td rowspan="2">30 TO 60</td> <td>NORMAL</td> <td>O</td> <td>O</td> <td>O</td> <td>C</td> <td>C</td> <td>50-100</td> </tr> <tr> <td>SLOW</td> <td>C</td> <td>O</td> <td>O</td> <td>C</td> <td>O</td> <td>0-50</td> </tr> <tr> <td rowspan="2">60 TO 120</td> <td>NORMAL</td> <td>C</td> <td>O</td> <td>O</td> <td>C</td> <td>C</td> <td>70-100</td> </tr> <tr> <td>SLOW</td> <td>C</td> <td>C</td> <td>C</td> <td>O</td> <td>O</td> <td>0-30</td> </tr> <tr> <td rowspan="2">OVER 120</td> <td>NORMAL</td> <td>C</td> <td>O</td> <td>O</td> <td>O</td> <td>O</td> <td>0-30</td> </tr> <tr> <td>SLOW</td> <td>C</td> <td>O</td> <td>O</td> <td>O</td> <td>O</td> <td>20-100</td> </tr> </tbody> </table> <p align="center"><b>TRIM SWITCH SETTINGS</b></p>	SHIP LENGTH IN METRES	RUDDER RESPONSE	AUTOMATIC TRIM				COUNTER RUDDER		SW1	SW3	SW4	SW5	SW2	RV5	UNDER 15	NORMAL	O	C	C	C	C	10-50	SLOW	O	O	C	C	C	20-100	15 TO 30	NORMAL	O	O	C	C	C	20-100	SLOW	O	O	O	C	O	0-30	30 TO 60	NORMAL	O	O	O	C	C	50-100	SLOW	C	O	O	C	O	0-50	60 TO 120	NORMAL	C	O	O	C	C	70-100	SLOW	C	C	C	O	O	0-30	OVER 120	NORMAL	C	O	O	O	O	0-30	SLOW	C	O	O	O	O	20-100
SHIP LENGTH IN METRES	RUDDER RESPONSE	AUTOMATIC TRIM				COUNTER RUDDER																																																																																											
		SW1	SW3	SW4	SW5	SW2	RV5																																																																																										
UNDER 15	NORMAL	O	C	C	C	C	10-50																																																																																										
	SLOW	O	O	C	C	C	20-100																																																																																										
15 TO 30	NORMAL	O	O	C	C	C	20-100																																																																																										
	SLOW	O	O	O	C	O	0-30																																																																																										
30 TO 60	NORMAL	O	O	O	C	C	50-100																																																																																										
	SLOW	C	O	O	C	O	0-50																																																																																										
60 TO 120	NORMAL	C	O	O	C	C	70-100																																																																																										
	SLOW	C	C	C	O	O	0-30																																																																																										
OVER 120	NORMAL	C	O	O	O	O	0-30																																																																																										
	SLOW	C	O	O	O	O	20-100																																																																																										
18	•						Engine Order Telegraph	<ol style="list-style-type: none"> <li>a. Visually check light lens for illumination.</li> <li>b. Manually check all push switches.</li> <li>c. Check to ensure all cables and EOT are securely connected.</li> </ol>																																																																																									
19					•		Fire Detection System	<ol style="list-style-type: none"> <li>a. Inspect all detectors for dust accumulations.                             <ol style="list-style-type: none"> <li>(1) Clean as required.</li> </ol> </li> </ol>																																																																																									



Table 3-1. Preventive Maintenance Checks and Services

D - Daily    W - Weekly    M - Monthly    Q - Quarterly    S - Semiannually    A - Annually

Item No.	Interval						Items To Be Inspected/ Serviced	Procedures
	D	W	M	Q	S	A		
19					•		Fire Detection System - CONT	<p>b. Activate a detector or alarm initiating device. Check that proper alarm and zone indications are given by the control panel.</p> <p>c. Check the supervisory circuits by operating the RESET/ LAMP TEST switch to the RESET position.</p> <p>(1) Visual indicators on the control panel and modules should light and trouble horn should sound.</p> <p>a. Check operation of each detector/alarm initiating device on all circuits.</p>

**Section IV. INTERMEDIATE DIRECT SUPPORT TROUBLESHOOTING**

3-8. Symptom Index. Both a symptom index and a troubleshooting table are provided. The symptom index will help you locate the information you need for troubleshooting.

<b>SYMPTOM INDEX</b>	
	Troubleshooting Procedure (Table 3-2)
<b>AUTOPILOT</b>	
Autopilot system does not operate or operates erratically	Item 53
<b>DRYER</b>	
Motor does not run	Item 41
Motor does not stop when door is open	Item 42
Heating element shuts off prematurely	Item 43
Heating element does not shut off	Item 44
Motor runs but cylinder does not turn	Item 45
Heating element does not heat	Item 46
<b>ELECTRIC RANGE</b>	
Oven no heating	Item 27
<b>ENGINE ORDER TELEGRAPH</b>	
Error messages	Item 49
Light lenses not illuminated	Item 48
<b>FIRE DETECTION SYSTEM</b>	
Constant alarm on fire detection control panel	Item 54
<b>GYRO INTERFACE ASSEMBLY</b>	
Erratic autopilot operation or course repeater dial on autopilot moves erratically or gives spurious nulls	Item 44
<b>HALON SYSTEM</b>	
Cylinder won't operate	Item 2
System won't operate	Item 1
Time delay won't operate properly	Item 4
Alarms do not operate	Item 3
Does not operate properly	Item 5
<b>LUBE OIL PURIFIER</b>	
Bowl won't reach rated speed	Item 6
Bowl slow to reach speed	Item 6
Separator out of balance	Item 7

**SYMPTOM INDEX - CONT**

Troubleshooting  
Procedure  
(Table 3-2)

**MACHINE SHOP - ARC WELDER**

Oil leak (capacitor)	Item 16
Melted sealer at bottom of housing	Item 17
Reduced high frequency output	Item 18
High frequency output (outage)	Item 19
Auxiliary power (outage)	Item 20

**MACHINERY PLANT MONITORING AND ALARM SYSTEM**

Error messages	Item 51
Message "PROGRAMMING SENSOR, PLEASE WAIT."	Item 50

**NAVIGATION - SEARCHLIGHTS**

Lamp flashes won't start	Item 13
Lamp won't start	Item 14
Low output from power supply	Item 15
No output from power supply	Item 15

**OIL WATER SEPARATOR**

Inoperate when pump switch and power switch turned on	Item 8
---	--------

**POTABLE WATER PIPING SYSTEM**

Low discharge pressure	Item 63
No discharge pressure	Item 64
Storage tank bulging	Item 65
Hot water heater	Item 66

**PROPELLER AND SHAFT ASSEMBLY EXPANDER TUBE BRAKE**

Shaft brake drags (does not disengage fully)	Item 61
Shaft brake slips when locked	Item 62
Shaft brake will not disengage	Item 60
Shaft brake will not engage	Item 59

**REFRIGERATORS AND FREEZERS**

Freezer does not automatically defrost	Item 25
Freezer does not cool	Item 26
High head pressure	Item 24
Low head pressure	Item 23
Unit continues to run	Item 22
Unit does not operate	Item 21

**ROTARY WINDOW**

Rotating screen does not turn at all	Item 55
Unit fogs or ices up during use	Item 56

**SYMPTOM INDEX - CONT**

Troubleshooting  
Procedure  
(Table 3-2)

ROTARY WINDOW (Cont'd)	
Unit vibrates excessively	Item 57
Control box is defective	Item 58
<b>RUDDER ANGLE INDICATOR</b>	
Rudder angle indicator does not operate	Item 52
<b>SOLID WASTE COMPACTOR</b>	
Drawer will not open	Item 30
Drive motor runs but ram does not move	Item 28
Unit operates but is noisy	Item 29
Unit will not shut off	Item 31
<b>SOUND POWERED TELEPHONES</b>	
Indicator lamp does not work	Item 11
Won't receive ring	Item 10
Won't transmit ring	Item 9
<b>TANK LEVEL INDICATOR</b>	
Receiver module meters not working	Item 12
<b>WASHER MACHINE</b>	
Constant agitation	Item 40
Excessive vibration	Item 35
No agitation	Item 32
No cold water	Item 33
No hot water	Item 34
Slow/No spin	Item 38
Water fill won't stop	Item 37
Unit starts cycle then stops	Item 36
Timer does not advance	Item 39

3-9. **Troubleshooting.** Table 3-2 lists the common fault conditions that may be found during operation or maintenance of the equipment. Look for causes and do corrective actions in the order listed. This manual cannot list every symptom that may show up, and it cannot list all of the possible causes and corrective actions. If a symptom is not listed, or if it keeps up after you have performed the corrective actions, notify your supervisor.

**Table 3-2. Troubleshooting**

<b>MALFUNCTION</b>	<b>TEST OR INSPECTION</b>	<b>CORRECTIVE ACTION</b>
--------------------	---------------------------	--------------------------

HALON SYSTEM

1. Halon system does not operate.
  - STEP 1. Check for defective valve on CO<sub>2</sub> actuator.  
Replace valve (para. 3-13).
  - STEP 2. Check for defective time delay.  
Replace time delay (para. 3-13).
  - STEP 3. Check for defective globe valve.  
Replace defective globe valve, para. 3-13.
  
2. Individual halon cylinder does not operate.
  - STEP 1. Check for defective valve actuator on halon tank is defective.  
Replace actuator (para. 3-13).
  - STEP 2. Check for defective halon tank valve.  
Replace halon tank valve (para. 3-13).
  
3. Ventilation does not secure or alarms do not operate when pneumatic switches are actuated.
  - STEP 1. Check for defective pneumatic switch.  
Replace pneumatic switch (para. 3-13).
  
4. Time delay not operating properly.
  - STEP 1. Check for defective time delay.  
Replace time delay (para. 3-13).
  
5. System does not operate properly.
  - STEP 1. Check for defective actuator or discharge piping and/or damaged nozzles.  
Inspect piping and nozzles for clogging or damage.

Table 3-2. Troubleshooting-CONT

MALFUNCTION	TEST OR INSPECTION	CORRECTIVE ACTION
-------------	--------------------	-------------------

LUBE OIL PURIFIER

6. Bowl does not come up to rated speed or is slow to come up to rated speed.

STEP 1. Check for dirty frame under bowl.

Remove bowl assembly (para. 3-16). Clean frame.

STEP 2. Check for loose clamp plate on worm wheel.

Tighten bolts on worm wheel (para. 3-17).

7. Separator runs out of balance.

STEP 1. Check for incorrectly assembled bowl.

Assemble bowl correctly (para. 3-16).

STEP 2. Check for loose bowl lock ring.

Tighten bowl lock ring (para. 3-16).

OIL/WATER SEPARATOR.

8. Oil water separator inoperative when pump switch. and power switch turned on.

STEP 1. Check for defective motor control box assembly.

Repair motor control box assembly, para. 2-26.

STEP 2. Check for defective motorized oil and water pumps.

Repair motorized pump, para. 3-22.

STEP 3. Check for defective control module assembly.

Repair control module assembly, para. 2-28.

SOUND POWERED TELEPHONES

9. Telephone won't transmit ring to other telephones.

STEP 1. Check for defective generator.

Replace generator (para. 3-34 through 3-40).

10. Telephone won't receive ring.

STEP 1. Check for defective relay inside housing, by selecting home station and cranking generator.

Replace relay (para. 3-34 through 3-51:).

**Table 3-2. Troubleshooting-CONT**

MALFUNCTION	TEST OR INSPECTION	CORRECTIVE ACTION
-------------	--------------------	-------------------

SOUND POWERED TELEPHONES - CONT

STEP 2. Check for defective bell, buzzer or horn.  
 Replace bell, buzzer or horn (para. 3-34, 3-35, 3-36, 3-38 or 3-39).

11. Indicator light on telephone doesn't work.

STEP 1. Check for defective bulb.  
 Replace bulb (para. 3-35, 3-37, or 3-40).

STEP 2. Check for defective latching relay.  
 Select home station and crank the generator. Replace relay (para. 3-34 through 3-40).

STEP 3. Check for defective pilotlight.  
 Replace pilotlight (para. 3-35, 3-37, or 3-40).

STEP 4. Check for defective hook switch or pushbutton switch.  
 Replace defective switch (para. 3-35, 3-37, or 3-40).

TANK LEVEL INDICATOR

12. Receiver module meters not operating.

STEP 1. Check for defective fuse.  
 Replace fuse (para. 3-44).

STEP 2. Check for defective circuit card.  
 Replace circuit card (para. 3-44).

STEP 3. Check for defective float switch.  
 Repair/replace float switch (para. 3-43).

STEP 4. Check for defective power supply.  
 Replace power supply (para. 3-44).

STEP 5. Check for defective receiver module.  
 Repair/replace receiver module (para. 3-44).

NAVIGATION - SEARCHLIGHTS

13. Lamp flashes internally without starting.

STEP 1. Check for bad lamp.  
 Replace lamp (para. 3-47).

Table 3-2. Troubleshooting-CONT

MALFUNCTION	TEST OR INSPECTION	CORRECTIVE ACTION
-------------	--------------------	-------------------

NAVIGATION - SEARCHLIGHTS - CONT

STEP 2. Check for bad rectifier in power supply.  
Replace rectifier (para. 3-50).

STEP 3. Check for bad transformer in power supply.  
Replace transformer (para. 3-50).

14. Lamp fails to start with no internal flashing.

STEP 1. Check for faulty door interlock switch.  
Replace door switch (para. 3-47).

**WARNING**

Dangerous voltage is present at starter connections. Use care in this area.

STEP 2. Check for faulty starter by replacement.  
Replace starter (para. 3-49).

STEP 3. Check for faulty transformer.  
Replace transformer (para. 3-49).

15. Low or no output from power supply.

STEP 1. Check for defective fuse.  
Replace fuse (para. 3-50).

STEP 2. Check for defective rectifier, capacitor or transformer. Disconnect the outgoing negative DC wire lead at the terminal block in the power supply. Do not disconnect the positive lead because if the positive and negative leads are reversed the lamp will be instantly destroyed.

Measure the no load DC output voltage of the rectifier at the + and -terminal blocks which should be between 77-140 volts depending upon AC input and transformer settings. Power supply must be energized and contactor closed; however, do not energize lamp starter (i.e. do not keep control station switch in START position) while taking this measurement.

If DC voltage is considerably lower than 77 volts, rectifier, capacitor 1, or one or more transformers may be defective.

Disconnect capacitor 1 and measure DC output as stated above. A short circuited capacitor will cause reduced DC output.



Table 3-2. Troubleshooting-CONT

MALFUNCTION	TEST OR INSPECTION	CORRECTIVE ACTION
-------------	--------------------	-------------------

NAVIGATION - SEARCHLIGHTS - CONT

Disconnect transformer (T1, T2, T3) secondaries by removing all connections at X and Y on the terminal block on one of the three transformers. Use a 0-100 range voltmeter, measure the secondary voltage at X-Y, and record the reading. Reconnect these connections at X and Y and remove connections at X and Y on another transformer, disconnect third transformer, and record its voltage output. The voltages of the three transformers should be essentially the same -- within two or three volts of each other. If one of the voltages is considerably different from the other two that transformer is probably defective.

If all three transformers and capacitor 1 prove to be OK and DC is considerably lower than 77 volts, rectifier is probably defective and should be replaced.  
Replace rectifier, capacitor or transformer (para. 3-50).

MACHINE SHOP - ARC WELDER

16. Oil leak (capacitor).

STEP 1. Check for burned out capacitor. Bench test suspected component.  
Replace as required (para. 3-54).

17. Melted sealer at bottom of housing.

STEP 1. Check for burned out high voltage capacitor. Bench test suspect component.  
Replace as required (para. 3-54).

18. Reduced high frequency output.

STEP 1. Check if feedback is due to faulty bypass filter. Replace cracked or leaking capacitor(s) (para. 3-54 and 3-55).

19. High frequency output (outage).

STEP 1. Check panel switch setting. Must be on START or CONTINUOUS.  
Switch to correct setting.

STEP 2. Spark gaps wrong.  
Check and reset (.008) (PMCS Table 2-1).

STEP 3. Check for high voltage transformer broken leads.  
Replace transformer (para. 3-54).

**Table 3-2. Troubleshooting-CONT**

<b>MALFUNCTION</b>	<b>TEST OR INSPECTION</b>	<b>CORRECTIVE ACTION</b>
--------------------	---------------------------	--------------------------

MACHINE SHOP - ARC WELDER - CONT

STEP 4. Check for faulty high frequency switch.  
Replace (para. 3-56).

STEP 5. Check for faulty capacitor(s).  
Replace (para. 3-55).

20. Auxiliary power (outage).

STEP 1. Check for component overload.  
Reduce load to 10 amperes.

STEP 2. Check for component short.  
Replace faulty component (para. 3-35).

REFRIGERATORS AND FREEZERS

21. Unit does not operate

STEP 1. With multimeter, check circuit breaker.  
Reset/Replace circuit breaker (para. 3-77).

STEP 2. With multimeter, check capacitor.  
Replace capacitor (para. 3-77).

STEP 3. Check compressor.  
Replace compressor.

22. Unit continues to run.

STEP 1. Check condenser fan running.  
Replace condenser fan motor (para. 3-77).

23. Low head pressure.

STEP 1. Check compressor operating.  
Replace compressor (para. 3-77).

STEP 2. Check refrigerant.  
Service as required.

24. High head pressure.

STEP 1. Check for air in system.  
Evacuate, change filter dryer, and recharge.

Table 3-2. Troubleshooting-CONT

MALFUNCTION	TEST OR INSPECTION	CORRECTIVE ACTION
-------------	--------------------	-------------------

REFRIGERATORS AND FREEZERS - CONT

STEP 2. Check for overcharged refrigerant.  
Service as required, (para. 2-69).

25. Freezer goes not automatically defrost

STEP 1. Check for defective defrost timer.  
Replace defrost timer, (para. 3-80).

26. Freezer does not cool.

STEP 1. Check refrigerant pressure at service valve connects.  
If pressure is low, replace compressor, (para. 3-77).

STEP 2. Check for defective condenser fan motor.  
Replace defective fan motor, (para. 3-77).

STEP 3. Check for defective evaporator fan motor.  
Replace evaporator fan motor, (para. 3-78).

ELECTRIC RANGE

27. Oven not heating.

STEP 1. Check for defective thermostatic switch.  
Replace thermostatic switch (para. 3-60).

SOLID WASTE COMPACTOR

28. Drive motor runs but ram does not move.

STEP 1. Check for broken drive chain.  
Replace drive chain (para. 3-83).

STEP 2. Check drive socket roll pin sheared.  
Replace roll pin (para. 3-83).

STEP 3. Check for stripped ram power nuts.  
Replace ram power nuts (para. 3-83).

STEP 4. With multimeter, check directional switch.  
Adjust or replace defective switch, (para. 3-90).

Table 3-2. Troubleshooting-CONT

MALFUNCTION	TEST OR INSPECTION	CORRECTIVE ACTION
-------------	--------------------	-------------------

SOLID WASTE COMPACTOR - CONT

29. Unit operates but is noisy.

STEP 1. Check adjustment of drive chain.  
Adjust drive chain. Should have 1/4" deflection.

STEP 2. Check lubrication of power screws and triangle bearing.  
Lubricate as required.

30. Drawer will not open. (Ram is part way down).

STEP 1. Check for broken chain.  
Replace chain (para. 3-83).

STEP 2. Check door or drawer safety switch with multimeter  
Replace defective switch(es), para. 3-90.

31. Unit will not shut off.

STEP 1. Check top limit switch with multimeter.  
Replace top limit switch (para. 3-83).

STEP 2. Check start/stop switch with multimeter  
Replace start/stop switch (para. 3-83).

WASHER MACHINE

32. No agitation.

STEP 1. Check drive belt.  
Adjust or replace (para. 3-102).

STEP 2. Check for sheared motor pulley drive pin.  
Remove motor and replace drive pin (para. 3-102).

STEP 3. Check for binding in pump.  
Clean or replace pump (para. 3-100).

STEP 4. Check that timer advances.  
Replace timer if defective (para. 3-92).

STEP 5. Check sensitive switch.  
Replace switch if defective (para. 3-92).

STEP 6. Check pressure switch.  
Replace switch if defective (para. 3-92).

Table 3-2. Troubleshooting-CONT

MALFUNCTION	TEST OR INSPECTION	CORRECTIVE ACTION
-------------	--------------------	-------------------

WASHER MACHINE - CONT

- STEP 7. Check door switch.  
Replace switch (para. 3-92).
- STEP 8. Check motor.  
Replace motor if defective (para. 3-102).
- STEP 9. Check for operating transmission.  
Replace transmission (para. 3-99).
33. No cold water.
- STEP 1. Check cold water mixing valve solenoid.  
Replace solenoid if defective (para. 3-93).
- STEP 2. Check cold water supply hose.  
Straighten or replace supply hose (para. 3-100).
- STEP 3. Clogged mixing valve screen.  
Clean or replace screen (para. 3-93).
- STEP 4. Check that timer advances.  
Replace timer if defective (para. 3-92).
- STEP 5. Check temperature switch.  
Replace switch if defective (para. 3-92).
- STEP 6. Check pressure switch.  
Replace switch if defective (para. 3-92).
- STEP 7. Check loose or broken wires.  
Replace or tighten wires.
34. No hot water.
- STEP 1. Check hot water mixing valve solenoid.  
Replace solenoid if defective (para. 3-93).
- STEP 2. Check hot water supply hose.  
Straighten or replace supply hose (para. 3-100).
- STEP 3. Clogged mixing valve screen.  
Clean or replace screen (para. 3-93).
- STEP 4. Check timer.  
Replace timer if defective (para. 3-92).

Table 3-2. Troubleshooting - CONT

MALFUNCTION	TEST OR INSPECTION	CORRECTIVE ACTION
-------------	--------------------	-------------------

WASHER MACHINE - CONT

- STEP 5. Check temperature switch.  
Replace switch if defective (para. 3-92).
- STEP 6. Check pressure switch.  
Replace switch if defective (para. 3-92).
35. Excessive vibration.
- STEP 1. Check centering springs.  
Connect or replace springs (para. 3-95).
36. Unit starts cycle then stops.
- STEP 1. Check top limit switch with multimeter.  
Replace defective switch (para. 3-90).
37. Water fill won't stop.
- STEP 1. Check pressure switch.  
Replace switch if defective (para. 3-92).
- STEP 2. Check timer.  
Replace timer if defective (para. 3-92).
- STEP 3. Check for leaks in pressure hose.  
Replace pressure hose (para. 3-95).
38. Slow or no spin.
- STEP 1. Check for loose or broken drive belt.  
Replace belts (para. 3-107).
- STEP 2. Check brake pads.  
Replace brake pads (para. 3-97).
- STEP 3. Check for binding water pump.  
Replace water pump (para. 3-100).
- STEP 4. Check drive motor  
Replace motor if defective (para. 3-102).
- STEP 5. Check timer  
Replace timer if defective (para. 3-92).

Table 3-2. Troubleshooting-CONT

MALFUNCTION	TEST OR INSPECTION	CORRECTIVE ACTION
-------------	--------------------	-------------------

WASHER MACHINE - CONT

39. Timer does not advance.

STEP 1. Check timer with multimeter.  
Replace timer if defective (para. 3-92).

STEP 2. Check pressure switch.  
Replace switch if defective (para. 3-92).

40. Constant agitation.

STEP 1. Check timer.  
Replace timer if defective (para. 3-92).

STEP 2. Check electrical wiring.  
Replace as required.

DRYER

41. Motor does not run.

STEP 1. Check door switch.  
Replace switch if defective (para. 3-103).

STEP 2. Check motor push switch.  
Replace switch if defective (para. 3-103).

STEP 3. Check motor.  
Replace motor if defective (para. 3-107).

STEP 4. Check timer.  
Replace timer if defective (para. 3-92).

42. Motor does not stop when door is open.

STEP 1. Check door switch with multimeter.  
Replace door switch (para. 3-92).

43. Heater element does not heat or shuts off prematurely.

STEP 1. Check timer with multimeter.  
Replace timer if defective (para. 3-103).

STEP 2. Check for air leak around loading door.  
Replace seal or catch (para. 3-103).

Table 3-2. Troubleshooting-CONT

MALFUNCTION	TEST OR INSPECTION	CORRECTIVE ACTION
-------------	--------------------	-------------------

DRYER - CONT

- STEP 3. Check limit thermostat.  
Replace thermostat (para. 3-103).
- STEP 4. Check for air leak at front or rear cylinder seal.  
Replace cylinder seal (para. 3-104).
44. Heating element does not shut off.
- STEP 1. Check thermostat switch with multimeter.  
Replace switch (para. 3-107).
45. Motor runs but cylinder does not turn.
- STEP 1. Check motor drive pulley.  
Tighten setscrew.
- STEP 2. Check cylinder belt.  
Replace belt para. 3-107).
- STEP 3. Check idler lever spring.  
Connect or replace spring (para. 2-93).
46. Heating element does not heat.
- STEP 1. Check heating element.  
Replace heating element if defective (para. 3-106).
- STEP 2. Check limit thermostat.  
Replace thermostat if defective (para. 3-103).
- STEP 3. Check exhaust fan for proper installation.  
Correct as required (para. 3-107).
- STEP 4. Check drive motor.  
Replace motor if defective (para. 3-107).

GYRO INTERFACE ASSEMBLY

47. Erratic autopilot operation or course repeater dial on autopilot moves erratically or gives spurious nulls.
- STEP 1. Listen for noisy synchro transmitter.  
Replace gyro interface unit (para. 3-115).



Table 3-2. Troubleshooting-CONT

<b>MALFUNCTION</b> <b>TEST OR INSPECTION</b> <b>CORRECTIVE ACTION</b>
---

ENGINE ORDER TELEGRAPH

48. Light lenses not illuminated on engine room panels or bridge panel.

STEP 1. Visually inspect bulbs on panel.  
 Replace bulbs (para. 2-143 and 2-128).

STEP 2. Manually depress all push switches to ensure operation.  
 Replace push switches (para. 3-133).

49. Error messages.

**NOTE**

In the normal process of continual self-test, the system will occasionally detect a problem that may or may not be obvious to the user. The chart below shows the standard messages and problem cause.

Message	Cause	Possible Remedy
Buss shorted	Data cable is damaged	Repair/replace CPU (para. 3-135)
Bad Master	Master card is defective	Replace card (para. 3-135)
Bad memory	Defective memory circuitry	Cycle power
Reset remote	System has forgotten the	Cycle power
Display	Remote display	

MACHINERY PLANT MONITORING AND ALARM SYSTEM

50. Message "PROGRAMMING SENSOR, PLEASE WAIT."

STEP 1. Use a voltmeter to check for 24 VDC power from generator remote module. See analog remote module 24 VDC input wiring diagram.  
 Replace generator remote module, para. 3-81.

51. Error Messages.

**NOTE**

In the normal process of continual self-test, the system will occasionally detect a problem that may or may not be obvious to the user. The chart below shows the standard error messages and probable cause.

Table 3-2. Troubleshooting-CONT

MALFUNCTION	TEST OR INSPECTION	CORRECTIVE ACTION
-------------	--------------------	-------------------

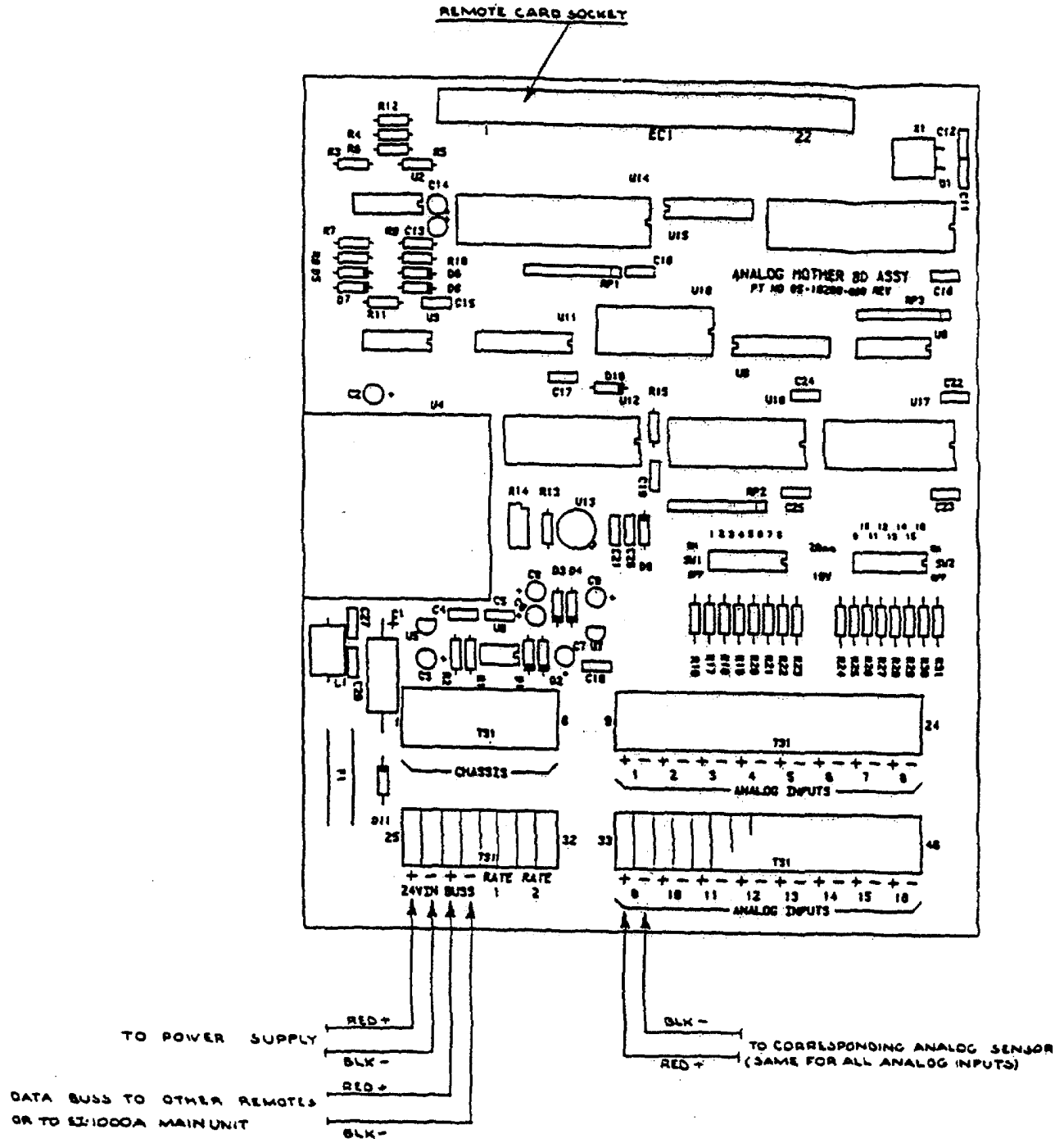

Analog Remote Module 24 VDC Input Wiring Diagram.

Table 3-2. Troubleshooting-CONT

<b>MALFUNCTION TEST OR INSPECTION CORRECTIVE ACTION</b>		
Message	Cause	Possible Remedy
Buss "A" shorted	Data cable is damaged	Repair/replace CPU 3-125
Buss "B" shorted	Data cable is damaged	Repair/replace CPU 3-125
Bad master	Master card is defective	Replace, 3-125
Bad memory	Defective memory circuitry	Cycle power

RUDDER ANGLE INDICATOR

52. Rudder Angle Indicator does not operate.

- STEP 1. Check for defective rudder angle indicator.  
Replace/repair rudder angle indicator (para. 3-118).
- STEP 2. Check for defective junction box assembly.  
Replace/repair junction box assembly (para. 3-119).

AUTOPILOT

53. Autopilot system does not operate or operates erratically.

- STEP 1. Check for incorrect or disconnected wiring.  
Tighten all wiring connections.
- STEP 2. Check for defective autopilot assembly.  
Replace/repair autopilot assembly (para. 3-117).

FIRE DETECTION SYSTEM

54. Constant alarm on fire detection control panel.

- STEP 1. Check for defective thermostatic switch.  
Replace/thermostatic switch (para. 2-119).
- STEP 2. Check for defective fire detection control panel.  
Repair/replace fire detection control panel (para. 3-139).
- STEP 3. Check for defective switchboard alarm panel.  
Repair/replace shipboard alarm panel (para. 3-115).

Table 3-2. Troubleshooting-CONT

MALFUNCTION	TEST OR INSPECTION	CORRECTIVE ACTION
-------------	--------------------	-------------------

ROTARY WINDOW

55. Rotating screen does not turn at all.

STEP 1. Check MOTOR switch.  
Should be in ON position.

STEP 2. Check MOTOR circuit breaker.  
a. Button should be press in.  
b. If not, wait 90 seconds, then press it in.  
c. If it doesn't stay in, unplug the connector on top of the junction box and repeat step b. above.  
d. If it stays in, the motor is defective. Replace motor (para. 3-193).  
e. If not, the control box is defective.

STEP 3. Check the motor brushes.  
Refer to PMCS for procedures.

STEP 4. Check the shaft jam nuts.  
Use two 9/16-inch wrenches to tighten them.

STEP 5. Check for 115 Vac on power connector pins D and E.  
a. If voltage is not present, control box is defective.  
b. If voltage is present, motor is defective. Replace motor (para. 3-193).

STEP 6. Check to be sure spinning frame is not jammed.  
a. Rotate spinning frame by hand; nonresistance should be felt.  
b. If there is resistance, remove spinning frame (para. 3-193).  
c. Clean surfaces and spaces between the two frames, and reassemble.

56. Unit fogs or ices up during use.

STEP 1. Check HEATER switch.  
Should be in ON position.

STEP 2. Check HEATER circuit breaker.  
a. If button stays in, heater is defective. Replace heater (para. 3-193).  
b. If not, control box is defective, refer to malfunction 58.

STEP 3. Check for 115 Vac on power connector pins B and C.  
a. If voltage is not present, control box is defective, refer to malfunction 58.  
b. If voltage is present, heater is defective. Replace heater (para. 3-193).

Table 3-2. Troubleshooting - CONT

MALFUNCTION	TEST OR INSPECTION	CORRECTIVE ACTION
-------------	--------------------	-------------------

## ROTARY WINDOW - CONT

STEP 4. Check air chamber drain holes.

- a. Remove spinning frame assembly (para. 3-193). Dry out entire chamber with a soft clean cloth.
- b. Check drain holes in the bottom of the fixed frame. Holes should be free of obstructions. If holes are plugged up, clean out both holes with a small piece of wire. Be sure holes are entirely clean before reassembly. Remount spinning frame.

57. Unit vibrates excessively.

STEP 1. Check motor shaft taper for dirt, corrosion, etc.

Remove spinning frame from motor shaft, clean shaft and inside of tapered hole, remount spinning frame assembly (para. 3-193).

STEP 2. If unit still vibrates.

Replace spinning frame assembly (para. 3-193).

58. Control box is defective.

**NOTE**

Turn both switches OFF before proceeding.

STEP 1. Check for 115 Vac across terminals 1 and 2.

If voltage is not present, ship's wiring is defective. Refer to ELECTRICAL TROUBLESHOOTING.

STEP 2. Be sure a MOTOR circuit breaker is depressed. Check for 115 Vac across points A and B.

If voltage is not present, motor circuit breaker is defective. Replace motor circuit breaker.

STEP 3. Be sure HEATER circuit breaker is depressed. Check for 115 Vac across point C and terminal 5.

If voltage is not present, heater circuit breaker is defective. Replace heater circuit breaker.

STEP 4. Turn MOTOR switch ON, check for 115 Vac across points D and E.

If voltage is not present, motor switch is defective. Replace motor switch (para. 3-193).

STEP 5. Check for 115 Vdc across terminals 3 and 4.

If voltage is not present, rectifier is defective. Replace rectifier (para. 3-193).

Table 3-2. Troubleshooting-CONT

MALFUNCTION	TEST OR INSPECTION	CORRECTIVE ACTION
-------------	--------------------	-------------------

ROTARY WINDOW - CONT

- STEP 6. Check for 115 Vdc across pins D and E on screen power connector on junction box.  
If voltage is not present, power cable from control box to screen is defective. Replace power cable (para. 3-193).
- STEP 7. Turn HEATER switch ON, check for 115 Vac across terminals 5 and 6.  
If voltage is not present, heater switch is defective. Replace heater switch (para. 3-193).
- STEP 8. Check for 115 Vac across pins B and C on screen power connector on junction box.  
If voltage is not present, power cable from control box to screen is defective. Replace power cable (para. 3-193).

PROPELLER SHAFT ASSEMBLY  
EXPANDER TUBE BRAKE

59. Shaft brake will not engage.

- STEP 1. Check for lack of air supply to quick release exhaust valve on brake.  
Check control 125 psi air pressure to shaft brake. Refer to TM 55-1905-223-10.
- STEP 2. Check condition of quick release exhaust valve.  
Replace quick release exhaust valve. Refer to paragraph 3-204.
- STEP 3. Inspect rubber actuating tube for cracks, cuts or swelling.  
Replace tube if cracked, cut or swollen. Refer to paragraph 3-204.
- STEP 4. Defective brake panel.  
Refer to brake panel troubleshooting (Table 2-2).

60. Shaft brake will not disengage.

- STEP 1. Check quick release exhaust valve for damage.  
Replace quick release exhaust valve. Refer to paragraph 3-204.

61. Shaft brake drags (will not disengage fully).

- STEP 1. Check to see if friction shoes do not retract fully.  
Replace contaminated quick release exhaust valve. Refer to paragraph 3-204.
- STEP 2. Inspect flat release springs for broken ones.  
Replace broken flat release springs.

Table 3-2. Troubleshooting - CONT

MALFUNCTION	TEST OR INSPECTION	CORRECTIVE ACTION
-------------	--------------------	-------------------

**PROPELLER SHAFT ASSEMBLY**  
**EXPANDER TUBE BRAKE - CONT**

STEP 3. Inspect friction shoes for build up of contamination on lining.  
 Clean friction shoe linings. Refer to paragraph 3-204 .

STEP 4. Inspect rubber actuator tube for hardening or swollen spots.  
 Replace rubber actuator tube. Refer to paragraph 3-204 .

62. Shaft brake slips when locked.

STEP 1. Check for oil or grease on friction shoes.  
 Replace friction shoes. Refer to paragraph 3-204 .

**POTABLE WATER PIPING SYSTEM**

63. Low discharge pressure.

STEP 1. Check for leaking pipes and fitting.  
 Reseal or replace pipes and welded fittings (para. 3-83).

STEP 2. Check for defective pressure tank.  
 a. Inspect for leaks at weld joints, excessive corrosion, security, and general condition of tank.  
 b. Replace or repair tank as necessary (para. 3-83).

STEP 3. Check or defective pump.  
 a. Excessive impeller running clearance.

**CAUTION**

Do not allow pump to operate with insufficient impeller clearance.

- (1) Adjust impeller clearance (para. 3-109).
- (2) If adjustment does not restore desired performance. Replace the impeller and raceway as necessary (para. 3-109).

**NOTE**

The impeller and raceway are matching parts and must be replaced as a set.

- b. Excessive vibration.
  - (1) Bent shaft or badly worn bearings. Repair pump (para. 3-109).

Table 3-2. Troubleshooting - CONT

MALFUNCTION	TEST OR INSPECTION	CORRECTIVE ACTION
-------------	--------------------	-------------------

**POTABLE WATER PIPING SYSTEM - CONT**

- c. Leaking seal.
  - (1) Improper assembly. Repair pump (para. 3-109).
  - (2) Worn seal faces. Repair pump (para. 3-109).

64. No discharge pressure.

- STEP 1. Check for defective pump.  
Refer to Malfunction 1, Step 3.

65. Storage tank bulging.

- STEP 1. Fill rate too high (exceeds 80 psi).  
Replace pressure switch, (para. 2-322).
- STEP 2. Inspect tank vent valve.
  - a. Ensure that flame screens, ball checks, and lines are free of rust and debris.
  - b. Replace or repair vent valve (para. 3-209).

66. Hot water heater.

- STEP 1. No hot water.
  - a. Check thermostatic switches with ohmmeter for open or grounded circuit.

**NOTE**

Switch circuits are normally closed, and opened on temperature rise.

- b. Replace or repair thermostatic switches (para. 3-213).
- STEP 2. Water temperature below thermostat set point.  
Check thermostatic switch. Replace switch (para. 3-219).
- STEP 3. Water temperature exceeds 210°F.  
Check thermostatic switch. Replace switch (para. 3-219).
- STEP 4. Water pressure exceeds 110 psi.  
Replace relief valve (para 3-209).



**SECTION V. INTERMEDIATE DIRECT SUPPORT MAINTENANCE PROCEDURES**

3-10. Detailed Procedures. Information to perform intermediate direct support maintenance tasks, in accordance with the Maintenance Allocation Charts (MACs), is provided. The procedures for each separate MAC begin with a boxed heading showing:

MAINTENANCE OF...

<b>MAINTENANCE OF HALON FIREFIGHTING SYSTEM</b>
---

---

### 3-11. Service Halon Subsystem, Paint Locker and Main Machinery Room; Carbon Dioxide Cylinders. (Figure 3-1)

---

**This task covers: a. Service**

---

#### **INITIAL SETUP:**

##### Tools

Tool kit, general mechanic's,  
5180-00-69.9-5273  
Lifting yoke P/N 42432  
Weight scale P/N 53711

##### Equipment Condition

Pull boxes tagged "Out of Service - Do  
Not Operate."  
Refer to cylinder for correct weight.

##### Materials/Parts

Warning tags, Item 1, Appendix C

---

#### **SERVICE**

##### a. Paint Locker.

- (1) Install pin (7) in release lever (4).
- (2) Disconnect cable (5) from cable mount (6) on release lever.
- (3) Unscrew and remove release lever from cylinder valve (3).
- (4) Disconnect discharge hose (1) from cylinder valve at hose connector (2).
- (5) Install lifting yoke (8) at bottom of cylinder valve (3).
- (6) Remove four hex plain nuts (13), lockwashers (12), and hexhead capscrews (11) securing cylinder tank (9) and straps (10).
- (7) Remove cylinder straps from cylinder channels (14).

#### **NOTE**

Use an overhead support bracket or rail to weigh carbon dioxide cylinder.

- (8) Attach weigh scale assembly (16, 17) and lifting yoke (8) to overhead support bracket or rail (15).

**Change 1 3-44**

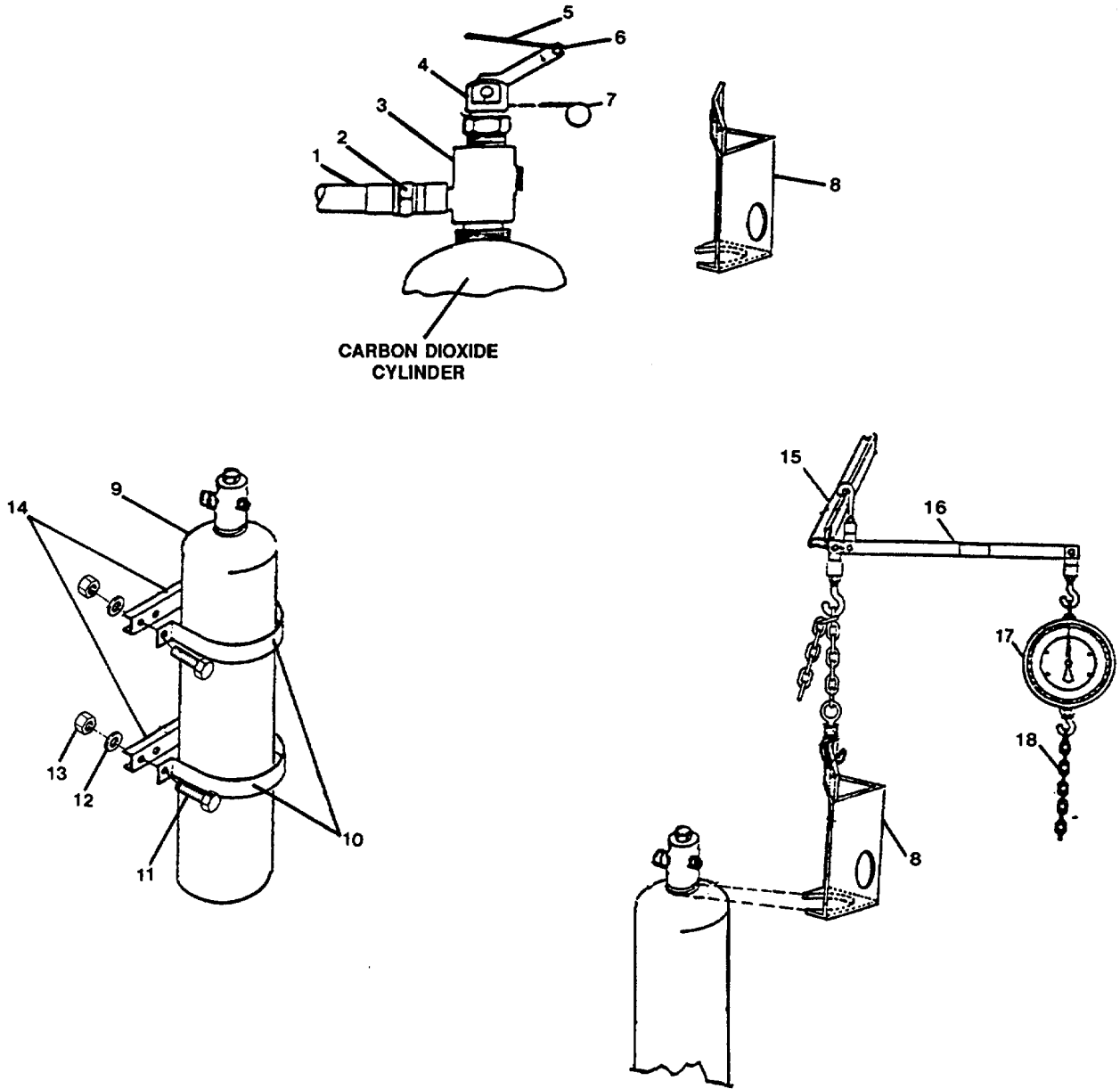

FIGURE 3-1. Carbon Dioxide Cylinders (Paint Locker and Main Machinery Room).

- (9) Lift cylinder by pulling down on chain link (18) connected to bottom of scale.
- (10) When lever arm (16) on scale assembly is in horizontal position, read weight from scale.
- (11) Lower cylinder to deck.

**WARNING**

If cylinder weight loss exceeds 10% of change as specified on name plate, cylinder is not adequate for use and must be replaced.

- (12) Remove lifting yoke (8) from cylinder valve.
- (13) Remove weight scale assembly (16, 17) and lifting yoke (8) from overhead support bracket or rail (15).
- (14) Position cylinder with cylinder channels (14) and aligned with mounting screw holes.
- (15) Position cylinder straps (10) over cylinder (9).
- (16) Secure cylinder straps with four hexhead capscrews (11), lockwashers (12) and hex plain nuts (13).
- (17) Connect discharge hose (1) to cylinder valve at hose connector (2).
- (18) Install release lever (4) on cylinder valve (3).
- (19) Connect cable (5) to cable mount (6) on release lever.
- (20) Remove pin (7) from release lever.
- (21) Remove tag from pull box.

b. Main Machinery Room.

**NOTE**

Carbon dioxide cylinder servicing procedures are the same for the paint locker and the main machinery room.

Refer to steps a.(1) through a.(21) above.

---

**3-12. Service Halon Subsystem, Paint Locker and Main Machinery Room; Halon Tanks .**

---

**This task covers:    Service**

---

**INITIAL SETUP:****Tools**

Tool kit, general mechanic's,  
5180-00-699-5273  
Lifting yoke, 1" P/N 52829

**Equipment Condition**

Pull boxes tagged "Out of Service -  
Do Not Operate."  
Refer to tank nameplate for proper  
weight.

**Materials/Parts**

Warning tags, Item 1, Appendix C

---

**SERVICE****a. Paint Locker.**

- (1) Disconnect hose connector (2, Figure 3-2) from male adapter elbow (1) on actuator (4).
- (2) Remove male adapter elbow from actuator.
- (3) Remove actuator from halon tank valve (6).
- (4) Install protective shipping cap (5) on actuator mounting threads.
- (5) Disconnect discharge hose (8) from tank valve (6) at union elbow (7).
- (6) Remove two hex plain nuts (18), lockwashers (17) and hex head capscrews (16) securing halon tank (9) and halon brackets halves (15) and (19).
- (7) Loosen two hex head capscrews (13) and slide capscrews and channel units (11, 12) off cylinder channels (10).
- (8) Slide halon bracket halves (15) clear of halon tank and off cylinder channels.
- (9) Slide halon bracket halves (19) on cylinder channels away from and clear of halon tank.
- (10) Remove halon tank from platform (14).
- (11) Position lifting yoke (26) over valve (6) on halon tank.

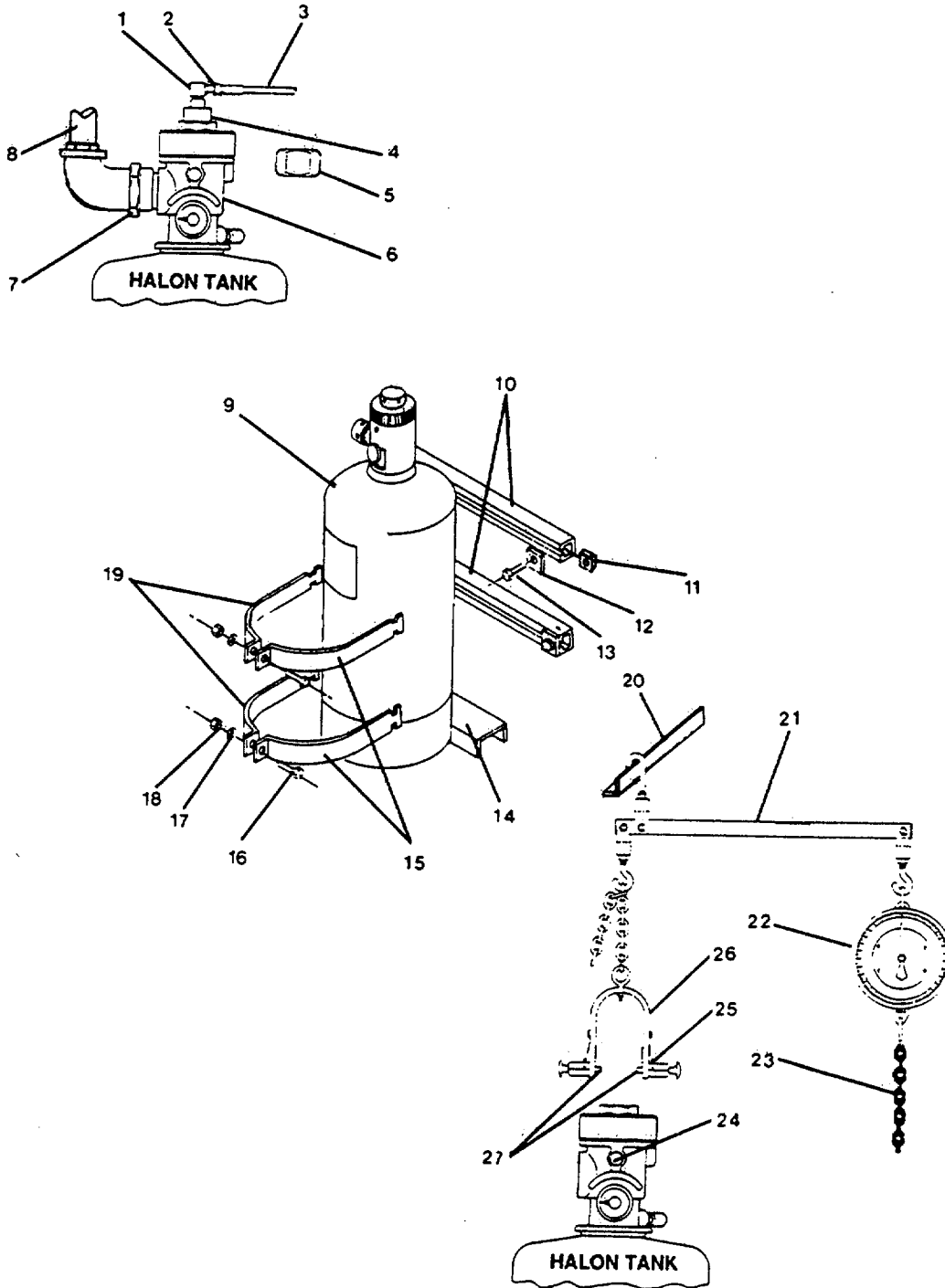

FIGURE 3-2. *Halon Tanks (Paint Locker).*

- (12) Align and engage lifting pins (27) into lifting ports (24).
- (13) Install safety pins (25) to secure lifting pins.

**NOTE**

Use an overhead support bracket or rail to weigh halon tank.

- (14) Attach weigh scale assembly (21, 22) and lifting yoke (26) to overhead support bracket or rail (29).
- (15) Lift halon tank by pulling down on chain link (23) connected to bottom of scale.
- (16) When lever arm (21) on scale assembly is in horizontal position, read weight from scale.
- (17) Lower tank to deck.

**WARNING**

If cylinder weight does not meet the specifications on the cylinder name plate, it is not adequate for use and must be replaced.

- (18) Release safety pins (25) from lifting pins (27).
- (19) Disengage lifting pins from lifting ports (24) on tank valve.
- (20) Remove lifting yoke (26) from tank valve.
- (21) Remove weigh scale assembly (21, 22) and lifting yoke from overhead support bracket or rail.
- (22) Position halon tank (9) on platform (14).
- (23) Position halon bracket halves (19) over tank.
- (24) Install halon bracket halves (15) on cylinder channels (10) and over tank.
- (25) Secure halon brackets (15, 19) with two hex head capscrews (16), lockwashers (17) and hex plain nuts (18).
- (26) Install two hex head capscrews (13) with channel nuts (11, 12) on cylinder channels.
- (27) Remove protective shipping cap (5) from actuator threaded mount.
- (28) Connect discharge hose (8) to tank valve (6) at union elbow (7).
- (29) Install actuator (4) on halon tank valve.

- (30) Install male adapter elbow (1) on actuator.
- (31) Connect hose (3) at male adapter elbow with hose connector (2).
- (32) Remove tag from pull box.

b. Main Machinery Room.

- (1) Disconnect hose connector (2, Figure 3-3) at male adapter tee (3) to remove hoses (1).
- (2) Remove male adapter tee from actuator (4).
- (3) Repeat steps (1) and (2) for other halon tank in subsystem.

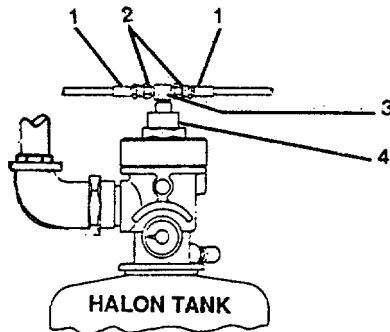

FIGURE 3-3. Main Machinery Room Halon Tank Service.

**NOTE**

Halon tank servicing procedures are for the same paint locker and the main machinery room.

- (4) Refer to steps a.(3) through a.(29) above.
- (5) Install male adapter tee (3) on actuator.
- (6) Connect hoses (1) at male adapter tee with hose connectors (2).
- (7) Repeat steps (5) and (6) for other halon tank in subsystem.
- (8) Remove tag from pull box.



**3-13. Replace/Repair Halon Subsystem (Paint Locker, Main Machinery Room).**

**This task covers:**

**a. Removal**

**b. Repair**

**c. Replacement**

**INITIAL SETUP :**

Tools

Tool kit, general mechanic's,  
5180-00-699-5273  
Tool kit, electrician's,  
5180-00-392-2895

Equipment Condition

Tag each pull box "Out of Service -  
Do Not Operate" before beginning  
maintenance on halon system.  
Notify the Bridge that the halon system  
will be secure for an indefinite  
period of time for maintenance.

Materials/Parts

Release lever P/N 42486  
Nonmetallic assembly (CO2) P/N 42424  
Globe valve (1/2 in.) P/N 41451  
Pressure operated switch P/N 46250  
Time delay (60 sec. right hand)  
P/N 41732  
Nonmetallic hose assembly (1/4 in.)  
P/N 32336  
Electro-pneumatic actuator P/N 32096  
Halon nozzle P/N 32659  
Fire hose foam nozzle (2 in.) P/N 32663  
Warning tags, Item 1, Appendix C

**REMOVAL**

a. Remove Carbon Dioxide Cylinder.

(1) Release lever.

(a) Install pin (21, Figure 3-4) in release lever (26).

(b) Disconnect cable (29) from cable mount (30) on release lever.

(c) Unscrew and remove release lever (26) from cylinder valve (25) on carbon dioxide cylinder.

(2) Hose assembly.

(a) Disconnect discharge hose connector (23) from cylinder valve (25).

(b) Disconnect hose connector (28) on opposite end of discharge hose (24) from pipe fitting (27).

(c) Remove hose assembly.

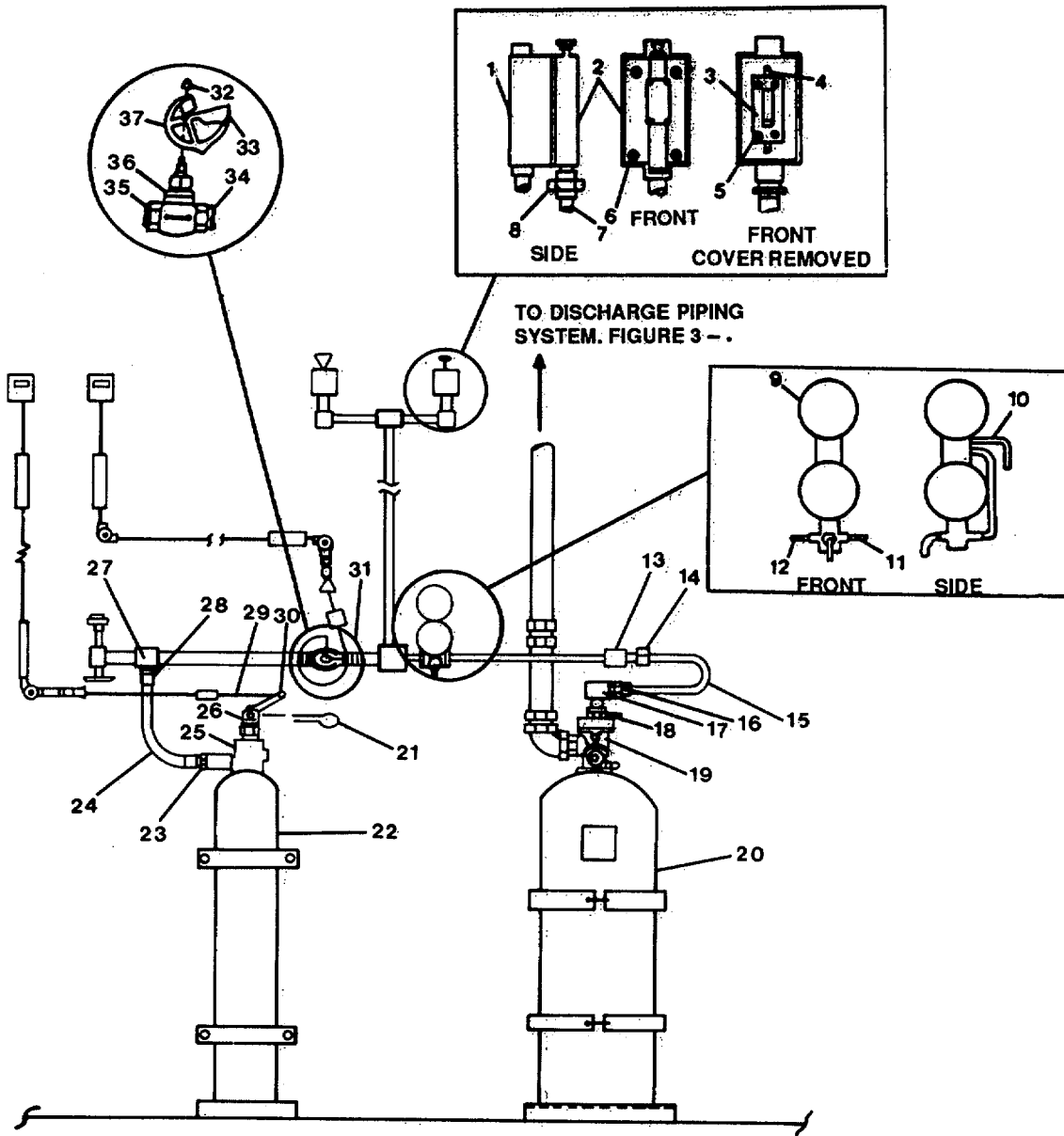

FIGURE 3-4. Halon Subsystem - Paint Locker/Main Machinery Room.

b. Remove Halon Tank.

(1) Hose Assembly.

- (a) Disconnect hose connector (16).
- (b) Disconnect hose connector (14) on opposite end of hose (15) from pipe fitting (13).
- (c) Remove hose assembly.

(2) Electro-pneumatic actuator.

- (a) Remove male adapter (17) from actuator (18).
- (b) Unscrew and remove actuator (18) from valve (19) on halon tank (20).

(3) Halon nozzles.

- (a) Position pipe wrench over halon nozzle (1, Figure 3-5) with counter-clockwise rotation to remove nozzle from metallic pipe (2) in halon piping system.
- (b) Repeat step for remaining nozzle.

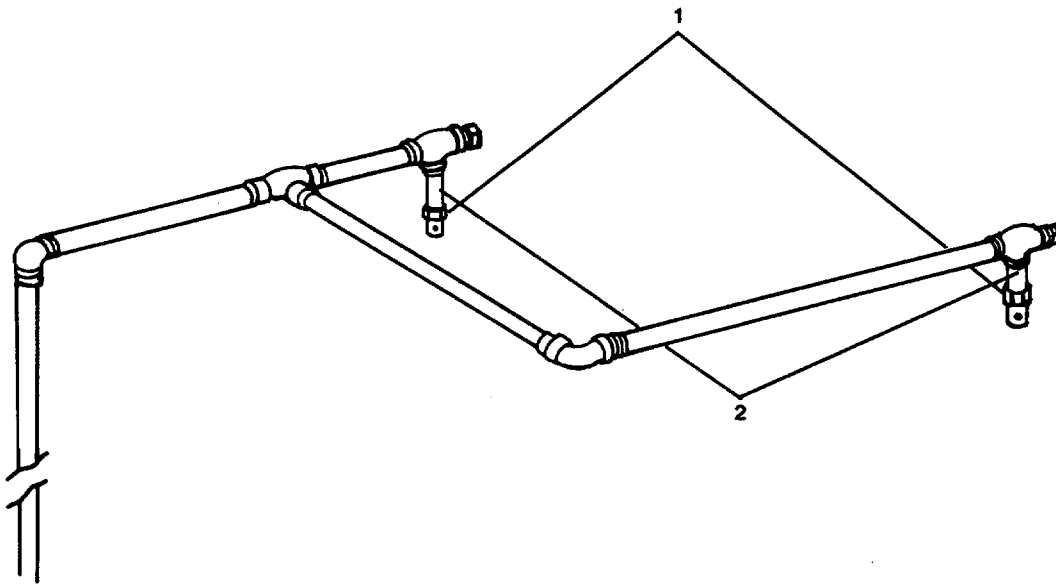

FIGURE 3-5. *Halon Nozzles.*

(4) Fire foam nozzles.

- (a) Position pipe wrench over union (2, Figure 3-6); turn with counterclockwise rotation to remove fire foam nozzle (3) from metallic pipe (1).
- (b) Repeat steps for remaining nozzles.

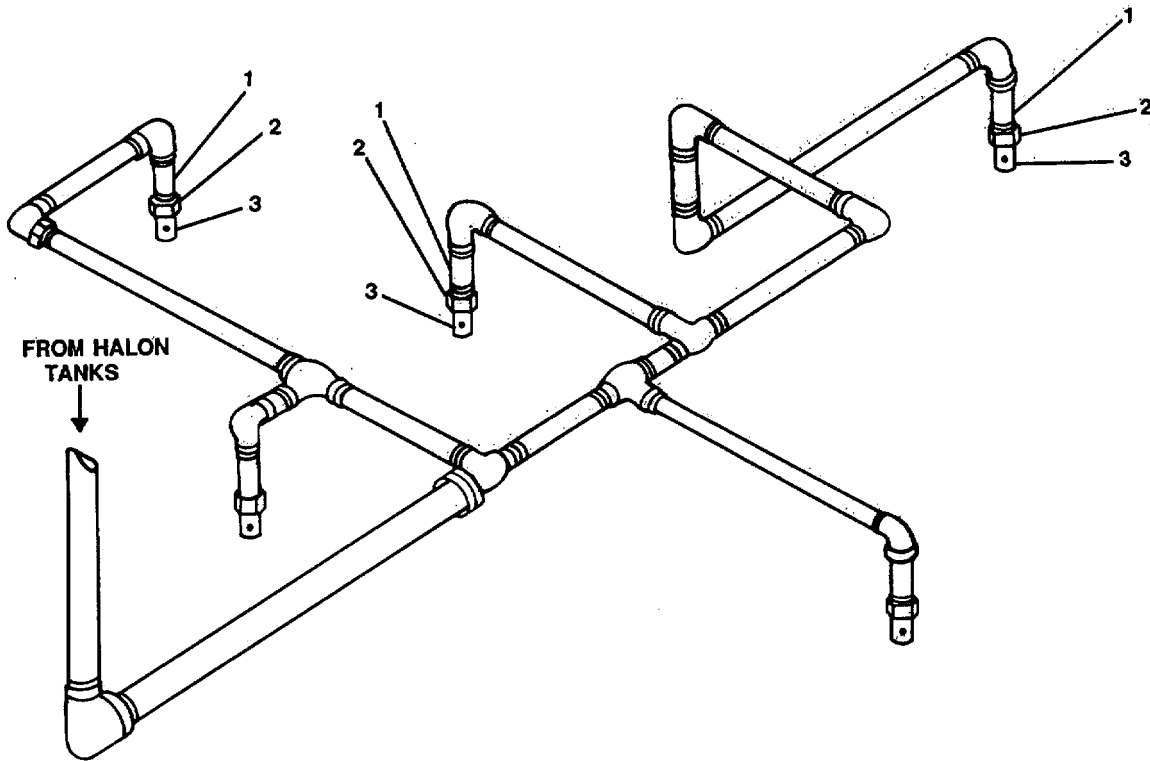

FIGURE 3-6. Fire Foam Nozzles.

c. Remove Globe Valve.

- (1) Disconnect cable (3, Figure 3-4) from cable mount (33) on sector handle (37).
- (2) Remove nut (32) and remove sector handle from valve (36).
- (3) Disconnect piping (34, 35) from valve.
- (4) Remove valve.

d. Remove Time Delay (60 Seconds).

- (1) Disconnect piping (11, 12) from time delay (9).
- (2) Remove mounting hardware from bracket (10).
- (3) Remove time delay.

e. Remove Pressure Operated Switch.

**WARNING**

Be sure that electrical power to pressure operated switch is turned OFF and tagged "Out of Service - Do Not Operate" before proceeding with removal procedures.

- (1) Disconnect pipe (7) from cylinder at union (8).
- (2) Remove four screws (6) securing cover assembly (2) to housing (1).
- (3) Remove cover assembly.
- (4) Remove four screws (5) securing electrical wire leads to switch (3).
- (5) Tag and separate wiring from switch.
- (6) Remove two screws (4) securing switch in housing body.
- (7) Remove switch.

**REPAIR**

Repair of the halon subsystem consists of replacing globe valve (36), time delay (9), pressure operated switch (3), nonmetallic hose assemblies (15, 24), release lever (26), electro-pneumatic actuator (18), halon nozzle (1, Figure 3-5), and fire foam nozzles (3, Figure 3-6).

**REPLACEMENT****a. Replace Pressure Operated Switch.**

- (1) Position switch (3, Figure 3-4) in housing body (1) with mounting screw holes aligned.
- (2) Secure switch with two screws (4).
- (3) Position electrical wire leads on switch.
- (4) Secure wire leads to switch with four screws (5).
- (5) Remove tags from wiring.
- (6) Position cover assembly (2) on housing with switch and mounting screw holes aligned.
- (7) Secure cover assembly with four screws (6).
- (8) Connect pipe (7) to cylinder at union (8).

**b. Replace Time Delay (60 Seconds).**

- (1) Position time delay (9) and install mounting hardware on bracket (10).

(2) Connect piping (11, 12) to time delay (9).

c. Replace Globe Valve.

(1) Position valve (36) and connect piping (34, 35).

(2) Install sector handle (37) and secure with nut (32).

(3) Connect cable (31) to cable mount (33) on sector handle (37).

d. Replace Halon Tank.

(1) Fire foam nozzles.

(a) Install fire foam nozzle (3, Figure 3-6) on threaded end of metallic pipe (1).

(b) Secure with union (2).

(c) Repeat steps for remaining nozzles.

(2) Halon nozzles.

(a) Install halon nozzle (1, Figure 3-5) on threaded end of metallic pipe (2).

(b) Position pipe wrench over nozzle with clockwise rotation to secure nozzle to metallic pipe in halon system.

(c) Repeat steps for remaining halon nozzle.

(3) Electro-pneumatic actuator.

(a) Install actuator (18) in valve (19, Figure 3-4) on halon tank (20).

(b) Install male adapter (17) on actuator.

(4) Hose assembly.

(a) Position hose assembly over halon tank.

(b) Connect hose connector (14) on opposite end of hose (15) to pipe fitting (13).

(c) Connect hose connector (16) to male adapter on halon tank.

e. Replace Carbon Dioxide Cylinder.

(1) Hose assembly.

(a) Position hose assembly over cylinder.

(b) Connect hose connector (28) on opposite end of discharge hose (24) to pipe fitting (27).

- (c) Connect discharge hose connector (23) to cylinder valve (25).
- (2) Release lever.
- (a) Install release lever (26) on cylinder valve (25).
  - (b) Connect cable (29) to cable mount (30) on release lever.
  - (c) Remove pin (21) from release lever (26).
  - (d) Remove tags from pull boxes.

<b>MAINTENANCE OF PURIFIER/SEPARATORS</b>
---

---

### 3-14. Replace/Repair Lube Oil Purifier. (Figure 3-7)

---

**This task covers:**

a. Removal

b. Replacement

**INITIAL SETUP:**Tools

Tool kit, general mechanic's,  
5180-00-699-5273  
Tool kit, electrician's,  
5180-00-391-1087

Equipment Condition

Electric power to lube oil purifier  
turned OFF at P205 power/lighting  
panel and tagged "Out of Service  
Do Not Operate."

Materials/Parts

Purifier P/N DTB2-00-066  
Gasket P/N 0004-5445-74(4)  
Warning tags, Item 1, Appendix C

---

**REMOVAL**

- a. Remove terminal box cover (1).
- b. Tag and disconnect electrical wiring at terminal box.
- c. Remove mounting screws and gasket (2) to disconnect purifier from piping systems.
- d. Remove purifier mounting bolts (3) and remove purifier.

**REPLACEMENT**

- a. Position purifier and install mounting bolts (3).
- b. Using a new gasket at each connection point, connect purifier to piping systems with mounting screws (2).
- c. Install electrical wiring at terminal box.
- d. Install terminal box cover (1).
- e. Remove tag and turn on electrical power at P205 power/lighting panel.



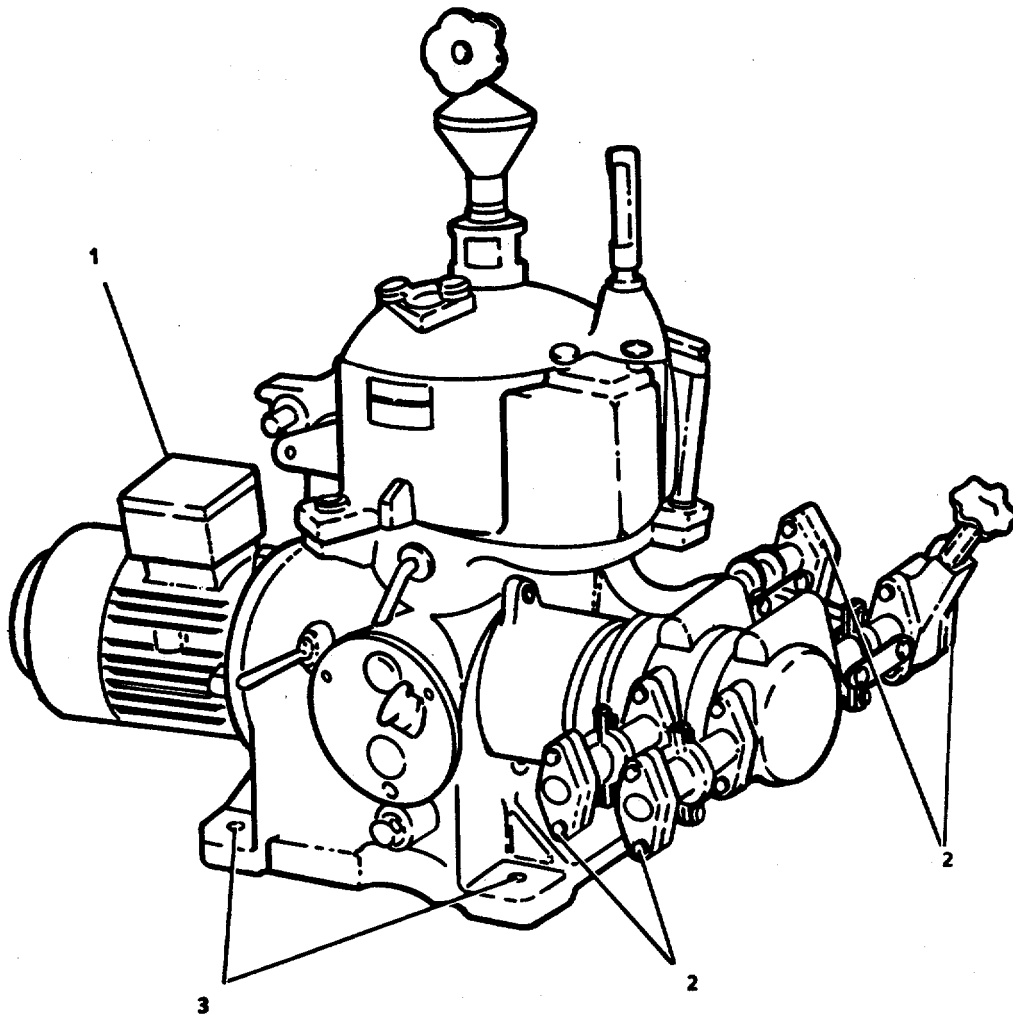

FIGURE 3-7. Lube Oil Purifier.

---

**3-15. Repair Double Gear Pump Assembly. (Figure 3-8)**

---

**This task covers:****a. Disassembly****b. Repair****c. Assembly**

---

**INITIAL SETUP:**Tools

Tool kit, general mechanic's,  
5180-00-699-5273

Equipment Condition

Double gear pump assembly removed as  
specified in paragraph 2-19 .

Materials/Parts

Threaded pin P/N 0019-3973-060  
Sleeve P/N 2125-1074-000  
Driver P/N 2125-3438-000  
Retaining ring P/N 354  
Gasket P/N 8054-9125-010  
Shaft and gear set P/N 8054-9415-070  
Gasket P/N 0007-1792-550  
Gasket P/N 376  
Relief valve spindle P/N 375  
Cylindrical spring P/N 374  
Relief valve piston P/N 373

---

**DISASSEMBLY**

- a. Slide sleeve (2) off shaft and gear set (22).
- b. Remove threaded pin (1).
- c. Remove driver (3) from slotted end of shaft and gear set.
- d. Remove retaining ring (4) and sealing ring (5).
- e. Remove four machine screws (20) and separate both gear housings (21 and 24) from driver cover (6).
- f. Separate both gear housings.
- g. Remove gaskets (23) and (25).
- h. Remove shaft and gear set (22).
- i. Remove six machine screws (8) securing relief valve housing (18) to gear housing (21).

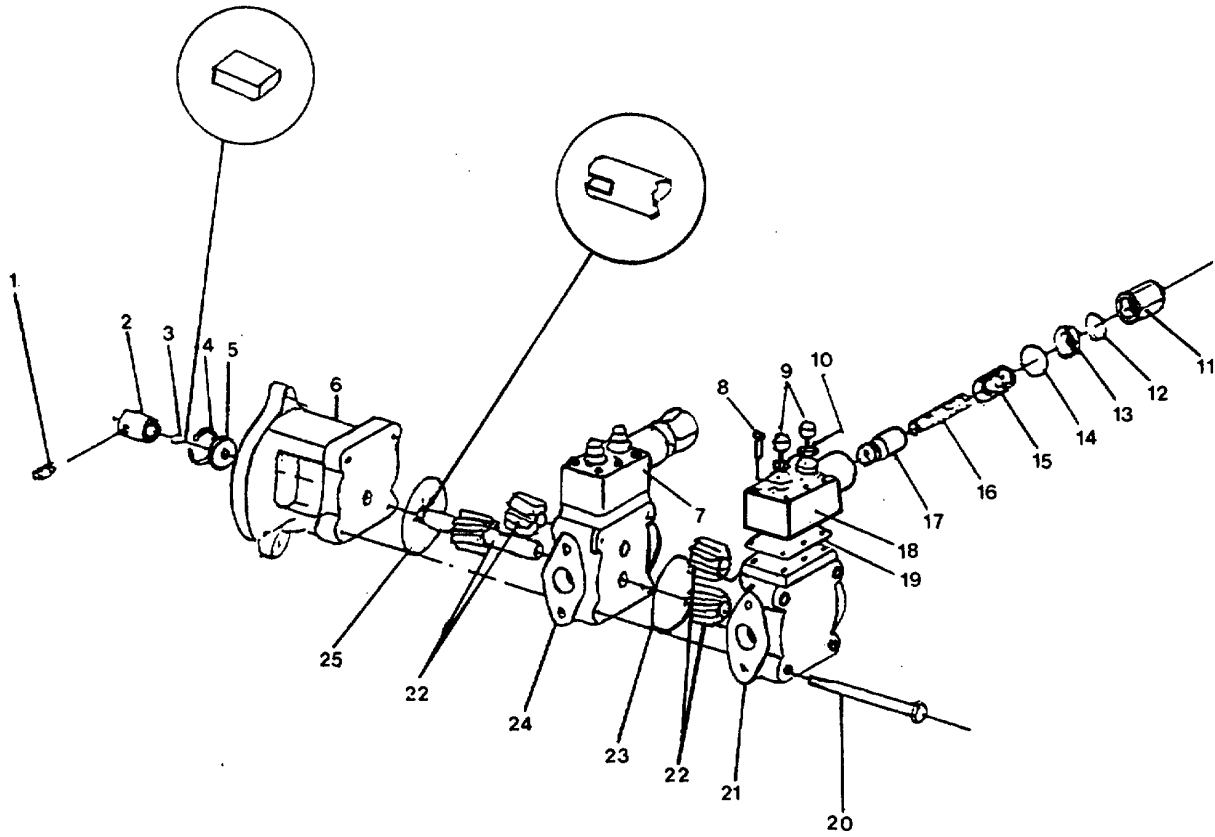

FIGURE 3-8. Double Gear Pump Assembly.

- j. Remove relief valve housing.
- k. Remove gasket (19).
- l. Remove two screw plugs (9) on relief valve housing.
- m. Remove gaskets (10).
- n. Remove cap nut (11) and gasket (12) from side of relief valve housing.
- o. Remove lock nut (13).
- p. Remove gasket (14), relief valve spindle (15), cylindrical spring (16) and relief valve piston (17).
- q. Repeat steps i. through p. above to disassemble relief valve housing (7).

## REPAIR

Repair of double gear pump assembly consists of replacing threaded pin (1), sleeve (2), driver (3), retaining ring (4), gaskets (23, 25), shaft and gear set (22), gaskets (19), gaskets (10), gaskets (12), gaskets (14) relief valve spindle (15), cylindrical spring (16), and relief valve piston (17).

## ASSEMBLY

- a. Install relief valve piston (17), cylindrical spring (16) relief valve spindle (15) and gasket (14) on side of relief valve housing (18).
- b. Install lock nut (13).
- c. Install gasket (12) and cap nut (11) on relief valve housing.
- d. Position gaskets (10) on relief valve housing.
- e. Install two screw plugs (9) through gaskets (10) and secure to relief valve housing.
- f. Position gasket (19) on gear housing (21).
- g. Position relief valve housing over gear housing with mounting screw holes aligned.
- h. Install six machine screws (8) and secure relief valve housing to gear housing.
- i. Repeat steps a. through h. above to assemble relief valve housing (7).
- j. Install gaskets (23) and (25) on gear housing (21) and (24).
- k. Install shaft and gear set (22).
- l. Assemble gear housing by engaging both gear housings on shaft and gear set with mounting screw holes aligned with driver cover (6).

- m. Install four machine screws (20) and secure gear housings to driver cover.
- n. Install sealing ring (5) and retaining ring (4).
- o. Install driver (3) on slotted end of shaft and gear set.
- p. Install threaded pin (1) on sleeve (2).
- q. Slide sleeve (2) on shaft and gear set.
- r. Double gear pump assembly replaced as specified in paragraph 2-16 .

---

**3-16. Replace Bowl Assembly. (Figure 3-9)**

---

**This task covers:****a. Removal****b. Replacement**

---

**INITIAL SETUP:**Tools

Tool kit, general mechanic's  
5180-00-699-5273

Annular wrench

P/N 0003-3997-000(80871)

Hook wrench

P/N 0003-3667-000(80871)

Equipment Condition

Hood assembly removed as specified in  
paragraph 2-20 .

Materials/Parts

Bowl assembly P/N 2125-6600-L

---

**REMOVAL**

- a. Release brake by turning handle (1) clockwise until bowl assembly can be rotated by hand.
- b. Turn two bowl lock screws (2) clockwise until they fit into recesses in bowl bottom (17). (One recess is located below "O" mark of bowl bottom.) Do not apply pressure to lock screws. It may be necessary to rotate bowl assembly by hand to align recesses with lock screws.

<b>CAUTION</b>
----------------

Both lock ring (6) and (7) are left hand thread.

- c. Unscrew lock ring (6) by tapping on handle of hook wrench in clockwise direction (left hand thread).
- d. Remove lock ring, regulating ring (5) and gasket (4) from bowl top (8).
- e. Unscrew lock ring (7) by tapping on handle of annular wrench in clockwise direction (left hand thread).
- f. Remove lock ring, bowl top (8), preformed packing (9), compensating disc (10), disc stack (11) and distributor (12) from bowl bottom (17).

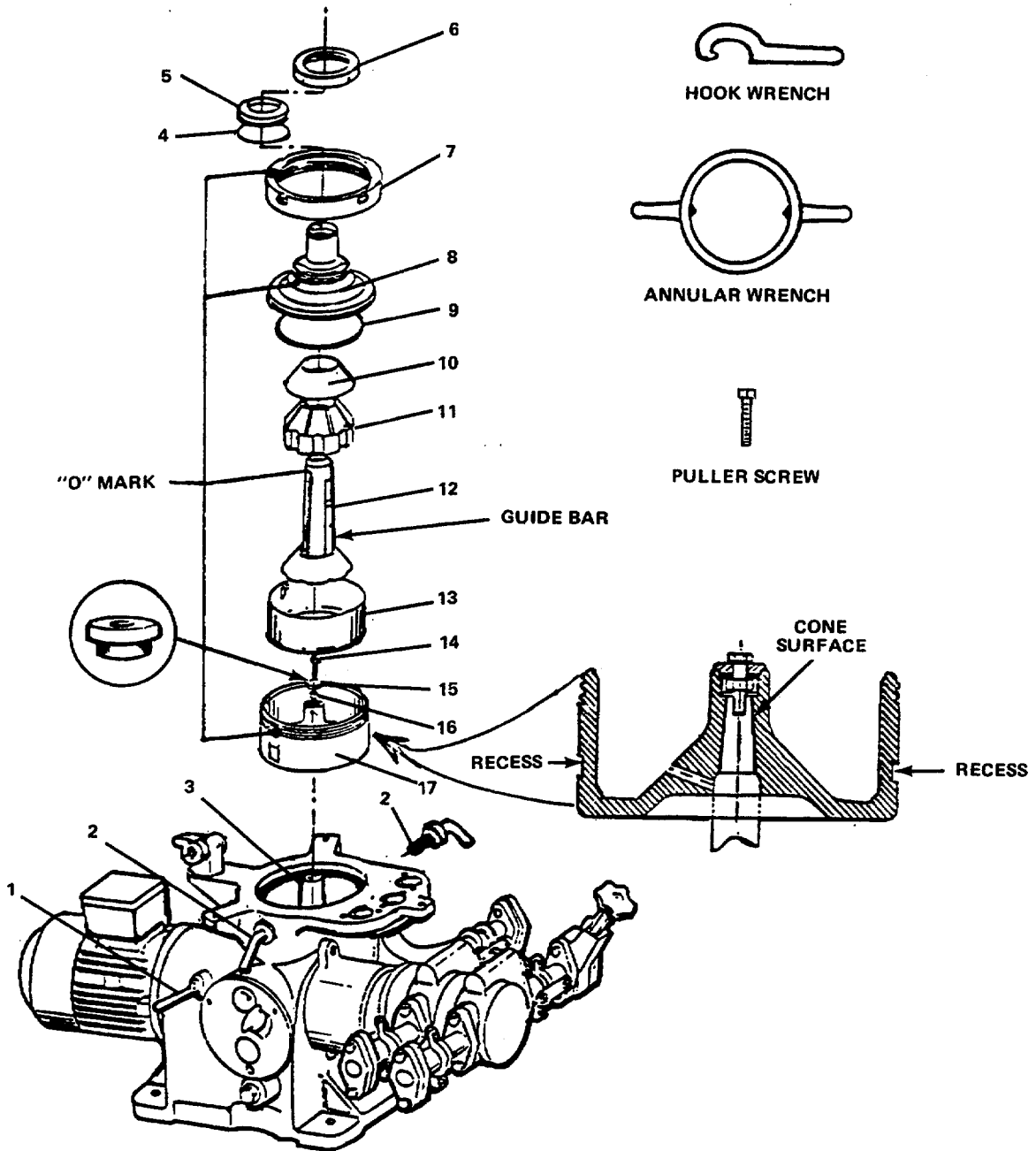

FIGURE 3-9. Bowl Bottom Assembly.  
3-65

- g. Remove sludge liner (13).
- h. Turn machine screw (14) in counterclockwise direction and off spindle (3) (right hand thread).
- i. Set brake by turning handle (1) counterclockwise.
- j. Loosen bowl lock screws (2) until screws are clear of recesses in bowl bottom.
- k. Install puller screw in spindle screw hole and turn in clockwise direction to force bowl bottom off cone surface of spindle (3).
- 1. Remove puller screw and bowl bottom.
- m. Remove centering disc (15) and hex plain nut (16) from bowl bottom.

## REPLACEMENT

- a. Lubricate bowl lock rings (6, 7) and threads of bowl top (8) and bowl bottom (17). Refer to LO 55-1905-223-12 .
- b. Set brake by turning handle (1) counterclockwise.
- c. Install puller screw on centering disc (15), hex plain nut (16) and bowl bottom (17).
- d. Position bowl bottom onto cone surface of spindle (3).
- e. Remove puller screw.
- f. Release brake by turning handle (1) clockwise until bowl bottom can be turned by hand.
- g. Turn lock screws (2) clockwise until they fit into recesses in bowl bottom (17). (One recess is located below "O" mark on bowl bottom.) Do not apply pressure to lock screws. It may be necessary to rotate bowl by hand to align recesses with lock screws.
- h. Install and turn machine screw (14) in clockwise direction to secure bowl bottom to spindle (right hand thread).
- i. Install distributor (12) into bowl bottom. "O" mark on distributor must be aligned with "O" mark on bowl bottom.
- j. Install disc stack (11) and compensating disc (10) on distributor.
- k. Install sludge liner (13) in bowl bottom.
- 1. Install preformed packing (9) on bowl bottom.
- m. Install bowl top (8) on distributor with "O" marks aligned and guide bars of the distributor catches into the grooves of bowl top.



**CAUTION**

Both lock rings (7 and 6) are left hand thread.

- n. Install lock ring (7) on threads of bowl bottom by hand in counterclockwise direction then tighten it with annular wrench (left hand thread). Tap against the wrench handle until the "O" marks on lock ring and bowl top (8) are aligned. Do not slip a pipe over wrench handle to obtain leverage.
- o. Install gasket (4) and regulating ring (5) on bowl top.
- p. Install lock ring (6) on threads of bowl top by hand in counterclockwise direction then tighten it with hook wrench (left hand thread). Tap against the wrench handle until a slight resistance is felt. Do not over tighten lock ring.
- q. Loosen bowl lock screws (2) until bowl assembly can be turned by hand.
- r. Set brake by turning handle (1) counterclockwise.
- s. Replace hood assembly as specified in paragraph 2-20 .

### 3-17. Replace Vertical Gear Assembly

This task covers:

a. Removal

b. Replacement

#### INITIAL SETUP:

##### Tools

Tool kit, general mechanic's,  
5180-00-699-5273  
Gear puller P/N 3375016  
Arbor press P/N 4920-00-373-9376

##### Equipment Condition

Bowl assembly removed as specified  
in paragraph 3-16 .  
Pump connection assembly removed as  
specified in paragraph 2-18 .  
Double gear pump assembly removed as  
specified in paragraph 2-19 .

##### Materials/Parts

Vertical Gear Assembly P/N  
2125-4003-000  
Lubricating oil  
Preformed packing

#### REMOVAL

- a. Remove oil drain screw (9, 11, Figure 3-10) and drain oil.
- b. Remove three machine screws (13) from housing (2) and remove revolution indicator housing (12).
- c. Set brake by turning handle (1) counterclockwise.
- d. Loosen three hexhead screws (9) on worm wheel (10) enough to slide worm wheel to the right and clear off worm spindle.

#### NOTE

Two soldiers are required.

- e. Remove four hex plain nuts (3) and cup springs (4) from mounting studs (8).
- f. Lift frame off of caps (5), rubber cushions (6), caps (7), and mounting studs. Position frame assembly with bottom exposed.

#### NOTE

Refer to Figure 3-11 for the remaining removal procedures.

- g. Remove three machine screws (13) and lockwashers (14) from bearing cover (15) on bottom frame.

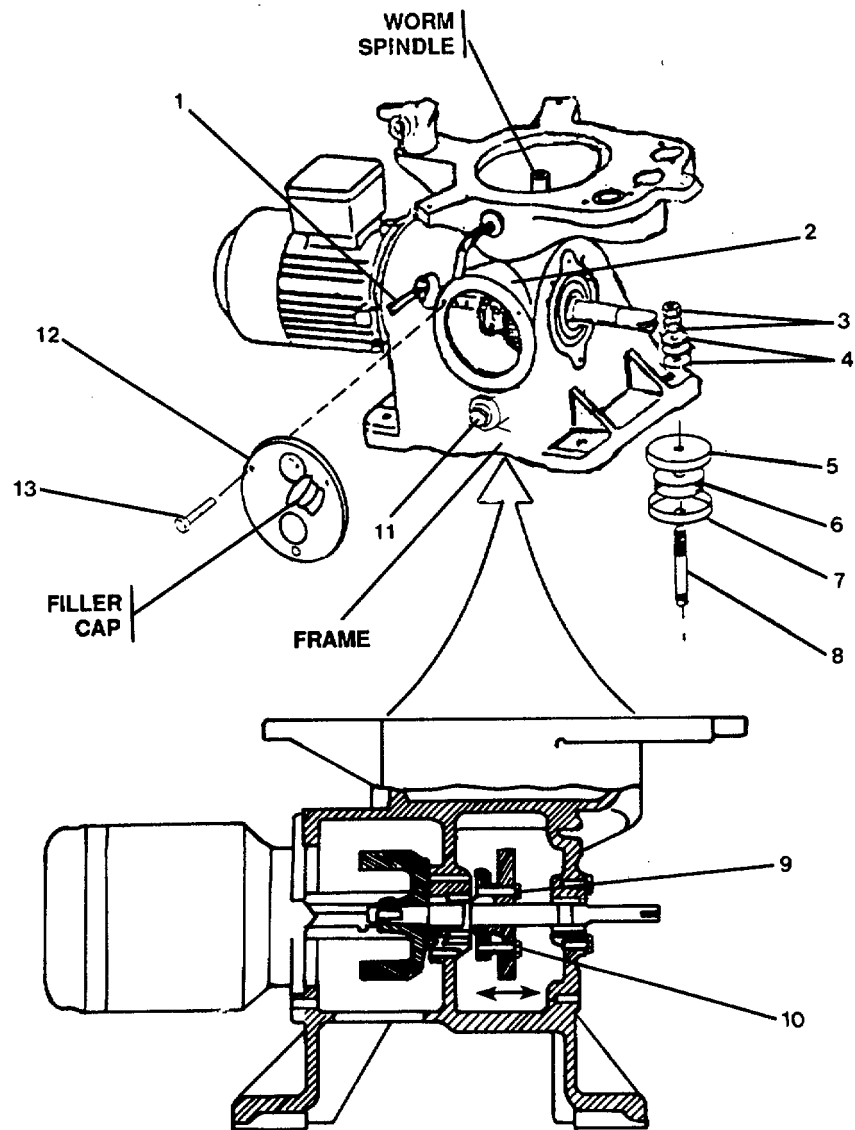

FIGURE 3-10. Purifier Frame Subassembly.

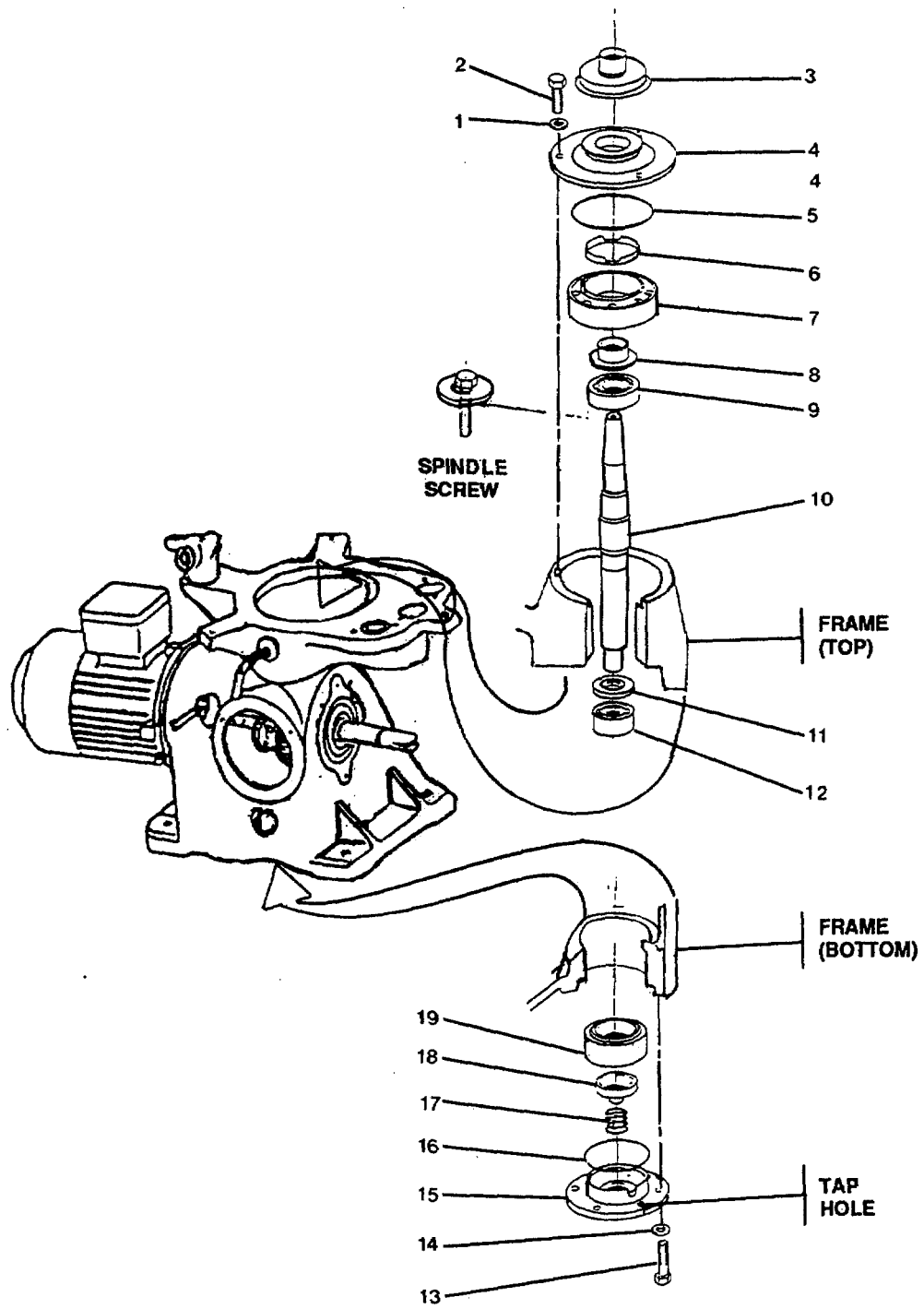

FIGURE 3-11. *Vertical Gear Assembly.*  
3-70

- h. Install screws (13) in tapholes on bearing cover and tighten to force bearing cover out of bottom frame.
- i. Remove bearing cover gasket (16), cylindrical spring (17) and boltguide (18) from bottom frame.
- j. Remove three machine screws (2) and lockwashers (1) from neck bearing cap (4) on top frame.
- k. Remove spindle cap (3) and neck bearing cap.
- l. Remove preformed packing (5).
- m. Install spindle screw onto worm spindle (10).
- n. Pull worm spindle (10) together with bushing (7), ball bearing protection ring (11) and annular ball bearing (12) out of top frame, assisted by spindle screw.
- o. Remove spindle screw from worm spindle.
- p. Slide distance ring (6) and bushing (7) off of grooved ball bearing (9) and sleeve (8).
- q. Use gear puller to remove spherical plain bearing (19) from bottom frame.
- r. Use gear puller to remove sleeve (8), grooved ball bearing (9), annular ball bearing (12) and ball bearing protection ring (11) from worm spindle.

## **REPLACEMENT**

### **NOTE**

Before grooved ball bearing and sleeve or ball bearing protective ring and annular ball bearing are laced over their respective worm spindle end, they must both be heated in oil to a temperature of approximately 176°F (80°C).

- a. Use arbor press to install ball bearing protection ring (11, Figure 3-11) followed by annular ball bearing (12) on worm spindle bottom and grooved ball bearing (9), followed by sleeve (8) over worm spindle.
- b. Use arbor press to install spherical plain bearing (19) to bottom frame.
- c. Position bushing (7) and distance ring (6) over sleeve (8) and grooved ball bearing (9).

**NOTE**

It must be possible to install the worm spindle with bushing and bearings attached, and having bearing on lower spindle to fit into the spherical plain bearing without tapping on the upper spindle end, and to turn it freely by hand. If not, smooth the parts with a very fine emery cloth.

- d. Install spindle screw onto worm spindle.
- e. With aid of spindle screw, install worm spindle (10) into top frame, with annular ball bearing (12) and ball bearing protection ring (11) fitted into spherical plain bearing (19).
- f. Remove spindle screw.
- g. Install preformed packing (5) on top frame.
- h. Position neck bearing cap (4) on top frame.
- i. Install three machine screws (2) and lockwashers (1) and secure neck bearing cap to top frame.
- j. Install spindle cap (3).
- k. Install boltguide (18), cylindrical spring (17) and gasket (16) on worm spindle bottom.
- l. Position bearing cover (15) on bottom frame with mounting screw holes aligned.
- m. Install three machine screws (13) and lockwashers (14) and secure bearing cover to bottom frame.

**NOTE**

- Refer to Figure 3-10 for the remaining replacement procedures.
  - Two soldiers are required.
- n. Lift and position frame on caps (5), rubber cushions (6), caps (7) and mounting studs (8).
  - o. Install four cup springs (4) and hex plain nuts (3) and secure frame to mounting studs.
  - p. Slide worm wheel (10) left to engage with worm spindle.
  - q. Secure worm wheel with hex head screws (9).
  - r. Release brake by turning handle (1) clockwise.
  - s. Position revolution indicator housing (12) on housing (2).

- t. Install three machine screws (13) and secure revolution indicator housing to housing.
- u. Bowl assembly installed as specified in paragraph 3-16 .
- v. Pump connection assembly installed as specified in paragraph 2-18 .
- w. Double gear pump assembly removed as specified in paragraph 2-21 .
- x. Install oil drain screw (11).
- y. Remove filler cap; add oil to gearbox to slightly above center of sight glass on revolution indicator housing.
- z. Install filler cap.

---

**3-18. Replace Horizontal Gear Assembly.**

---

**This task covers:**

**a. Removal**

**b. Replacement**

---

**INITIAL SETUP :**

Tools

Tool kit, general mechanic's,  
5180-00-699-5273

Pressure piece

P/N 2125-9806-000 (8071)

Bearing puller P/N 3375016

Arbor press, 4920-00-373-9376

Equipment Condition

Remove motor as specified in  
para. 2-18 .

Remove double gear pump assembly as  
specified in para. 2-21 .

Materials/Parts

Gear Assembly P/N 2125-4003-010

Oil

Warning Tags, Item 1, Appendix C

---

**REMOVAL**

- a. Release brake by turning handle (3, Figure 3-12) fully clockwise.
- b. Remove oil drain screw (4) and drain oil.
- c. Remove three screws (1) and remove revolution indicator housing (2).

**NOTE**

Refer to Figure 3-13 for remaining removal procedures.

- d. Loosen three machine screws (23) on worm wheel assembly (24). Hold clutch (6) down to prevent worm wheel shaft (13) from turning.
- e. Slide worm wheel (15) right to disengage from worm spindle (not shown).
- f. Loosen threaded pin (1) and slide clutch driver (2) and clutch shoes (3) out of clutch drum (6) and off worm wheel shaft.
- g. Remove socket head screw (4) and flatwasher (5) from worm wheel shaft.
- h. Install pressure piece on end of clutch drum (6) at motor end and screw in to force clutch drum off worm wheel shaft.
- i. Separate clutch drum from worm wheel shaft (13). Remove pressure piece.



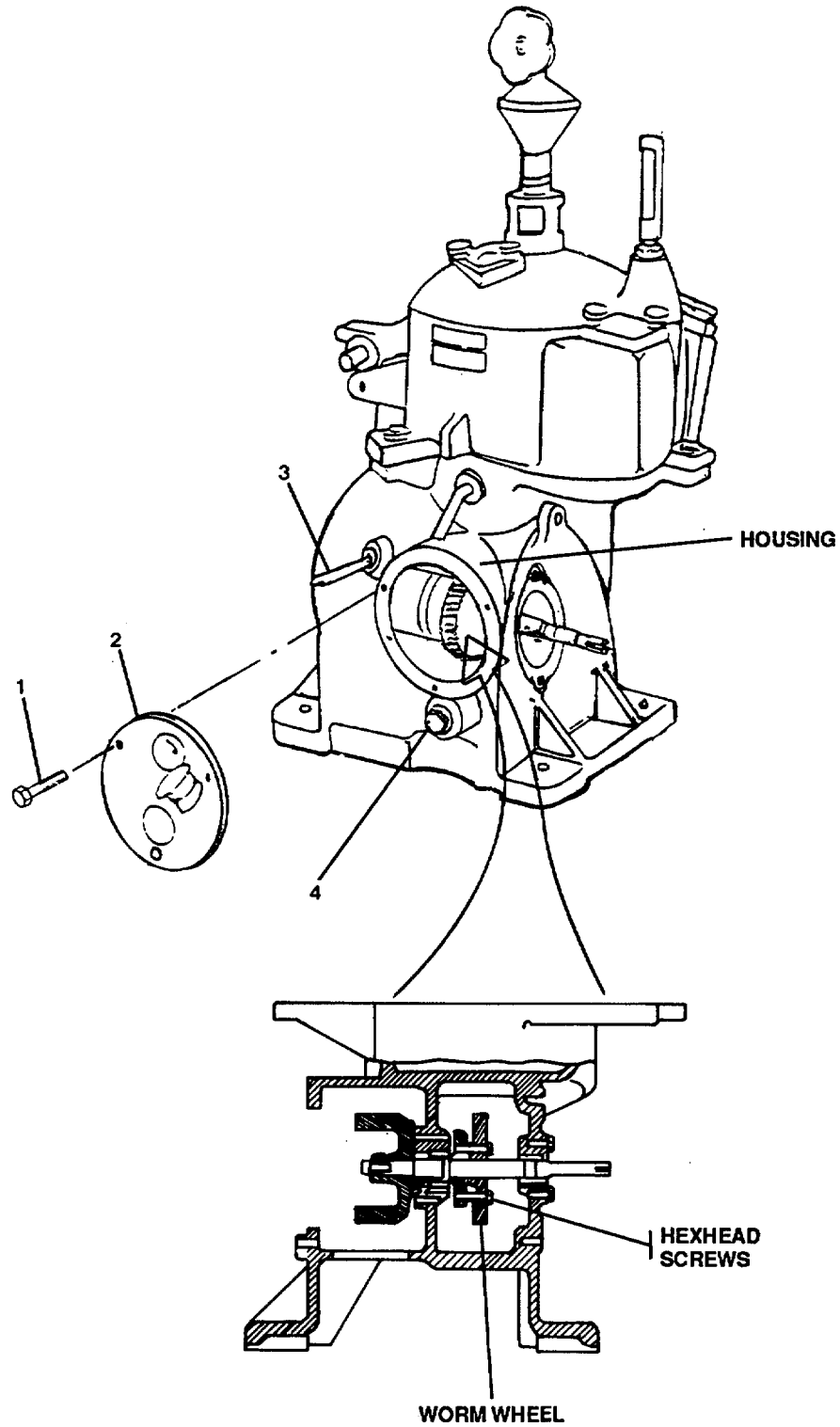

FIGURE 3-12. Purifier Frame Subassembly.  
3-75

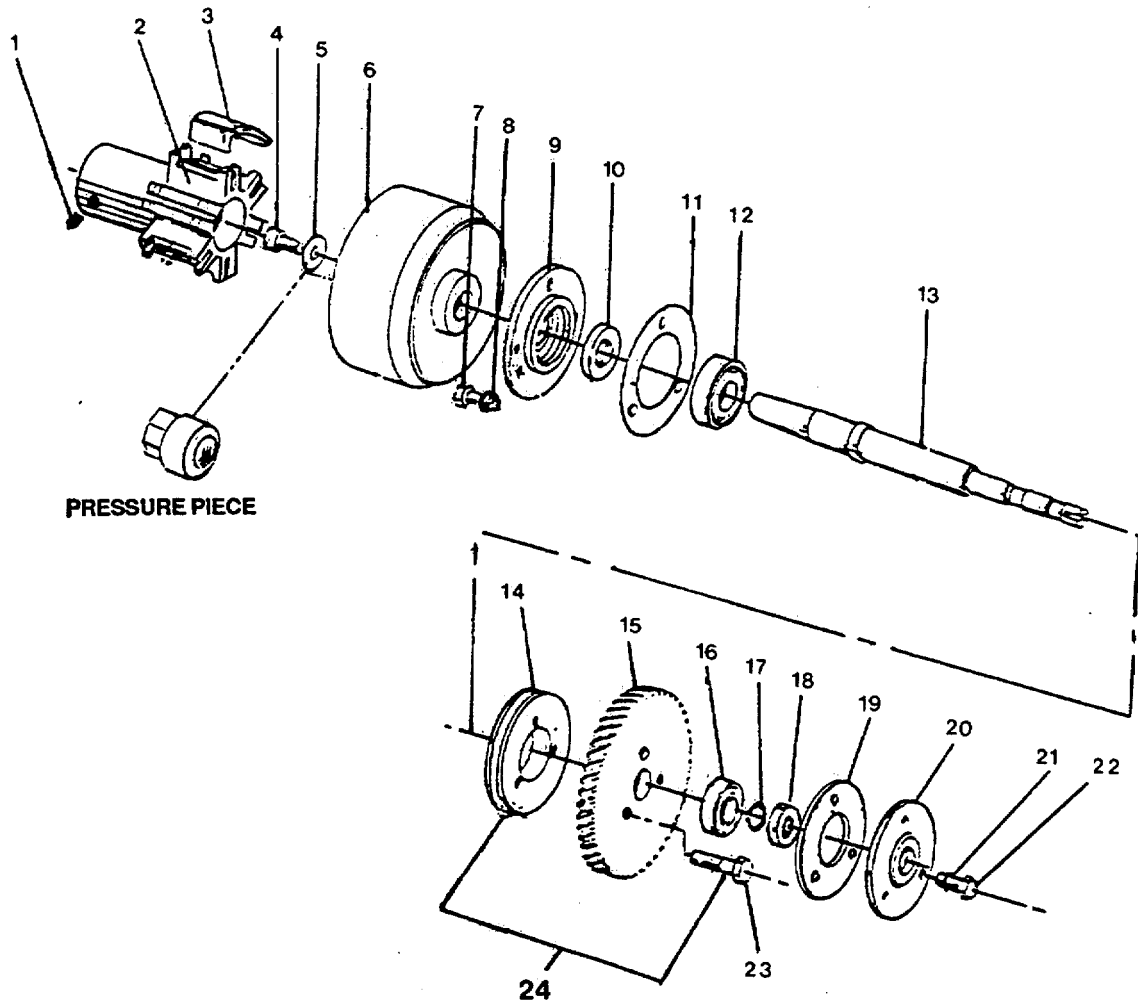

FIGURE 3-13. Horizontal Gear Assembly.

- j. Remove three machine screws (7) and lockwashers (8) from bearing cover (9) on motor side and remove bearing cover, sealing ring (10) and gasket (11) from worm wheel assembly (24).
- k. Remove three machine screws (22) from bearing cover (20) on pump side and remove bearing cover, gasket and sealing ring (18) from housing.
- l. Remove retaining ring (7).
- m. Place a wooden block (or wooden hammer handle) on end of worm wheel shaft (13) and tap lightly with a soft head mallet to drive out shaft towards motor side. Carefully, remove shaft by sliding shaft out of grooved ball bearing (16) while holding worm wheel assembly in position inside housing.
- n. Remove worm wheel assembly (24) from housing.
- o. Use bearing puller to remove grooved ball bearing off of worm wheel shaft.
- p. Use bearing puller to remove grooved ball bearing (16) off of housing on pump side.

## REPLACEMENT

- a. Use arbor press to install grooved ball bearing (16, Figure 3-13) on pump side of housing.
- b. Use arbor press to install grooved ball bearing (12) on worm wheel shaft (13).
- c. Position worm wheel assembly (24) in housing.
- d. Insert worm wheel shaft (13) into housing from motor side and worm wheel assembly (24), grooved ball bearing (16) and through opening on pump side of housing.
- e. Install retaining ring (17).
- f. Install sealing ring (18) gasket (19) and bearing cover (20) to housing on pump side and secure with three machine screws (22).
- g. Install machine gasket (11), sealing ring (10), and bearing cover (9) to worm wheel assembly (24) on motor side and secure with three lockwashers (8) and machine screws (7).
- h. Position clutch drum (6) on worm wheel shaft and secure with flatwasher (5) and socket head screw (4).
- i. Loosen threaded pin (1) and install clutch driver (2) and clutch shoes (3) into clutch drum (6) and on worm wheel shaft.
- j. Slide worm wheel (15) left to engage with worm spindle (not shown).

- k. Secure worm wheel to worm wheel assembly (24) with three machine screws (23) on worm wheel. Hold clutch drum (6) to prevent worm wheel shaft from turning.

**NOTE**

Refer to Figure 3-12 for remaining replacement procedures.

- l. Position revolution indicator housing (2) on housing and secure with three machine screws (1).
- m. Install double gear pump as specified in paragraph 2-21 .
- n. Install motor as specified in paragraph 2-18 .
- o. Install drain screw (4). Fill with oil.
- p. Remove tag and turn on electrical power at P205 power/lighting panel.

---

**3-19. Replace Circulation Heater. (Figure 3-14)**

---

**This task covers:****a. Removal****b. Replacement**

---

**INITIAL SETUP :**ToolsTool kit, general mechanic's,  
5180-00-699-5273Tool kit, electrician's,  
5180-00-391-1087Materials/PartsCirculation heater P/N 9131-1235-009  
Warning tags, Item 1, Appendix CEquipment ConditionElectric power to lube oil purifier  
heater turned OFF at P205power/lighting panel and tagged "Out  
of Service - Do Not Operate."Suction and discharge valves closed and  
tagged "Out of Service - Do Not  
Operate."

---

**REMOVAL**

- a. Remove four screws (6).
- b. Separate and position covers (5) with thermostat control circuit leads (7) clear of opening to junction box (4).
- c. Tag and disconnect electrical wiring at junction box.
- d. Disconnect fittings (3) from junction box.
- e. Remove input voltage line.
- f. Install thermostat control circuit leads and cover.
- g. Install four screws (6) and secure junction box cover.
- h. Disconnect piping from heater (8) at unions (1).
- i. Remove four machine screws (2).
- j. Remove circulation heater.

**REPLACEMENT**

- a. Position circulation heater (8).
- b. Install four machine screws (2) and secure heater to support bracket.
- c. Connect piping to heater at unions (1).

**Change 1 3-79**

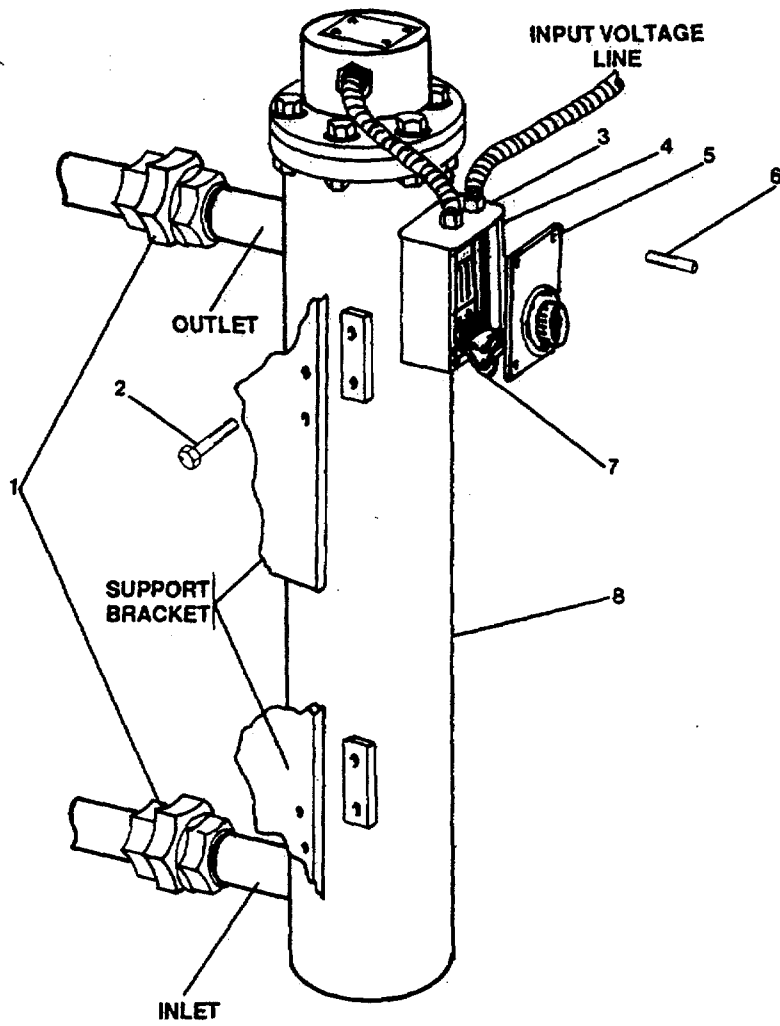

FIGURE 3-14. Circulation Heater.  
3-80

- d. Remove four screws (6).
- e. Separate and position cover (5) and thermostat control leads (7) clear of opening to junction box (4).
- f. Install input voltage line.
- g. Connect fittings (3) on junction box.
- h. Connect electrical wiring at junction box. Remove tags.
- i. Install thermostat control circuit leads and cover.
- j. Install four screws (6) and secure cover to junction box (4).
- k. Open suction and discharge valves. Remove tags.
- l. Restore power to lube oil purifier heater. Remove tags.

---

**3-20. Replace Diesel Fuel Oil Filter/Separator. (Figure 3-15)**

---

**This task covers:****a. Removal****b. Replacement**

---

**INITIAL SETUP :**Tools

Tool kit, general mechanic's,  
5180-00-699-5273  
Torque wrench, kit  
P/N 3377216

Equipment Condition

Shut down - TM 55-1905-223-10  
Suction and discharge valves  
closed and tagged "Out of Service -  
Do Not Operate."

Materials/Parts

Diesel fuel oil filter/separator  
P/N 690224  
Warning tags, Item 1, Appendix C

---

**REMOVAL**

- a. Open vent valve (2) to relieve pressure in housing (1).
- b. Open drain valve (8) and completely drain liquid from housing.
- c. Remove four nuts (4), lockwashers (5) and bolts (6) to separate flange (9) assembly from drain plate.
- d. Disconnect flange assembly from drain piping at union (7).
- e. Remove flange (9) assembly and gasket (10).
- f. Remove four nuts (15), lockwashers (16) and bolts (19) to separate flange (18) assembly from inlet plate.
- g. Disconnect flange assembly from suction piping at union elbow.
- h. Remove flange (18) assembly and gasket (17).
- i. Repeat steps g. through i. to remove flange (3) assembly from outlet plate.
- j. Carefully secure unit to prevent shifting or movement.
- k. Remove nuts (11), lockwashers (12) and bolts (13) from each of four legs (14) of unit.
- l. Remove attaching harness or straps from unit.
- m. Remove diesel fuel oil filter/separator.

**Change 1 3-82**



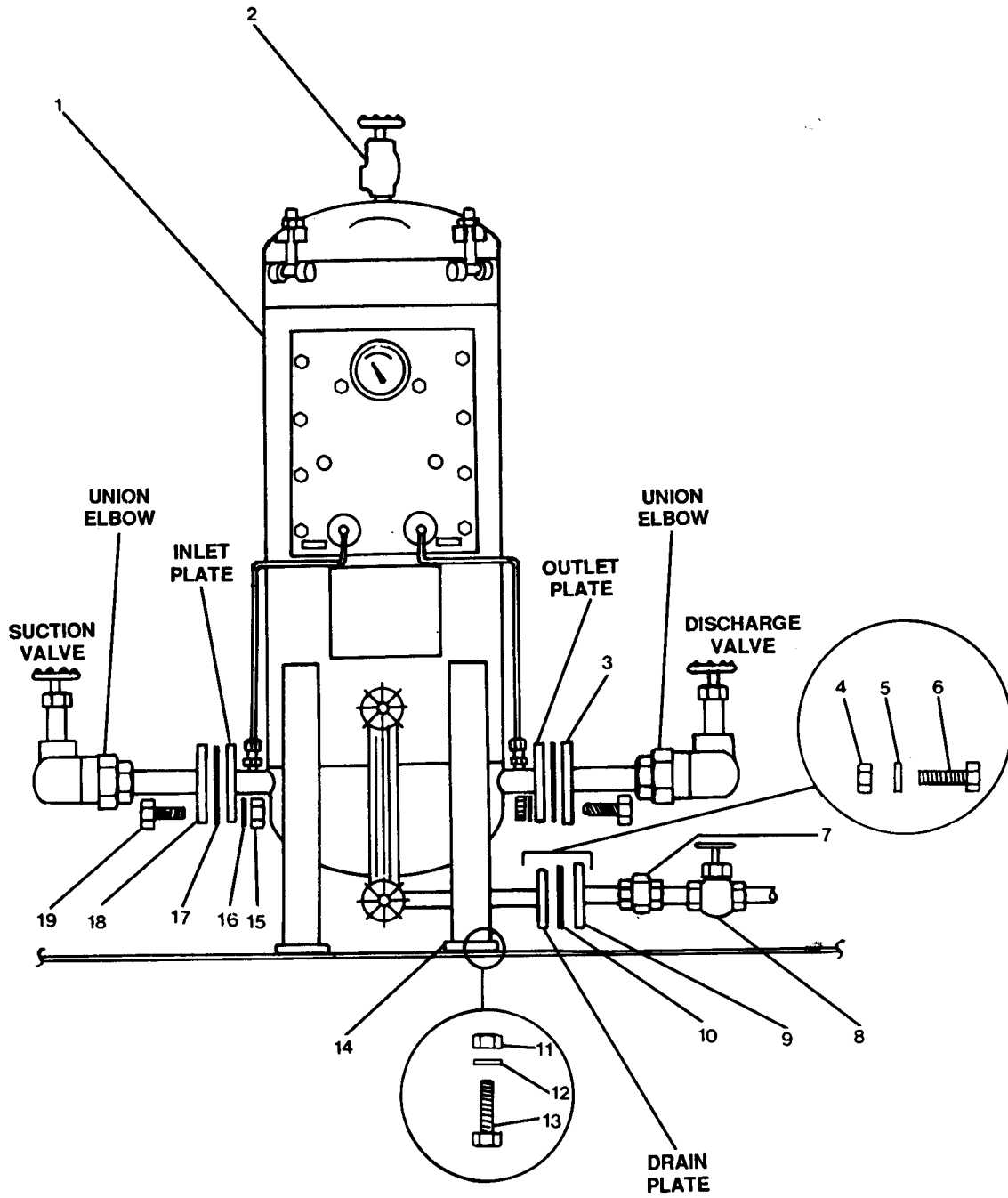

FIGURE 3-15. Diesel Fuel Oil Filter/Separator.

**REPLACEMENT**

- a. Carefully position fuel oil filter/separator on mounting foundation.
- b. Install bolts (13), lockwashers (12) and nuts (11) to each of four legs (14) of unit. Tighten each nut to a torque value of 250 ft-lb (339 N·m).
- c. Position gasket (17) and flange (18) assembly on inlet plate.
- d. Connect flange assembly to suction piping at union elbow.
- e. Install four bolts (19), lockwashers (16) and nuts (15) to secure flange (18) assembly to inlet plate. There are no torque requirements.
- f. Repeat steps c. through e. to install flange (3) assembly to outlet plate.
- g. Position gasket (10) and flange (9) assembly on drain plate.
- h. Connect flange assembly to drain piping at union (7).
- i. Install four bolts (6), lockwashers (5) and nuts (4) to secure flange (9) assembly to drain plate. There are no torque requirements.
- j. Close drain valve (8).
- k. Open discharge valve. Remove tags.

**WARNING**

To prevent injury to personnel, ensure that the ship's vent valve is open and that a low pressure (10 psig or less) is used to fill filter housing until all air has escaped.

- l. Open suction valve. Remove tags.
- m. Refer to initial start-up procedures in TM 55-1905-223-10 .

**3-21. Replace Oil/Water Separator. (Figure 3-16)**

**This task covers:**

**a. Removal**

**b. Replacement**

**INITIAL SETUP:**

Tools

Tool kit, general mechanic's,  
5180-00-699-5273

Materials/Parts

Oil/water separator  
P/N VGS-10

Equipment Condition

Drain oil and water from the three vessels (1), (2), and (3). Refer to paragraph 2-29 .

Source power to alternating current motors (oil/water) tagged and disconnected from motor control box assembly as specified in paragraph 2-26 .

**REMOVAL**

- a. Drain water from water pump by removing bottom drain plug in the pump housing (Sheet 1).
- b. Drain sensing module assembly (2, Sheet 2).
  - (1) Open sensing module cleanout valve (3).
  - (2) Open sensing module drain valve (1).
- c. Remove four nuts, lockwashers and bolts each from flanges and disconnect flanges at the system inlet (8, Sheet 3), clean water discharge (6), recirculation line (5), and the oil discharge line (7).
- d. Remove eight bolts (10) securing skid base (9) to deck plate.
- e. Attach lifting sling to four lifting points on skid base.
- f. Remove oil/water separator.

**REPLACEMENT**

- a. Position oil/water separator properly and attach skid base (9) to deck plate with eight bolts (10). There are no torque requirements.
- b. Remove lifting sling from four lifting points on skid base.

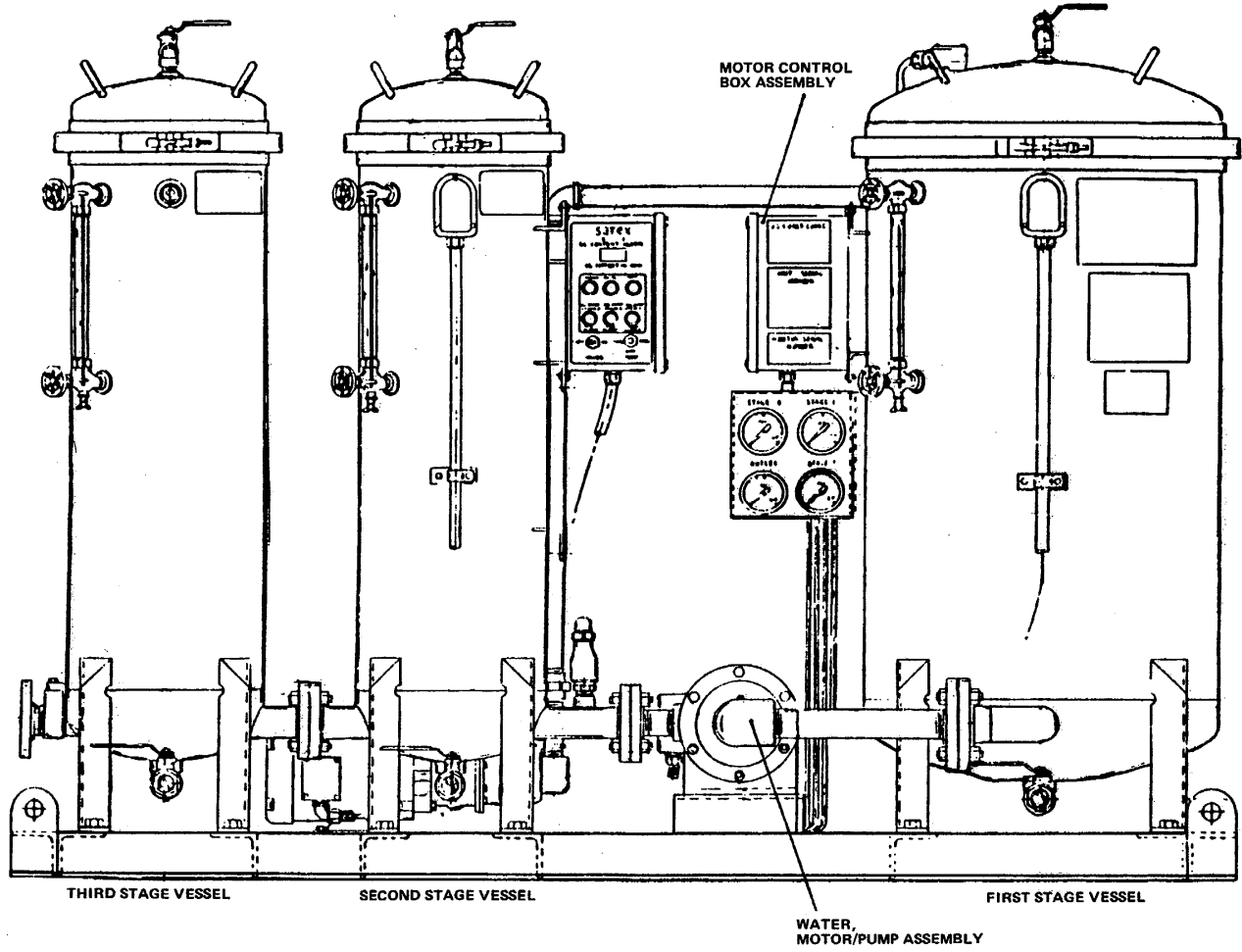

FIGURE 3-16. Oil/Water Separator (Sheet 1 of 3).

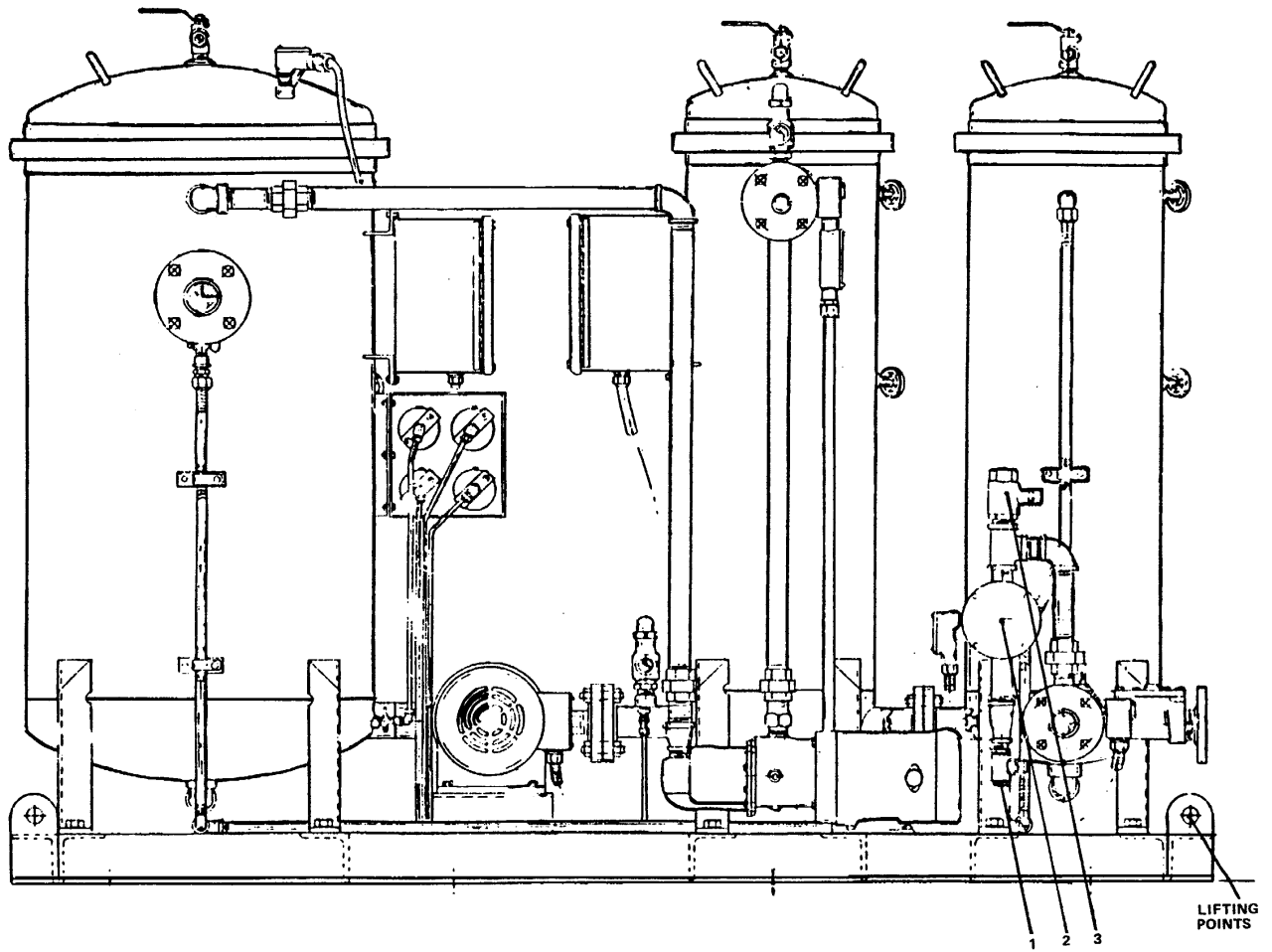

FIGURE 3-16. Oil/Water Separator (Sheet 2 of 3).

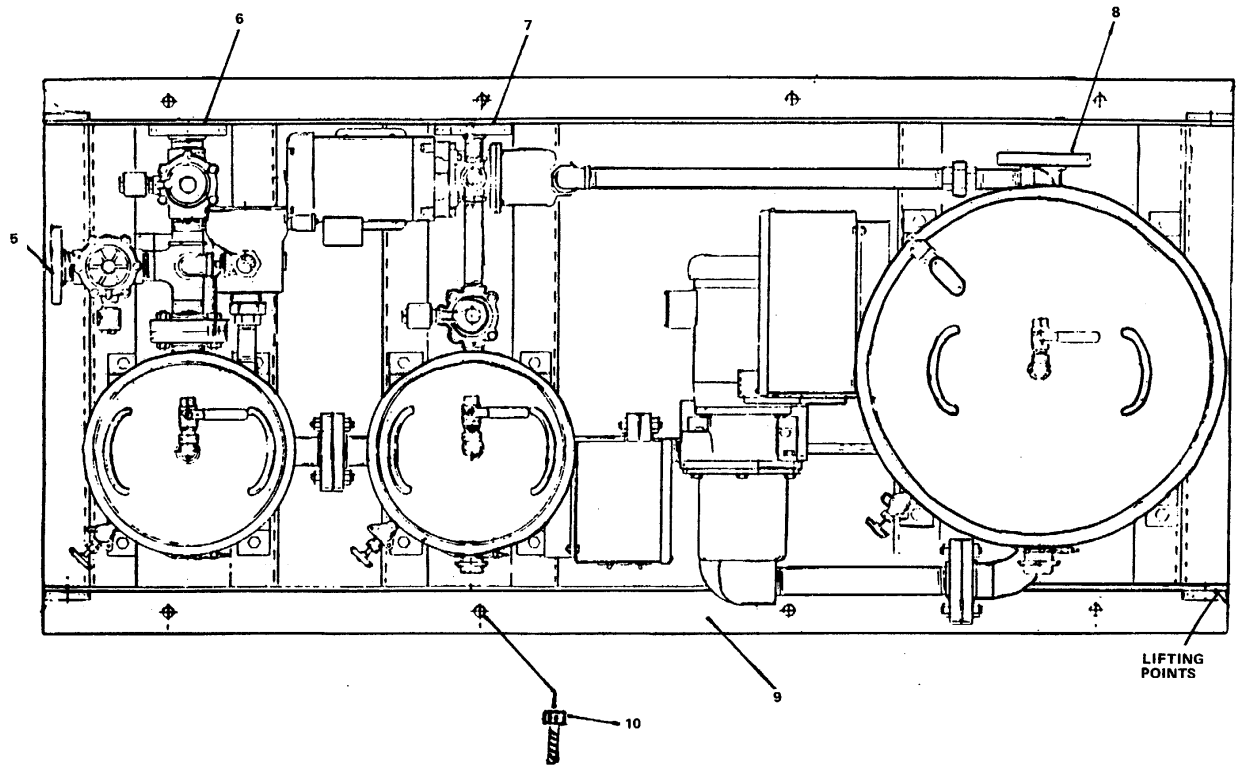

FIGURE 3-16. Oil/Water Separator (Sheet 3 of 3).

- c. Install four bolts, lockwashers and nuts each; connect system inlet (8), clean water discharge (6), recirculation line (5) and the oil discharge line (7). Tighten bolts securely. There are no torque requirements.
- d. Drain sensing module assembly (2 Sheet 2).
  - (1) Close sensing module drain valve (1).
  - (2) Close sensing module cleanout valve (3).
- e. Install drain plug on bottom of pump housing (Sheet 1).
- f. Source power to alternating current motors (oil/water) connect to motor control box assembly as specified in paragraph 2-26 .

---

**3-22. Repair Oil/Water Separator.**

---

This task covers:

- a. Disassembly,                      b. Repair,                      c. Assembly.
- 

**INITIAL SETUP:**Tools

Tools required are listed by referenced paragraphs.

Equipment Condition

Electrical power removed and tagged "Out of Service - Do Not Operate" as directed by referenced paragraphs.

Materials/Parts

Refer to referenced paragraphs.

---

**DISASSEMBLY**

- a. Motor control box assembly. Refer to paragraph 3-23 .
- b. Gage panel assembly. Refer to paragraph 2-27 .
- c. Control module assembly. Refer to paragraph 2-28 .
- d. Vessel subassembly (first stage). Refer to paragraph 3-25 .
- e. Plate assembly. Refer to paragraph 3-26 .
- f. Vessel subassembly (second stage). Refer to paragraph 3-30 .
- g. Vessel subassembly (third stage). Refer to paragraph 3-28 .
- h. Motorized pump (oil).
  - (1) Position motorized pump (15, Figure 3-17) on a clean, flat surface.
  - (2) Remove eight machine screws (8) securing housing (7) to pump body.
  - (3) Separate and remove housing from pump body.
  - (4) Slide stator ring (6) and stator (9) off of rotor (5).
  - (5) Separate rotor (5) from universal joint (3) by using a punch to remove pin (4). Support rotor when removing pin. Retain pin (4) for assembly.
  - (6) Separate universal joint (3) from motor shaft by using a punch through outlet port on pump body to remove pin (2). Retain pin (2) for assembly.
  - (7) Slide universal joint off of motor shaft and out of pump body.



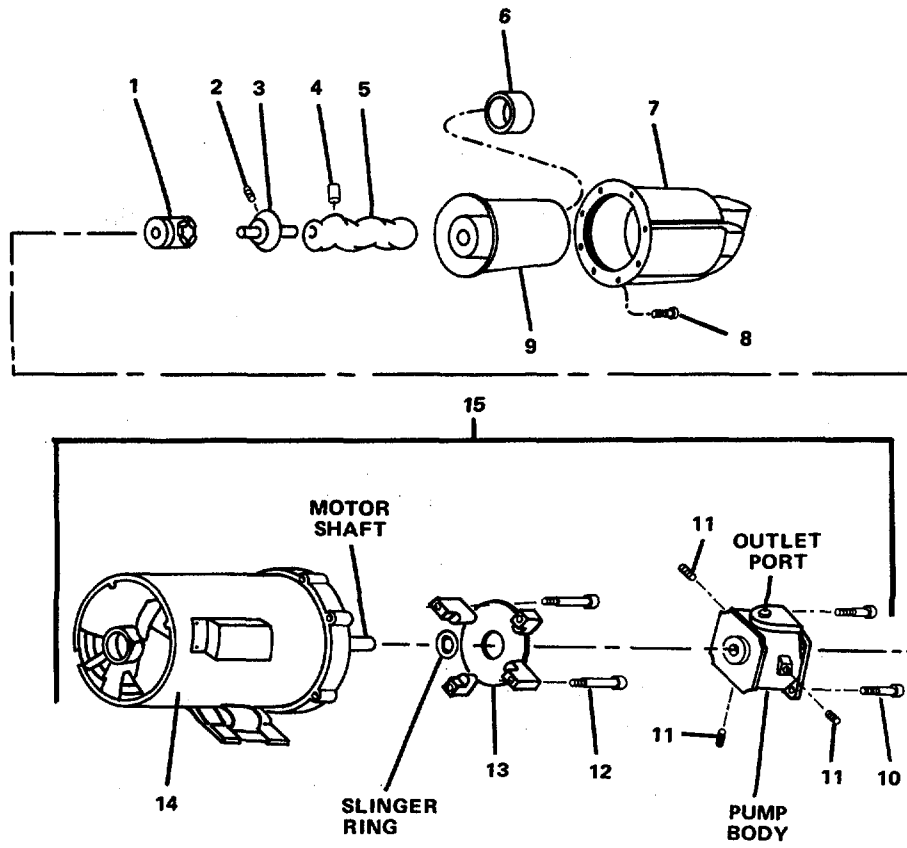

FIGURE 3-17. Motorized Oil Pump.

**NOTE**

If any part of mechanical seal is broken or damaged, the complete seal assembly must be replaced.

- (8) Carefully slide mechanical seal (1) off motor shaft and out of pump body.
- (9) Remove four machine screws (1) securing pump body to fluid control ring (13).
- (10) Separate and remove pump body from motor shaft and fluid control ring.
- (11) Remove three pipe plugs (11) from pump body.
- (12) Remove four machine screws (12) securing fluid control ring (13) to pump drive motor (14).
- (13) Separate and remove fluid control ring (13) and slinger ring from pump drive motor (14) shaft.

## i. Motorized pump (water).

- (1) Position motorized pump (14, Figure 3-18) on a clean, flat surface.
- (2) Remove six machine screws (7) securing housing (6) to motorized pump.
- (3) Separate and remove housing (6) from pump.
- (4) Remove pipe plug (8) from housing.
- (5) Slide stator (9) off of rotor (5).
- (6) Separate rotor (5) from universal joint (3) by using a punch to remove pin (4) Support rotor when removing pin. Retain pin for assembly.
- (7) Separate universal joint (3) from motor shaft by using a punch through outlet port on pump body to remove pin (2). Retain pin for assembly.
- (8) Slide universal joint off of motor shaft and out of motorized pump (14).

**NOTE**

If any part of mechanical seal is broken or damaged, the complete seal assembly must be replaced.

- (9) Carefully slide mechanical seal (1) off motor shaft and out of motorized pump (14).
- (10) Remove four machine screws (11) securing motorized pump (14).
- (11) Separate and remove motorized pump (14) and fluid control ring (12) from motor shaft.
- (12) Remove pipe plug (10) from motorized pump (14).

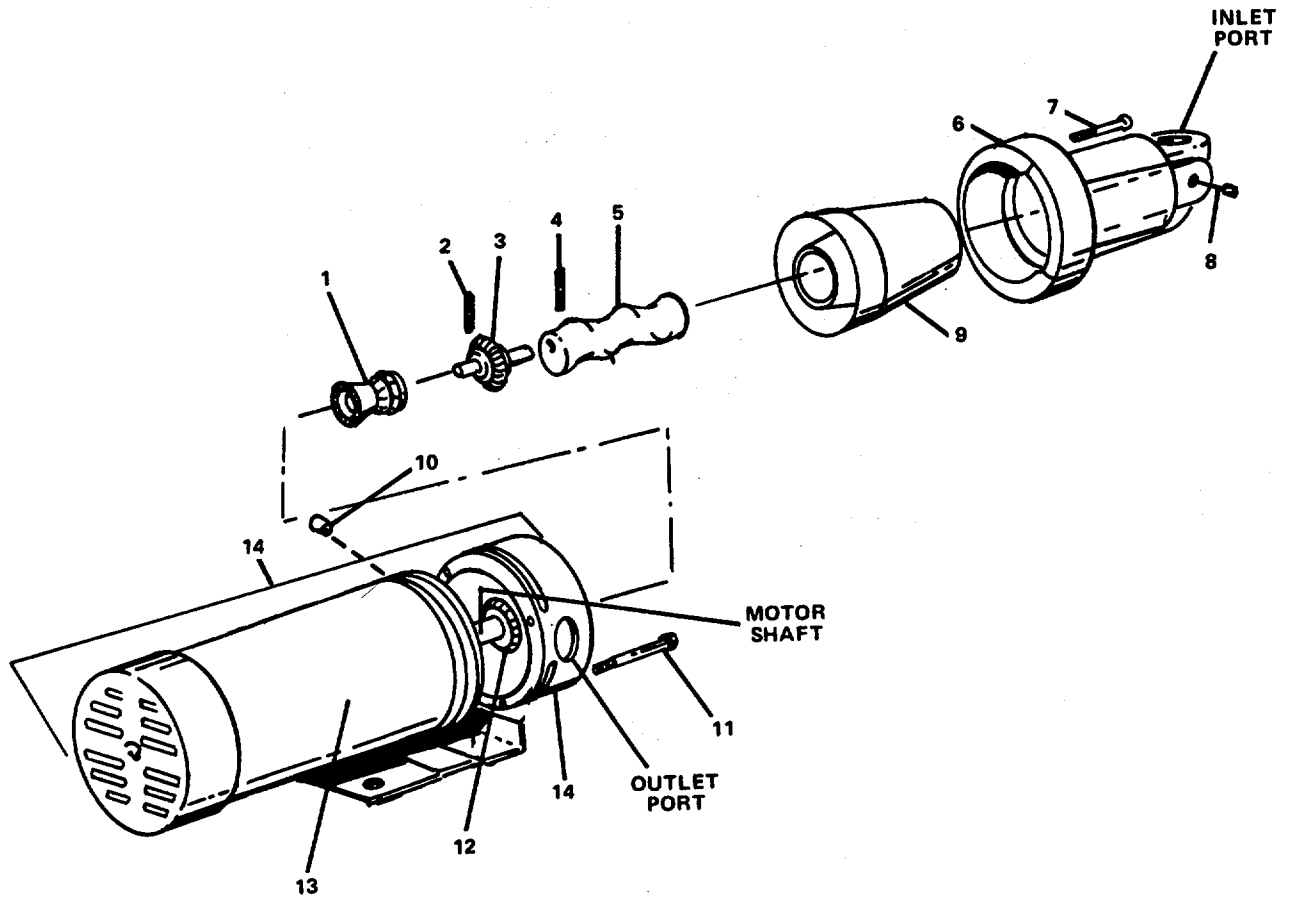

FIGURE 3-18. Motorized Water Pump.

## REPAIR

Repair of oil/water separator consists of replacement parts listed in the above referenced paragraphs.

## ASSEMBLY

- a. Sensing module assembly. Refer to paragraph 4-18 .
- b. Motorized pump (water). Refer to paragraph 4-20 .
- c. Motorized pump (oil). Refer to paragraph 4-19 .
- d. Vessel Subassembly (third stage). Refer to paragraph 3-28 .
- e. Vessel Subassembly (second stage). Refer to paragraph 3-30 .
- f. Plate assembly. Refer to paragraph 3-26 .
- g. Vessel Subassembly (first stage). Refer to paragraph 3-25 .
- h. Control module assembly. Refer to paragraph 2-28 .
- i. Gage panel assembly. Refer to paragraph 2-27 .
- j. Motor control box assembly. Refer to paragraph 3-26 .

---

**3-23. Repair Motor Control Box Assembly. (Figure 3-19)**

---

This task covers:

- a. Disassembly,                      b. Repair,                      c. Assembly.
- 

**INITIAL SETUP:**Tools

Tool kit, general mechanic's,  
5180-00-699-5273  
Tool kit, electrician's,  
U 5180-00-391-1087

Equipment Condition

Motor control box assembly removed as  
specified in paragraph 2-26 .

Materials/Parts

Solid state relay P/N 480D10-12  
Relay P/N LRI-D09307  
Electromagnetic relay P/N 20114-82  
Contactor P/N LCI-EC03M  
Warning tags, Item 1, Appendix C

---

**DISASSEMBLY**

- a. Motor control box assembly.

Remove four hex plain nuts (19), lockwashers (18) and machine bolts (17) to remove motor control box assembly (20).

- b. Panel.

- (1) Position motor control box assembly (20) on a clean, flat surface.
- (2) Remove four machine screws (16) securing panel (4) to housing (21).
- (3) Remove panel from housing.
- (4) Position panel for disassembly.

- c. Solid state relay SR1 through SR4.

- (1) Loosen four terminal screws (1) on relay (3).
- (2) Tag and disconnect electrical leads.
- (3) Remove two mounting screws (2).

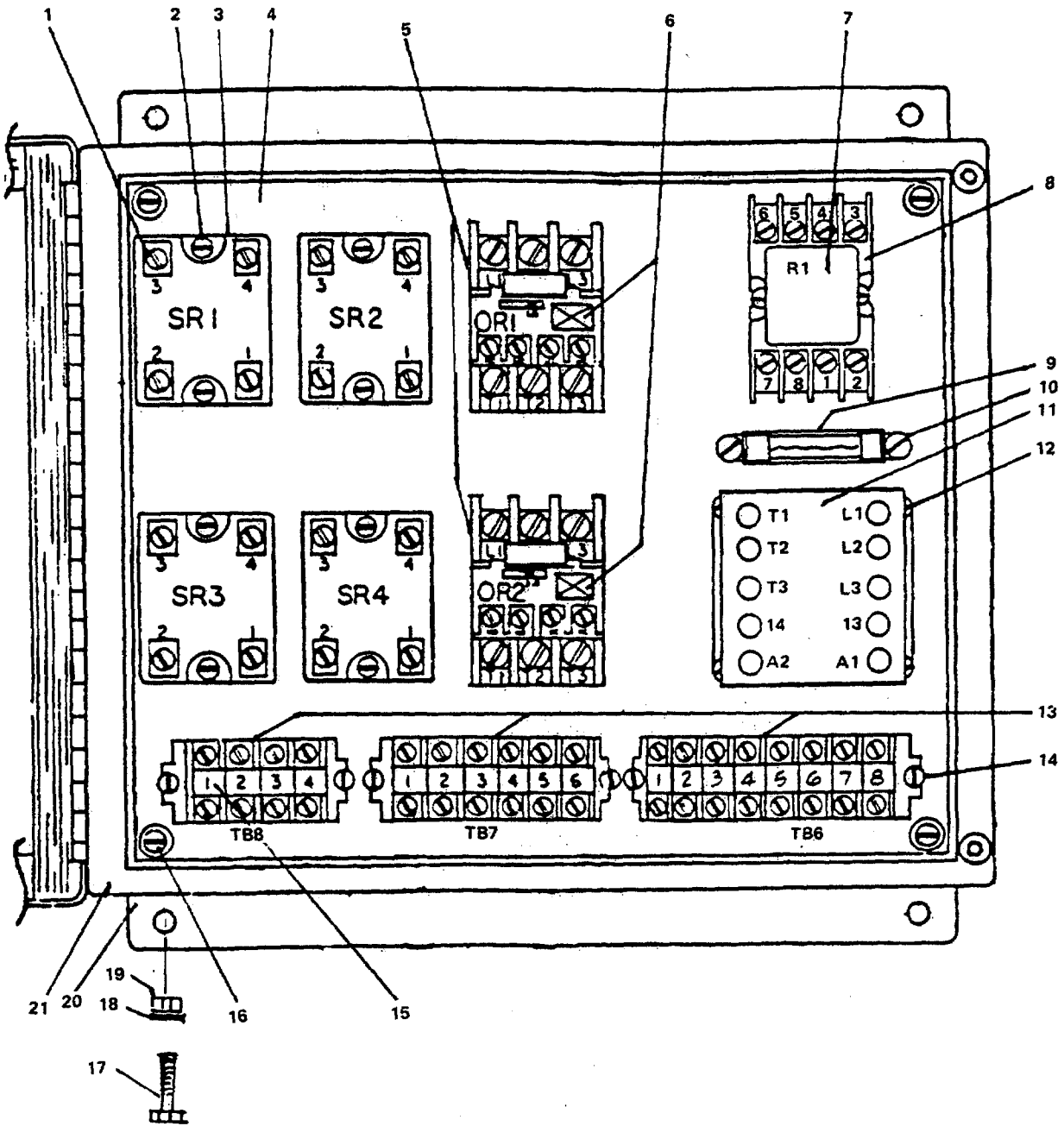

FIGURE 3-19. Motor Control Box Assembly.

(4) Remove relay (3) from panel (4). Note orientation of relay for assembly.

(5) Repeat steps (1) through (4) to remove three remaining relays.

d. Relay OR1, OR2 (1.6 - 2.5 AMP)

Remove plug in relays (6) from each mounting pad (5) of ORI and OR2, by pulling each relay out of its socket. Note orientation of relay for assembly.

e. Electromagnetic relay (24 Vdc) R1.

Remove plug in relay (7), by pulling relay out of socket (7). Note orientation of relay for assembly.

f. Fuseholder block.

(1) Tag and, using a soldering iron, unsolder electrical wires from rear of fuseholder block (9).

(2) Remove two machine screws (10).

(3) Remove fuseholder block from panel (4).

g. Contactor.

(1) Tag and, using a soldering iron, unsolder electrical wires from contactor (11).

(2) Remove four machine screws (12).

(3) Remove contactor.

h. Terminal board end TB6, TB7, TB8.

(1) Tag and, using a soldering iron, unsolder electrical wires from each terminal board (15) on rear of terminal board ends (13).

(2) Remove two machine screws (14) from each of three terminal board ends.

(3) Remove terminal board ends.

## REPAIR

Repair of motor control box assembly consists of replacing solid state relays (3), relays (6), electromagnetic relay (7), and contactor (11).

## ASSEMBLY

a. Terminal board end TB6, TB7, TB8.

(1) Position panel (4) on clean flat surface.

- (2) Position terminal board ends (13) on panel.
- (3) Install two machine screws (14) and secure each of three terminal board ends to panel.
- (4) Solder electrical wires to each terminal board (15) on rear of terminal board ends (13).
- (5) Remove tags.

b. Contactor.

- (1) Position contactor (11) on panel (4).
- (2) Install four machine screws (12) and secure contactor to panel.
- (3) Solder electrical wires to contactor.
- (4) Remove tags.

c. Fuseholder block.

- (1) Position fuseholder block (9) on panel.
- (2) Install two machine screws and secure fuseholder block to panel.
- (3) Solder electrical wires to rear of fuseholder block.
- (4) Remove tags.

d. Electromagnetic relay (240 Vdc) R1.

Install relay (7) by inserting relay into socket (8) as noted during disassembly.

e. Relay OR1, OR2 (1.6 - 2.5 AMP)

Install relays (6) by inserting each relay into its mounting pad (5) of OR1 and OR2 as noted during disassembly.

f. Solid state relay SR1 through SR4.

- (1) Position relay (3) on panel as noted during disassembly.
- (2) Install two machine screws (2) and secure relay to panel.
- (3) Loosen four terminal screws (1) on relay.
- (4) Connect electrical leads.
- (5) Secure leads on relay with terminal screws.
- (6) Remove tags.
- (7) Repeat steps (1) through (6) for remaining three relays, SR2, SR3 and SR4.



g. Panel.

- (1) Position housing (21) on a clean, flat surface.
- (2) Position panel (4) on housing.
- (3) Install four machine screws (16) and secure panel to housing.

h. Motor control box assembly.

Install motor control box assembly (20) with four machine bolts (17), lockwashers (18) and hex plain nuts (19).



e. Motor control box assembly replaced as specified in paragraph 2-26 .

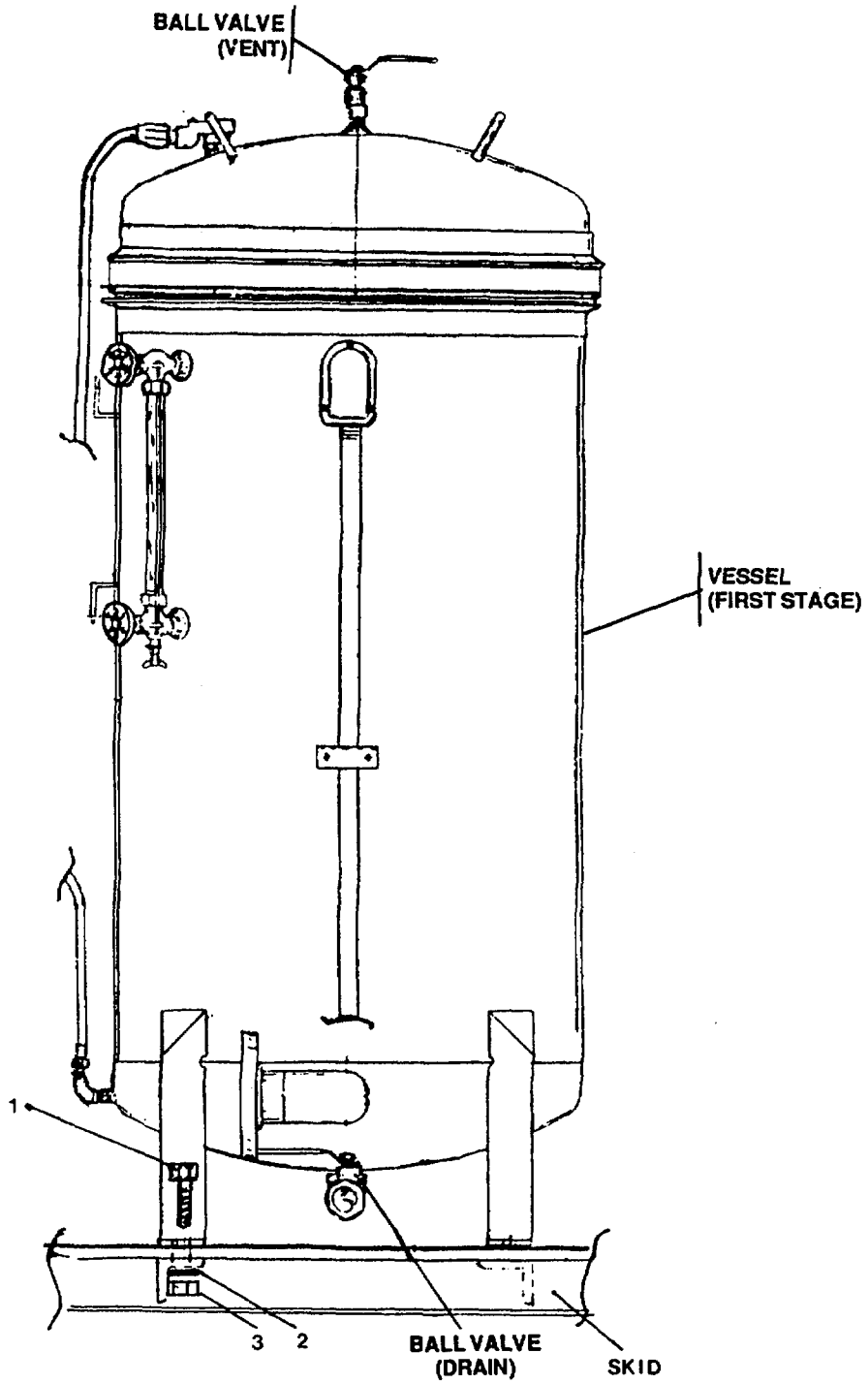

FIGURE 3-20. Vessel Subassembly (First Stage).

---

**3-25. Repair Vessel Subassembly (First Stage). (Figure 3-21)**

---

**This task covers:**

- a. Disassembly,                      b. Repair,                      c. Assembly.**
- 

**INITIAL SETUP:**Tools

Tool kit, general mechanic's,  
5180-00-699-5273

Equipment Condition

Vessel subassembly (first stage)  
removed as specified in para. 3-24 .

Materials/Parts

Ball valve P/N VB62, VB57  
Liquid transmitter P/N 8392  
Level switch P/N SX77  
Preformed packing P/N GA22  
Float switch P/N 1638

---

**DISASSEMBLY**

- a. Disconnect ball valve (22) and pipe nipple (23).
- b. Disconnect stop check valve (18).
- c. Disconnect pipe nipple (17) and pipe elbow (16) from vessel subassembly (19).
- d. Disconnect sight glass (21).
- e. Disconnect and remove liquid transmitter (20).
- f. Disconnect ball valve (13) pipe elbow (14) and pipe nipple (12).
- g. Remove ten machine screws (8) and remove cover.
- h. Remove level switch (9) and bushing (10).
- i. Remove two U-bolts (1) from brackets (2) and (32).
- j. Disconnect pipe nipple (30), pipe elbow (29), pipe nipple (28), stop check valve (27), and pipe nipple (26).
- k. Remove ten hex plain nuts (3), lockwashers (4, 6) and machine bolts (7) from brackets (2, 5) and baffles (25, 31).

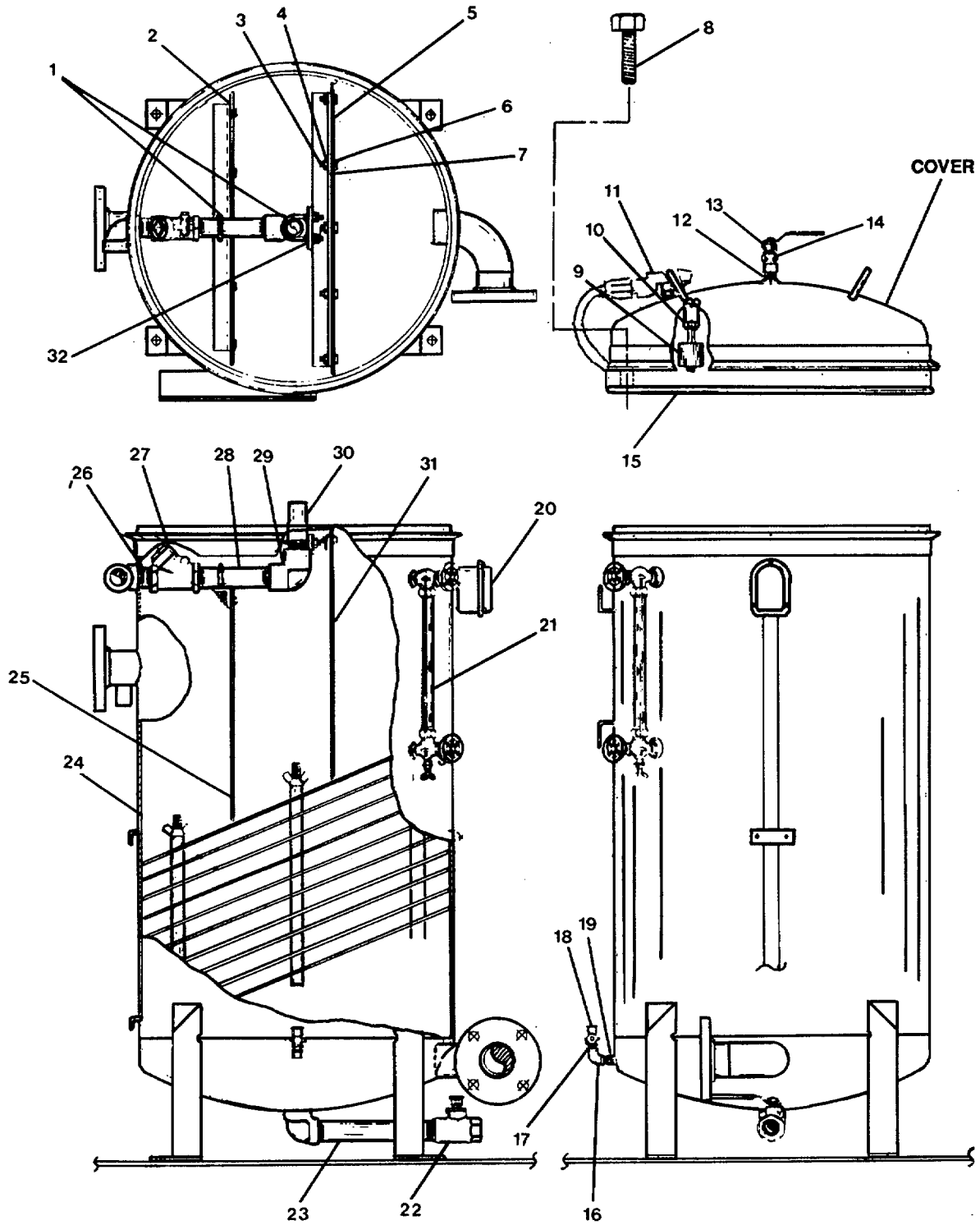

FIGURE 3-21. Vessel Subassembly (First Stage).

- l. Remove brackets (2, 5) and (32 part of bracket 5).
- m. Lift baffles (25, 31) out of vessel (24).
- n. Remove preformed packing (15).
- o. Disconnect float switch (11).

## REPAIR

Repair of vessel subassembly (first stage) consists of replacing ball valves (22), (13), liquid transmitter (20), level switch (9), preformed packing (15), and float switch (11).

## ASSEMBLY

- a. Connect float switch (11).
- b. Install preformed packing (15).
- c. Lower baffles (31, 25) into vessel (24).
- d. Position brackets (2, 5) and (32 part of bracket 5) over mounting bolts holes on baffles (31 and 25).
- e. Install ten machine bolts (7) lockwashers (6, 4) and hex plain nuts (3) and secure brackets to baffles.
- f. Connect pipe nipple (26), stop check valve (27), pipe nipple (28), pipe elbow (29) and pipe nipple (30).
- g. Install two U-bolts (1) on brackets (32 and 2).
- h. Install bushing (10) and level switch, (9).
- i. Position cover on vessel.
- j. Install ten machine screws (8) and secure cover to vessel (24).
- k. Connect pipe nipple (12), pipe elbow (14) and ball valve (13).
- l. Install and connect liquid transmitter (20).
- m. Connect sight glass (21).
- n. Connect pipe elbow (16) and pipe nipple (17- to vessel subassembly (19).
- o. Connect stop check valve (18).
- p. Connect pipe nipple (23) and ball valve (22).
- q. Vessel subassembly (first stage) replaced as specified in paragraph 3-22 .

---

**3-26. Replace/Repair Plate Assembly.**

---

This task covers:

- |              |                 |            |
|--------------|-----------------|------------|
| a. Removal,  | b. Disassembly, | c. Repair, |
| d. Assembly, | e. Replacement. |            |
- 

**INITIAL SETUP:**Tools

Tool kit, general mechanic's,  
5180-00-699-5273

Equipment Condition

Vessel cover and baffles removed as  
specified in para. 3-25 .

Materials/Parts

Plate assembly P/N 1291-2  
Brush, Item 29, Appendix C  
Solvent, Item 37, Appendix C

---

**REMOVAL**

Lift plate assembly (1) out of vessel (2, Figure 3-22).

**DISASSEMBLY**

- a. Disassemble plate assembly (Figure 3-23).
  - (1) Remove five self-locking wing nuts (1) and flat washers (3) from top of five threaded rod ends (2) on plate assembly.
  - (2) Remove five sleeve spacers (6) from threaded rod ends at top of plate assembly.
  - (3) Alternately remove ten elliptical plates, one at a time, with five sleeve spacers (5) by sliding off the top of the five threaded rod ends (2).
  - (4) Remove five sleeve spacers (6) at bottom of threaded rod ends.
- b. Clean plates. Thoroughly clean each of the ten elliptical plates using brush and solvent.

**REPAIR**

Repair of plate assembly consists of replacing plate assembly (1).

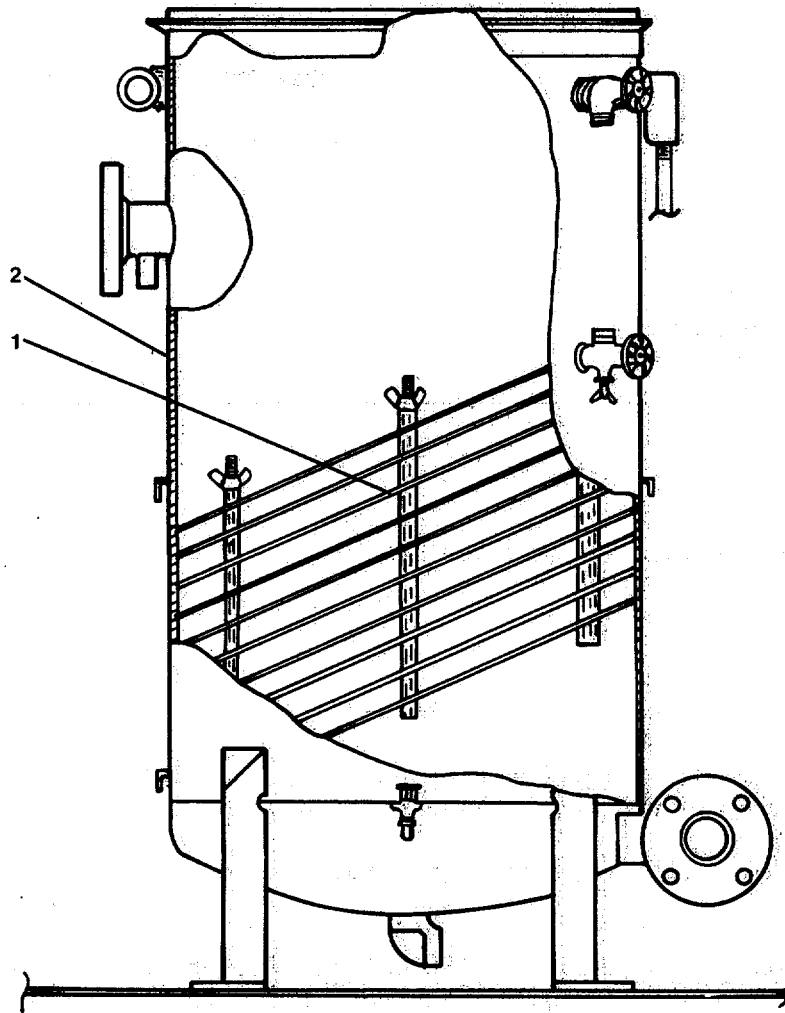

**LEFT SIDE VIEW**

*FIGURE 3-22. Plate Assembly Removal.*



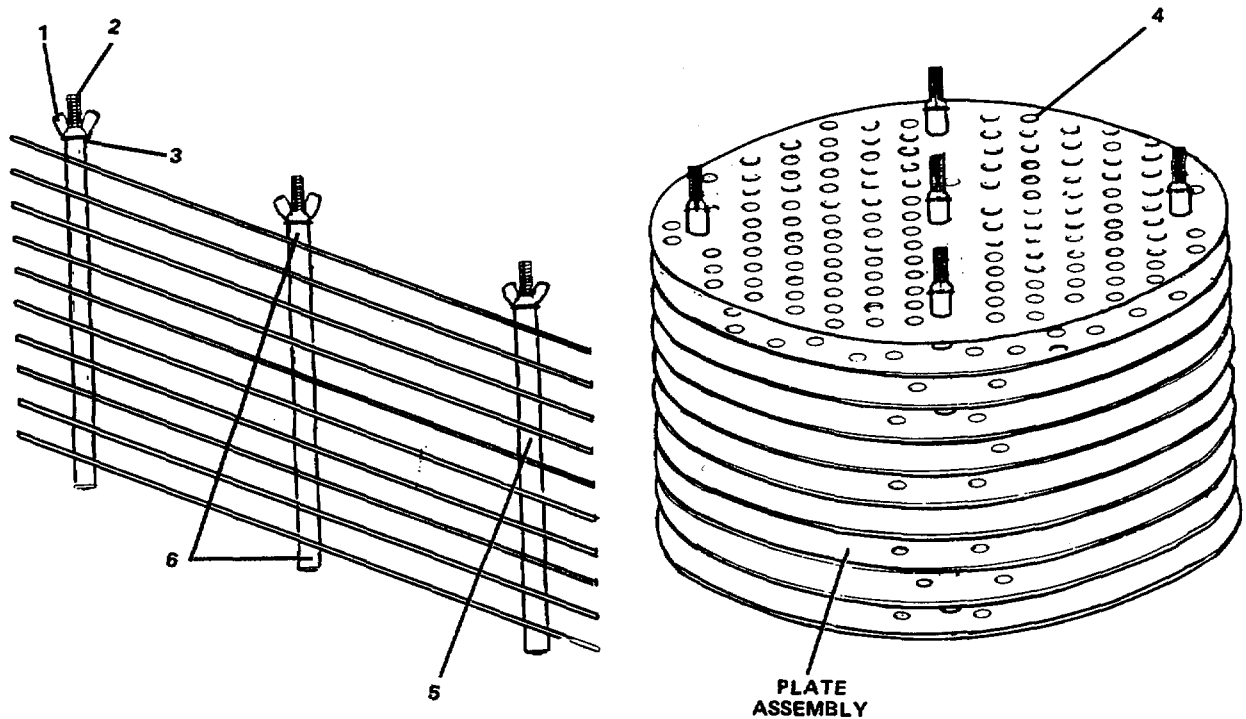

FIGURE 3-23. Plate Assembly.

#### ASSEMBLY

- a. Install five sleeve spacers (6) at bottom of five threaded rod ends (2).
- b. Alternately install ten elliptical plates, one at a time, with five sleeve spacers (5) on threaded rod ends (2).
- c. Install five sleeve spacers (6) on threaded rod ends at top of plate assembly.
- d. Install five flat washers (3) and self-locking wing nuts (1) on five threaded rod ends.

#### REPLACEMENT

- a. Carefully lift and position plate assembly (1) into bottom of vessel (2, Figure 3-22).
- b. Baffles and vessel cover replaced as specified in paragraph 3-25 .

---

**3-27. Replace Vessel Subassembly (Third Stage).(Figure 3-24)**

---

**This task covers:**

**a. Removal,**

**b. Replacement.**

---

**INITIAL SETUP**Tools

Tool kit, general mechanic's,  
5180-00-699-5273

Equipment Condition

Drain vessel (third stage) as specified  
in paragraph 2-29 .

Materials/Parts

Vessel P/N 1334-4

---

**REMOVAL**

- a. Ensure vessel is firmly secured for removal.
- b. Remove four hex plain nuts (3) lockwashers (2) and machine bolts (1) securing mounting skid.
- c. Remove third stage vessel.

**NOTE**

Disconnect piping system from vessel. Plug/cap all fittings and openings.

**REPLACEMENT**

- a. Carefully position third stage vessel on mounting skid with mounting bolt holes aligned.
- b. Install four machine bolts (1), lockwashers (2) and hex plain nuts (3). There are no torque requirements.

**NOTE**

Unplug/cap all fittings and openings. Connect piping system to vessel.

- c. Restore normal operation as specified in paragraph 2-29 .

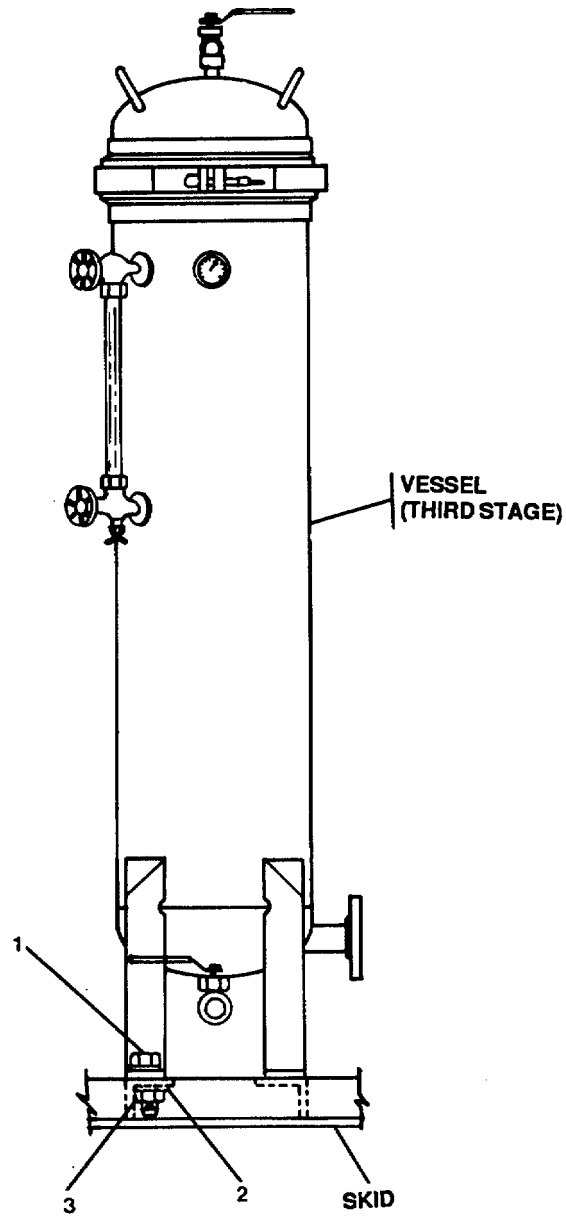

FIGURE 3-24. Vessel Subassembly (Third Stage).

---

**3-28. Repair Vessel Subassembly (Third Stage). (Figure 3-25)**

---

**This task covers:**

- a. Disassembly,                      b. Repair,                      c. Assembly.**
- 

**INITIAL SETUP**Tools

Tool kit, general mechanic's,  
5180-00-699-5273

Materials/Parts

Ball valve P/N VB57, VB62  
Preformed packing P/N GA19

Equipment Condition

Vessel (third stage) removed as  
specified in paragraph 3-27 .  
Vessel cover removed as specified in  
paragraph 2-29 .

---

**DISASSEMBLY**

- a. Disconnect ball valve (2) pipe elbow (4) and pipe nipple (1) from cover.
- b. Disconnect ball valve (2) pipe elbow (4) and pipe nipple (1) from vessel (20).
- c. Separate packing retainer (3) and preformed packing (22) from cover.
- d. Disconnect coupler (13) and remove metal tube (12).
- e. Disconnect pipe elbow (19).
- f. Remove self-locking wing nut (7), packing retainer (6), two preformed packings (8) and cover (5).
- g. Lift coalescer element (9) off support (10) and out of vessel.
- h. Disconnect support (10) by unscrewing support from pipe nipple (11). Remove support from vessel.
- i. Disconnect and lift pipe nipple (11) from vessel.
- j. Disconnect stop check valve (14) and pipe nipple (15).
- k. Disconnect ball valve (17) and pipe nipple (16).
- l. Remove pipe plug (18) from vessel.
- m. Disconnect sight glass (21) from vessel.

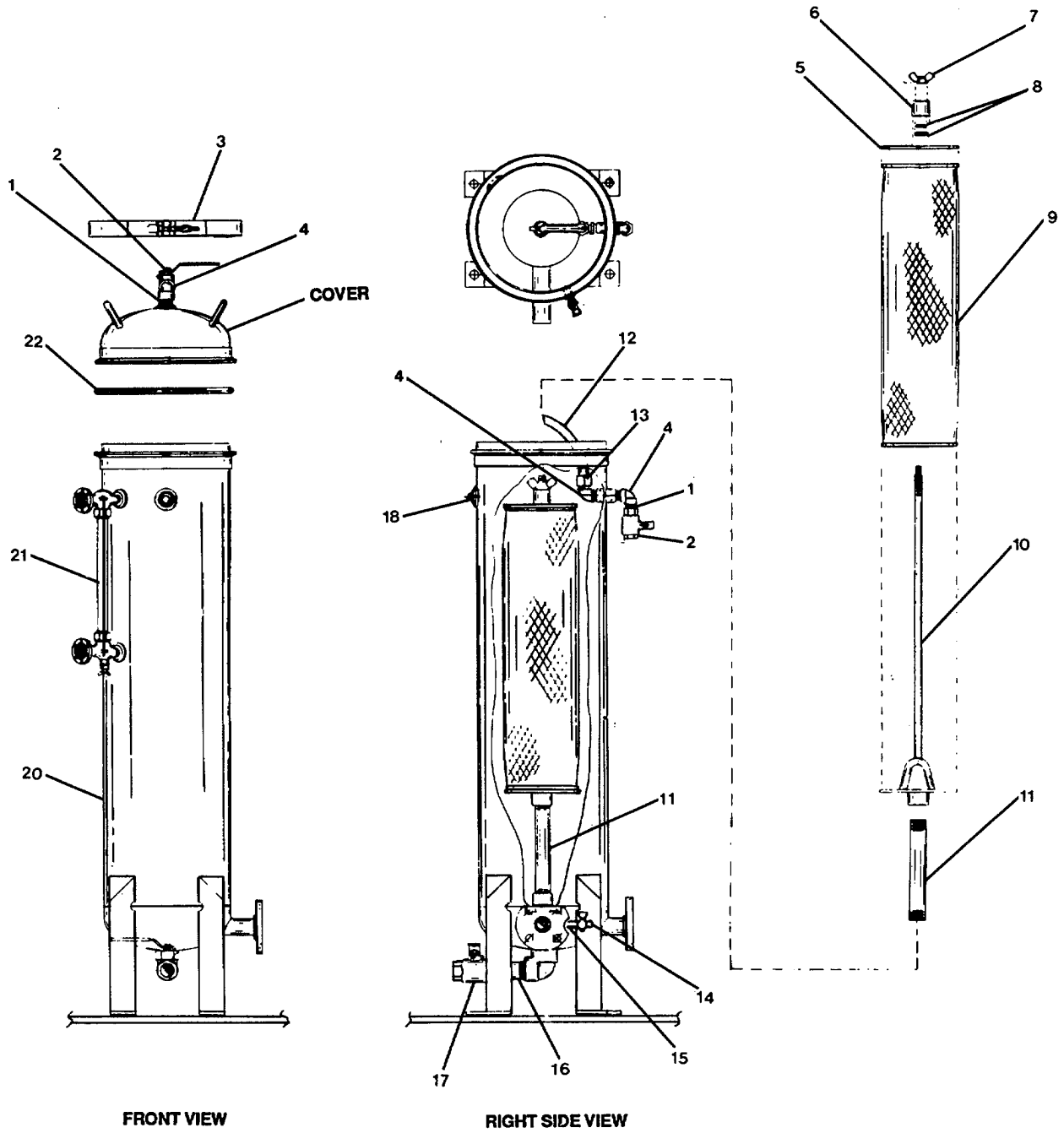

FIGURE 3-25. *Vessel Subassembly (Third Stage).*

## REPAIR

Repair of vessel subassembly (third stage) consists of replacing ball valves (2), (2) and preformed packing (22).

## ASSEMBLY

- a. Connect sight glass (21) to vessel (20).
- b. Install pipe plug (18) on vessel.
- c. Connect pipe nipple (16) and ball valve (17).
- d. Connect pipe nipple (15) and stop check valve (14).
- e. Position and connect pipe nipple (11) to vessel.
- f. Position and connect support (10) by screwing support on pipe nipple (11).
- g. Lower coalescer element (9) on support (10) and into vessel.
- h. Install cover (5), two preformed packings (8), packing retainer (6), and self-locking wing nut (7).
- i. Connect pipe elbow (19).
- j. Position metal tube (12) and connect coupler (13).
- k. Attach preformed packing (22) and packing retainer (3) to cover.
- l. Connect pipe nipple (1), pipe elbow (4), and ball valve (2) to vessel (20).
- m. Connect pipe nipple (1), pipe elbow (4), and ball valve (2) to cover.
- n. Vessel cover replaced as specified in paragraph 2-29 .
- o. Vessel (third stage) replaced as specified in paragraph 3-27 .

**3-29. Replace Vessel Subassembly (Second Stage). (Figure 3-26)**

**This task covers:**

- a. Removal,
- b. Replacement.

**INITIAL SETUP**

Tools

Tool kit, general mechanic's,  
5180-00-699-5273

Equipment Condition

Drain (second stage) vessel as  
specified in para. 2-30 .  
Control module assembly removed  
as specified in para. 2-26 .

Materials/Parts

Vessel subassembly P/N 1332

**REMOVAL**

**NOTE**

Disconnect piping system from vessel. Plug/cap all pipe fittings and openings.

- a. Ensure that vessel is firmly secured for removal.
- b. Remove four hex plain nuts (3), lockwashers (2), and machine bolts (1) securing vessel to mounting skid.
- c. Remove vessel.

**REPLACEMENT**

- a. Carefully position second stage vessel on mounting skid with bolt aligned.
- b. Install four machine bolts (1), lockwashers (2), and hex plain nuts (3) and secure vessel to mounting skid. There are no torque requirements.

**NOTE**

Unplug/cap all pipe fittings and openings. Connect piping system to vessel.

- c. Control module assembly replaced as specified in paragraph 2-26 .
- d. Restore to normal operation as specified in paragraph 2-30 .

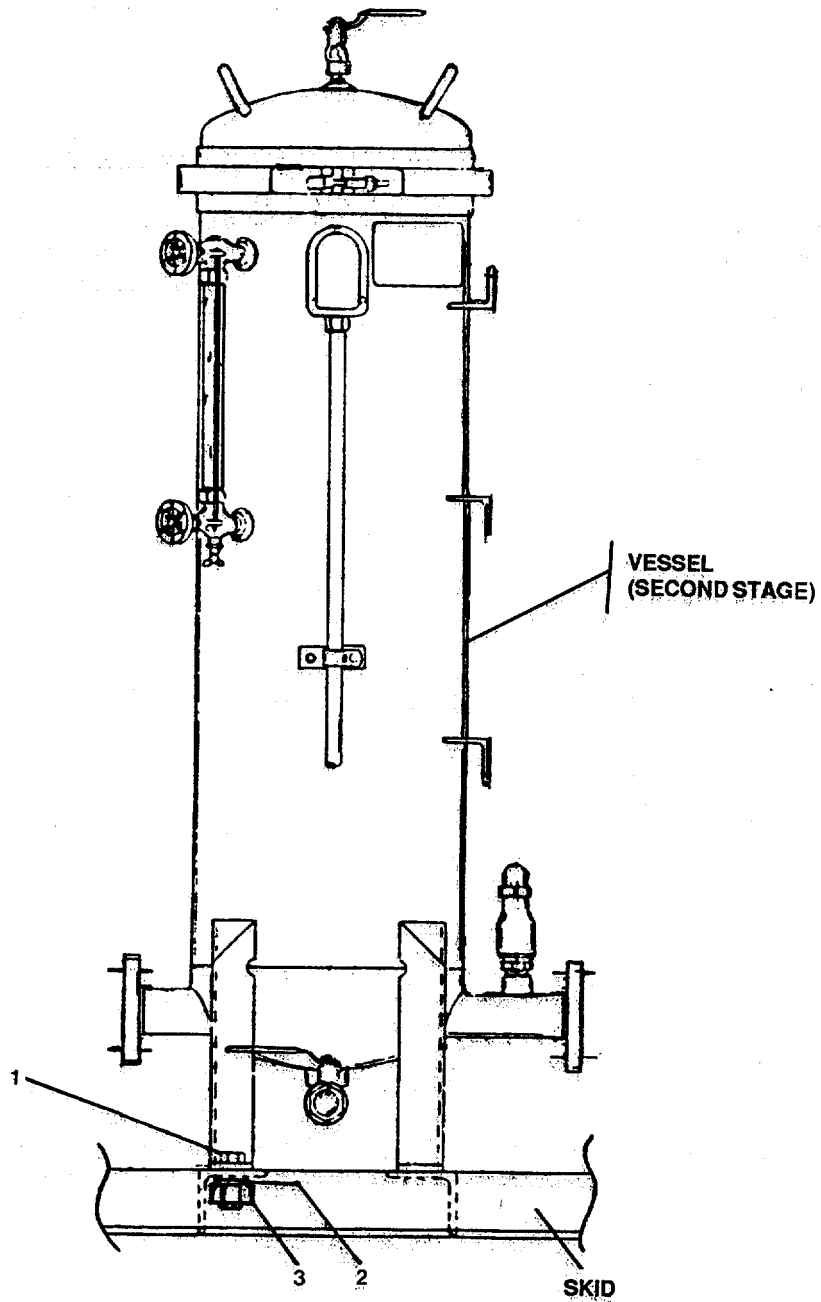

FIGURE 3-26. Vessel Subassembly (Second Stage).



**3-30. Repair Vessel Subassembly (Second Stage). (Figure 3-27)****This task covers:**

- a. Disassembly,                      b. Repair,                      c. Assembly.

**INITIAL SETUP**Tools

Tool kit, general mechanic's,  
5180-00-699-5273

Materials/Parts

Ball valve P/N VB62, VB57  
Relief valve P/N VD33  
Level switch P/N SX77

Equipment Condition

Vessel (second stage) removed as  
specified in para. 3-29 .  
Vessel cover removed as specified  
in para. 2-30 .

**DISASSEMBLY**

- a. Disconnect ball valve (3), pipe elbow (2), and pipe nipple (1) from vessel cover.
- b. Separate packing retainer (4) and preformed packing (24) from vessel cover.
- c. Disconnect sight glass (23).
- d. Disconnect relief valve (21).
- e. Disconnect stop check valve (6), pipe nipple (7), and pipe elbow (5).
- f. Disconnect and remove liquid transmitter (20).
- g. Disconnect solenoid valve (16) and pipe nipple (17).
- h. Disconnect ball valve (19) and pipe nipple (18).

**NOTE**

Filter elements are removed as specified in paragraph 2-38 .

- i. Remove self-locking nut (11), packing retainer (12) and preformed packing (10).
- j. Lift cover (9) and fluid filter element (13) off of support (14).
- k. Lift ring support (8) and fluid filter element (13) off of support (14).

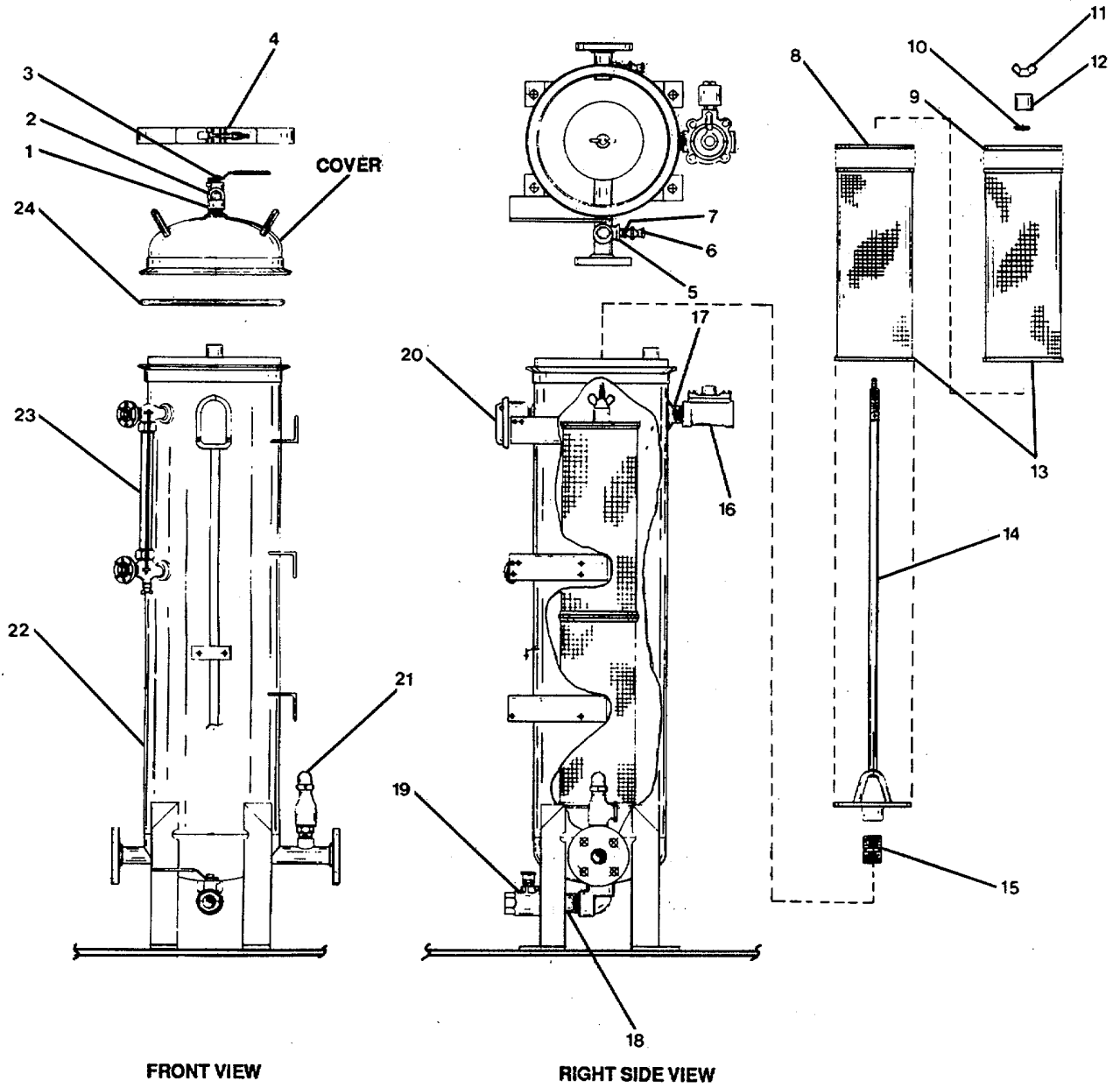

FIGURE 3-27. *Vessel Subassembly (Second Stage).*

- l. Disconnect support (14) by unscrewing support from pipe nipple (15). Lift support out of vessel.
- m. Disconnect pipe nipple (15) at bottom of vessel. Remove pipe nipple.

## REPAIR

Repair of vessel subassembly (second stage) consists of replacing ball valve (3), (19), relief valve (21).

## ASSEMBLY

- a. Connect pipe nipple (15) at bottom of vessel (22).
- b. Connect support (14) by screwing support to pipe nipple (15).

### NOTE

Filter elements are replaced as specified in paragraph 2-30 .

- c. Lower fluid filter element (13) and support ring (8) on support (14).
- d. Lower fluid filter element (13) and cover (9) on support (14).
- e. Install preformed packing (10) packing retainer (12) and self-locking nut (11).
- f. Connect pipe nipple (18) and ball valve (19).
- g. Connect pipe nipple (17) and solenoid valve (16).
- h. Install and connect liquid transmitter (20).
- i. Connect pipe elbow (5), pipe nipple (7), and stop check valve (6).
- j. Connect relief valve (21).
- k. Connect sight glass (23).
- l. Attach preformed packing (24) and packing retainer (4) on vessel cover.
- m. Connect pipe nipple (1), pipe elbow (2), and ball valve (3).
- n. Vessel cover replaced as specified in paragraph 2-30 .
- o. Vessel (second stage) replaced as specified in paragraph 3-29 .

---

**3-31. Replace Oil Pump/Motor Assembly. (Figure 3-28)**

---

**This task covers:****a. Removal,****b. Replacement.**

---

**INITIAL SETUP**Tools

Tool kit, general mechanic's,  
5180-00-699-5273

Equipment Condition

System drained, refer to paragraphs  
2-29 and 2-30 .

Material/Parts

Oil pump/motor assembly  
P/N 1334-2  
Motorized pump P/N 33260  
Warning tags, Item 1, Appendix C

---

**REMOVAL**

- a. Tag and disconnect electrical leads from junction box (4) on motor.
- b. Disconnect system piping from pipe nipple (1).
- c. Disconnect pipe nipple (1) from reducing elbow (2).
- d. Disconnect reducing elbow (2) and pipe nipple (12) at union (13).
- e. Disconnect pipe fittings (11) from pump inlet.
- f. Disconnect system piping at union (5).
- g. Disconnect pipe fittings (6) from pump outlet.
- h. Disconnect swage nipple (3) from pump outlet.
- i. Remove four hex plain nuts (9), lockwashers (8), and machine bolts (7) securing pump/motor assembly to skid base.
- j. Remove oil pump/motor assembly (10).

**REPLACEMENT**

- a. Position oil pump/motor assembly (10) on skid base with bolt holes aligned.
- b. Install four machine bolts (7), lockwashers (8), and hex plain nuts (9) and secure pump/motor assembly to skid.

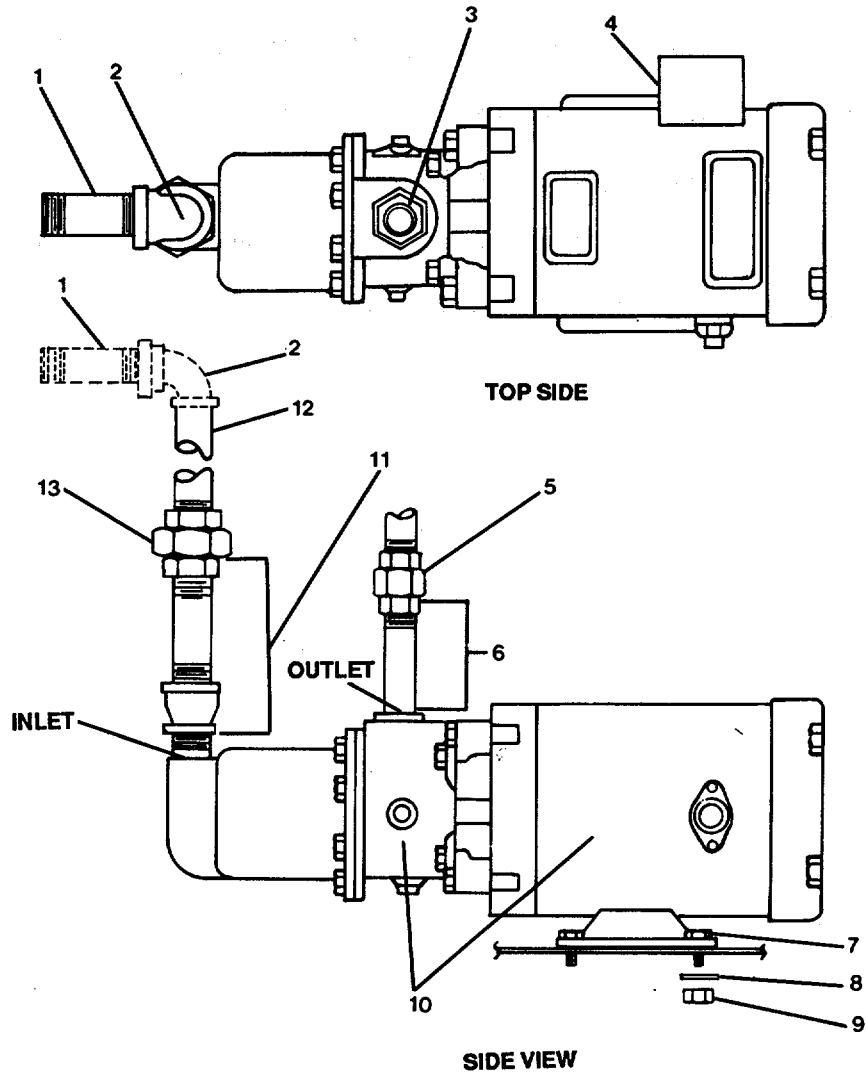

FIGURE 3-28. *Oil Pump/Motor Assembly.*

- c. Connect swage nipple (3) on pump outlet.
- d. Connect pipe fittings (6) to pump outlet.
- e. Connect system piping at union (5).
- f. Connect pipe fittings (11) to pump inlet.
- g. Connect pipe nipple (12) and reducing elbow (2) at union (13).
- h. Connect pipe nipple (1) to reducing elbow (2).
- i. Connect system piping to pipe nipple (1).
- j. Connect electrical leads to motor at junction box (4). Remove tags.
- k. Restore normal operation (paragraph 2-30).

---

**3-32. Replace Water Pump/Motor Assembly. (Figure 3-29)**

---

**This task covers:****a. Removal,****b. Replacement.**

---

**INITIAL SETUP**Tools

Tool kit, general mechanic's,  
5180-00-699-5273

Equipment Condition

System drained - refer to paragraphs  
2-29 and 2-30 .

Materials/Parts

Water pump/motor assembly  
P/N 1334-1  
Warning tags, Item 1, Appendix C

**REMOVAL**

- a. Tag and disconnect electrical leads at junction box (1) on motor.
- b. Disconnect flange (5) from pipe nipple (6).
- c. Disconnect pipe nipple (6), check valve (4), and pipe nipple (3) from pump inlet.
- d. Disconnect flange (8) and pipe nipple (7) from pump outlet.
- e. Remove four hex plain nuts (9), lockwashers (10), and machine bolts (11) securing pump/motor assembly to mounting skid.
- f. Remove water pump/motor assembly (2).

**REPLACEMENT**

- a. Position water pump/motor assembly (2) on mounting skid with mounting bolt holes aligned.
- b. Install four machine bolts (11), lockwashers (10), and hex plain nuts (9) and secure pump/motor assembly to mounting skid.
- c. Connect pipe nipple (7) and flange (8) to pump outlet.
- d. Connect pipe nipple (3) check valve (4) and pipe nipple (6) to pump inlet.
- e. Connect flange (5) to pipe nipple (6).
- f. Connect electrical leads at junction box (1) on motor. Remove tags.
- g. Restore to normal operation, paragraph 2-30 .

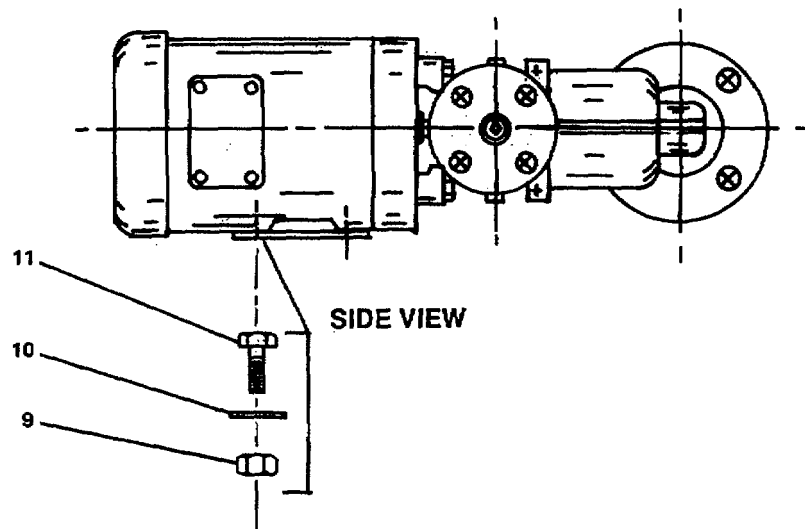
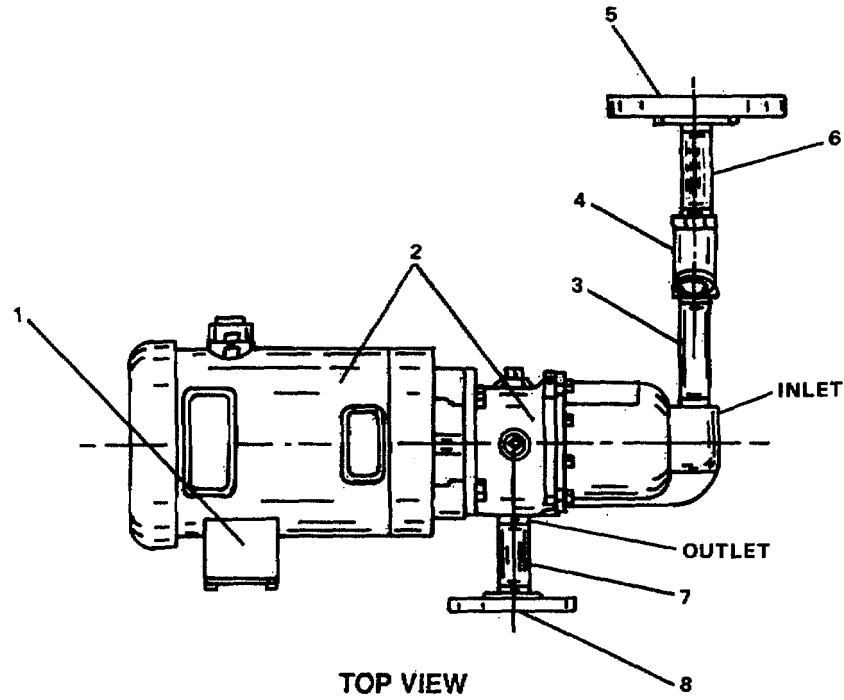

FIGURE 3-29. *Water Pump/Motor Assembly.*



---

**3-33. Replace Sensing Module Assembly. (Figure 3-30)**

---

**This task covers:****a. Removal,****b. Replacement.**

---

**INITIAL SETUP**Tools

Tool kit, general mechanic's,  
5180-00-699-5273

Equipment Condition

Drain third stage vessel as specified  
in paragraph 2-29 .

Materials/Parts

Sensing module assembly  
P/N 770  
Warning tags, Item 1, Appendix C

---

**REMOVAL****a. Sensing Module Assembly.**

- (1) Open sensing module cleanout valve (4).
- (2) Open sensing module drain valve (10).
- (3) Remove cover screw from junction box (1). Remove cover.
- (4) Tag and disconnect sensor wires to sensor manifold (15).
- (5) Disconnect cable connector (14) and separate sensor cable (13) from junction box.
- (6) Remove junction box from sensor manifold.
- (7) Disconnect inlet pipe connection from sensor manifold at union (8).
- (8) Disconnect outlet pipe connection from sensor manifold at union (12).
- (9) Remove sensor manifold and piping assembly.

**b. Pipe Connections.**

- (1) Position sensor manifold and piping assembly on a clean, flat surface.
- (2) Disconnect pipe nipple (7) with union coupler pipe elbow (6) and pipe nipple (5) from pipe tee (3).

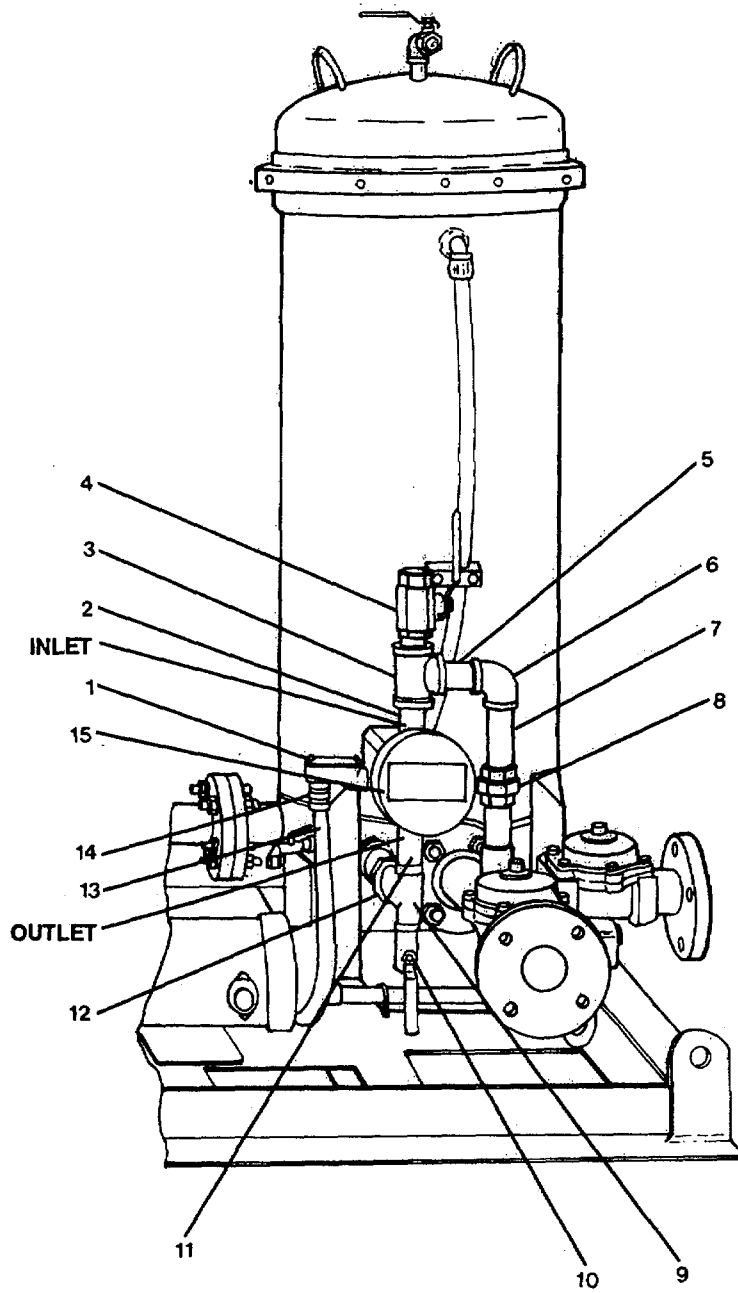

FIGURE 3-30. Sensing Module Assembly.

- (3) Disconnect cleanout valve (4), pipe tee (3), and pipe nipple (2) from inlet port on sensor manifold (15).
- (4) Disconnect drain valve (10) from pipe tee (9)
- (5) Disconnect pipe tee (9) fitting and pipe nipple (11) from outlet port on sensor manifold.

## REPLACEMENT

### a. Pipe Connections.

- (1) Position sensor manifold (15), on a clean flat surface.
- (2) Connect pipe nipple (11) and pipe tee (9) fitting on outlet port to sensor manifold. Ensure that pipe tee fitting is correctly positioned.
- (3) Connect drain valve (10) to pipe tee (9).
- (4) Connect pipe nipple (2), pipe tee (3), and cleanout valve (4) to inlet port on sensor manifold. Ensure that pipe tee (3) is properly positioned.
- (5) Connect pipe nipple (5), pipe elbow (6), and pipe nipple (7) with union coupler to pipe tee (3).

### b. Sensing Module Assembly.

- (1) Position sensing module assembly over union couplers (12 and 8).
- (2) Connect outlet pipe connections to sensor manifold at union (12).
- (3) Connect inlet pipe connection to sensor manifold at union (8).
- (4) Remove cover screw from junction box (1). Remove cover.
- (5) Position junction box on sensor manifold.
- (6) Pull tagged sensor wiring through opening and into junction box.
- (7) Install junction box on sensor manifold.
- (8) Pull tagged wire leads up through opening on junction box.
- (9) Attach sensor cable (13) to junction box (1) with cable connection (14).
- (10) Connect sensor wire leads. Remove tags.
- (11) Install cover on junction box.
- (12) Close sensing module drain valve (10).
- (13) Close sensing module cleanout valve (4).
- (14) Restore normal operation as specified in paragraph 2-29.

<b>MAINTENANCE OF SOUND POWERED PHONE SYSTEM</b>
--

---

### 3-34. Repair Sound Powered Telephone SER (MOD)-19. (Figure 3-31)

---

**This task covers:**

- a. Disassembly,                      b. Repair,                      c. Assembly.
- 

#### INITIAL SETUP

Tools

Tool kit, electrician's,  
5180-00-391-1087

Equipment Condition

Sound powered telephone removed,  
para. 2-31 .

Materials/Parts

Gasket P/N 50-19A  
Hand ringing generator P/N 22  
Manual control handle P/N 24  
Electromagnetic relay P/N 31  
Electrical bell P/N ICB2S4EXP  
Warning tags, Item 1, Appendix C

---

#### DISASSEMBLY

- a. Remove self-locking screws (1).
- b. Remove telephone cover (3) and gasket (4).
- c. Tag and disconnect electrical leads and remove telephone selector switch (2).
- d. Remove self-locking screw (13).
- e. Remove headset bracket (14), bracket spring (15), and cotter pin (16).
- f. Tag and disconnect electrical leads and remove telephone box (7).
- g. Remove drive screw (17).
- h. Remove hand ringing generator (9) and manual control handle (8).
- i. Remove electromagnetic relay (18).
- j. Remove drive screw (20, 21) and terminal board (6).
- k. Remove drive screw (11) and terminal board (12).
- l. Remove telephone cord guard (10).

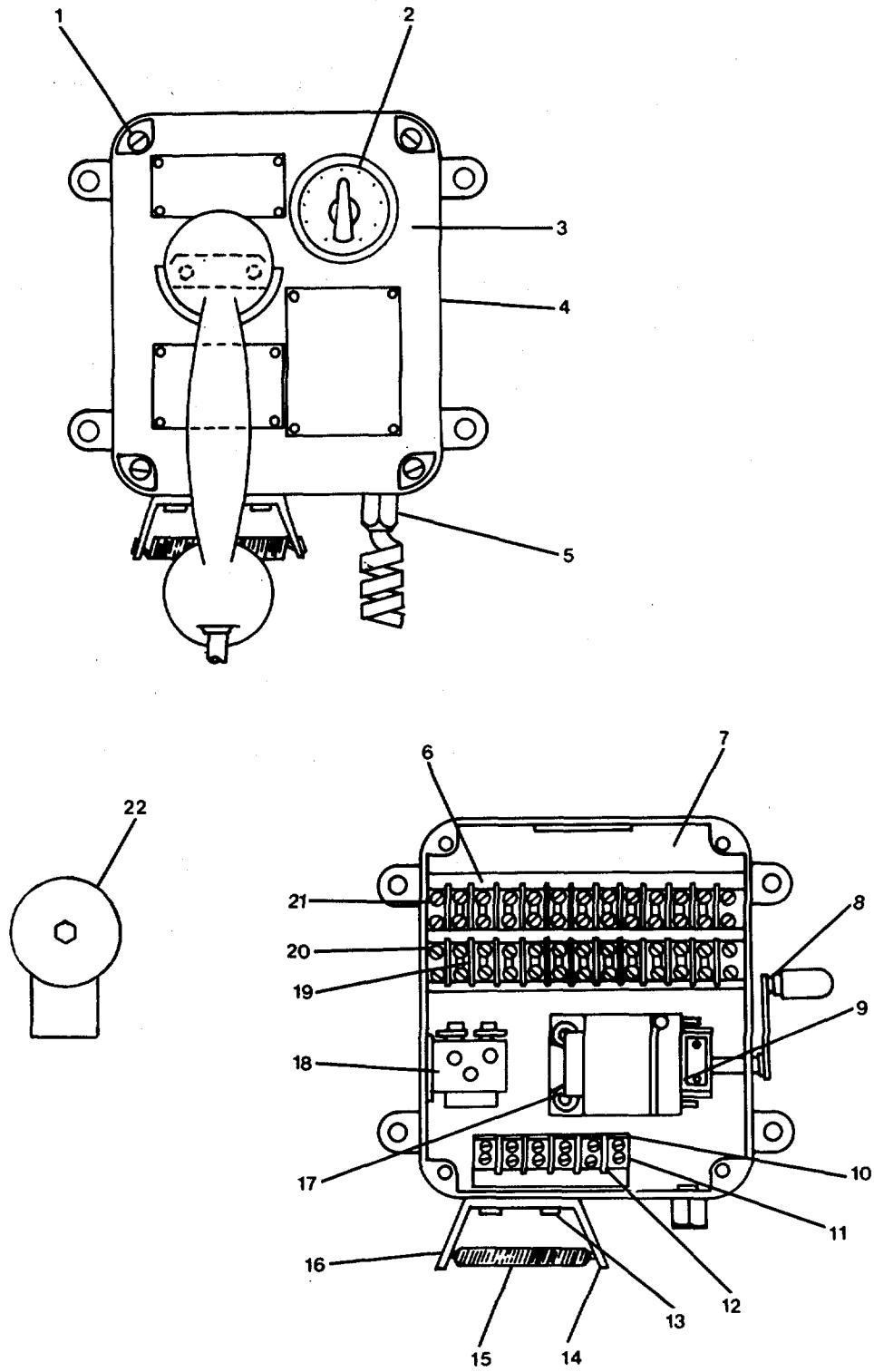

FIGURE 3-31. *Sound Powered Telephone SER (MOD)-19.*

- m. Tag and disconnect electrical leads and remove electrical bell (22).

## REPAIR

Repair at this level of maintenance is by replacement of gasket (4), hand ringing generator (9), manual control handle (8), electromagnetic relay (18), and electrical bell (22).

## ASSEMBLY

- a. Install electrical bell (22). Remove tags and connect electrical leads.
- b. Install telephone cord guard (10).
- c. Install terminal board (12) and drive screw (11).
- d. Install terminal board (6) and drive screw (20, 21).
- e. Install electromagnetic relay (18).
- f. Install manual control handle (8) and hand ringing generator (9).
- g. Install drive screw (17).
- h. Install telephone box (7). Remove tags and connect electrical leads.
- i. Install cotter pin (16)', bracket spring (15), and headset bracket (14).
- j. Install self-locking screw (13).
- k. Remove tags, connect electrical leads and install telephone selector switch (2).
- l. Install gasket (4) and telephone cover (3).
- m. Install self-locking screws (1).
- n. Refer to paragraph 2-31 for replacement of sound powered telephone.

---

**3-35. REPAIR SOUND POWERED TELEPHONE SELR (MOD)-19. (Figure 3-32)**

---

This task covers:

a. Disassembly

b. Repair

c. Assembly

---

**INITIAL SETUP**Tools

Tool kit, electrician's,  
5180-00-391-1087

Equipment Condition

Sound powered telephone removed,  
para. 2-31 .

Materials/Parts

Gasket P/N 450-19B  
Pilot light assembly P/N 41  
Hook switch P/N 44  
Electromagnetic relay P/N 32A  
Hand ringing generator P/N 22  
Manual control handle P/N 24  
Electrical bell P/N ICB2S4EXP  
Electrical horn P/N IC/H1S4  
Warning tags, Item 1, Appendix C

---

**DISASSEMBLY**

- a. Remove drive screw (1).
- b. Remove access cover (3) and gasket (10) from telephone housing (9).
- c. Tag and disconnect electrical leads. Remove telephone selector switch (2).
- d. Remove drive screw (8).
- e. Remove headset bracket (5), headset retaining spring (6), and cotter pin (7).
- f. Tag and disconnect electrical leads. Remove pilot light assembly (19), lens (20), and incandescent lamp (21).
- g. Remove hook switch (22).
- h. Remove self-locking screw (14) and electromagnetic relay (25).
- i. Remove self-locking screw (15).
- j. Remove hand ringing generator (23) and manual control handle (24).

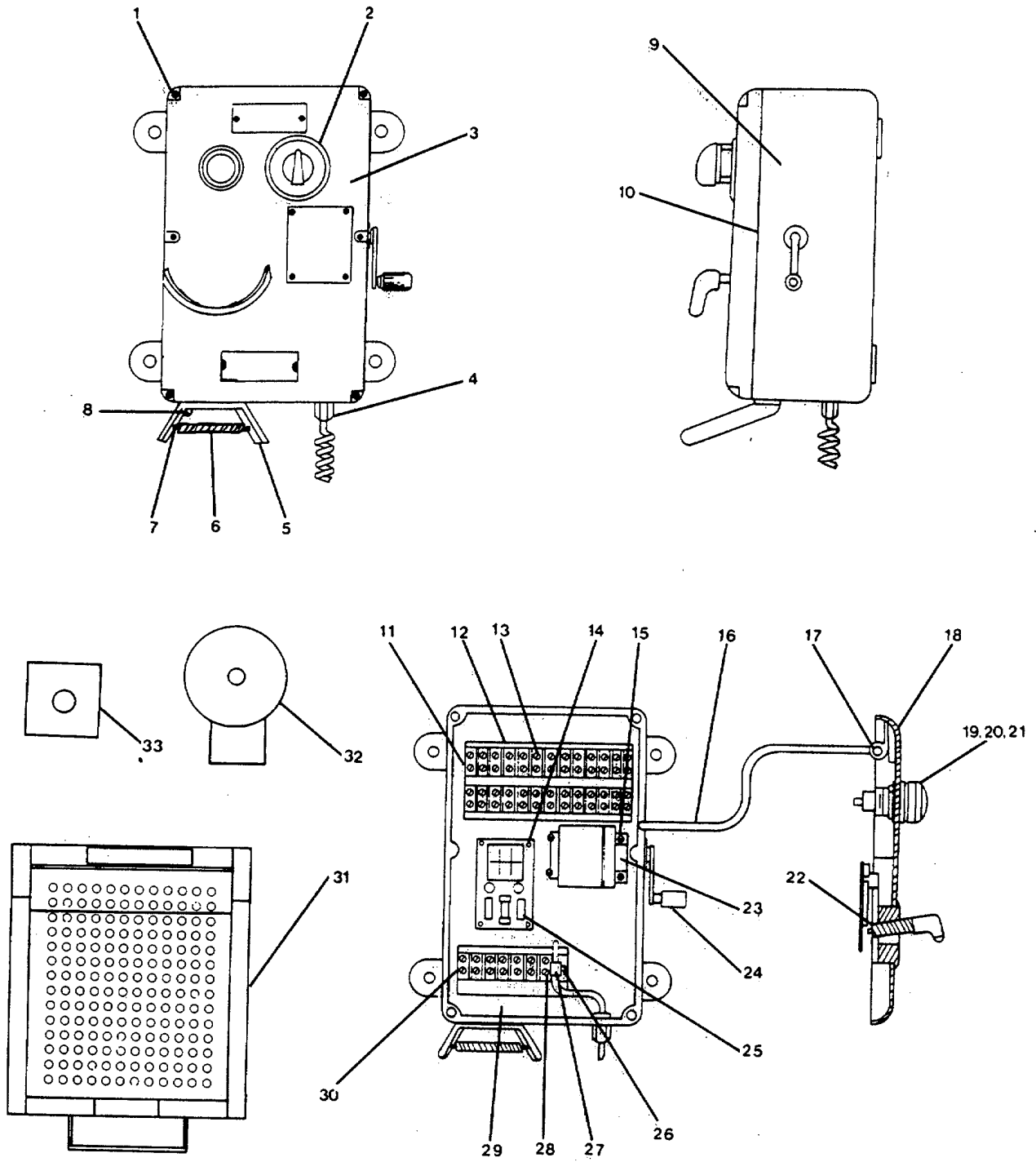

FIGURE 3-32. *Sound Powered Telephone SELR (MOD)-19.*



- k. Tag and disconnect electrical leads. Remove drive screw (28), identification plate (29) and terminal board (30).
- l. Tag and disconnect electrical leads. Remove drive screw (11), identification plate (12), and terminal board (13).
- m. Remove cable strap (27) and electrical cable (16).
- n. Remove telephone cord guard (4).
- o. Remove acoustic-booth (31).
- p. Tag and disconnect electrical leads. Remove electrical bell (32).
- q. Tag and disconnect electrical leads. Remove electrical horn (33).

## REPAIR

Repair at this level of maintenance is by replacement of gasket (10), pilot light assembly (19), hook switch (22), electromagnetic relay (25), hand ringing generator (23), manual control handle (24), electrical bell (32), and electrical horn (33).

## ASSEMBLY

- a. Install electrical horn (33). Remove tags and connect electrical leads.
- b. Install electrical bell (32). Remove tags and connect electrical leads.
- c. Install acoustic-booth (31).
- d. Install telephone cable guard (4).
- e. Install electrical cable (16) and cable strap (27).
- f. Install terminal board (13), identification plate (12), and drive screw (11). Remove tags and connect electrical leads.
- g. Install terminal board (30), identification plate (29), and drive screw (28). Remove tags and connect electrical leads.
- h. Install manual control handle (24) and hand ringing generator (23).
- i. Install self-locking screw (15).
- j. Install electromagnetic relay (25) and self-locking screw (14).
- k. Install hook switch (22).
- l. Install incandescent lamp (21), lens (20), and pilot light assembly (19). Remove tags and connect electrical leads.

- m. Install cotter pin (7), headset retaining spring (6), and headset bracket (5).
- n. Install drive screw (8).
- o. Install telephone selector switch (2). Remove tags and connect electrical leads.
- p. Install gasket (10) and access cover (3) into telephone housing (9).
- q. Install drive screw (1).
- r. Refer to paragraph 2-31 for replacement of sound powered telephone.

---

**3-36. Repair Sound Powered Telephone SER (MOD)-8. (Figure 3-33)**

---

**This task covers:****a. Disassembly****b. Repair****c. Assembly**

---

**INITIAL SETUP:**ToolsTool kit, electrician's,  
5180-00-391-1087Equipment ConditionSound powered telephone removed,  
para. 2-31 .Materials/PartsGasket P/N 50-19A  
Hand ringing generator P/N 22  
Manual control handle P/N 24  
Electromagnetic relay P/N 31  
Electrical bell P/N ICB2S4EXP  
Warning tags, Item 1, Appendix C**DISASSEMBLY**

- a. Remove self-locking screw (1).
- b. Remove telephone cover (2) and gasket (4).
- c. Tag and disconnect electrical leads. Remove telephone selector switch (3).
- d. Remove self-locking screw (12).
- e. Remove headset bracket (11), bracket spring (13), and cotter pin (10).
- f. Tag and disconnect electrical leads. Remove telephone box (6).
- g. Remove drive screw (14).
- h. Remove hand ringing generator (9) and manual control handle (7).
- i. Remove electromagnetic relay (15).
- j. Remove drive screws (17, 18).
- k. Remove identification plate (19) and terminal board (16).
1. Remove telephone cord guard (5).
- m. Tag and disconnect electrical leads. Remove electrical bell (8).

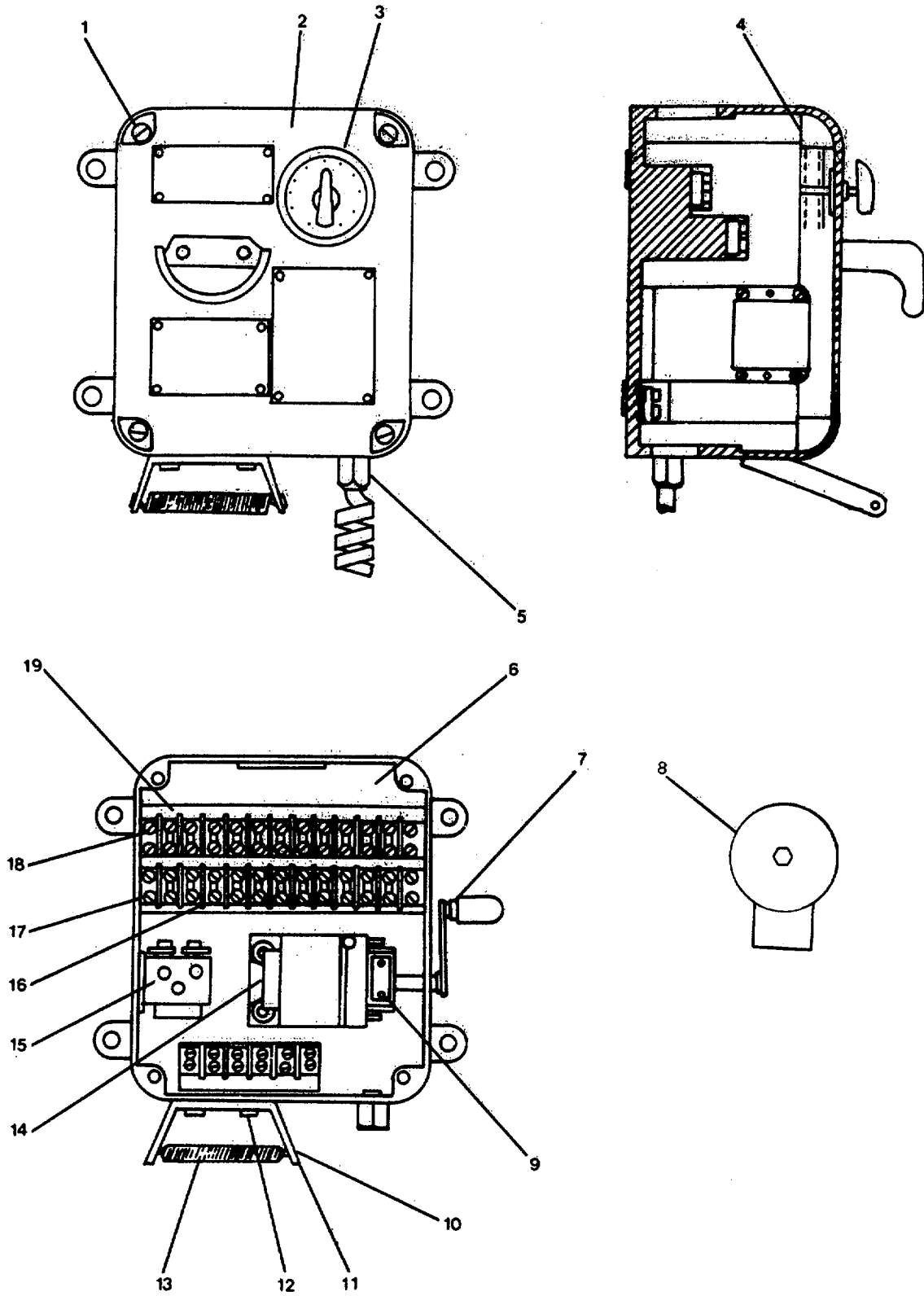

FIGURE 3-33. *Sound Powered Telephone SER (MOD)-8.*

**REPAIR**

Repair at this level of maintenance is by replacement of gasket (4), hand ringing generator (9), manual control handle (7), electromagnetic generator (15), and electrical bell (8).

**ASSEMBLY**

- a. Install electrical bell (8). Remove tags and connect electrical leads.
- b. Install telephone cord guard (5).
- c. Install terminal board (16) and identification plate (19).
- d. Install drive screws (17, 18).
- e. Install electromagnetic relay (15).
- f. Install manual control handle (7) and hand ringing generator (9).
- g. Install drive screw (14).
- h. Install telephone box (6). Remove tags and connect electrical leads.
- i. Install cotter pin (10), bracket spring (13), and headset bracket (11).
- j. Install self-locking screw (12).
- k. Install telephone selector switch (3). Remove tags and connect electrical leads.
- l. Install gasket (4) and telephone cover (2).
- m. Install self-locking screw (1).
- n. Refer to paragraph 2-31 for replacement of sound powered telephone.

---

**3-37. Repair Sound Powered Telephone SER (MOD)-8. (Figure 3-34)**

---

**This task covers:****a. Disassembly****b. Repair****c. Assembly**

---

**INITIAL SETUP:**Tools

Tool kit, electrician's,  
5180-00-391-1087

Equipment Condition

Sound powered telephone removed,  
para. 2-31 .

Materials/Parts

Gasket P/N 50-19B  
Pilot light assembly P/N 41  
Hook switch P/N 44  
Electromagnetic relay P/N 32A  
Hand ringing generator P/N 22  
Manual control handle P/N 24  
Warning tags, Item 1, Appendix C

**DISASSEMBLY**

- a. Remove drive screw (1).
- b. Remove access cover (3) and gasket (10) from telephone housing (9).
- c. Tag and disconnect electrical leads. Remove telephone selector switch (2).
- d. Remove drive screw (8).
- e. Remove handset bracket (5), bracket spring (6), and cotter pin (7).
- f. Tag and disconnect electrical leads. Remove pilot light assembly (19), lens (20) and incandescent lamp (21).
- g. Remove hook switch (22).
- h. Remove self-locking screw (14) and electromagnetic relay (25).
- i. Remove self-lock screw (15).
- j. Remove hand ringing generator (23) and manual control handle (24).
- k. Remove drive screws (11, 28).

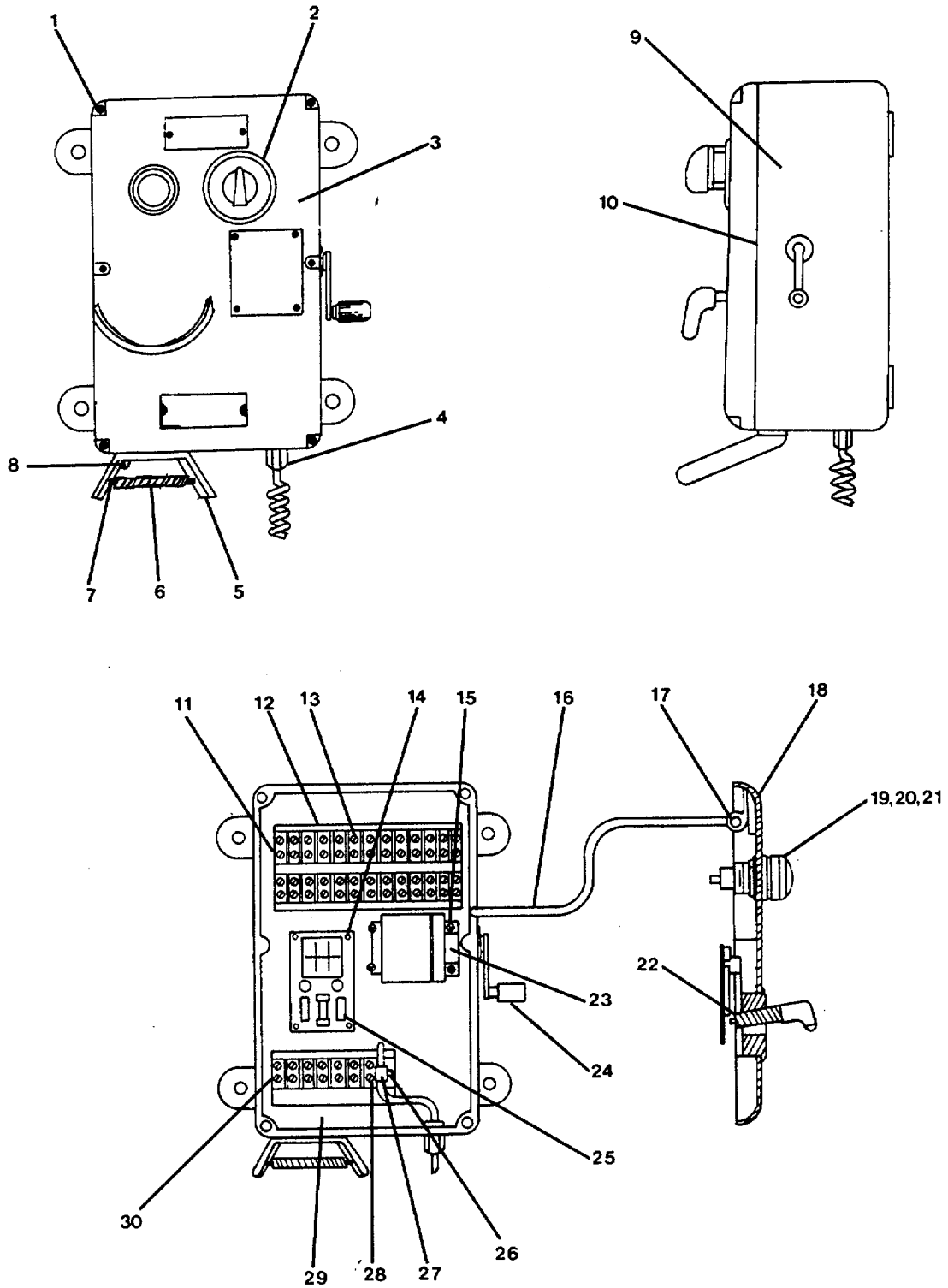

FIGURE 3-34. Sound Powered Telephone SELR (MOD)-8.

- l. Tag and disconnect electrical leads. Remove identification plate (29) and terminal board (30).
- m. Tag and disconnect electrical leads. Remove identification plate (12) and terminal board (13).
- n. Remove cable strap (27) and electrical cable (16).
- o. Remove telephone cord guard (4).

## REPAIR

Repair at this level of maintenance is by replacement of gasket (10), pilot light assembly (19), hook switch (22), electromagnetic relay (25), hand ringing generator (23), manual control handle (24).

## ASSEMBLY

- a. Install telephone cord guard (4).
- b. Install electrical cable (16) and cable strap (27).
- c. Install identification plate (12) and terminal board (13). Remove tags and connect electrical leads.
- d. Install identification plate (29) and terminal board (30). Remove tags and connect electrical leads.
- e. Install drive screws (11, 28).
- f. Install manual control handle (24) and hand ringing generator (23).
- g. Install self-locking screw (15).
- h. Install electromagnetic relay (25) and self-locking screw (14).
- i. Install hook switch (22).
- j. Install incandescent lamp (21), lens (20), and pilot light assembly (19). Remove tags and connect electrical leads.
- k. Install cotter pin (7), bracket spring (6), and handset bracket (5).
- l. Install drive screw (8).
- m. Install telephone selector switch (2). Remove tags and connect electrical leads.
- n. Install gasket (10) and access cover (3) into telephone housing (9).
- o. Install drive screw (1).
- p. Refer to paragraph 2-31 for replacement of sound powered telephone.



---

**3-38. Repair Sound Powered Telephone MWT-R-19. (Figure 3-35)**

---

**This task covers:****a. Disassembly****b. Repair****c. Assembly**

---

**INITIAL SETUP:**ToolsTool kit, electrician's,  
5180-00-391-1087Equipment ConditionSound powered telephone removed,  
para. 2-31 .Materials/PartsGasket P/N 50-56  
Hand ringing generator P/N 22  
Manual control handle P/N 25  
Electromagnetic relay P/N 31  
Electrical bell P/N ICB2S4EXP  
Warning tags, Item 1, Appendix C

---

**DISASSEMBLY**

- a. Loosen t-handle (3) and open cover (1) on handset box (2).
- b. Remove self-locking screw (4), handle guide (5), and t-handle (3).
- c. Remove pivot rod retainer (6) and pivot rod (7).
- d. Remove self-locking screw (10) and open mounting plate (13). Remove gasket (15).
- e. Tag and disconnect electrical leads. Remove telephone selector switch (11).
- f. Remove self-locking screw (21).
- g. Remove hand ringing generator (12) and manual control handle (22).
- h. Remove electromagnetic relay (23).
- i. Remove drive screw (16).
- j. Tag and disconnect electrical leads. Remove terminal board (17).
- k. Remove identification plates (18, 19).
- l. Remove self-locking screw (14) and handset bracket (9).

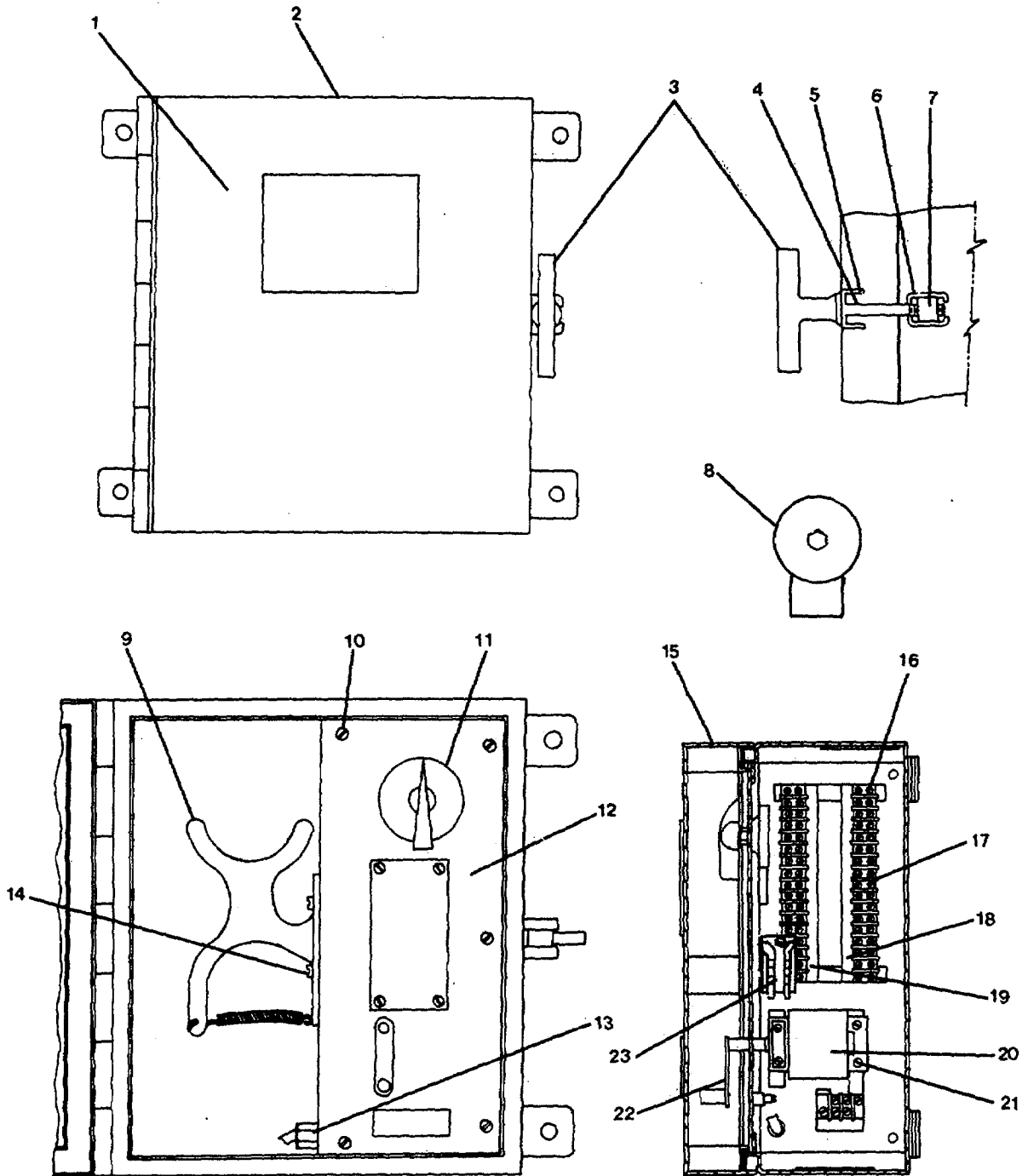

FIGURE 3-35. *Sound Powered Telephone MWT-R-19.*

- m. Remove telephone cord guard (13).
- n. Tag and disconnect electrical leads. Remove electrical bell (8).

## REPAIR

Repair at this level of maintenance is by replacement of gasket (15), hand ringing generator (12), manual control handle (22), electromagnetic relay (23), and electrical bell (8).

## ASSEMBLY

- a. Install electrical bell (8). Remove tags and connect electrical leads.
- b. Install telephone cord guard (13).
- c. Install handset bracket (9) and self-locking screw (14).
- d. Install identification plates (18, 19).
- e. Install terminal board (17). Remove tags and connect electrical leads.
- f. Install drive screw (16).
- g. Install electromagnetic relay (23).
- h. Install manual control handle (22) and hand ringing generator (12).
- i. Install self-locking screw (21).
- j. Install telephone selector switch (11). Remove tags and connect electrical leads.
- k. Install gasket (15). Close mounting plate (12) and install self-locking screw (10).
- l. Install pivot rod (7) and pivot rod retainer (6).
- m. Install t-handle (3), handle guide (5), and self-locking screw (4).
- n. Close cover (1) on handset box (2), and secure t-handle (3).
- o. Refer to paragraph 2-31 for replacement of sound powered telephone.

**3-39. Repair Sound Powered Telephone MWT-R-8. (Figure 3-36)**

This task covers:

- a. Disassembly                      b. Repair                      c. Assembly

**INITIAL SETUP:**

LOCATION	ITEM	ACTION	REMARK
<u>Tools</u>			<u>Equipment Condition</u>
	Tool kit, electrician's, 5180-00-391-1087		Sound powered telephone removed, para. 2-31 .
	Materials/Parts		
	Gasket P/N 50-56 Hand ringing generator P/N 22 Electromagnetic relay P/N 31 Electrical bell P/N ICB2S4EXP Warning tags, Item 1, Appendix C		

**DISASSEMBLY**

- a. Loosen t-handle (3) and open cover (1) on handset box (2).
- b. Remove self-locking screw (4), handle guide (5), and t-handle (3).
- c. Remove pivot rod retainer (6) and pivot rod (7).
- d. Remove self-locking screw (10) and open mounting plate (13). Remove gasket (15).
- e. Tag and disconnect electrical leads. Remove telephone selector switch (11).
- f. Remove self-locking screw (21).
- g. Remove hand ringing generator (12) and manual control handle (22).
- h. Remove electromagnetic relay (23).
- i. Remove drive screw (16).
- j. Tag and disconnect electrical leads. Remove terminal board (17).
- k. Remove identification plates (18, 19).
- l. Remove self-locking screw (14) and handset bracket (9).

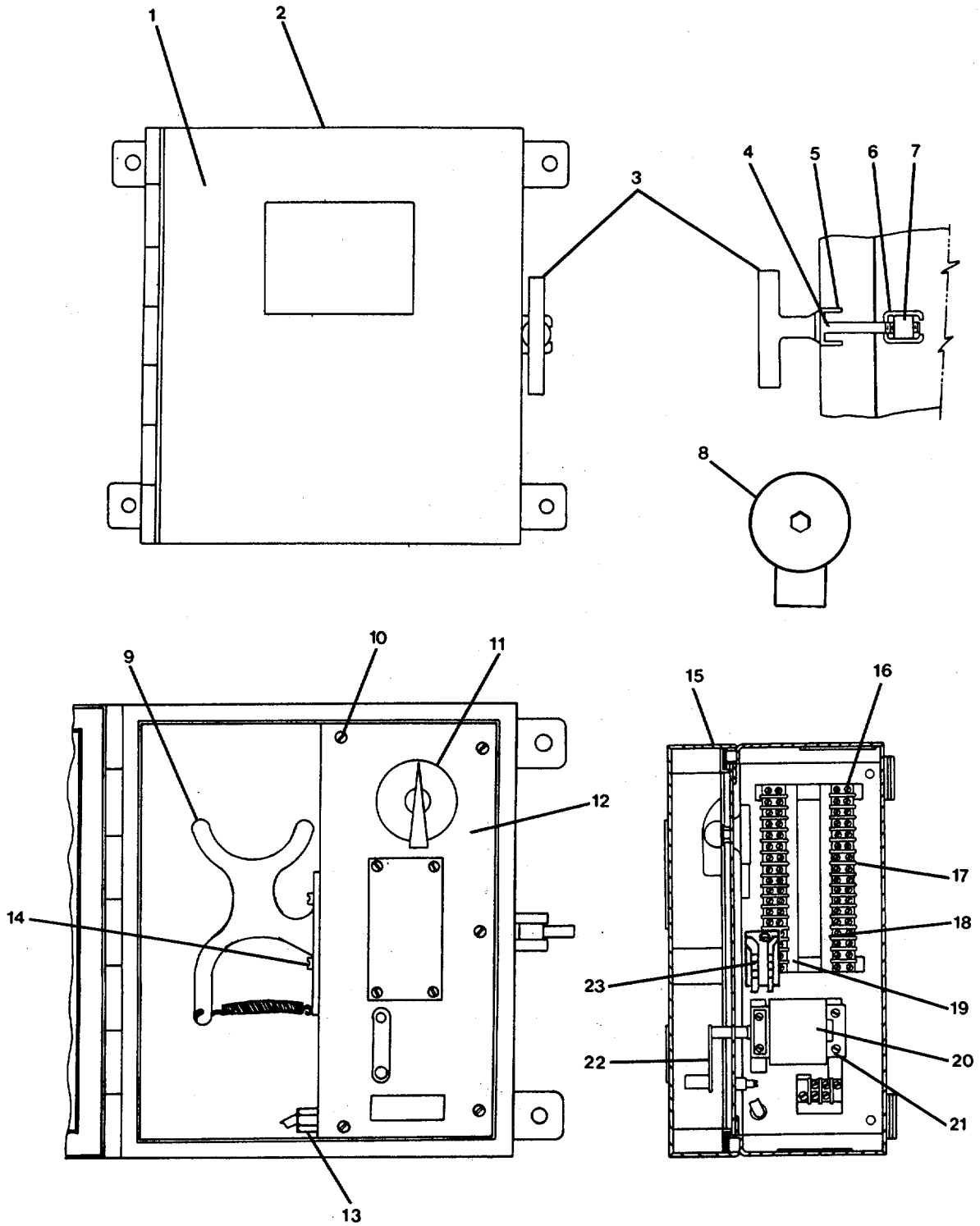

FIGURE 3-36. Sound Powered Telephone MWT-R-8.

- m. Remove telephone cord guard (13).
- n. Tag and disconnect electrical leads. Remove electrical bell (8).'

## REPAIR

Repair at this level of maintenance is by replacement of gasket (15), hand ringing generator (12), electromagnetic relay (23), and electrical bell (8).

## ASSEMBLY

- a. Install electrical bell (8). Remove tags and connect electrical leads.
- b. Install telephone cord guard (13).
- c. Install handset bracket (9) and self-locking screw (14).
- d. Install identification plates (18, 19).
- e. Install terminal board (17). Remove tags and connect electrical leads.
- f. Install drive screw (16).
- g. Install electromagnetic relay (23).
- h. Install manual control handle (22) and hand ringing generator (12).
- i. Install self-locking screw (21).
- j. Install telephone selector switch (11). Remove tags and connect electrical leads.
- k. Install gasket (15). Close mounting plate (12) and install self-locking screw (10).
- l. Install pivot rod (7) and pivot rod retainer (6).
- m. Install t-handle (3), handle guide (5), and self-locking screw (4).
- n. Close cover (1) on handset box (2), and tighten t-handle (3).
- o. Refer to paragraph 2-31 for replacement of sound powered telephone.

---

**3-40. Repair Sound Powered Telephone SFLR (MOD)-19. (Figure 3-37)**

---

**This task covers:****a. Disassembly****b. Repair****c. Assembly**

---

**INITIAL SETUP:**ToolsTool kit, electrician's,  
5180-00-391-1087Equipment ConditionSound powered telephone removed,  
para. 2-31 .Materials/PartsPilot light assembly P/N 441  
Push switch P/N 53-03  
Manual control handle P/N 24  
Hand ringing generator P/N 422  
Electromagnetic relay P/N 32A  
Warning tags, Item 1, Appendix C**DISASSEMBLY**

- a. Remove telephone cover (6).
- b. Tag and disconnect electrical leads. Remove telephone selector switch (7).
- c. Remove push switch (4).
- d. Remove pilot light assembly (1).
- e. Remove lens (2) and incandescent lamp (3).
- f. Remove manual control handle (5).
- g. Remove hand ringing generator (32).
- h. Remove self-locking screw (34), lockwasher (35), plain hexagon nut (36), and cable clamp (37).
- i. Remove self-locking screw (38), lockwasher (39) and plain hexagon nut (40).
- j. Remove self-locking screw (24), lockwasher (25) and cable clamp (26).
- k. Remove self-locking screw (14), lockwasher (13), and cable clamp (12).
- l. Remove cable (33).

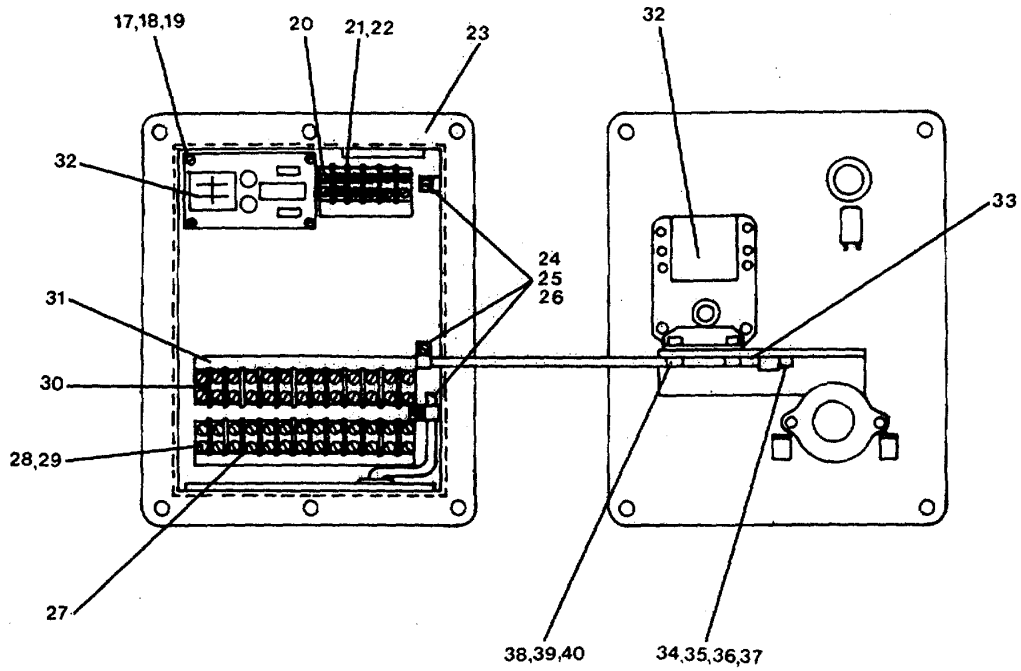
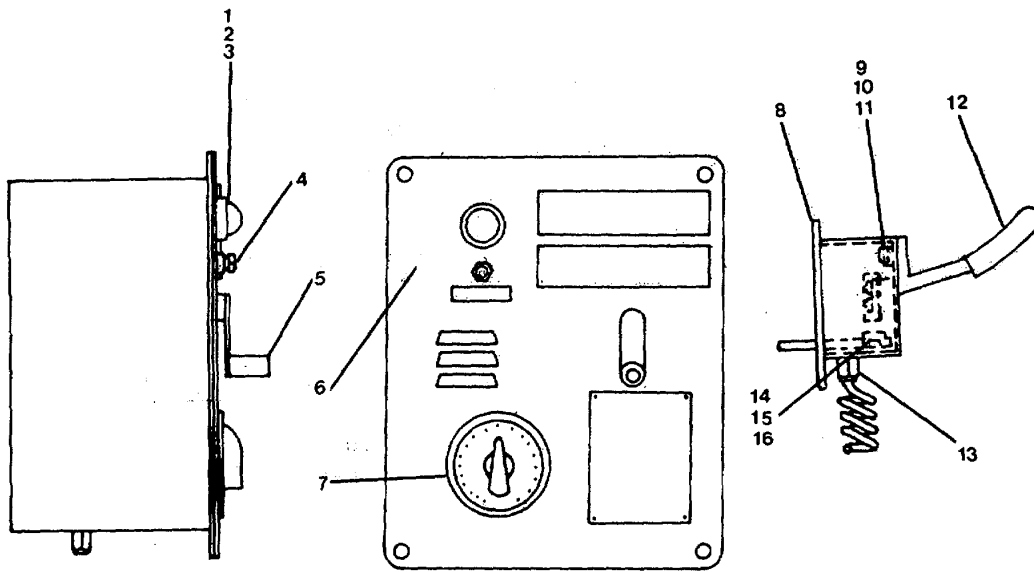

FIGURE 3-37. *Sound Powered Telephone SFLR (MOD)-19.*



- m. Remove self-locking screw (28) and lockwasher (29).
- n. Tag and disconnect electrical leads. Remove terminal board (27).
- o. Remove flat head screw (20).
- p. Remove identification plate (22).
- q. Tag and disconnect electrical leads. Remove terminal board (21).
- r. Remove identification plate (32).
- s. Tag and disconnect electrical leads. Remove terminal board (30).
- t. Remove self-locking screw (9), lockwasher (10), and plain hexagon nut (11).
- u. Remove headset bracket (12).
- v. Remove telephone cord guard (13).
- w. Remove self-locking screw (17), lockwasher (18), and standoff (19).
- x. Remove electromagnetic relay (32).

## REPAIR

Repair at this level of maintenance is by replacement of pilot light assembly (1), push switch (4), manual control handle (5), hand ringing generator (32), and electromagnetic relay (32).

## ASSEMBLY

- a. Install electromagnetic relay (32).
- b. Install standoff (19), lockwasher (18), and self-locking screw (17).
- c. Install telephone cord guard (13).
- d. Install headset bracket (12).
- e. Install plain hexagon nut (11), lockwasher (10) and self-locking screw (9).
- f. Install terminal board (30). Remove tags and connect electrical leads.
- g. Install identification plate (32).
- h. Install terminal board (21). Remove tags and connect electrical leads.
- i. Install identification plate (22).
- j. Install flat head screw (20).

- k. Install terminal board (27). Remove tags and connect electrical leads.
- l. Install lockwasher (29) and self-locking screw (28).
- m. Install cable (33).
- n. Install cable clamp (12), lockwasher (13), and self-locking screw (14).
- o. Install cable clamp (26), lockwasher (25), and self-locking screw (24).
- p. Install plain hexagon nut (40), lockwasher (39), and self-locking screw (38).
- q. Install cable clamp (37), plain hexagon nut (36), lockwasher (35) and self-locking screw (34).
- r. Install hand ringing generator (32).
- s. Install manual control handle (5).
- t. Install incandescent lamp (3) and lens (2).
- u. Install pilot light assembly (1).
- v. Install push switch (4).
- w. Install telephone selector switch (7). Remove tags and connect electrical leads.
- x. Install telephone cover (6).
- y. Refer to paragraph 2-31 for replacement of sound powered telephone.

**MAINTENANCE OF TANK LEVEL INDICATOR SYSTEM**

**3-41. Replace/Repair Level Sight Indicators. (Figure 3-38)**

This task covers:

- |             |                 |           |
|-------------|-----------------|-----------|
| a. Removal  | b. Disassembly, | c. Repair |
| d. Assembly | e. Replacement  |           |

**INITIAL SETUP:**

Tools

Tool kit, general mechanic's,  
5180-00-699-5273  
Torque wrench, 5720-01-092-3278

Materials/Parts

Indicator, VLI-86501-7  
Indicator, VLI-86501-20  
Indicator, VLI-86501-44  
Gasket P/N 86104  
Float P/N 86523  
Float tag P/N 86375  
Warning tags, Item 1, Appendix C

Equipment Condition

Inlet/outlet valves to /from tank  
closed and tagged "Out of Service  
Do Not Operate."  
Level of fluid in tank must be lower  
than indicator pick-up.

LOCATION	ITEM	ACTION	REMARKS
----------	------	--------	---------

**NOTE**

Level sight indicators VLI-86501-7,-20 and -44 are identical in purpose and function. The following procedures are compatible for each side mounted indicator listed above.

**REMOVAL**

- a. Remove flange mounting hardware and remove casing assembly (1) from tank.
- b. Remove flange gaskets.
- c. Remove pipe plug (13) and drain residual liquid from casing assembly (1). Retain pipe plug for assembly.

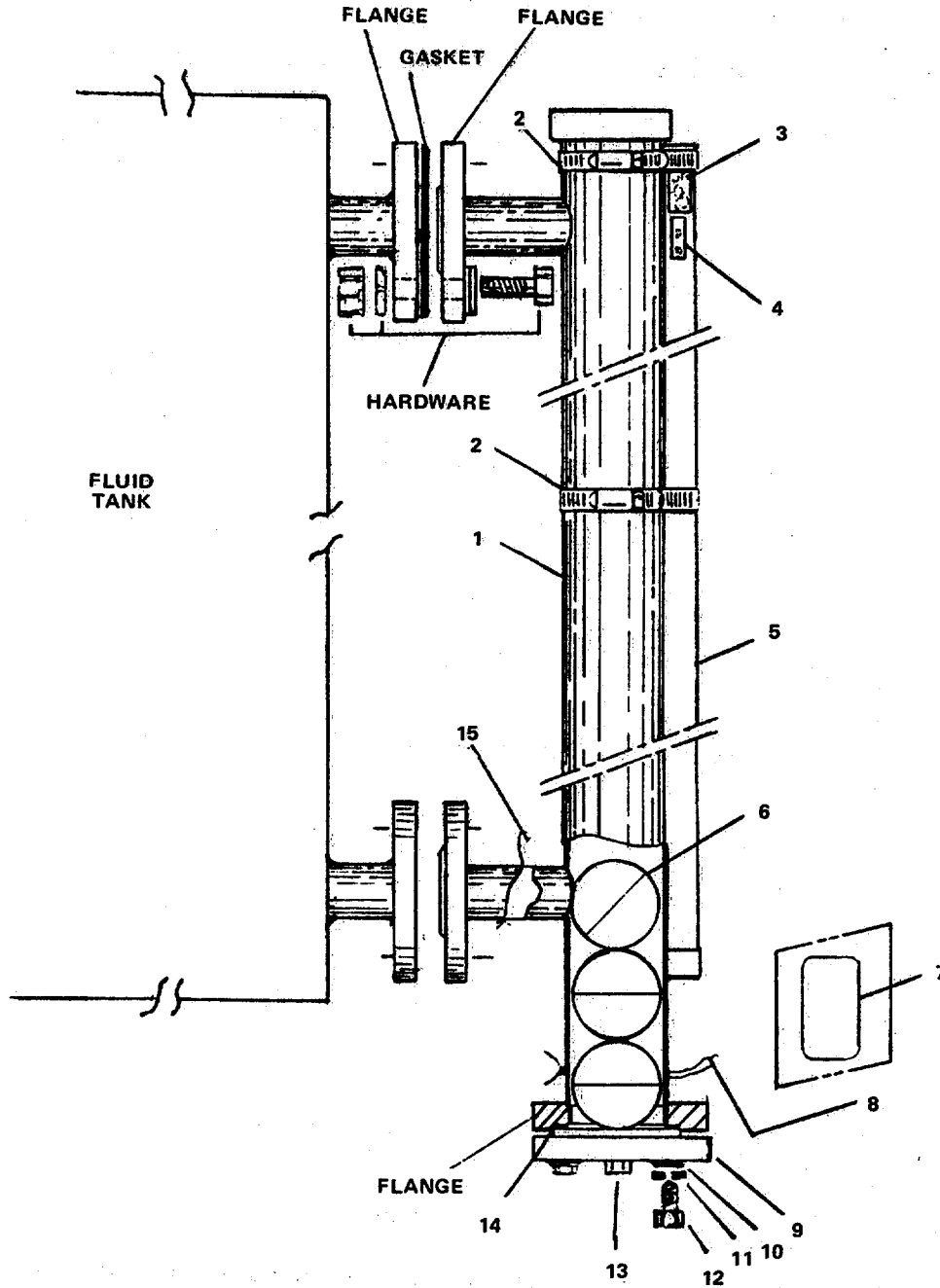

FIGURE 3-38. Level Sight Indicator. VLI-86501-7. -20. -44.

**DISASSEMBLY**

- a. Position sight level indicator on a clean flat surface.
- b. Loosen and remove two retaining straps (2) securing flag assembly (5) to casing assembly (1). Remove flag assembly.
- c. Remove four capscrews (12) flat washers (11), and lock washers (10) securing bottom cap (9) to casing assembly flange.
- d. Remove bottom cap and gasket (14).
- e. Remove three flow rate meter floats (6) from casing assembly (1).
- f. Detach float tag (8) and warning tag (15) from casing assembly.

**REPAIR**

Repair of sight level indicators VLI-86501-7,-20,-44 consists of replacing gasket (14), flow rate meter float (6), and float tag (8).

**ASSEMBLY**

- a. Position casing assembly on a clean flat assembly.
- b. Attach warning tag (15) and float tag (8) to casing assembly (1).
- c. Install three flow rate meter floats (6) into casing assembly.
- d. Position gasket (14) and bottom cap (9) on casing assembly flange.
- e. Install four cap screws (12), with flat washers (11) and lockwashers (10), and secure bottom cap to casing assembly flange. Torque 70 to 80 in-lb (7.84 to 8.96 Nom).
- f. Ensure that identification marks (3) and (4) are correctly positioned on flag assembly (5).
- g. Position flag assembly (5) on casing assembly (1).
- h. Install two retaining straps (2) and secure flag assembly to casing assembly.

**REPLACEMENT**

- a. Install pipe plug (13) on bottom cap (9).
- b. Position flange gaskets on tank flanges.
- c. Position sight level indicator on tank flanges with capscrews holes aligned.

- d. Install flange mounting hardware and secure casing assembly (1) to tank.
- e. Ensure that identification plate (7) is properly affixed to casing assembly (1).
- f. Open inlet/outlet valves to/from tank. Remove tags.

**3-42. Replace/Repair Level Sight Indicator. (Figure 3-39)****This task covers:**

a. Removal  
d. Assembly

b. Disassembly,  
e. Replacement

c. Repair

**INITIAL SETUP:**Tools

Tool kit, general mechanic's,  
5180-00-699-5273

up.

Materials/Parts

Indicator, VLI-86501-36  
Gasket P/N 86104  
Float P/N 86523  
Float tag P/N 86474  
Warning tags, Item 1, Appendix C

Equipment Condition

Inlet/outlet valves to /from tank  
closed and tagged "Out of Service Do Not Operate."  
Level of fluid in tank must be lower than indicator pick-

**REMOVAL**

- a. Remove flange mounting hardware and lift level sight indicator out of tank.
- b. Remove flange gasket from tank flange.

**DISASSEMBLY**

- a. Position level sight indicator on a clean flat surface.
- b. Loosen and remove two retaining straps (2, Sheet 1) securing flag assembly (3) to magnetic chamber assembly (1). Remove flag assembly.
- c. Remove four hex head cap screws (9, Sheet 2) flat washers (10) and lockwashers (11) securing magnetic chamber assembly (1) to mounting flange and float chamber assembly (4).
- d. Separate magnetic chamber assembly (1) from mounting flange and float chamber assembly (4).
- e. Remove gasket (13).
- f. Remove cotter pins (7).
- g. Separate and remove magnet assembly (6) from float rod (8).
- h. Remove cotter pin (12).

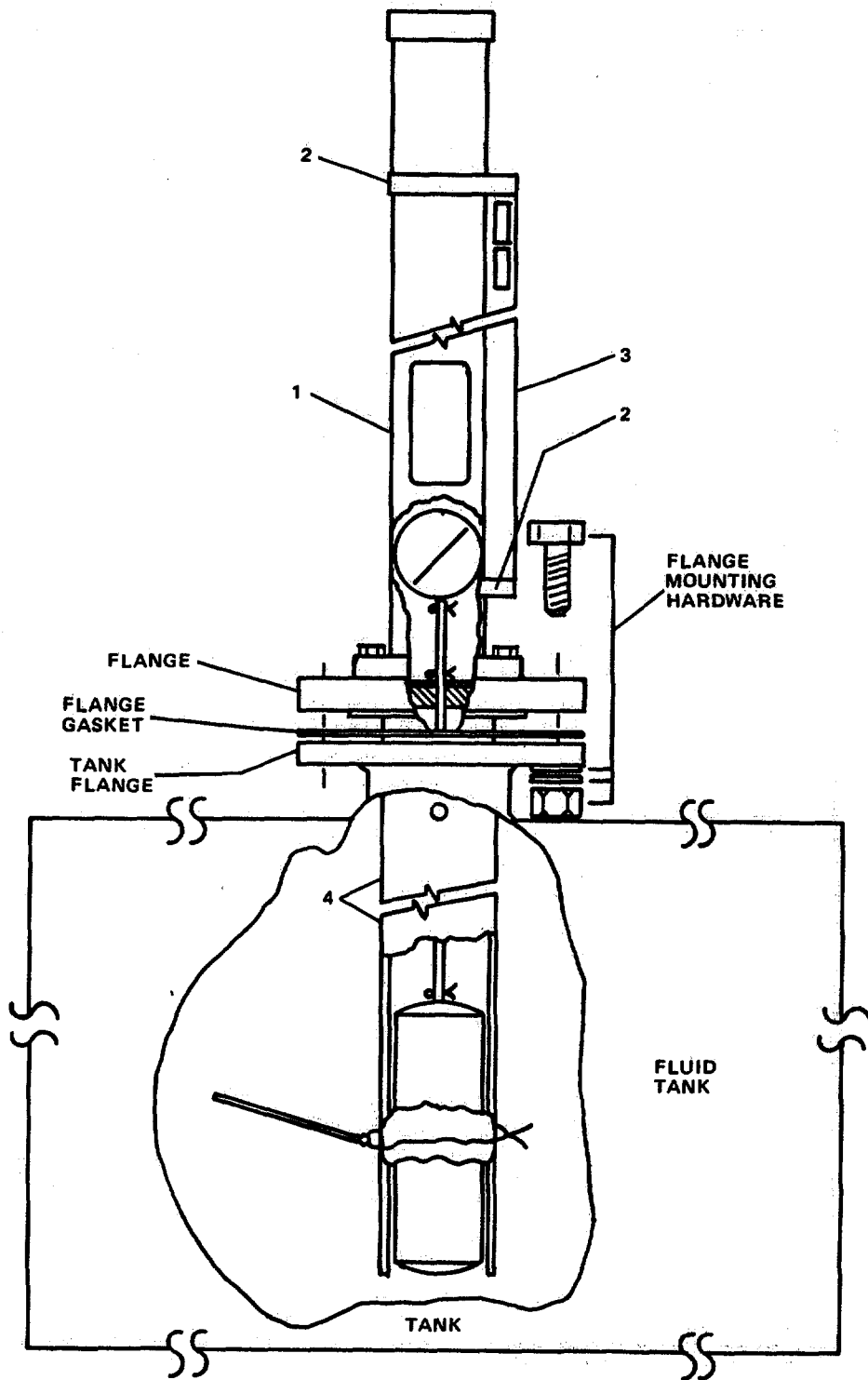

FIGURE 3-39. Level Sight Indicator. VLI-86200-36 (Sheet 1 of 2).



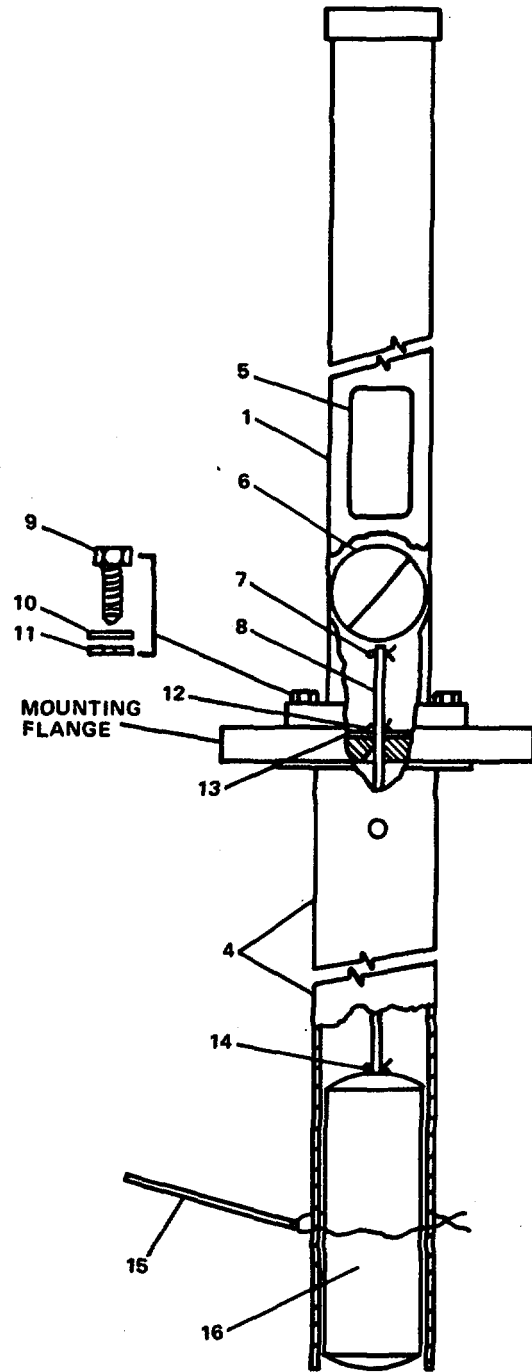

FIGURE 3-39. *Level Sight Indicator. VLI-86200-36 (Sheet 2 of 2).*

- i. Remove float (16) and float rod (8) from bottom of float chamber assembly (4).
- j. Remove cotter pin (14).
- k. Separate float from float rod.
- l. Detach float tag (15) from float chamber assembly.

## REPAIR

Repair of level sight indicator VLI-86200-36 consists of replacing gasket (13, Sheet 2), and float tag (15).

## ASSEMBLY

- a. Position magnetic chamber assembly (1) and float chamber assembly (4) on a clean flat surface.
- b. Attach float tag (15) to float chamber assembly.
- c. Position float rod (8) over float (16) with cotter pin holes aligned.
- d. Install cotter pin (14) and secure float to float rod by separating ends of cotter pin to an angle of approximately 60 to 90 degrees.
- e. Install float rod and float into bottom of float chamber assembly (4) with float rod directed through float rod hole in mounting flange.
- f. Install cotter pin (12) and secure float rod (8) above mounting flange by separating ends of cotter pin to an angle of approximately 60 to 90 degrees.
- g. Position magnet assembly (6) on float rod (8) with cotter pin holes aligned.
- h. Install cotter pin (7) and secure magnet assembly to float rod by separating ends of cotter pin to an angle of 60 to 90 degrees.
- i. Position gasket (13) over magnet assembly and onto flat surface of mounting flange, aligned with mounting capscrew holes.
- j. Position magnetic capscrew assembly (1) over magnet assembly (6) and aligned with mounting capscrew holes.
- k. Install four hex head capscrews (9) with flat washers (10) and lockwashers (11) to secure magnetic chamber assembly (1) to mounting flange and float chamber assembly (4).
- l. Position flag assembly (3, Sheet 1) on magnetic chamber assembly (1).
- m. Install two retaining straps (2) and secure flag assembly to magnetic chamber assembly.

**REPLACEMENT**

- a. Position flange gasket on tank flange with hardware mounting holes aligned.
- b. Lower level sight indicator into tank.
- c. Install flange mounting hardware and secure indicator to tank.
- d. Ensure that identification plate (5, Sheet 2) is properly affixed to magnetic chamber assembly (1, Sheet 1).

**3-43. Replace/Repair Float Switch. (Figure 3-40)**

---

**This task covers:**

- |   |   |   |
|---|---|---|
| <ul style="list-style-type: none"> <li>a. Removal</li> <li>d. Assembly</li> </ul> | <ul style="list-style-type: none"> <li>b. Disassembly,</li> <li>e. Replacement</li> </ul> | <ul style="list-style-type: none"> <li>c. Repair</li> </ul> |
|---|---|---|
- 

**INITIAL SETUP:**Tools

Tool kit, general mechanic's,  
5180-00-699-5273

Equipment Condition

Fluid drained from tank, inlet/out  
valves closed/secured and hatch  
cover removed as specified in paragraph 3-41 .

Materials/Parts

Float switch P/N  
XM-36480-120-100A-O-L  
Float switch P/N  
XM-36480-112-100A-O-L  
Float switch P/N  
XM-36480-47-3000A-2-L  
Float switch P/N  
XM-36480-95-1500A-O-L  
Float switch P/N  
XM-36480-125- 100A-W-L  
Float switch P/N  
XM-36460-36-4300A-O-L  
Float switch P/N  
XM-36460-52-2700A-O-L  
Electrical plug connector  
P/N 36468  
Special purpose electrical cable  
assembly P/N 36880-30-LP  
Tank penetration assembly  
P/N 36424  
Rivet insertion tool

---

**REMOVAL**

- a. Disconnect one end of special purpose electrical cable assembly (6, Sheet 1) at connectors (7) and opposite end at tank penetration assembly (5).
- b. Remove cable assembly from tank.
- c. Remove tank penetration assembly from top of tank.
- d. Remove mounting screws (2) from mounting bracket (1) and special spacer (4).

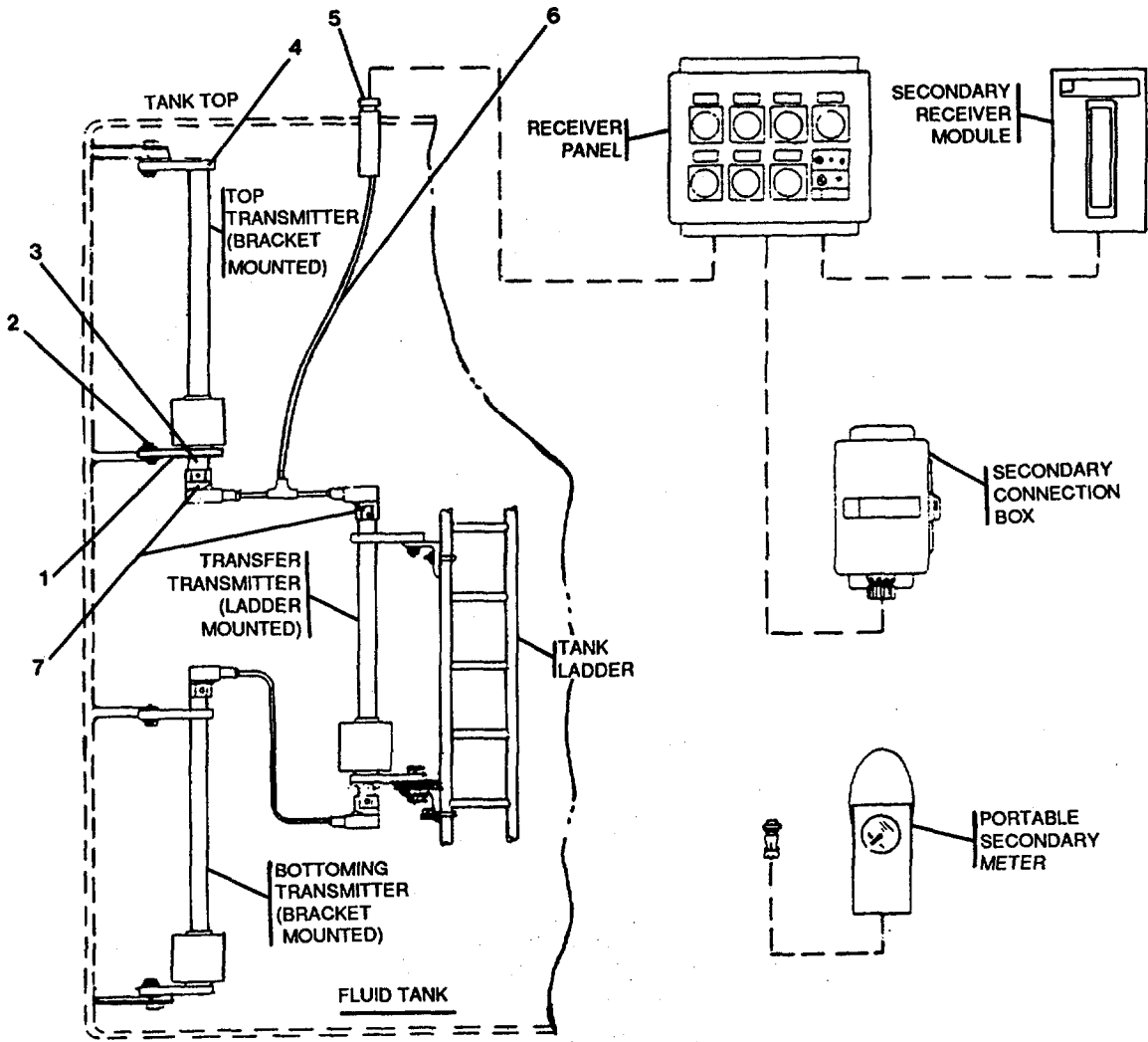

FIGURE 3-40. Multi-Transmitter Assembly (Sheet 1 of 2).

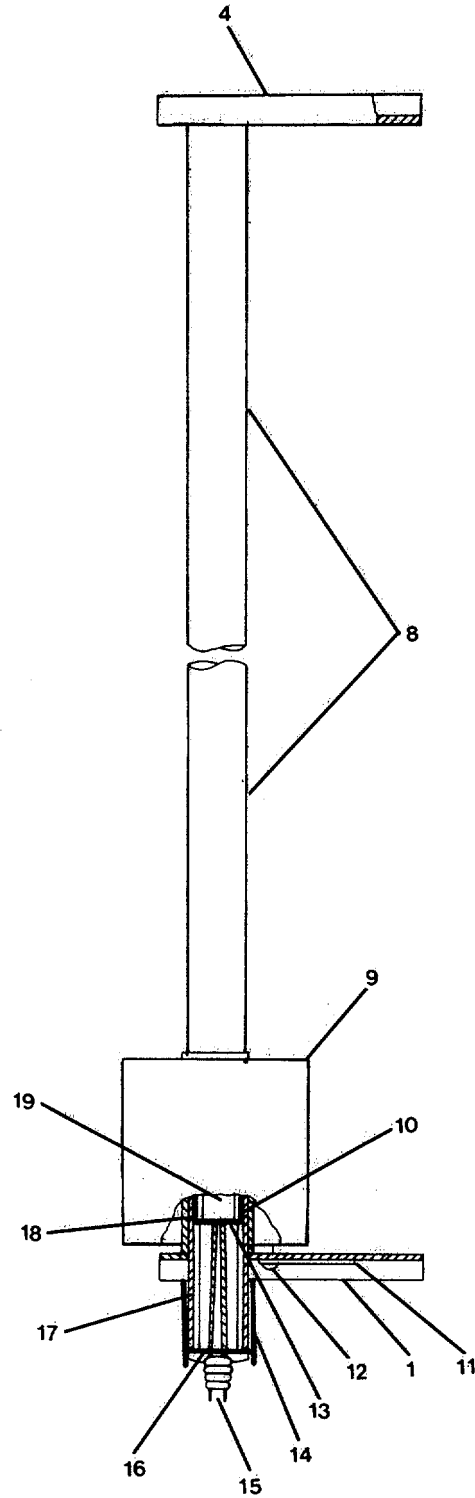

FIGURE 3-40. Float Switch (Transmitter Assembly) (Sheet 2 of 2).

- e. Remove float switch (3) from tank.
- f. Repeat steps a. through e. for remaining float switches (transmitter assemblies).

### DISASSEMBLY

- a. Position float switch (transmitter assembly) on a clean flat surface.
- b. Remove electrical plug connector (15, Sheet 2).
- c. Remove retaining ring (16).
- d. Remove split washer (14).
- e. Remove mounting bracket (1).
- f. Remove pop rivets (12) and remove identification plate (11).
- g. Remove float assembly (9).
- h. Remove split washer (10).
- i. Remove retaining ring (13).
- j. Remove spacer (17).
- k. Remove shock tube (18) and switch insert assembly (19).
- l. Separate special spacer (4) from stem assembly (8) by tapping on special spacer with a soft face hammer.

### REPAIR

Repair of float switch (transmitter assembly) consists of replacing float switch (3, Sheet 1), electrical plug connector (15, Sheet 2), special purpose electrical cable assembly (6, 7), and tank penetration assembly (5).

### ASSEMBLY

- a. Position stem assembly (8, Sheet 2) on a clean flat surface.
- b. Position special spacer (4) over stem assembly.
- c. Secure special spacer on stem assembly by tapping top of spacer with a soft face hammer until spacer is firmly seated.
- d. Install switch insert assembly (19) and shock tube (18) into stem assembly (8).

- e. Install spacer (17).
- f. Install retaining ring (13).
- g. Install split washer (1.0).
- h. Install float assembly (9).
- i. Position identification plate (11) on mounting bracket (1).
- j. Install pop rivets (12) to secure identification plate to mounting bracket.
- k. Install mounting bracket on stem assembly (8).
- l. Install split washer (14).
- m. Install retaining ring (16).
- n. Install electrical plug connector (15).

### REPLACEMENT

- a. Position float switch (3, sheet 1) on mounting supports in tank.
- b. Install mounting screws (2) and secure special spacer (4) and mounting bracket (1).
- c. Install tank penetration assembly (5) into top of tank.
- d. Position cable assembly over float switch and tank penetration assembly.
- e. Connect special purpose electrical cable assembly (6) at connectors (7).
- f. Repeat steps a. through e. for remaining float switches (transmitter assemblies).
- g. Replace hatch cover, fill fluid tank and restore inlet and outlet valves to normal operation as specified in paragraph 3-41 .



**3-44. Replace/Repair Receiver Module RE-39240.**

**This task covers:**

- |                    |                        |                  |
|--------------------|------------------------|------------------|
| <b>a. Removal</b>  | <b>b. Disassembly,</b> | <b>c. Repair</b> |
| <b>d. Assembly</b> | <b>e. Replacement</b>  |                  |

**INITIAL SETUP:**

Tools

Tool kit, general mechanic's,  
5180-00-699-5273

Equipment Condition

Electrical power to tank level  
indicator system turned OFF at  
Panel L102. Tag switch "Out of Service - Do Not  
Operate."

Materials/Parts

Receiver module RE-39240-7/M1-M7-38100  
Gasket P/N 37044, 37047  
Meter assembly P/N 43075  
Preformed packing P/N 17287, 23273  
Toggle switch P/N MS24659-22D, 30054  
Sonalert alarm P/N 39713  
Card guide P/N 37096  
Printed circuit connector P/N 32962  
Power supply P/N 38005  
Flasher module P/N 38105  
Circuit card assembly P/N 38100  
Simulator float P/N 37084  
Wire wound variable resistor  
P/N RV4SAYSB252A  
Knob P/N 22423  
Nonmetallic grommet P/N 30674  
Power transformer P/N 37652, 37653  
Electrolytic fixed capacitor P/N 37079  
Warning tags, Item 1, Appendix C

**REMOVAL** (Figure 3-41)

- a. Tag and disconnect electrical cable connectors at top of box assembly (4).
- b. Remove six plain hex nuts (3) lockwashers (2) and hexhead capscrews (1) securing receiver module box assembly to support mount.
- c. Remove box assembly.

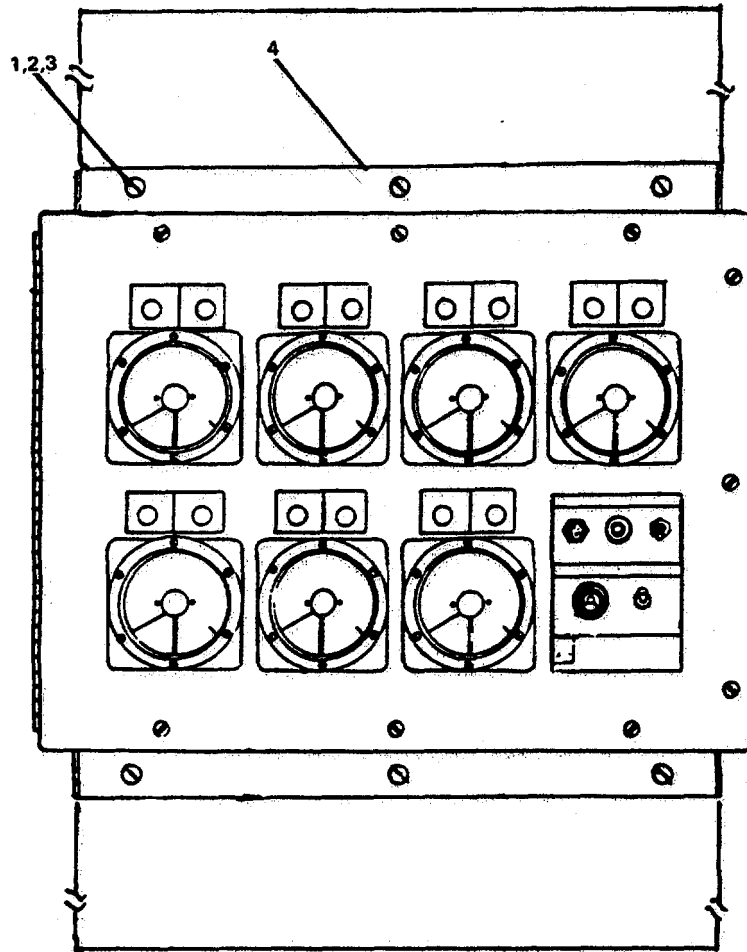

FIGURE 3-41. Receiver Module, Box Assembly.

**DISASSEMBLY**

- a. Position receiver module on a clean flat surface.
- b. Access panel (Figure 3-42 Sheet 1).
  - (1) Remove 10 machine screws (23) and lockwashers (20) securing bottom access panel (25) to box assembly (22).
  - (2) Remove access panel (25) and gasket (24).
  - (3) Repeat steps (1) and (2) to remove access panel at top of box assembly.
- c. Front panel.
  - (1) Remove nine hex head capscrews (19) and lockwashers (20).
  - (2) Open front panel.
  - (3) Remove gasket (21) from box assembly (22).
- d. Meter.
  - (1) Tag and disconnect electrical leads from meter (4).
  - (2) Remove four hex plain nuts (3), lockwashers (2), and machine screws (1) securing meter (4) to front panel.
  - (3) Remove meter from front panel.
  - (4) Repeat steps (1) through (3) to remove remaining meters.
- e. Indicator light.
  - (1) Tag and disconnect electrical leads; remove insulating tubing (6) from indicator light (5) at rear of front panel.
  - (2) Remove terminal lug (8) at rear of indicator light.
  - (3) Remove indicator from front panel.
  - (4) Repeat steps (1) and (3) to remove remaining indicator lights.
  - (5) Remove identification plates (7) and identification plate (11) from front panel.
- f. Toggle switch.
  - (1) Tag electrical wires and clip wire ends at toggle switch (10).
  - (2) Remove terminal lug (8) and preformed packing (9) from front panel.
  - (3) Remove toggle switch (10) from rear of front panel.

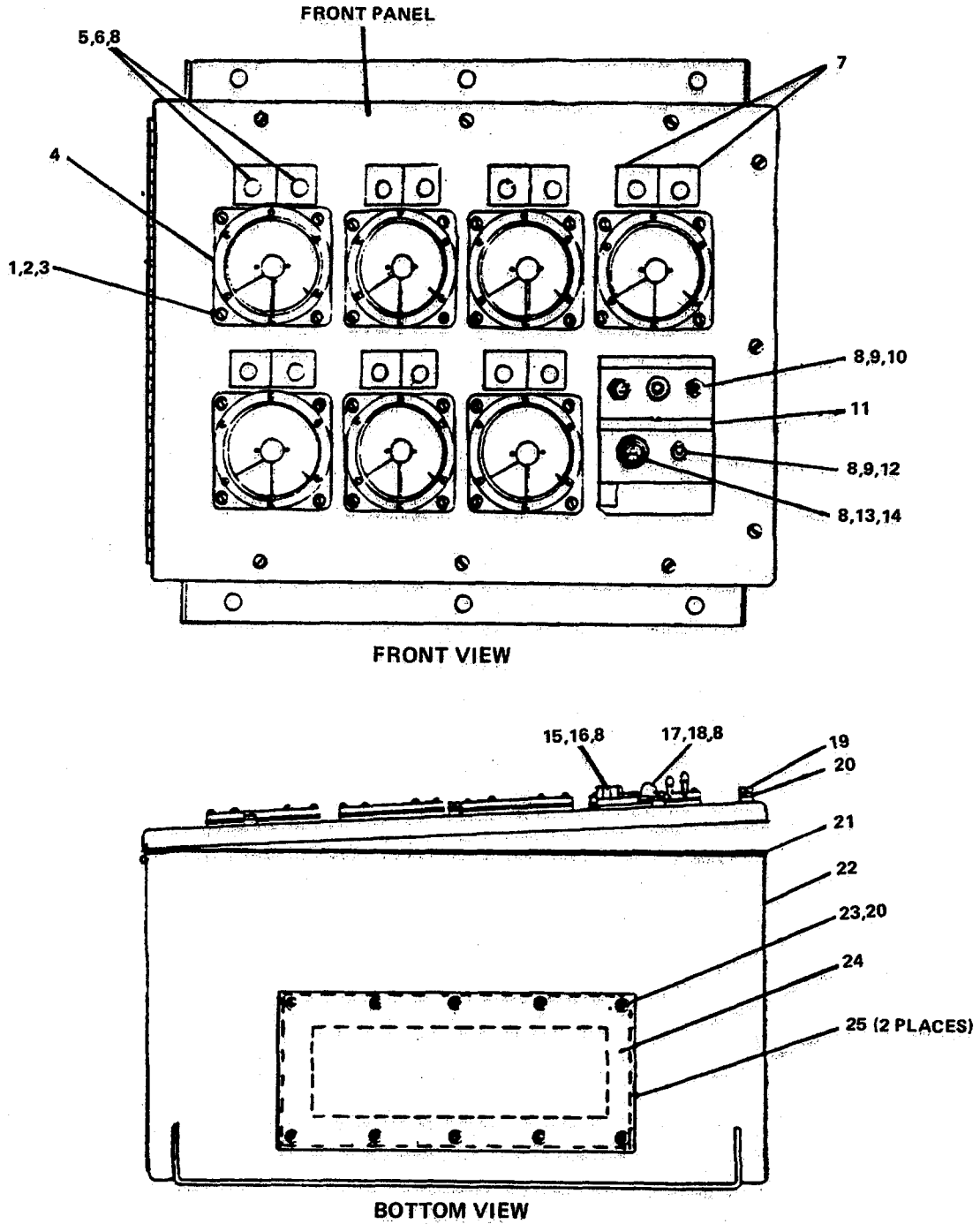

FIGURE 3-42. Receiver Module, RE-39240-7/M1-M7A-38100 (Sheet 1 of 4).

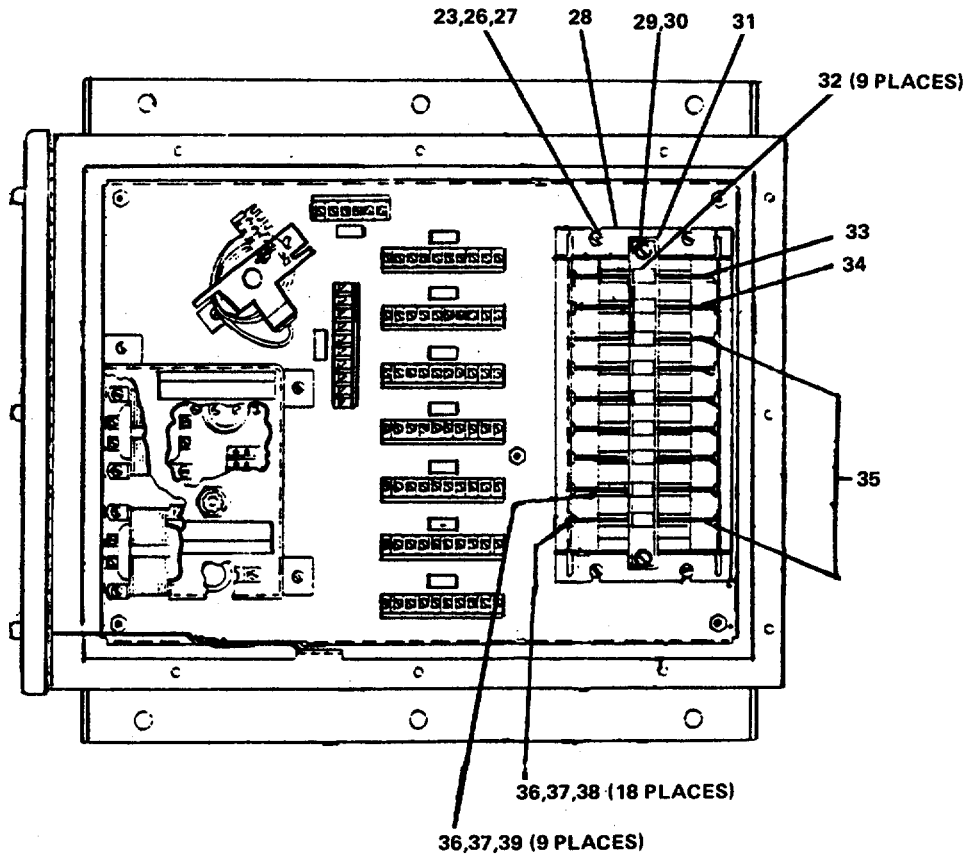

FIGURE 3-42. Receiver Module. RE-39240-7/M1-M7A-38100 (Sheet 2 of 4).

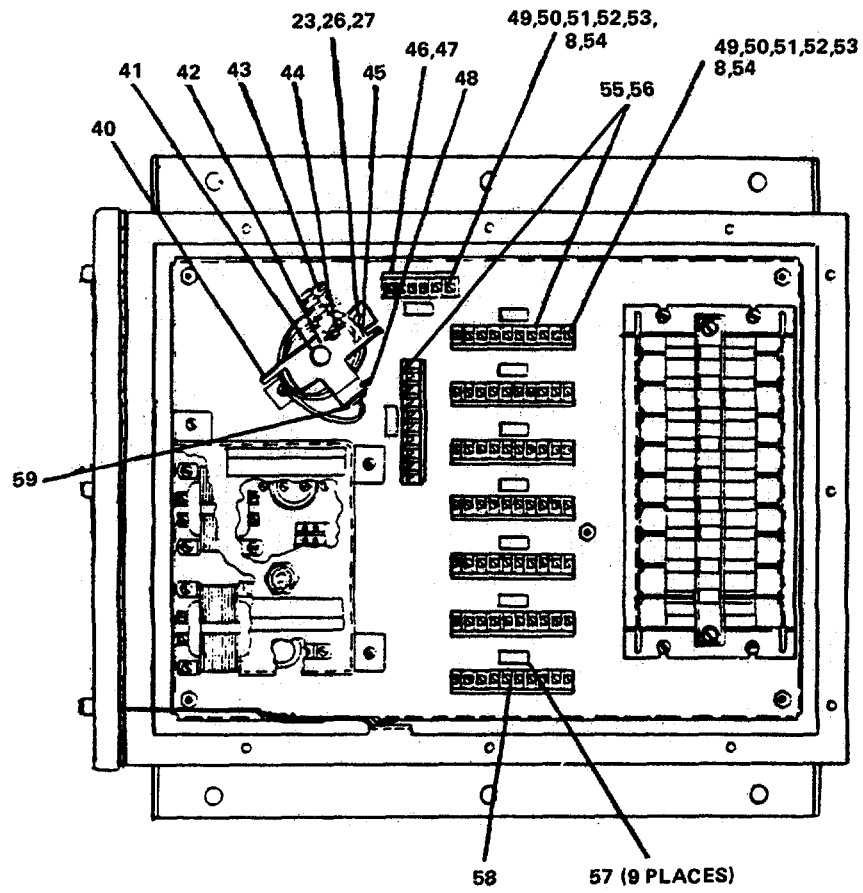

FIGURE 3-42. Receiver Module RE-39240-7/M1-M7A-38100 (Sheet 3 of 4).

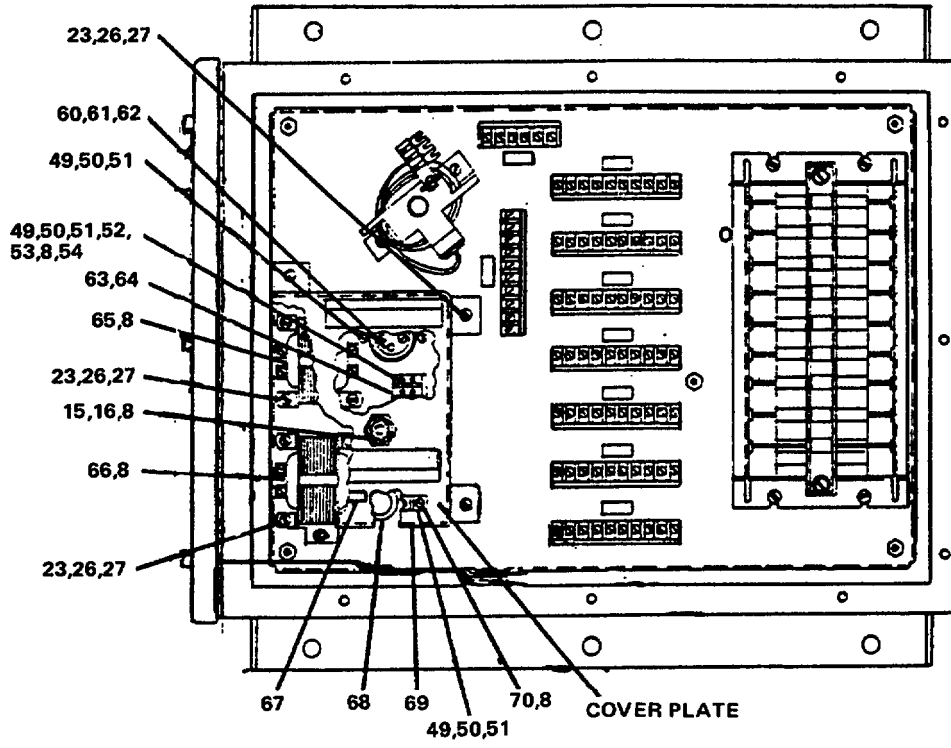

FIGURE 3-42. Receiver Module. RE-39240-7/M1-M7A-38100  
(Sheet 4 of 4).

(4) Repeat steps (1) through (3) to remove toggle switch (12).

g. Sonalert alarm.

(1) Tag electrical wires and clip wire ends at sonalert alarm (14).

(2) Remove terminal lug (8) and preformed packing (13) from front panel.

(3) Remove sonalert alarm (14) from rear of front panel.

h. Fuseholder.

(1) Tag electrical wires and clip wire ends at fuseholder (16).

(2) Remove terminal lug (8) at rear of fuseholder.

(3) Remove fuseholder (16) and fuse cartridge (15) from front panel.

i. Indicator light.

(1) Tag and disconnect electrical lead at rear of indicator light (17).

(2) Remove terminal lug (8) at rear of indicator light.

(3) Remove indicator light (17) and incandescent lamp (18) from front panel.

j. Card rack. (Figure 3-42, Sheet 2).

(1) Remove two hex head capscrews (29) and lockwashers (30) securing retaining bar (31) to card racks (28). Remove retaining bar.

(2) Remove identification markers (32) (9 places) from retaining bar (31).

(3) Remove power supply (33) and flasher module (34) circuit cards from card rack.

(4) Remove circuit card assembly (35).

(5) Remove four machine screws (36) and lockwashers (37) securing card guides (38) to sides of card rack (28).

(6) Remove card guides (38).

(7) Repeat steps (5) and (6) for remaining card guides.

(8) Tag and disconnect electrical leads to printed circuit connector (39).

(9) Remove two machine screws (36) and lockwashers (37) securing printed circuit connector (39) to card rack (28).

(10) Remove printed circuit connector.

(11) Repeat steps (8) through (10) to remove remaining printed circuit connectors (39).



(12) Remove four plain hex nuts (27) lockwashers (26) and machine screws (23) securing card rack (28) to rack mount.

(13) Remove card rack.

k. Simulator float. (Figure 3-42, Sheet 3).

(1) Remove identification plate (48) from simulator float (40).

(2) Remove wing nut (44) and release connecting strip (43).

(3) Unwind electrical cable (45) from simulator float.

(4) Disconnect snub bushing (59) from simulator float. Remove electrical cable.

(5) Remove two plain hex nuts (27), lockwashers (26) and machine screws (23) securing simulator float (40) to support mount.

(6) Remove simulator float, wire wound variable resistor (41) and knob (42).

(7) Remove terminal marker strip (47) from terminal block (46).

(8) Tag and disconnect electrical leads from wire hook-up (52).

(9) Disconnect cable ties (53) from cable harness.

(10) Remove terminal lug (8) securing tie mounting device (54) to support mount.

(11) Remove tie mounting device.

(12) Remove two plain hex nuts (51), lockwashers (50), and machine screws (49) securing terminal block (46) to support mount.

(13) Repeat steps (7) through (12) to remove terminal block (55) and terminal marker strips (56).

(14) Remove identification markers (56).

(15) Remove type - J jumpers (58).

1. Power supply. (Figure 3-42, Sheet 4).

(1) Unscrew and remove fuse cartridge (15) and fuse fuseholder (16) on cover plate.

(2) Remove four plain hex nuts (27), lockwashers (26), and machine screws (23) securing cover plate to support mounts.

(3) Position cover plate to expose fuseholder (16).

(4) Tag electrical wires and clip off wire ends at fuseholder.

- (5) Remove terminal lug (8) at rear of fuseholder.
- (6) Remove fuseholder from front of cover plate.
- (7) Remove cover plate.
- (8) Tag and disconnect leads from stud terminals (60) on electrolytic fixed capacitor (61).
- (9) Remove two plain hex nuts (51), lockwashers (50), and machine screws (49) securing shock pad (62) to support mount.
- (10) Remove shock pad and electrolytic fixed capacitor (61).
- (11) Remove terminal marker strip (64) from terminal block (63).
- (12) Tag and disconnect electrical leads from wire hook-up (52).
- (13) Disconnect cable ties (53) from cable harness.
- (14) Remove terminal lug (8) securing tie mounting device (54) to support mount.
- (15) Remove tie mounting device.
- (16) Remove two plain hex nuts (51), lockwashers (50), and machine screws (49) securing terminal block (63) to support mount.
- (17) Tag and disconnect electrical leads from power transformer (65) by removing four terminal lugs (8).
- (18) Remove four plain hex nuts (27), lockwashers (26), and machine screws (23) securing power transformer (65) to support mount.
- (19) Remove power transformer.
- (20) Repeat steps (17) through (19) to remove power transformer.
- (21) Remove identification markers (67) and (69),.
- (22) Tag and disconnect electrical leads from terminal block (70).
- (23) Remove two plain hex nuts (51), lockwashers (50), and machine screws (49) securing terminal block (70) to support mount. Remove terminal block.
- (24) Pull electrical leads clear of nonmetallic grommet (68).
- (25) Remove nonmetallic grommet.

## REPAIR

Repair of receiver module RE-39240-7/M1-M7A-38100 consists of replacing gasket (21, 24), meter assembly (4), preformed packing (9, 13), toggle switch (10, 12), sonalert alarm (14), card guides (38), printed circuit connectors (39), power supply (33), flasher module (34), circuit card assembly (35), simulator float (40), variable wire wound resistor (41), knob (42), nonmetallic grommet (68), power transformers (65, 66), and electrolytic fixed capacitor (61).

## ASSEMBLY

- a. Position receiver module on a clean, flat surface.
- b. Power supply. (Figure 3-42, (Sheet 4).
  - (1) Install nonmetallic grommet (68).
  - (2) Run electrical leads through nonmetallic grommet.
  - (3) Position terminal block (70) on support mount.
  - (4) Install two machine screws (49), lockwashers (50), and plain hex nuts (51) and secure terminal block to support mount.
  - (5) Connect electrical leads to terminal block (70). Remove tags.
  - (6) Attach identification markers (69) and (67).
  - (7) Position power transformer (65) over support mount.
  - (8) Install four machine screws (23), lockwashers (26), and plain hex nuts (27) and secure power transformer (65) to support mount.
  - (9) Connect electrical leads to power transformer (65) using four terminal lugs (8). Remove tags.
  - (10) Repeat steps (7) through (9) to install power transformer (66).
  - (11) Position terminal block (63) over support mount.
  - (12) Install two machine screws (49), lockwashers (50), and plain hex nuts (51) and secure terminal block to support mount.
  - (13) Position tie mounting device (54) on support mount and secure tie mounting device using terminal lug (8).
  - (14) Connect cable ties (53) to cable harness.
  - (15) Connect electrical leads to wire hook-up (52). Remove tags.
  - (16) Attach terminal marker strip (64) to terminal block (63).

- (17) Position electrolytic fixed capacitor (61) into shock pad (62).
- (18) Install two machine screws (49), lockwashers (50), and plain hex nuts (51) and secure electrolytic fixed capacitor to support mount with shock pad (62).
- (19) Connect electrical leads to stud terminals (60) on electrolytic fixed capacitor (61). Remove tags.
- (20) Position fuseholder (16) with fuse cartridge (15) enclosed, into fuseholder mounting hole on cover plate.
- (21) Install terminal lug (8) at rear of fuseholder.
- (22) Install electrical wire ends on fuseholder (16). Remove tags.
- (23) Position cover plate over mounting screw holes.
- (24) Install four machine screws (23), lockwashers (26), and plain hex nuts (27) and secure cover plate to support mount.

c. Simulator float. (Figure 3-42, Sheet 3).

- (1) Install type - J jumpers (58).
- (2) Attach identification markers (57).
- (3) Position terminal block (46) on support mount.
- (4) Install two machine screws (49), lockwashers (50), and plain hex nuts (51) and secure terminal block (46) to support mount.
- (5) Position tie mounting device (54) on support mount.
- (6) Install terminal lug (8) and secure tie mounting device to support mount.
- (7) Connect cable ties (53) to cable harness.
- (8) Connect electrical, leads to wire hook-up (52). Remove tags.
- (9) Attach terminal marker strip (47) to terminal block (46).
- (10) Repeat steps (3) through (9) to install terminal blocks (55) and terminal marker strips (56).
- (11) Position simulator float (40), wirewound variable resistor (41), and knob (42) over support mount.
- (12) Install two machine screws (23), lockwashers (26), and plain hex nuts (27) and secure simulator float (40) to support mount.
- (13) Connect snub bushing (59) on opposite end of electrical cable (45) to simulator float

- (14) Wind electrical cable (45) clockwise onto simulator float.
- (15) Position connecting strip (43) on simulator float.
- (16) Install wing nut (44) and secure connecting strip to simulator float.
- (17) Attach identification plate (48) to simulator float.

d. Card rack. (Figure 3-42, Sheet 2).

- (1) Position card rack (28) over support mount.
- (2) Install four machine screws (23), lockwashers (26), and plain hex nuts (27) and secure card rack to support mount.
- (3) Position printed circuit connector (39) over support mount on card rack (28).
- (4) Install two machine screws (36) and lockwashers (37) and secure printed circuit connector (39) to support mount on card rack.
- (5) Connect electrical leads to printed circuit connector. Remove tags.
- (6) Repeat steps (3) through (5) to install remaining printed circuit connectors (39).
- (7) Position card guide (38) on each side of card rack (28).
- (8) Install two machine screws (36) and lockwashers (37) on each side of card rack and secure card guides to card rack.
- (9) Repeat steps (7) and (8) to install remaining card guides (38).
- (10) Install circuit card assemblies (35) into card rack (28).
- (11) Install flasher module (34) and power supply (33) circuit cards into card rack.
- (12) Attach identification markers (32) on retaining bar (31).
- (13) Position retaining bar (31) over card rack (28) with mounting screw holes aligned.
- (14) Install two hexhead capscrews (29) and lockwashers (30) and secure retaining bar to card rack.

e. Indicator light. (Figure 3-42, Sheet 1).

- (1) Position indicator light (17) and incandescent lamp (18) on front panel.
- (2) Install terminal lug (8) at rear of indicator light.
- (3) Connect electrical leads at rear of indicator light (17). Remove tag.

f. Fuseholder.

- (1) Position fuseholder (16) and fuse cartridge (15) on front panel.
- (2) Install terminal lug (8) at rear of fuseholder.
- (3) Connect electrical wire ends to fuseholder. Remove tag.

g. Sonalert alarm.

- (1) Position sonalert alarm (14) at rear of front panel.
- (2) Install preformed packing (13) and terminal lug (8) on sonalert alarm at front panel.
- (3) Connect electrical wire ends to sonalert alarm. Remove tag.

h. Toggle switch.

- (1) Position toggle switch (10) at rear of front panel.
- (2) Install preformed packing (9) and terminal lug (8) on toggle switch at front panel.
- (3) Connect electrical wire ends to toggle switch. Remove tag.
- (4) Repeat steps (1) through (3) to install toggle switch (12).

i. Indicator light.

- (1) Attach identification plates (7) and identification plate (11) to front panel.
- (2) Position indicator light (5) on front panel.
- (3) Install terminal lug (8) at rear of indicator light.
- (4) Connect electrical leads; and install insulating tubing (6) at rear of indicating light. Remove tag.
- (5) Repeat steps (2) through (4) to install remaining indicator lights.

j. Meter.

- (1) Position meter (4) on front panel.
- (2) Install four machine screws (1), lockwashers (2), and plain hex nuts (3) and secure meter to front panel.
- (3) Connect electrical leads to meter. Remove tags.
- (4) Repeat steps (1) through (3) to install remaining meters.

k. Front panel.

- (1) Install gasket (21) on box assembly (22).
- (2) Close front panel.
- (3) Install nine hex head capscrews (19) and lockwashers (20) and secure front panel to box assembly (22).

1. Access panel.

- (1) Position gasket (24) and access panel (25) on bottom of box assembly (22).
- (2) Install 10 machine screws (23) and lockwasher (20) and secure access panel to box assembly.
- (3) Repeat steps (1) and (2) to install access panel at top of box assembly.

**REPLACEMENT (Figure 3-41)**

- a. Position box assembly (4) over support mount with mounting screw holes aligned.
- b. Install six hex head capscrews (1), lockwasher (2) and plain hex nuts (3) and secure box assembly to support mount.
- c. Connect electrical cable connectors at top of box assembly. Remove tags.
- d. Turn on electrical power at panel L102. Remove tags.

**3-45. Replace/Repair Receiver Module RE-39260.**

**This task covers:**

- |            |                |             |
|------------|----------------|-------------|
| a. Removal | b. Disassembly | d. Assembly |
| c. Repair  | e. Replacement |             |

**INITIAL SETUP:**

Tools

Tool kit, general mechanic's,  
5180-00-699-5273

Equipment Condition

Electrical power to tank level  
indicator system turned OFF  
at Panel L102. Tag switch  
"Out of Service - Do Not  
Operate."

Materials/Parts

Receiver module  
RE-39260-12/M1-M8-38100/M9-M12-38139  
Gasket P/N 37064, 37081, 37047  
Meter assembly P/N 43075 (12)  
Preformed packing P/N 17287 (2), 23273  
Toggle switch P/N MS24659-22D  
Sonalert alarm P/N 39713  
Card guide P/N 37096 (38)  
Printed circuit connector  
P/N 32962 (19)  
Power supply P/N 38005 (2)  
Flasher module P/N 38105 (2)  
Circuit card assembly P/N 38100 (15)  
Simulator float P/N 37084  
Wire wound variable resistor  
P/N RVASAYS252A  
Knob P/N 22423  
Nonmetallic grommet P/N 30674 (2)  
Power transformer P/N 37652 (2),  
37653 (2)  
Electrolytic fixed capacitor  
P/N 37079 (2)  
Warning tags, Item 1, Appendix C

**REMOVAL (Figure 3-44)**

- a. Tag and disconnect electrical cable connectors at top of box assembly (4).
- b. Remove six plain hex nuts (3), lockwashers (2), and hex head capscrews (1)securing receiver module box assembly to support mount.
- c. Remove box assembly



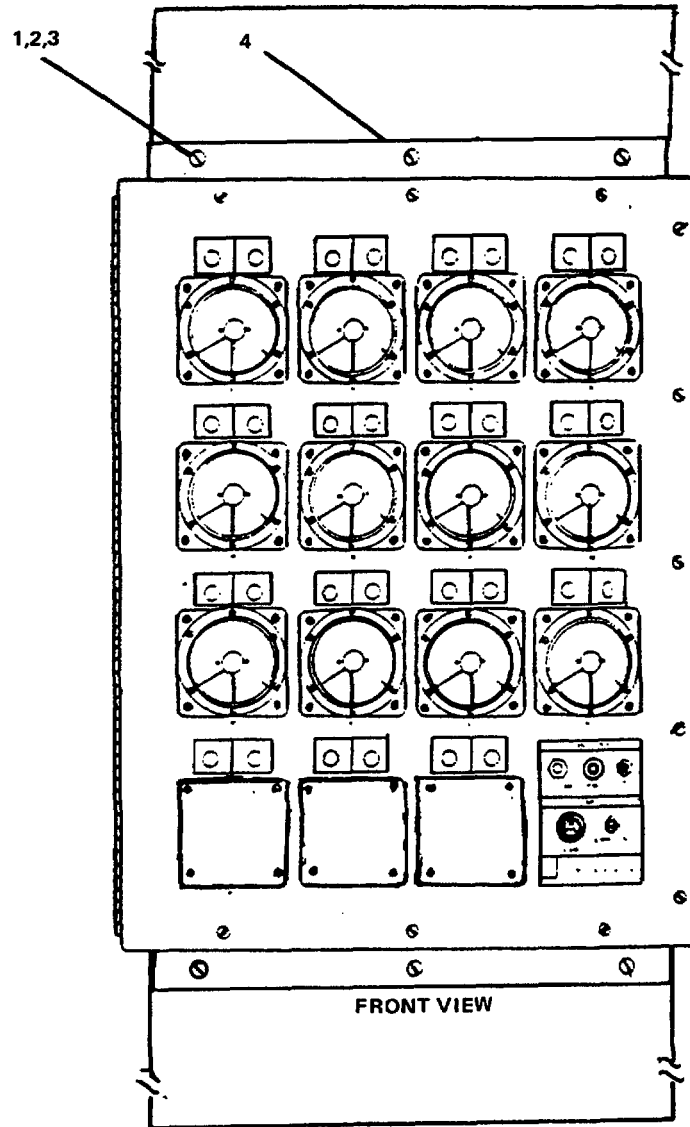

FIGURE 3-44. *Receiver Module, Box Assembly.*

**DISASSEMBLY**

- a. Position receiver module on a clean flat surface.
- b. Access panel. (Figure 3-45, Sheet 1).
  - (1) Remove 10 machine screws (23) and lockwashers (20) securing bottom access panel (25) to box assembly (22).
  - (2) Remove access panel (25) and gasket (24).
  - (3) Repeat steps (1) and (2) to remove access panel at top of box assembly.
- c. Front panel.
  - (1) Remove nine hex head capscrews (19) and lockwashers (20).
  - (2) Open front panel.
  - (3) Remove gasket (21) from box assembly (22).
- d. Meter.
  - (1) Tag and disconnect electrical leads from meter (4).
  - (2) Remove four hex plain nuts (3), lockwashers (2), and machine screws (1) securing meter (4) to front panel.
  - (3) Remove meter from front panel.
  - (4) Repeat steps (1) through (3) to remove remaining meters.
- e. Indicator light.
  - (1) Tag and disconnect electrical leads; and remove insulating tubing (6) from indicator light (5) at rear of front panel.
  - (2) Remove terminal lug (8) at rear of indicator light.
  - (3) Remove indicator from front panel.
  - (4) Repeat steps (1) and (3) to remove remaining indicator lights.
  - (5) Remove identification plates (7) and identification plate (11) from front panel.
- f. Toggle switch.
  - (1) Tag electrical wires and clip wire ends at toggle switch (10).
  - (2) Remove terminal lug (8) and preformed packing (9) from front panel.
  - (3) Remove toggle switch (10) from rear of front panel.

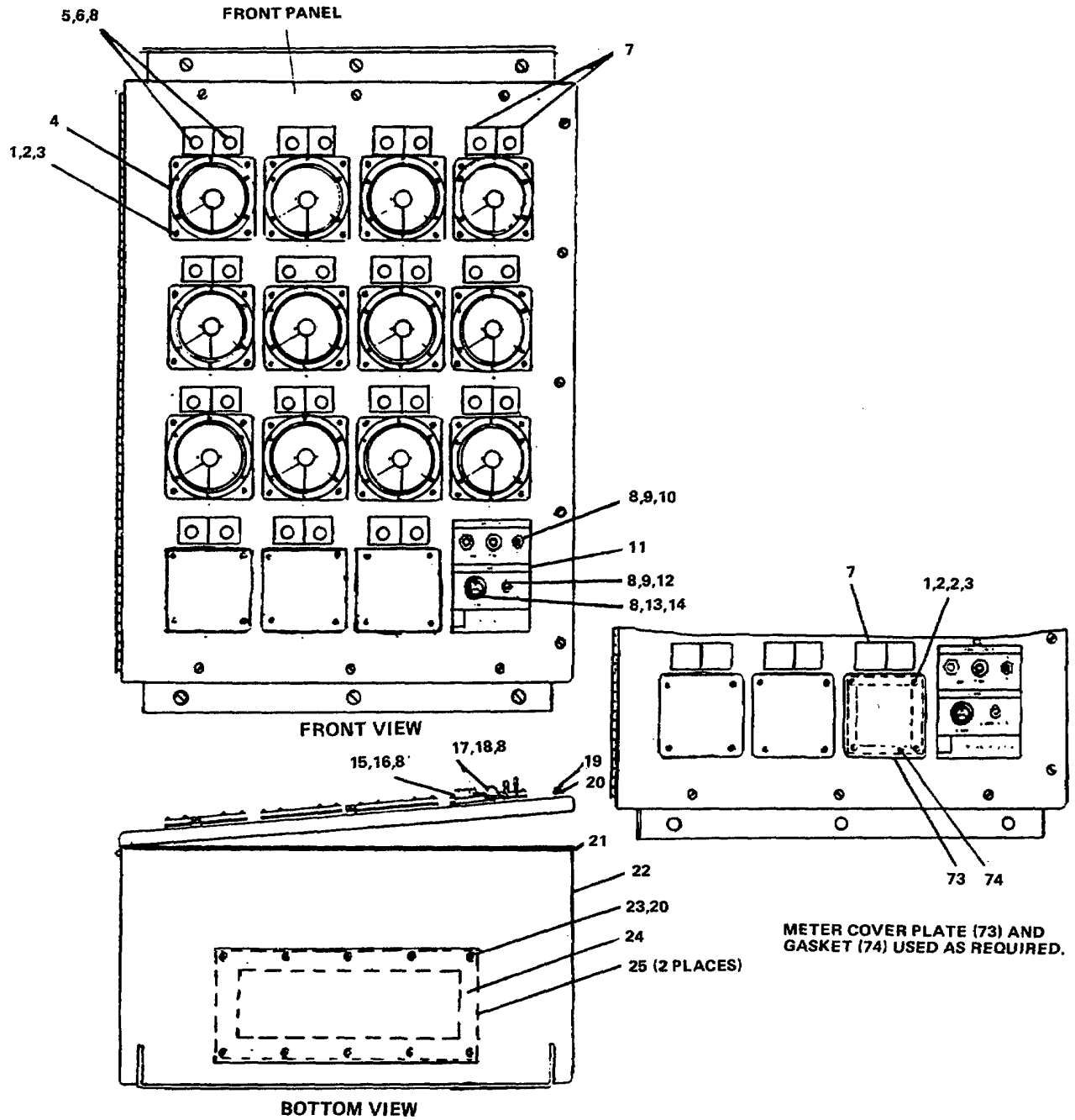

FIGURE 3-45. Receiver Module, RE-39260-12/MI-M8-38100/M9-M12-38139  
(Sheet 1 of 5).

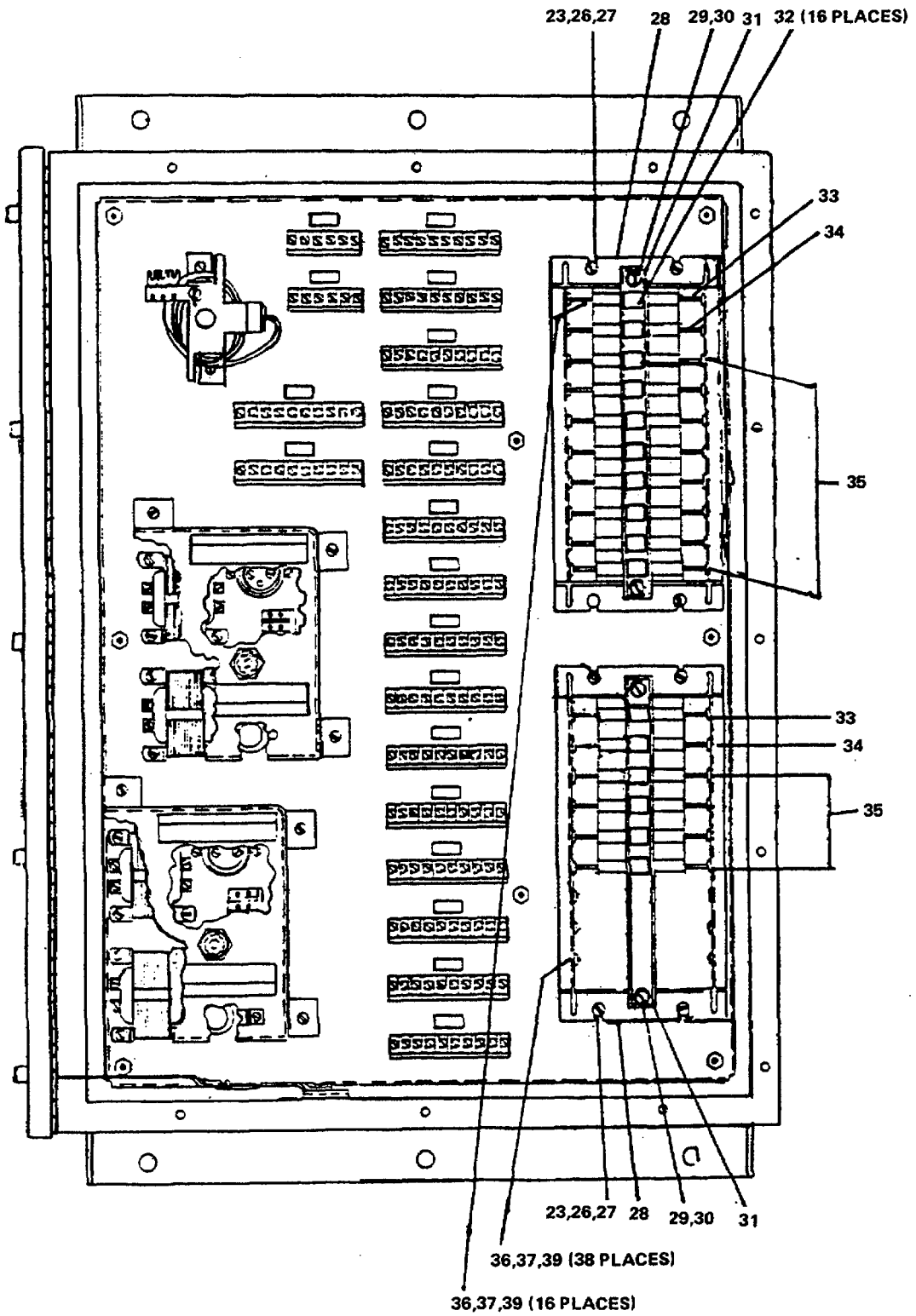

FIGURE 3-45. Receiver Module. RE-39260-12/MI-M8-38100/M9-M12-38139 (Sheet 2 of 5).

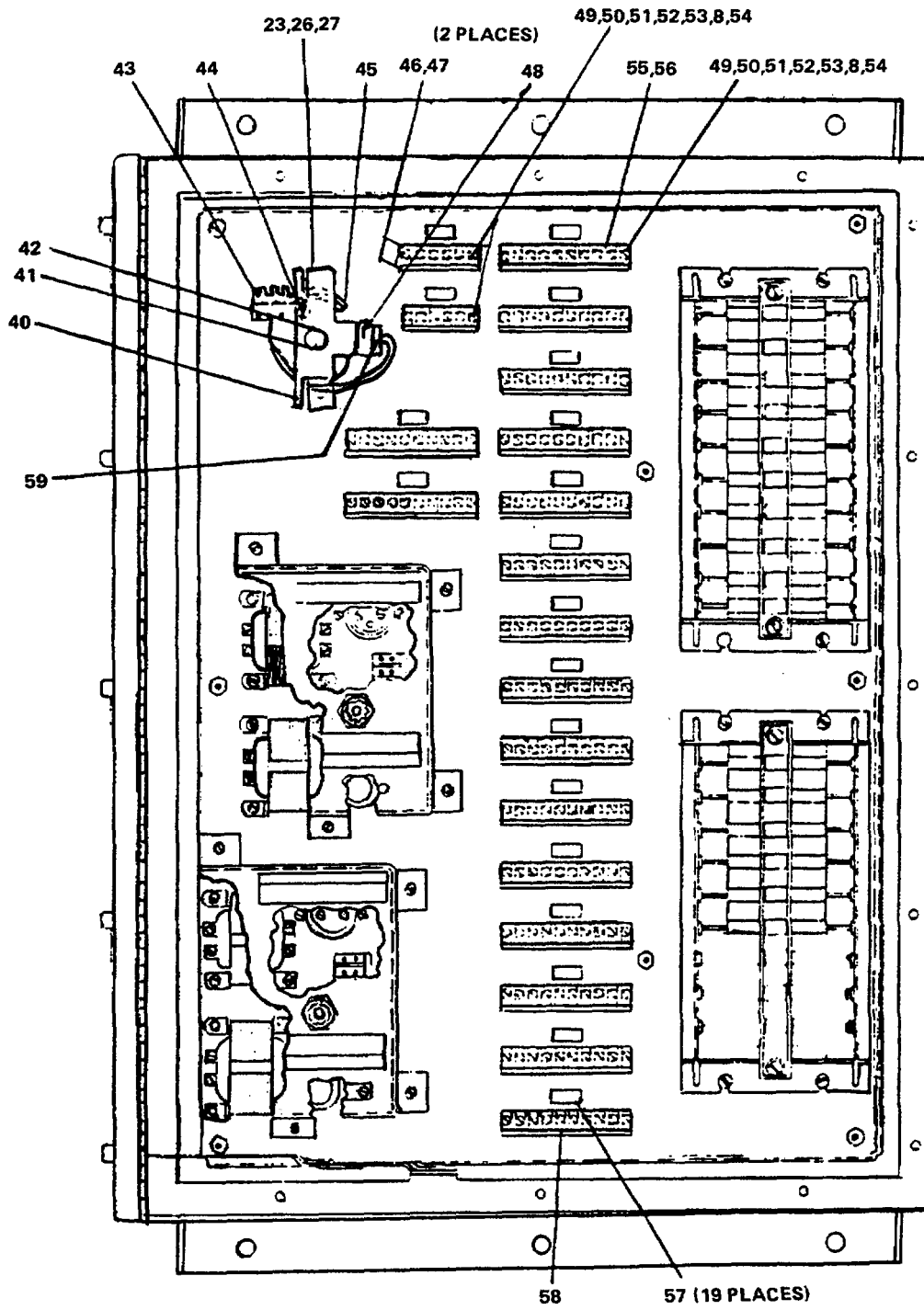

FIGURE 3-45. Receiver Module, RE-39260-12/MI-M8-38100/M9-M12-38139  
(Sheet 3 of 5).

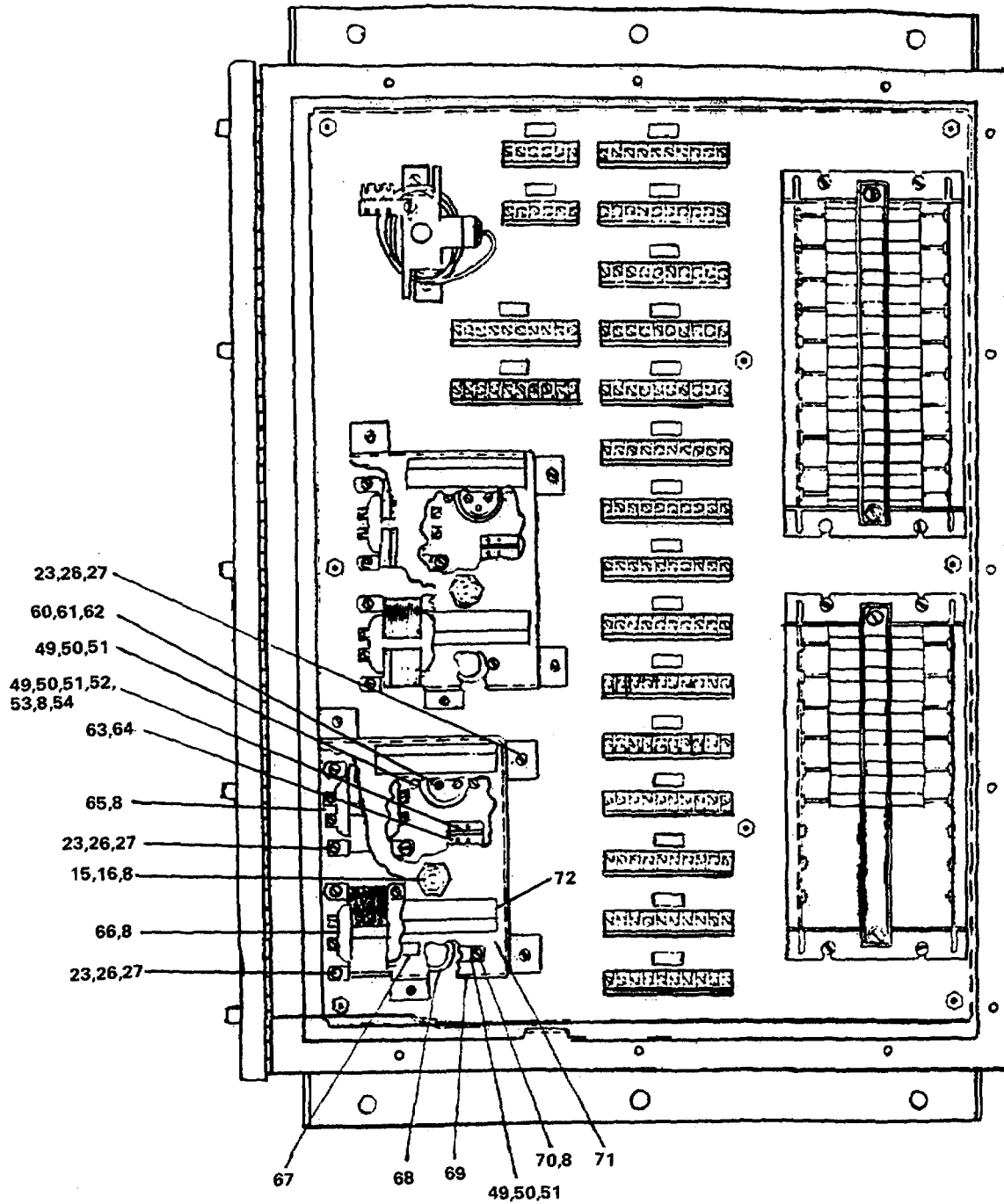

FIGURE 3-45. Receiver Module, RE-39260-12/M1-M8-38100/M9-M12-38139  
(Sheet 4 of 5).

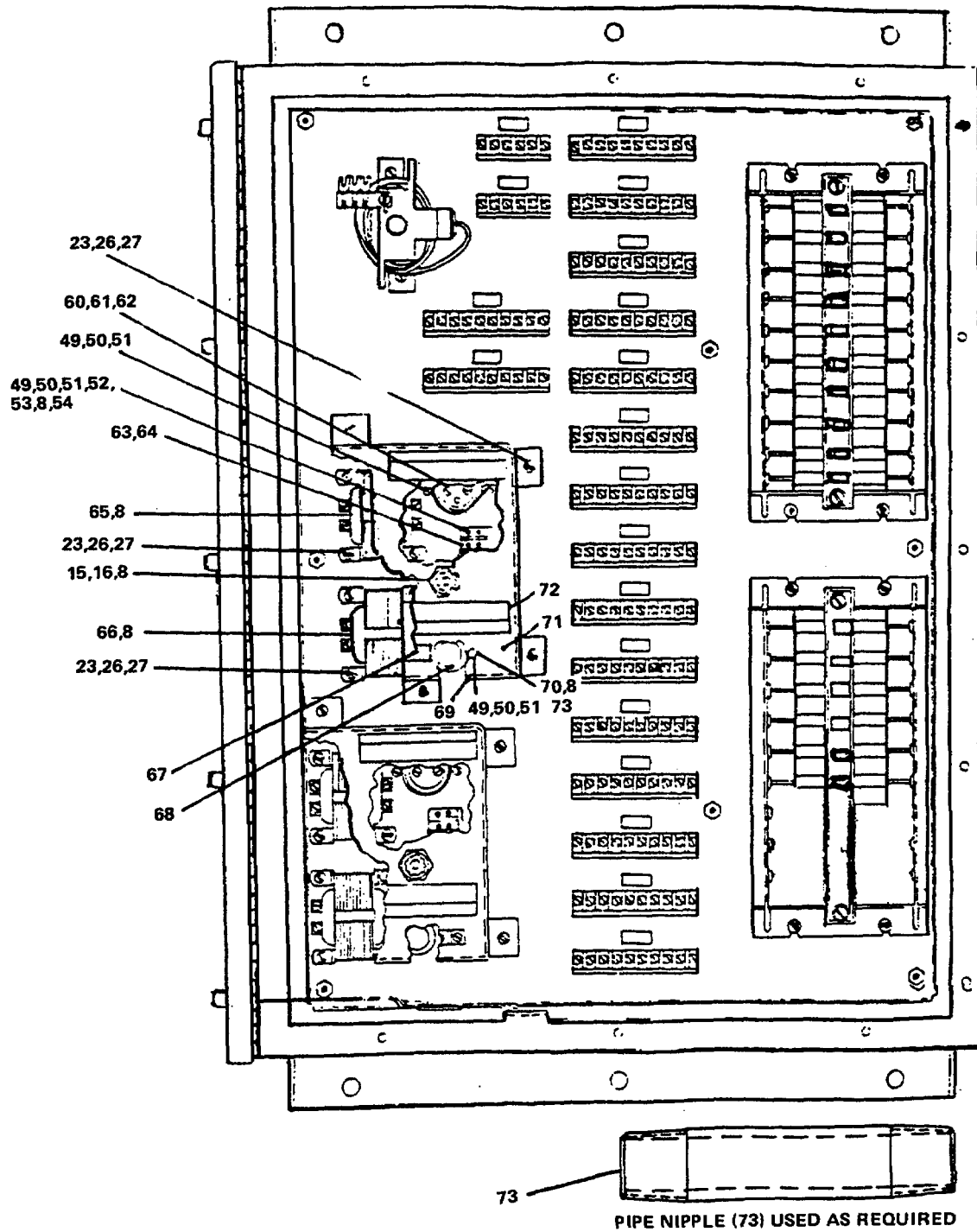

FIGURE 3-45. Receiver Module, RE-39260-12/MI-M8-38100/M9-M12-38139  
(Sheet 5 of 5).

(4) Repeat steps (1) through (3) to remove toggle switch (12).

g. Sonalert alarm.

(1) Tag electrical wires and clip wire ends at sonalert alarm (14).

(2) Remove terminal lug (8) and preformed packing (13) from front panel.

(3) Remove sonalert alarm (14) from rear of front panel.

h. Fuseholder.

(1) Tag electrical wires and clip wire ends at fuseholder (16).

(2) Remove terminal lug (8) at rear of fuseholder.

(3) Remove fuseholder (16) and fuse cartridge (15) from front panel.

i. Indicator light.

(1) Tag and disconnect electrical lead at rear of indicator light (17).

(2) Remove terminal lug (8) at rear of indicator light.

(3) Remove indicator light (17) and incandescent lamp (18) from front panel.

j. Card rack. (Figure 3-45, Sheet 2).

(1) Remove two hex head capscrews (29) and lockwashers (30) securing retaining bar (31) to card racks (28). Remove retaining bar.

(2) Remove identification markers (32) (9 places) from retaining bar (31).

(3) Remove power supply (33) and flasher module (34) circuit cards from card rack.

(4) Remove circuit card assembly (35).

(5) Remove four machine screws (36) and lockwashers (37) securing card guides (38) to sides of card rack (28).

(6) Remove card guides (38).

(7) Repeat steps (5) and (6) for remaining card guides.

(8) Tag and disconnect electrical leads to printed circuit connector (39).

(9) Remove two machine screws (36) and lockwashers (37) securing printed circuit connector (39) to card rack (28).

(10) Remove printed circuit connector.

(11) Repeat steps (8) through (10) to remove remaining printed circuit connectors (39).



(12) Remove four plain hex nuts (27), lockwashers (26), and machine screws (23) securing card rack (28) to rack mount.

(13) Remove card rack.

k. Simulator float. (Figure 3-45, Sheet 3).

(1) Remove identification plate (48) from simulator float (40).

(2) Remove wing nut (44) and release connecting strip (43).

(3) Unwind electrical cable (45) from simulator float.

(4) Disconnect snub bushing (59) from simulator float. Remove electrical cable.

(5) Remove two plain hex nuts (27), lockwashers (26), and machine screws (23) securing simulator float (40) to support mount.

(6) Remove simulator float, wire wound variable resistor (41), and knob (42).

(7) Remove terminal marker strip (47) from terminal block (46).

(8) Tag and disconnect electrical leads from wire hook-up (52).

(9) Disconnect cable ties (53) from cable harness.

(10) Remove terminal lug (8) securing tie mounting device (54) to support mount.

(11) Remove tie mounting device.

(12) Remove two plain hex nuts (51), lockwashers (50), and machine screws (49) securing terminal block (46) to support mount.

(13) Repeat steps (7) through (12) to remove terminal block (55) and terminal marker strips (56).

(14) Remove identification markers (56).

(15) Remove type-J jumpers (58).

l. Power supply. (Figure 3-45, Sheets 4 and 5).

(1) Unscrew and remove fuse cartridge (15) and fuse fuseholder (16) on cover plate.

(2) Remove four plain hex nuts (27), lockwashers (26), and machine screws (23) securing cover plate to support mounts.

(3) Position cover plate to expose fuseholder (16).

(4) Tag electrical wires and clip off wire ends at fuseholder.

- (5) Remove terminal lug (8) at rear of fuseholder.
- (6) Remove fuseholder from front of cover plate.
- (7) Remove cover plate.
- (8) Tag and disconnect leads from stud terminals (60) on electrolytic fixed capacitor (61).
- (9) Remove two plain hex nuts (51), lockwashers (50), and machine screws (49) securing shock pad (62) to support mount.
- (10) Remove shock pad and electrolytic fixed capacitor (61).
- (11) Remove terminal marker strip (64) from terminal block (63).
- (12) Tag and disconnect electrical leads from wire hook-up (52).
- (13) Disconnect cable ties (53) from cable harness.
- (14) Remove terminal lug (8) securing tie mounting device (54) to support mount.
- (15) Remove tie mounting device.
- (16) Remove two plain hex nuts (51), lockwashers (50), and machine screws (49) securing terminal block (63) to support mount.
- (17) Tag and disconnect electrical leads from power transformer (65) by removing four terminal lugs (8).
- (18) Remove four plain hex nuts (27), lockwashers (26), and machine screws (23) securing power transformer (65) to support mount.
- (19) Remove power transformer.
- (20) Repeat steps (17) through (19) to remove power transformer.
- (21) Remove identification markers (67) and (69).
- (22) Tag and disconnect electrical leads from terminal block (70).
- (23) Remove two plain hex nuts (51), lockwashers (50), and machine screws (49) securing terminal block (70) to support mount. Remove terminal block.
- (24) Pull electrical leads clear of nonmetallic grommet (68).
- (25) Remove nonmetallic grommet.

## REPAIR

Repair of receiver module RE-39240-7/M1-M7A-38100 consists of replacing gasket (21, 24), meter assembly (4), preformed packing (9, 13), toggle switch (10), (12), sonalert alarm (14), card guides (38), printed circuit connectors (39), power supply (33), flasher module (34), circuit card assembly (35), simulator float (40), variable wire wound resistor (41), knob (42), nonmetallic grommet (68), power transformers (65, 66), and electrolytic fixed capacitor (61).

## ASSEMBLY

- a. Position receiver module on a clean flat surface.
- b. Power supply. (Figure 3-45, Sheets 4 and 5).
  - (1) Install nonmetallic grommet (68).
  - (2) Run electrical leads through nonmetallic grommet.
  - (3) Position terminal block (70) on support mount.
  - (4) Install two machine screws (49), lockwashers (50), and plain hex nuts (51) and secure terminal block to support mount.
  - (5) Connect electrical leads to terminal block (70). Remove tags.
  - (6) Attach identification markers (69) and (67).
  - (7) Position power transformer (65) over support mount.
  - (8) Install four machine screws (23), lockwashers (26), and plain hex nuts (27) and secure power transformer (65) to support mount.
  - (9) Connect electrical leads to power transformer (65) using four terminal lugs (8). Remove tags.
  - (10) Repeat steps (7) through (9) to install power transformer (66).
  - (11) Position terminal block (63) over support mount.
  - (12) Install two machine screws (49) lockwashers (50) and plain hex nuts (51) and secure terminal block to support mount.
  - (13) Position tie mounting device (54) on support mount and secure tie mounting device using terminal lug (8).
  - (14) Connect cable ties (53) to cable harness.
  - (15) Connect electrical leads to wire hook-up (52). Remove tags.
  - (16) Attach terminal marker strip (64) to terminal block (63).

- (17) Position electrolytic fixed capacitor (61) into shock pad (62).
- (18) Install two machine screws (49), lockwashers (50), and plain hex nuts (51) and secure electrolytic fixed capacitor to support mount with shock pad (62).
- (19) Connect electrical leads to stud terminals (60) on electrolytic fixed capacitor (61). Remove tags.
- (20) Position fuseholder (16), with fuse cartridge (15) enclosed, into fuseholder mounting hole on cover plate.
- (21) Install terminal lug (8) at rear of fuseholder.
- (22) Install electrical wire ends on fuseholder (16). Remove tags.
- (23) Position cover plate over mounting screw holes.
- (24) Install four machine screws (23), lockwashers (26), and plain hex nuts (27) and secure cover plate to support mount.

c. Simulator float. (Figure 3-45, Sheet 3).

- (1) Install type-J jumpers (58).
- (2) Attach identification markers (57).
- (3) Position terminal block (46) on support mount.
- (4) Install two machine screws (49), lockwashers (50), and plain hex nuts (51) and secure terminal block (46) to support mount.
- (5) Position tie mounting device (54) on support mount.
- (6) Install terminal lug (8) and secure tie mounting device to support mount.
- (7) Connect cable ties (53) to cable harness.
- (8) Connect electrical leads to wire hook-up (52). Remove tags.
- (9) Attach terminal marker strip (47) to terminal block (46).
- (10) Repeat steps (3) through (9) to install terminal blocks (55) and terminal marker strips (56).
- (11) Position simulator float (40), wirewound variable resistor (41), and knob (42) over support mount.
- (12) Install two machine screws (23), lockwashers (26), and plain hex nuts (27) and secure simulator float (40) to support mount.
- (13) Connect snub bushing (59) on opposite end of electrical cable (45) to simulator float.

- (14) Wind electrical cable (45) clockwise onto simulator float.
- (15) Position connecting strip (43) on simulator float.
- (16) Install wing nut (44) and secure connecting strip to simulator float.
- (17) Attach identification plate (48) to simulator float.

d. Card rack. (Figure 3-45, Sheet 2).

- (1) Position card rack (28) over support mount.
- (2) Install four machine screws (23), lockwashers (26), and plain hex nuts(27) and secure card rack to support mount.
- (3) Position printed circuit connector (39) over support mount on card rack (28).
- (4) Install two machine screws (36) and lockwashers (37) and secure printed circuit connector (39) to support mount on card rack.
- (5) Connect electrical leads to printed circuit connector. Remove tags.
- (6) Repeat steps (3) through (5) to install remaining printed circuit connectors (39).
- (7) Position card guide (38) on each side of card rack (28).
- (8) Install two machine screws (36) and lockwashers (37) on each side of card rack and secure card guides to card rack.
- (9) Repeat steps (7) and (8) to install remaining card guides (38).
- (10) Install circuit card assemblies (35) into card rack (28).
- (11) Install flasher module (34) and power supply (33) circuit cards into card rack.
- (12) Attach identification markers (32) on retaining bar (31).
- (13) Position retaining bar (31) over card rack (28) with mounting screw holes aligned.
- (14) Install two hex head capscrews (29) and lockwashers (30) and secure retaining bar to card rack.

e. Indicator light. (Figure 3-45, Sheet 1).

- (1) Position indicator light (17) and incandescent lamp (18) on front panel.
- (2) Install terminal lug (8) at rear of indicator light.
- (3) Connect electrical leads at rear of indicator light (17). Remove tag.

f. Fuseholder.

- (1) Position fuseholder (16) and fuse cartridge (15) on front panel.
- (2) Install terminal lug (8) at rear of fuseholder.
- (3) Connect electrical wire ends to fuseholder. Remove tag.

g. Sonalert alarm.

- (1) Position sonalert alarm (14) at rear of front panel.
- (2) Install preformed packing (13) and terminal lug (8) on sonalert alarm at front panel.
- (3) Connect electrical wire ends to sonalert alarm. Remove tag.

h. Toggle switch.

- (1) Position toggle switch (10) at rear of front panel.
- (2) Install preformed packing (9) and terminal lug (8) on toggle switch at front panel.
- (3) Connect electrical wire ends to toggle switch. Remove tag.
- (4) Repeat steps (1) through (3) to install toggle switch (12).

i. Indicator light.

- (1) Attach identification plates (7) and identification plate (11) to front panel.
- (2) Position indicator light (5) on front panel.
- (3) Install terminal lug (8) at rear of indicator light.
- (4) Connect electrical leads; install insulating tubing (6) at rear of indicating light. Remove tag.
- (5) Repeat steps (2) through (4) to install remaining indicator lights.

j. Meter.

- (1) Position meter (4) on front panel.
- (2) Install four machine screws (1), lockwashers (2), and plain hex nuts (3) and secure meter to front panel.
- (3) Connect electrical leads to meter. Remove tags.
- (4) Repeat steps (1) through (3) to install remaining meters.

k. Front panel.

- (1) Install gasket (21) on box assembly (22).
- (2) Close front panel.
- (3) Install nine hexhead capscrews (19) and lockwashers (20) and secure front panel to box assembly (22).

1. Access panel.

- (1) Position gasket (24) and access panel (25) on bottom of box assembly (22).
- (2) Install 10 machine screws (23) and lockwasher (20) and secure access panel to box assembly.
- (3) Repeat steps (1) and (2) to install access panel at top of box assembly.

**REPLACEMENT** (Figure 3-44)

- a. Position box assembly (4) over support mount with mounting screw holes aligned.
- b. Install six hex head capscrews (1), lockwasher (2), and plain hex nuts (3) and secure box assembly to support mount.
- c. Connect electrical cable connectors at top of box assembly. Remove tags.
- d. Turn on electrical power at panel L102. Remove tags.

---

**3-46. Replace/Repair Receiver Module RE-31326. (Figure 3-46)**

---

**This task covers:**

- |                        |                       |
|------------------------|-----------------------|
| <b>a. Removal</b>      |                       |
| <b>b. Disassembly,</b> | <b>d. Assembly,</b>   |
| <b>c. Repair</b>       | <b>e. Replacement</b> |
- 

**INITIAL SETUP****Tools**

Tool kit, general mechanic's,  
5180-00-699-5273

**Materials/Parts**

Gasket P/N 31407, 28736, 16600 (3)  
Meter P/N 15032  
Dust and moisture seal boot  
P/N 36805  
Wirewound variable resistor  
P/N RV4SAYSB252A  
Power supply P/N 41415  
Power transformer P/N 37031  
Electrical receptacle connector  
P/N 10626  
Insulating tubing P/N 26657 (3)  
Receptacle plug P/N 28107, 28109  
Warning tags, Item 1, Appendix C

**Equipment Condition**

Electrical power to tank level  
indicator system turned OFF  
at Panel L102. Tag switch  
"Out of Service - Do Not  
Operate."

---

**REMOVAL**

- a. Electrical receptacle connector (39) and receptacle plugs (45, 49).
  - (1) Tag and disconnect electrical receptacle connector (39) from electrical receptacle (38).
  - (2) Tag and disconnect receptacle plug (45) from electrical receptacle (44).
  - (3) Tag and disconnect receptacle plug (49) from electrical receptacle (48).
- b. Remove four plain hex nuts (7), lockwashers (6), flat washers (5), and machine bolts (4) securing mounting rack (55) to the support mount.
- c. Remove mounting rack/receiver module from the support mount.
- d. Position mounting rack on a clean flat surface.
- e. Remove four machine screws (1), lockwashers (2), and flat washers (3) securing receiver module in mounting rack (55).



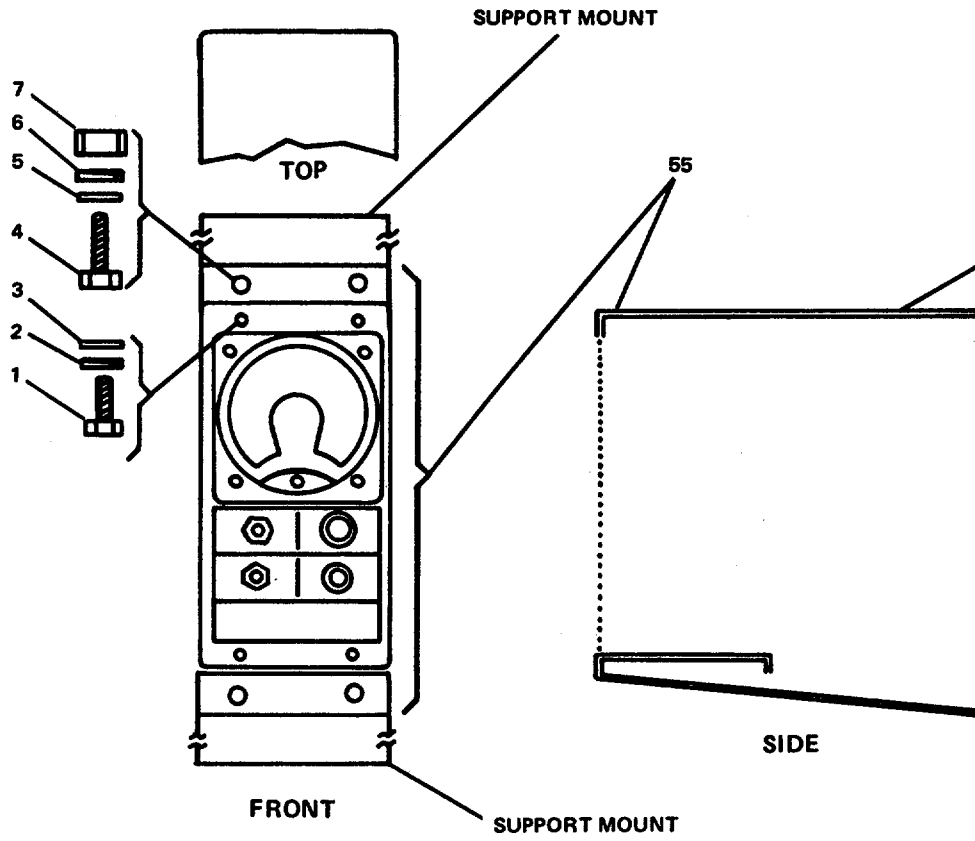

FIGURE 3-46. *Receiver Module, RE-31326 (Sheet 1 of 2).*

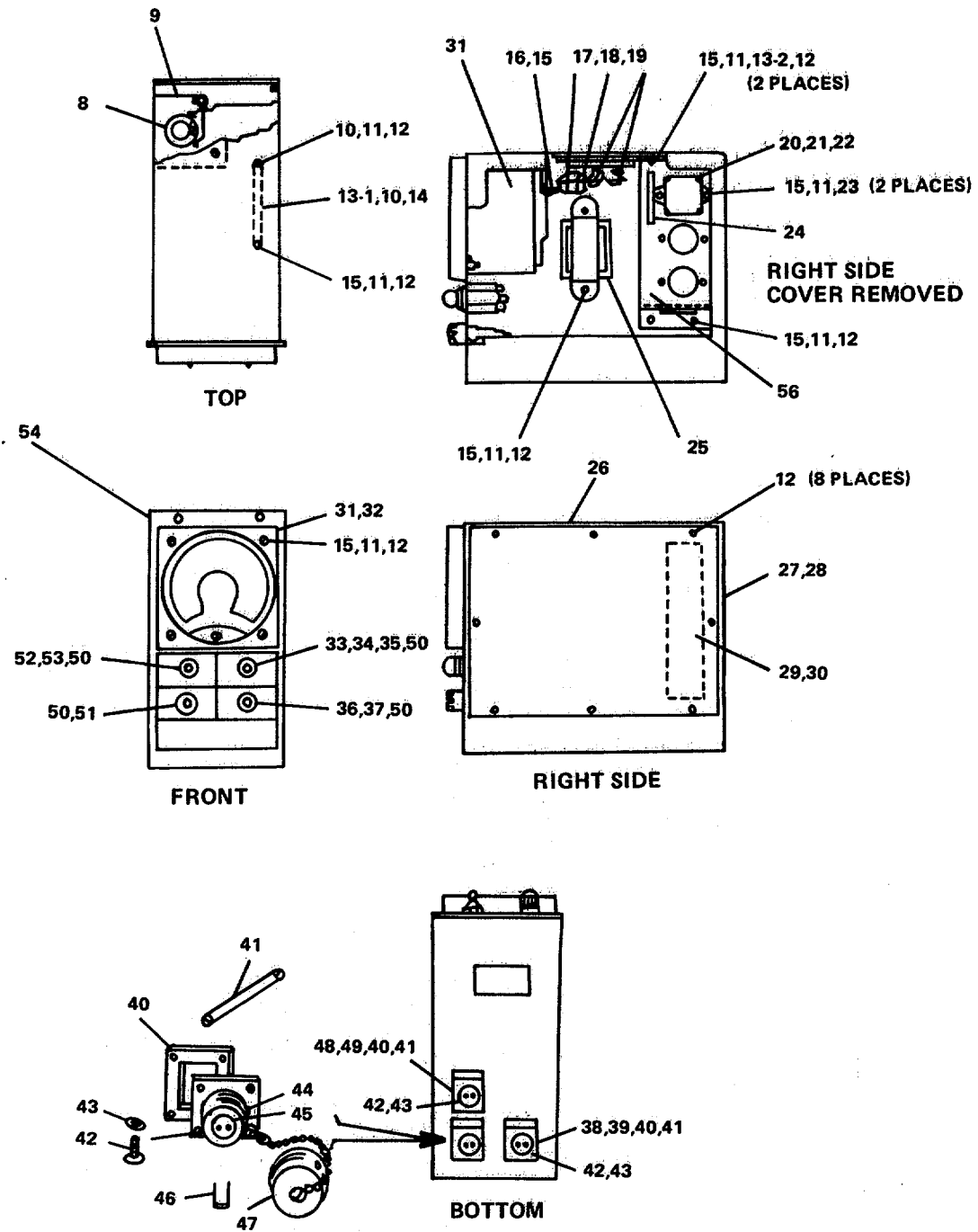

FIGURE 3-46. Receiver Module, RE-31326 (Sheet 2 of 2).

- f. Remove receiver module from mounting rack.

**DISASSEMBLY**

- a. Position receiver module silk screened box (26) on clean, flat surface.

- b. Cover (27).

- (1) Remove eight machine screws (12) from cover (27) on right side of silk screened box.

- (2) Remove cover (27) and cover gasket (28).

- c. Remove shock cushion (29) and adhesive (30) from cover (27).

- d. Meter (31).

- (1) Tag and disconnect electrical leads by removing two plain hex nuts (15) from terminal studs (16) at rear of meter (31).

- (2) Remove four plain hex nuts (15), lockwashers (11), and machine screws (12) securing meter (31) at front panel.

- (3) Remove meter (31) and gasket (32).

- e. Toggle switch (53).

- (1) Tag and disconnect electrical leads at rear of toggle switch (53).

- (2) Remove locking nut (50) from toggle switch (53).

- (3) Remove dust and moisture seal boot (52) and toggle switch from rear of front panel.

- f. Wirewound variable resistor (51).

- (1) Tag and disconnect electrical leads at rear of wirewound variable resistor (51).

- (2) Remove locking nut (50) from variable resistor (51).

- (3) Remove wirewound variable resistor (51) from rear of front panel.

- g. Fuseholder (36).

- (1) Tag and disconnect electrical leads at rear of fuseholder (36).

- (2) Remove locking nut (50) from fuseholder (36).

- (3) Remove alarm control fuse (36) and fuseholder (36) from rear of front panel.

h. Indicator light (33).

- (1) Tag and disconnect electrical leads and electrical insulation sleeving (34) at rear of indicator light (33).
- (2) Remove locking nut (50) from indicator light (33).
- (3) Remove indicator light (33) and neon lamp (35) from rear of front panel.

i. Terminal strip (13-2).

- (1) Tag and disconnect electrical leads from terminal strip (13-2).
- (2) Remove two plain hex nuts (15), lockwashers (11), and machine screws (12) from terminal strip (13-2).
- (3) Remove terminal strip.

j. Terminal strip (13-1).

- (1) Tag and, using a soldering iron, unsolder electrical wires and hook-up wires (14) from terminal strip (13-1).
- (2) Remove two plain hex nuts (15), lockwashers (11), and machine screws (12) from terminal strip (13-1).
- (3) Remove terminal strip.

k. Cable tie (10).

- (1) Remove machine screw (12) and lockwashers (11) from cable tie (10).
- (2) Remove cable tie (10).

l. Capacitor (17).

- (1) Tag and, using a soldering iron, unsolder wire leads from capacitor (17).
- (2) Remove capacitor.

m. Resistors (18, 19).

- (1) Tag and, using a soldering iron, unsolder wire leads from resistors (18) and (19).
- (2) Remove resistor (18) and resistors (19).

n. Power supply (20).

- (1) Remove by pulling power supply (20) out of power supply socket (21).
- (2) Remove two plain hex nuts (15), lockwashers (11), and machine screws (23) from power supply socket (21).

- (3) Lift power supply socket to expose electrical wires. Tag and, using a soldering iron, unsolder electrical wires from power supply socket (21).
- (4) Remove power supply socket.
- (5) Remove four plain hex nuts (15), lockwashers (11), and machine screws (12) from bracket (56).
- (6) Remove bracket.
- (7) Remove identification marker (24) from bracket.

o. Power transformer (25).

- (1) Remove four plain hex nuts (15), lockwashers (11), and machine screws (12) from power transformer (25).
- (2) Lift power transformer to expose electrical wires.
- (3) Tag and, using a soldering iron, unsolder electrical wires from power transformer.
- (4) Remove power transformer (25).

p. Electrical receptacle (38).

**NOTE**

Electrical receptacle connector (3 pin plug) disconnected during removal procedure.

- (1) Remove four flathead screws (42) and lockwashers (43) from electrical receptacle (38).
- (2) Lift electrical receptacle (38) to expose electrical wires.
- (3) Tag and, using a soldering iron, unsolder electrical wires from electrical receptacle.
- (4) Remove electrical receptacle (38), gasket (40) and insulating tubing (41).

q. Electrical receptacle (44).

**NOTE**

Receptacle plug (2 pin plug) disconnected during removal procedure.

- (1) Remove four flat head screws (42) and lockwashers (43) from electrical receptacle (44).
- (2) Lift electrical receptacle (44) to expose electrical wires.

- (3) Tag and, using a soldering iron, unsolder electrical wires from electrical receptacle.
- (4) Remove electrical receptacle (44), gasket (40) and insulating tubing (41).
- (5) Remove jumper wire (46) and protective cap (47) from electrical receptacle (44).

r. Electrical receptacle (48).

#### NOTE

Receptacle plug (2 socket plug) disconnected during removal procedure.

Repeat steps p.(l) through (4) to remove electrical receptacle (48).

s. Grommet (8).

- (1) Pull electrical wiring and cable harnesses clear of grommet (8).
- (2) Remove grommet from bracket (9).

#### REPAIR

Repair of receiver module consists of replacing gaskets (28, 32, 40) 3-places, meter (31), dust and moisture seal boot (52), wirewound variable resistor (51), power supply (20), power transformer (25), electrical receptacle connector (39), insulating tubing (41) 3-places, receptacle plug (45, 49).

#### ASSEMBLY

a. Position receiver module silk screened box (26) on a clean flat surface.

b. Grommet (8).

- (1) Install grommet on bracket (9).
- (2) Direct electrical wiring and cable harnesses through grommet (8).

c. Electrical receptacle (48).

- (1) Position gasket (40) and electrical receptacle (48) over mounting hole with electrical wires exposed.
- (2) Install insulating tubing (41) on electrical wires.
- (3) Connect by soldering electrical wires to electrical receptacle (48). Remove tags.
- (4) Lower electrical receptacle and gasket over mounting screw holes on silk screened box (26).

- (5) Install four lockwashers (43) and flat head screws (42) and secure electrical receptacle to bottom of silk screened box.

**NOTE**

Receptacle plug (2 socket plug) connected during replacement procedure.

d. Electrical receptacle (44).

- (1) Position gasket (40) and electrical receptacle (44) over mounting hole with electrical wires exposed.
- (2) Install insulating tubing (41) on electrical wires.
- (3) Connect by soldering electrical wires to electrical receptacle (44). Remove tags.
- (4) Lower electrical receptacle and gasket over mounting screw holes on silk screened box (26).
- (5) Install four lockwashers (43) and flathead screws (42) and secure electrical receptacle to bottom of silk screened box.
- (6) Install jumper wire (46) and protective cap (47) on electrical receptacle (44).

**NOTE**

Receptacle plug (2 pin plug) connected during replacement procedure.

e. Electrical receptacle (38).

Repeat steps c.(l) through (5) to install electrical receptacle (38).

**NOTE**

Electrical receptacle connector (3 pin plug) connected during replacement procedure.

f. Power transformer (25).

- (1) Position power transformer over exposed electrical wires.
- (2) Connect by soldering electrical wires to power transformer (25). Remove tags.
- (3) Position power transformer over mounting screw holes.
- (4) Install four machine screws (12), lockwashers (11), and plain hex nuts and secure power transformer to support mount.

g. Power supply (20).

- (1) Attach identification marker (24) to bracket (56).
- (2) Position bracket (56) over support mount with electrical wires exposed.
- (3) Install four machine screws (12), lockwashers (11), and plain hex nuts (15) and secure bracket to support mount.
- (4) Position power supply socket (21) over exposed electrical wires.
- (5) Connect by soldering electrical wires to power supply socket (21). Remove tags.
- (6) Position power supply socket over mounting screw holes.
- (7) Install two machine screws (23), lockwashers (11), and plain hex nuts (15) and secure power socket to support mount.
- (8) Install power supply (20) into power supply socket (21).

h. Resistors (18, 19).

- (1) Connect by soldering wire leads to resistor (18).
- (2) Connect by soldering wire leads to resistor (19).
- (3) Remove tags.

i. Capacitor (17).

- (1) Connect by soldering wire leads to capacitor (17).
- (2) Remove tags.

j. Cable tie (10).

- (1) Position cable tie (10) over support mount.
- (2) Install lockwashers (11) and machine screws (12) and secure cable tie to support mount.

k. Terminal strip (13-1).

- (1) Position terminal strip over mounting screw holes.
- (2) Install two machine screws (12), lockwashers (11), and plain hex nuts (15) and secure terminal strip to support mount.
- (3) Connect by soldering electrical wires and hook-up wires (14) to terminal strip (13-1).



1. Terminal strip (13-2).

- (1) Position terminal strip over mounting screw holes.
- (2) Install two machine screws (12), lockwashers (11), and plain hex nuts (15) and secure terminal strip to support mount.
- (3) Connect by soldering electrical wires and hook-up wires (14) to terminal strip (13-2).

m. Indicator light (33).

- (1) Install neon lamp (35) and indicator light (33) from rear of front panel.
- (2) Install locking nut (50) on indicator light.
- (3) Install electrical insulation sleeving (34) over electrical leads.
- (4) Connect electrical leads to indicator light at rear of front panel. Remove tags.

n. Fuseholder (36).

- (1) Install alarm control fuse (37) and fuseholder (36) from rear of front panel.
- (2) Install locking nut (50) on fuseholder.
- (3) Connect electrical leads to fuseholder at rear of front panel.

o. Wirewound variable resistor (51).

- (1) Install wirewound variable resistor (51) from rear of front panel.
- (2) Install locking nut (50) on variable resistor (51).
- (3) Connect electrical leads to variable resistor at rear of front panel. Remove tags.

p. Toggle switch (53).

- (1) Install toggle switch (53) and dust and moisture seal boot (52) from rear of front panel.
- (2) Install locking nut (50) on toggle switch.
- (3) Connect electrical leads to toggle switch at rear of front panel. Remove tags.

q. Meter (31).

- (1) Install gasket (32) and meter (31) on front panel.

- (2) Install four machine screws (12), lockwashers (11), and plain hex nuts (15) and secure meter to front panel.
  - (3) Connect electrical leads to meter by installing two plain hex nuts (15) on terminal studs (16) at rear of meter (31).
  - (4) Remove tags.
- r. Apply adhesive (30) and attach shock cushion (29) on cover (27).
- s. Cover (27).
- (1) Position cover gasket (28) and cover (27) over mounting screw holes on right side of silk screened box.
  - (2) Install eight machine screws (12) and secure cover to silk screened box.

## REPLACEMENT

- a. Position mounting rack (55) on a clean flat surface.
- b. Install receiver module into mounting rack.
- c. Install four machine screws (1) with lockwashers (2) and flatwasher (3) and secure receiver module to mounting rack.
- d. Position mounting rack (55) with receiver module over mounting bolt holes on support rack.
- e. Install four machine bolts (4), flat washers (5), lockwashers (6), and plain hex nuts (7) and secure mounting rack to support mount.
- f. Electrical receptacle connector (39) and receptacle plugs (45, 4.9).
  - (1) Connect electrical receptacle connector (39) to electrical receptacle (38). Remove tag.
  - (2) Receptacle plug (45).
    - (a) Remove protective cap (47) and jumper wire (46).
    - (b) Connect receptacle plug (45) to electrical receptacle (44).
  - (3) Connect receptacle plug (49) to electrical receptacle (48). Remove tag.
- g. Restore electrical power to tank level indicator systems at panel L102. Remove tag.

<b>MAINTENANCE OF NAVIGATION SIGNALS AND SEARCHLIGHTS</b>
---

---

**3-47. Replace/Repair Searchlight. (Figure 3-47)**

---

This task covers:

a. Removal

b. Repair,

c. Replacement

---

INITIAL SETUP

Tools

Tool kit, general mechanic's,  
5180-00-699-5273  
Tool kit, electrician's,  
5180-00-391-1087

Equipment Condition

Shut down electrical power at navigation light panel. Tag "Out of Service - Do Not Operate."

Materials/Parts

Warning tags, Item 1, Appendix C

---

**REMOVAL**

**WARNING**

High pressures exist inside lamp, especially when hot, and could explode. Handle lamp only in its protective cover.

Protect eyes and wear gloves when handling lamp.

Avoid direct or reflected radiation from the lamp.

Do not stand close in front of searchlight. Cover glass when lamp is lighted.

- a. Tag and disconnect electrical leads.
- b. Remove mounting bolts (2) from searchlight base (3).
- c. Remove searchlight (1) from vessel deck (4).

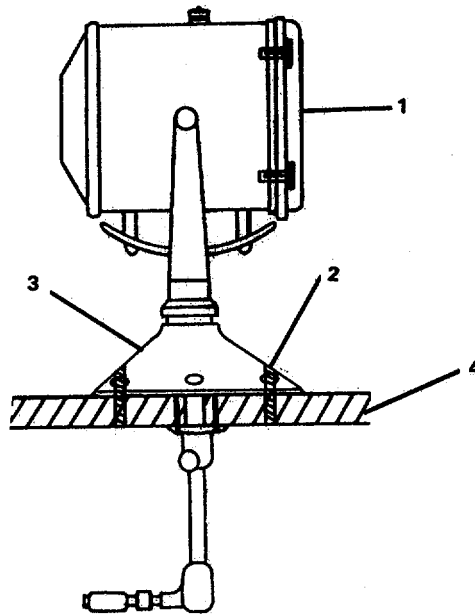

FIGURE 3-47. *Replace/Repair Searchlight.*

## REPAIR

Repair of the searchlight is by replacement/repair of the searchlight components. Refer to paragraphs 3-48 through 3-53.

## REPLACEMENT

- a. Install searchlight (1) on vessel deck (4).
- b. Install mounting bolts (2) into searchlight base (3).
- c. Remove tags and connect electrical leads.
- d. Remove tag and turn on electrical power at navigation light panel.

---

**3-48. Replace/Repair Drum Assembly.**

---

**This task covers:**

- |              |                 |           |
|--------------|-----------------|-----------|
| a. Removal   | b. Disassembly, | c. Repair |
| b. Assembly, | e. Replacement. |           |
- 

**INITIAL SETUP****Tools**

Tool kit, general mechanic's,  
5180-00,699-5273  
Tool kit, electrician's,  
5180-00-391-1087  
Lamp wrench P/N 9871

**Equipment Condition**

Shut down electrical power at  
navigation light panel. Tag "Out  
of Service - Do Not Operate."

**Materials/Parts**

Gasket P/N SL3110  
Xenon lamp P/N 19800  
Gasket P/N 19291  
Preformed packing P/N 12285K  
Preformed packing P/N 12285AA  
Preformed packing P/N 1266A  
Switch P/N 19723  
Sealing compound P/N 19669  
Warning tags, Item 1, Appendix C

---

**REMOVAL****WARNING**

High pressures exist inside lamp, especially when hot, and could explode. Handle lamp only in its protective cover.

Protect eyes and wear gloves when handling lamp.

Avoid direct or reflected radiation from the lamp.

Do not stand close in front of searchlight. Cover glass when lamp is lighted.

- a. Tag and disconnect electrical leads.
- b. Remove hexagon capscrew (6, Figure 3-48), lockwasher (5), and flat washer (4).

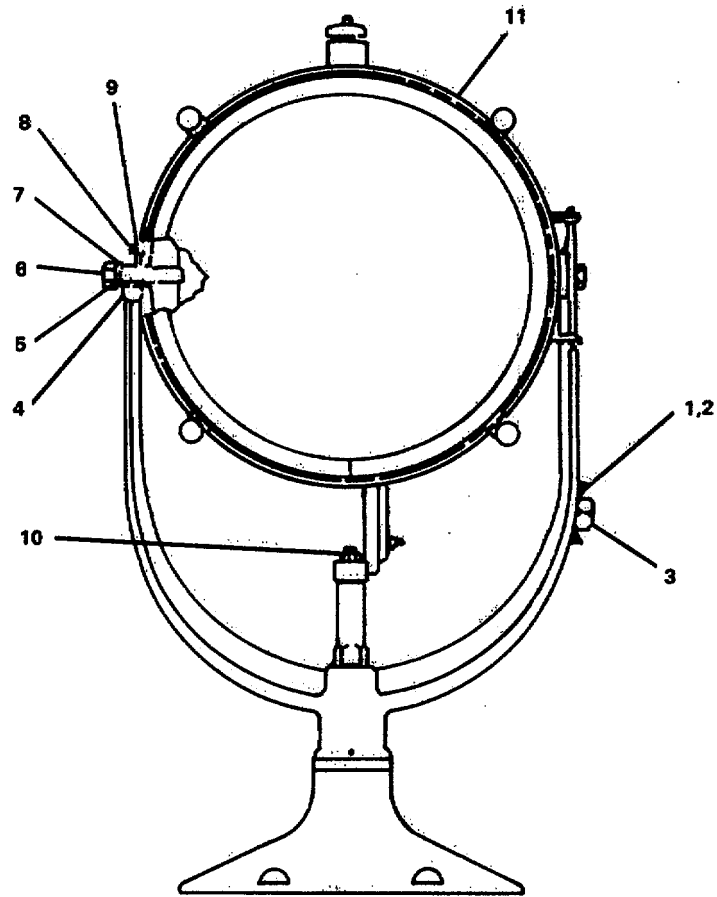

FIGURE 3-48. Drum Assembly Replacement.

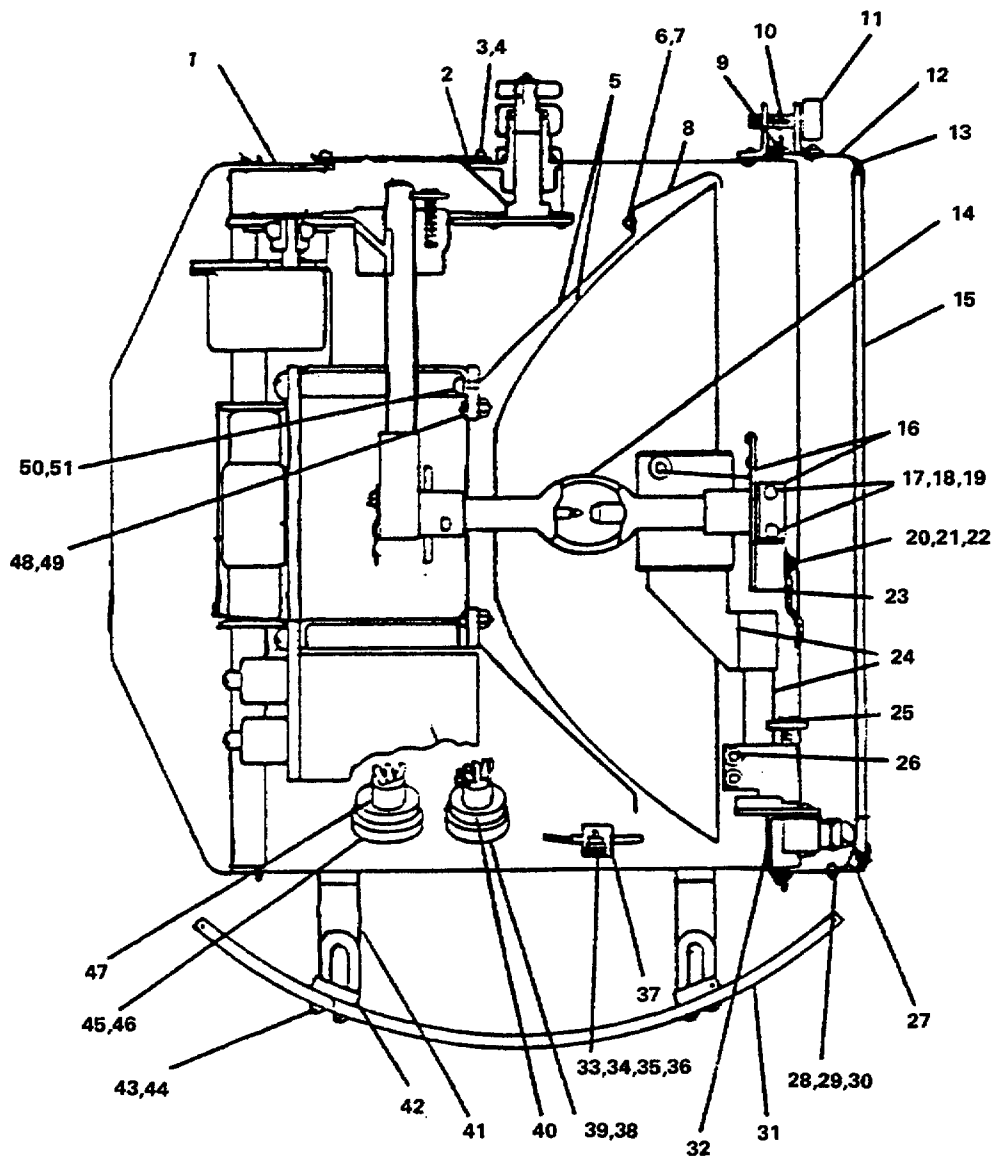

FIGURE 3-49. *Replace/Repair Drum Assembly (Sheet 1 of 4).*

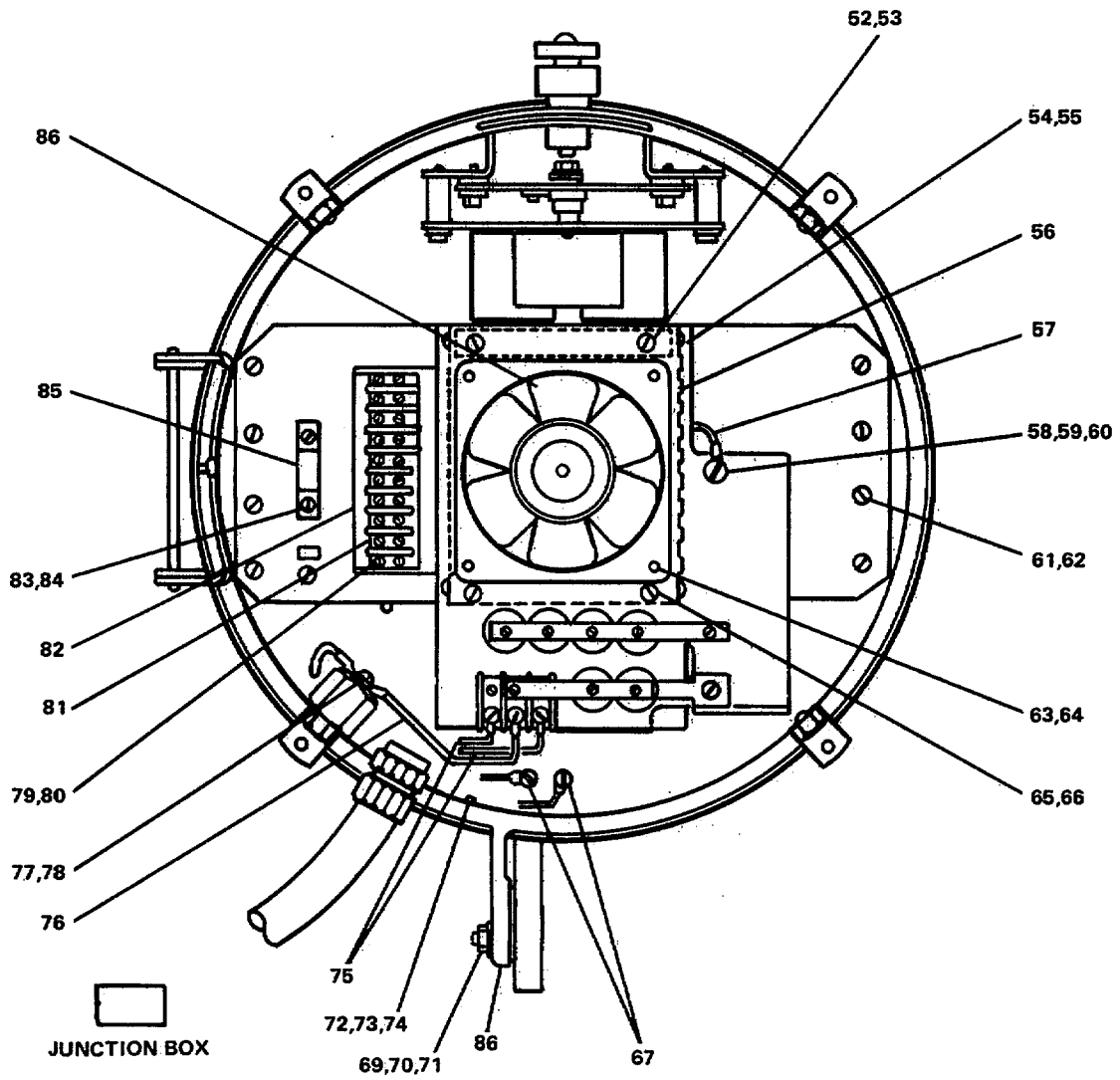

FIGURE 3-49. *Replace/Repair Drum Assembly (Sheet 2 of 4).*



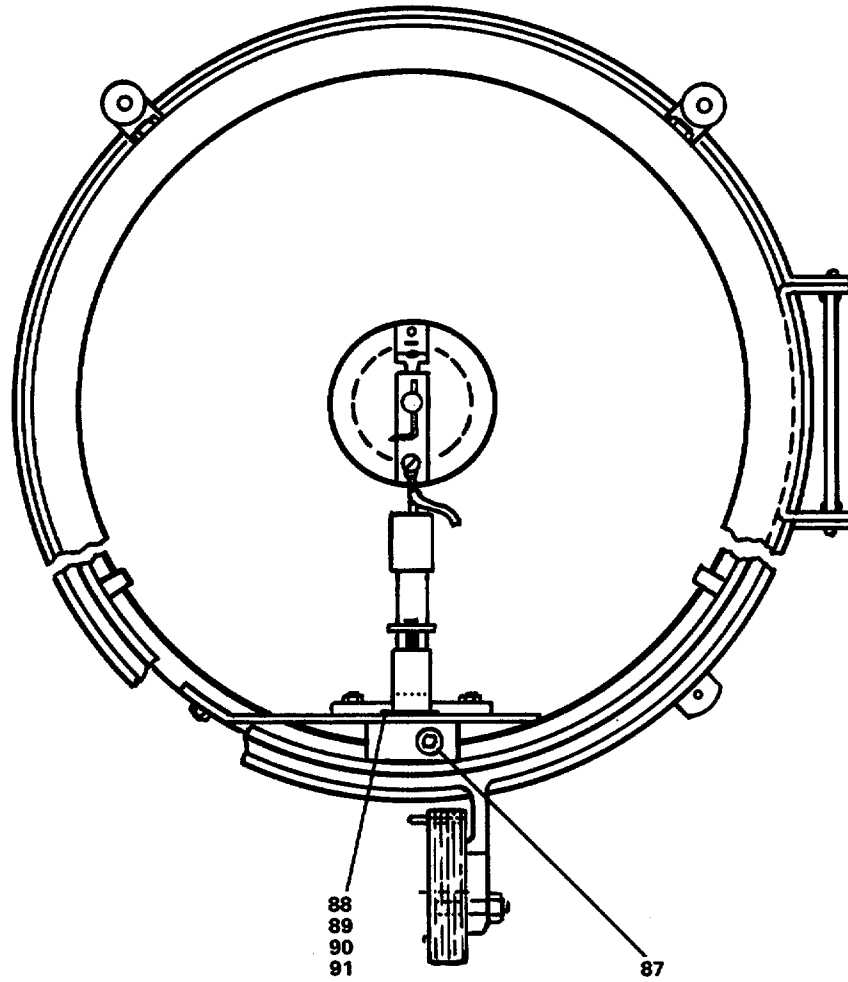

FIGURE 3-49. *Replace/Repair Drum Assembly (Sheet 3 of 4).*

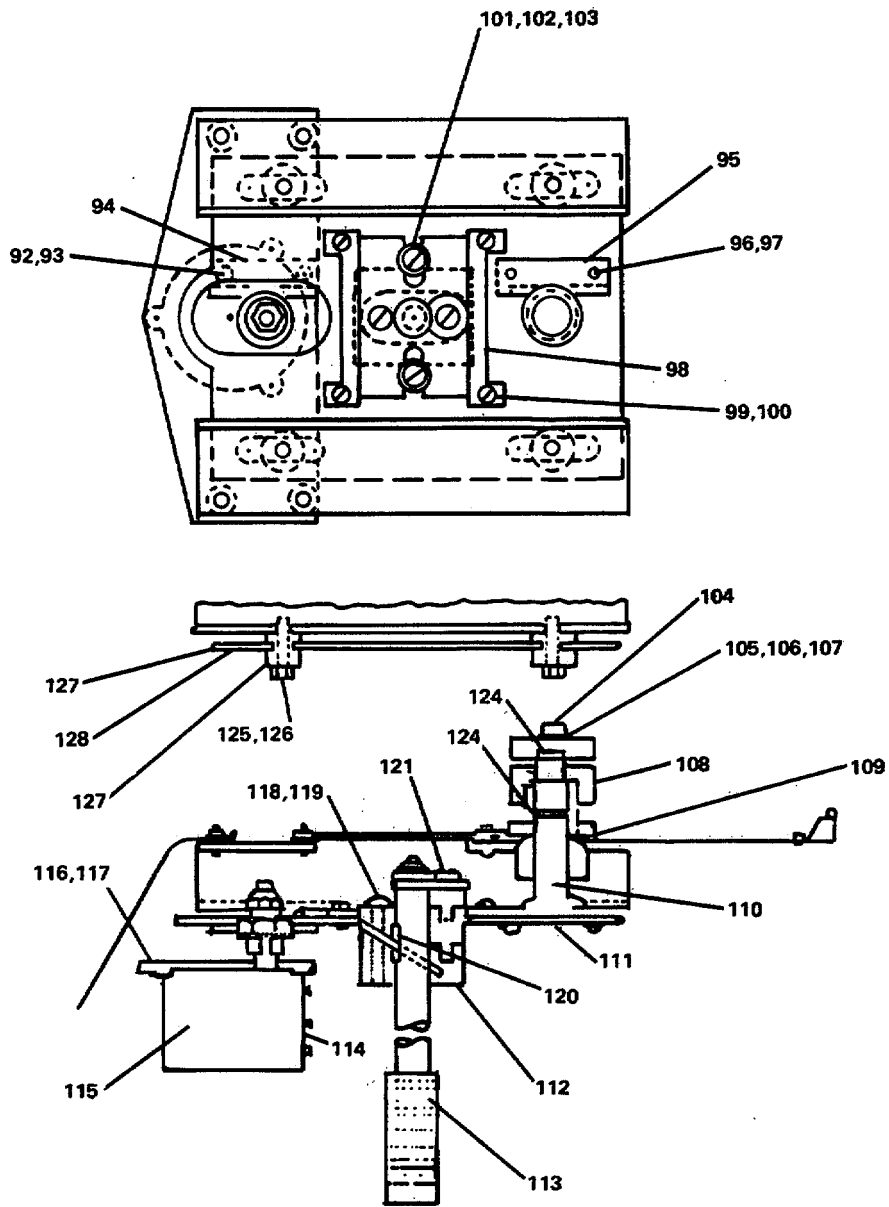

FIGURE 3-49. *Replace/Repair Drum Assembly (Sheet 4 of 4).*

- c. Remove bearing (7), spacer (9), and lubrication fitting (8).
- d. Remove machine screw (1), lockwasher (2), and clamp (3).
- e. Remove headless straight pin (10).
- f. Remove drum assembly (11).

## DISASSEMBLY

- a. Remove machine screw (11, Figure 3-49, Sheet 1) and flat washer (10).
- b. Open access cover (12).
- c. Remove gasket (9).
- d. Remove plain hexagon nut (26).
- e. Remove machine screw (29), lockwasher (28), and retaining clamp (30).
- f. Remove machine screw (25).
- g. Remove sealing compound (13).
- h. Remove lamp cover (15).
- i. Remove machine screw (17), lockwasher (18), and flat washer (19).
- j. Remove lamp support (24).
- k. Remove lamp socket (16).
- 1. Using lamp wrench, remove xenon lamp (14).
- m. Remove machine screw (48) and lockwasher (49).
- n. Remove machine screw (50) and lockwasher (51).
- o. Remove light reflector (5).
- p. Remove machine screw (6) and lockwasher (7).
- q. Remove angle bracket (8).
- r. Remove machine screw (96, Figure 3-49, Sheet 4) and lockwasher (97).
- s. Remove rack (95).
- t. Remove machine screw (99) and lockwasher (100).
- u. Remove guide (98).
- v. Remove machine screw (101), lockwasher (102), and flat washer (103).

- w. Remove hexagon capscrew (125) and lockwasher (126).
- x. Remove sleeve bushing (127).
- y. Remove teflon washer (128) and flat washer (129).
- z. Remove machine screw (118) and lockwasher (119).
- aa. Remove key (120).
- ab. Remove machine screw (121).
- ac. Remove machine screw (3, Figure 3-49, Sheet 1) and lockwasher (4).
- ad. Remove access cover (2).
- ae. Remove gasket (1).
- af. Remove machine screw (105, Figure 3-49, Sheet 4), lockwasher (106), and flat washer (107).
- ag. Remove machine key (124).
- ah. Remove focus knob (104).
- ai. Remove electronic compartment dial-knob lock (108).
- aj. Remove preformed packings (121, 122).
- ak. Remove plain hexagon nut (109).
- al. Remove spur gearshaft (110).
- am. Remove carriage (111).
- an. Remove clamp (112).
- ao. Remove socket (113).
- ap. Remove machine screw (92) and lockwasher (93).
- aq. Remove rack (94).
- ar. Remove machine screw (116) and lockwasher (117).
- as. Remove motor shield (114) and control motor (115).
- at. Remove machine screw (63, Figure 3-49, Sheet 2) and lockwasher (64).
- au. Remove machine screw (65) and lockwasher (66).
- av. Remove circulating fan (86).
- aw. Remove machine screw (83) and lockwasher (84).
- ax. Remove electrical component tie-down strap (85).

- ay. Remove machine screw (79) and lockwasher (80).
- az. Remove terminal board (82).
- ba. Remove insulator (81).
- bb. Remove machine screw (77) and lockwasher (78).
- bc. Remove electrical leads (67, 75, 76).
- bd. Remove machine screw (72), lockwasher (73), and flat washer (74).
- be. Remove plain hexagon nut (69), lockwasher (70), and flat washer (71).
- bf. Remove bracket (68).
- bg. Remove machine screw (61) and lockwasher (62).
- bh. Remove machine screw (52) and lockwasher (53).
- bi. Remove machine screw (54) and lockwasher (55).
- bj. Remove access cover (56).
- bk. Remove machine screw (58), flat washer (59), and lockwasher (60).
- bl. Remove electrical lead (57).
- bm. Remove machine screw (22, Figure 3-49, Sheet 1), lockwasher (21), and flat washer (20).
- bn. Remove electrical lead (23).
- bo. Remove machine screw (26).
- bp. Remove insulation (33).
- bq. Remove electrical power cable assembly (40).
- br. Remove Preformed packing (38) and stuffing tube (39).
- bs. Remove cable assembly (47).
- bt. Remove Preformed packing (45) and stuffing table (46).
- bu. Remove machine screw (43) and lockwasher (44).
- bv. Remove rack (31).
- bw. Remove clamp bolt assembly (42).
- bx. Remove rack bracket (41).
- by. Remove plain hexagon nut (33), lockwasher (34), flat washer (35), and machine screw (36).

- bz. Remove strap (37).
- ca. Remove double nut (88, Sheet 3), machine screw (89), lockwasher (90), and flat washer (91).
- cb. Remove switch (87).

## REPAIR

Repair at this level of maintenance is by the replacement of gaskets (1, 9, Figure 3-49, Sheet 1), Preformed packings (45, Figure 3-49, Sheet 1) and (121, 122, Figure 3-49, Sheet 4), switch (87, Figure 3-49, Sheet 3), xenon lamp (14, Figure 3-49, Sheet 1).

## ASSEMBLY

- a. Install switch (87, Figure 3-49, Sheet 3).
- b. Install flat washer (91), lockwasher (90), machine screw (89), and double nut (88).
- c. Install strap (37, sheet 1).
- d. Install machine screw (36), flat washer (35), lockwasher (34), plain hexagon nut (33).
- e. Install rack bracket (41).
- f. Install clamp bolt assembly (42).
- g. Install rack (31).
- h. Install lockwasher (44) and machine screw (43).
- i. Install stuffing tube (46) and Preformed packing (45).
- j. Install cable assembly (47).
- k. Install stuffing tube (39) and preformed packing (38).
- l. Install electrical power cable assembly (40).
- m. Install insulation (33).
- n. Install machine screw (26).
- o. Install electrical lead (23).
- p. Install flat washer (20), lockwasher (21), and machine screw (22).
- q. Install electrical lead (57, Figure 3-49, Sheet 2).
- r. Install lockwasher (60), flat washer (59), and machine screw (58).

- s. Install access cover (56).
- t. Install lockwasher (55) and machine screw (54).
- u. Install lockwasher (53) and machine screw (52).
- v. Install lockwasher (62) and machine screw (61).
- w. Install bracket (68).
- x. Install flat washer (71), lockwasher (70), and plain hexagon nut (69).
- y. Install flat washer (74), lockwasher (73), and machine screw (72).
- z. Install electrical leads (67, 75, 76).
- aa. Install lockwasher (78) and machine screw (77).
- ab. Install insulator (81);
- ac. Install terminal board (82).
- ad. Install lockwasher (80) and machine screw (79).
- ae. Install electrical component tie-down strap (85).
- af. Install lockwasher (84) and machine screw (83).
- ag. Install circulating fan (86).
- ah. Install lockwasher (66) and machine screw (65).
- ai. Install lockwasher (64) and machine screw (63).
- aj. Install control motor (115, Sheet 4) and motor shield (114).
- ak. Install lockwasher (117) and machine screw (116).
- al. Install rack (94).
- am. Install lockwasher (93) and machine screw (92).
- an. Install socket (113).
- ao. Install clamp (112).
- ap. Install carriage (111).
- aq. Install spur gearshaft (110).
- ar. Install plain hexagon nut (109).
- as. Install preformed packing (121, 122).
- at. Install electronic compartment dial-knob lock (108).

- au. Install focus knob (104).
- av. Install machine key (124).
- aw. Install flat washer (107), lockwasher (106), and machine screw (105).
- ax. Install gasket (1, Sheet 1).
- ay. Install access cover (2).
- az. Install lockwasher (4) and machine screw (3).
- ba. Install machine screw (121, Figure 3-49, Sheet 4).
- bb. Install key (120).
- bc. Install lockwasher (119) and machine screw (118).
- bd. Install flat washer (129) and teflon washer (128).
- be. Install sleeve bushing (127).
- bf. Install lockwasher (126) and hexagon capscrew (125).
- bg. Install flat washer (103), lockwasher (102), and machine screw (101).
- bh. Install guide (98).
- bi. Install lockwasher (100) and machine screw (99).
- bj. Install rack (95).
- bk. Install lockwasher (97) and machine screw (96).
- bl. Install angle bracket (8, Figure 3-49, Sheet 1).
- bm. Install lockwasher (7) and machine screw (6).
- bn. Install light reflector (5).
- bo. Install lockwasher (51) and machine screw (50).
- bp. Install lockwasher (49) and machine screw (48).

**CAUTION**

Do not touch quartz (glass) portion of lamp. Body chemicals will accelerate deterioration of lamp. Handle lamp in its cover until lamp is in lamp.

- bq. Using lamp wrench, install xenon lamp (14).
- br. Install lamp socket (16).



- bs. Install lamp support (24).
- bt. Install flat washer (19), lockwasher (18), and machine screw (17).
- bu. Install lamp cover (15).
- bv. Install sealing compound (13).
- bw. Install machine screw (25).
- bx. Install retaining clamp (30), lockwasher (28), and machine screw (29).
- by. Install plain hexagon nut (26).
- bz. Install gasket (9).
- ca. Close access cover (12).
- cb. Install flat washer (10) and machine screw (11).

#### **REPLACEMENT**

- a. Install drum assembly (11, Figure 3-48).
- b. Install headless straight pin (10).
- c. Install machine screw (1), lockwasher (2), and clamp (3).
- d. Install bearing (7), spacer (9), and lubrication fitting (8).
- e. Install hexagon capscrew (6), lockwasher (5), and flat washer (4).
- f. Remove tags and connect electrical leads.
- g. Remove tag and turn on electrical power at navigation light panel.

---

**3-49. Replace/Repair Searchlight Starter Assembly. (Figure 3-50)**

---

This task covers:

- |             |                |           |
|-------------|----------------|-----------|
| a. Removal  | b. Disassembly | c. Repair |
| d. Assembly | e. Replacement |           |
- 

**INITIAL SETUP:**Tools

Tool kit, general mechanic's,  
5180-00-699-5273  
Tool kit, electrician's,  
5180-00-391-1087

Equipment Condition

Shut down electrical power at  
navigation light panel. Tag "Out of  
Service - Do Not Operate."

Materials/Parts

Starter assembly P/N 4636X  
Power transformer P/N 9339X  
Capacitor P/N 2896  
Power transformer P/N 4407X  
Warning tags, Item 1, Appendix C

---

**REMOVAL****WARNING**

Extreme care must be observed while performing maintenance.  
High voltage radio frequency power is used in the lamp starting  
circuit.

**CAUTION**

Do not operate lamp starter circuit without lamp installed.

- a. Remove screws (2).
- b. Remove starter assembly plate (1) from searchlight drum assembly.

**DISASSEMBLY**

- a. Remove machine screw (3) and lockwasher (4).
- b. Remove plain hexagon nut (5) and lockwasher (6).

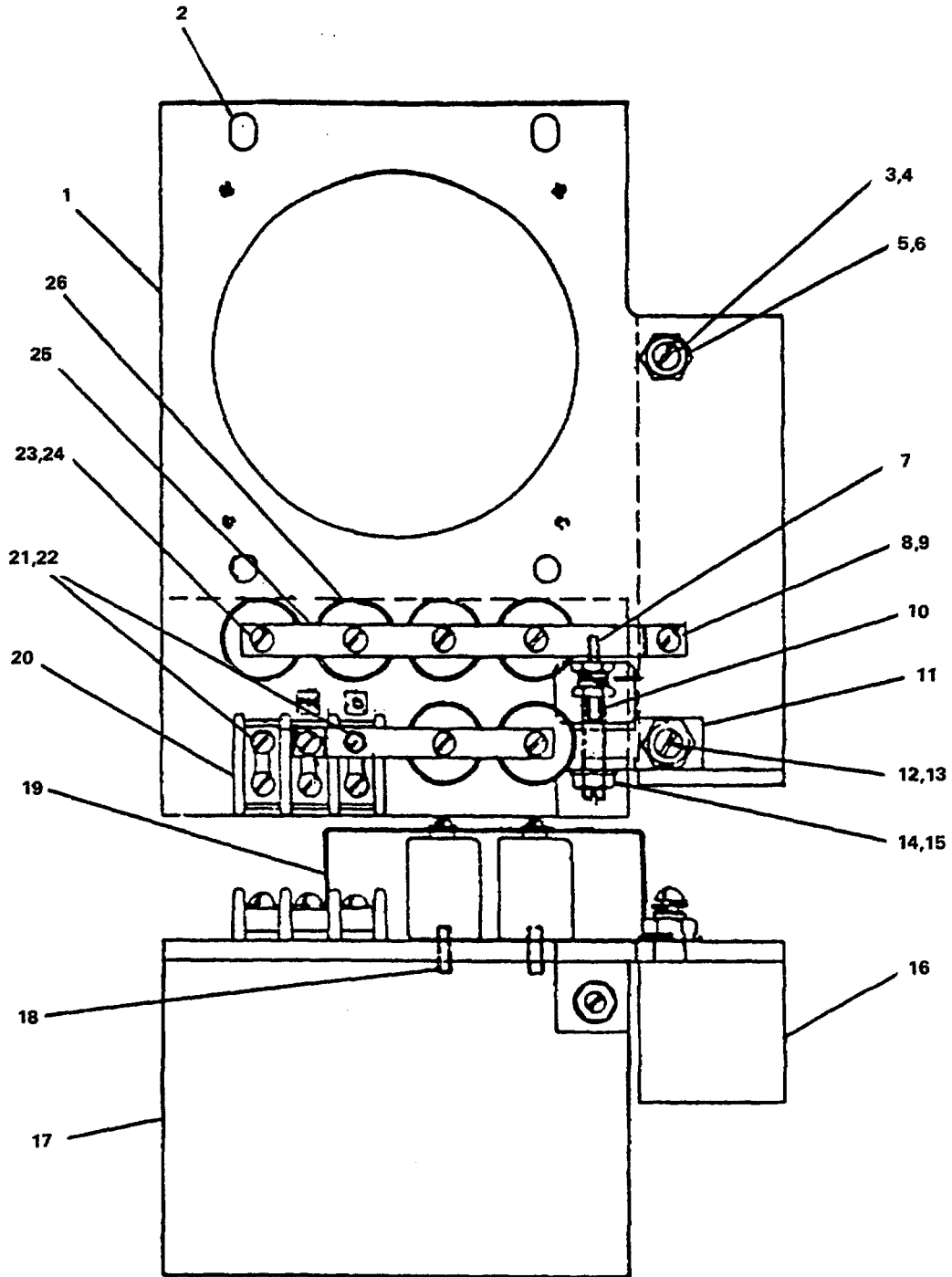

FIGURE 3-50. *Searchlight Starter Assembly.*

- c. Remove machine screw (12) and lockwasher (13).
- d. Remove power transformer (16).
- e. Remove machine screw (23) and lockwasher (24).
- f. Remove machine screw (8) and lockwasher (9).
- g. Remove brass connector (25).
- h. Remove sockethead setscrew (18).
- i. Remove capacitor (26).
- j. Remove machine screw (21) and lockwasher (22).
- k. Remove terminal block (20).
- l. Remove brass connector (19).
- m. Remove plain hexagon nut (14) and lockwasher (15).
- n. Remove contact screw (10).
- o. Remove electrical contact (7).
- p. Remove connector (11).
- q. Remove power transformer (17).

## REPAIR

Repair at this level of maintenance is by replacement of power transformer (16, 17), and capacitor (26).

## ASSEMBLY

- a. Install power transformer (17).
- b. Install connector (11).
- c. Install electrical contact (7).
- d. Install contact screw (10).
- e. Install lockwasher (15) and plain hexagon nut (14).
- f. Install brass connector (19).
- g. Install terminal block (20).
- h. Install lockwasher (22) and machine screw (21).

- i. Install capacitor (26).
- j. Install sockethead setscrew (18).
- k. Install brass connector (25).
- 1. Install lockwasher (9) and machine screw (8).
- m. Install lockwasher (24) and machine screw (23).
- n. Install power transformer (16).
- o. Install lockwasher (13) and machine screw (12).
- p. Install lockwasher (6) and plain hexagon nut (5).
- q. Install lockwasher (4) and machine screw (3).

#### **REPLACEMENT**

- a. Install starter assembly plate (1) into searchlight drum.
- b. Install screws (2).

---

**3-50. Replace/Repair Searchlight Power Supply. (Figure 3-51)**

---

**This task covers:**

- |             |                |           |
|-------------|----------------|-----------|
| a. Removal  | b. Disassembly | c. Repair |
| d. Assembly | e. Replacement |           |
- 

**INITIAL SETUP:**Tools

Tool kit, electrician's,  
5180-00-391-1087

Equipment Condition

Electrical power to searchlight  
power supply secured and  
tagged "Out of Service - Do Not  
Operate."

Materials/Parts

Circulating fan P/N 4434X  
Electromagnetic relay P/N 8433  
Time totalizing meter P/N 6094  
Ammeter P/N 9591  
Electromagnetic relay P/N 4722  
Paper - plastic dielectric  
metallized fixed capacitor  
P/N 4212X  
Cartridge fuse (30 AMP, 250V)  
P/N 4113A30  
Electrolytic fixed capacitor  
P/N 4404X  
Power transformer P/N 4395X  
Cartridge fuse P/N 4110A3  
Rectifier assembly P/N 4390X  
Electrolytic fixed capacitor  
P/N 4405  
Choke assembly P/N 4394X  
Resistor assembly P/N 9723X  
Warning tag, Item 1, Appendix C

---

**REMOVAL**

- a. Tag and disconnect electrical leads.
- b. Remove mounting bolts (34, Sheet 2).
- c. Remove enclosure assembly (31).

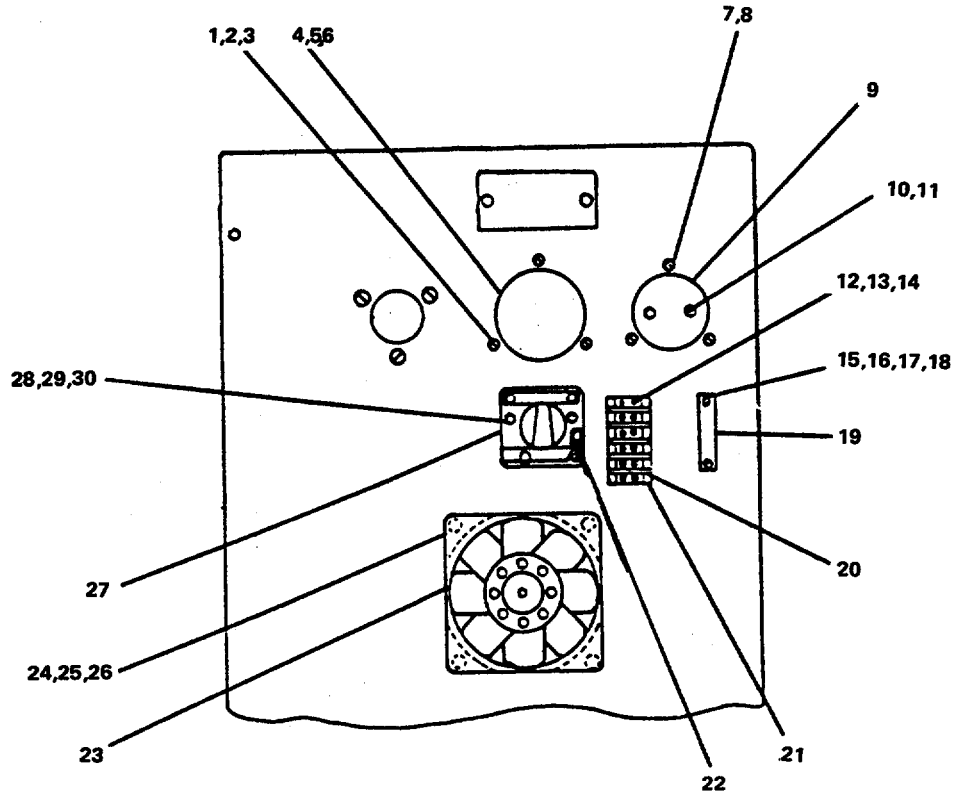

FIGURE 3-51. Searchlight Power Supply (Sheet 1 of 3).

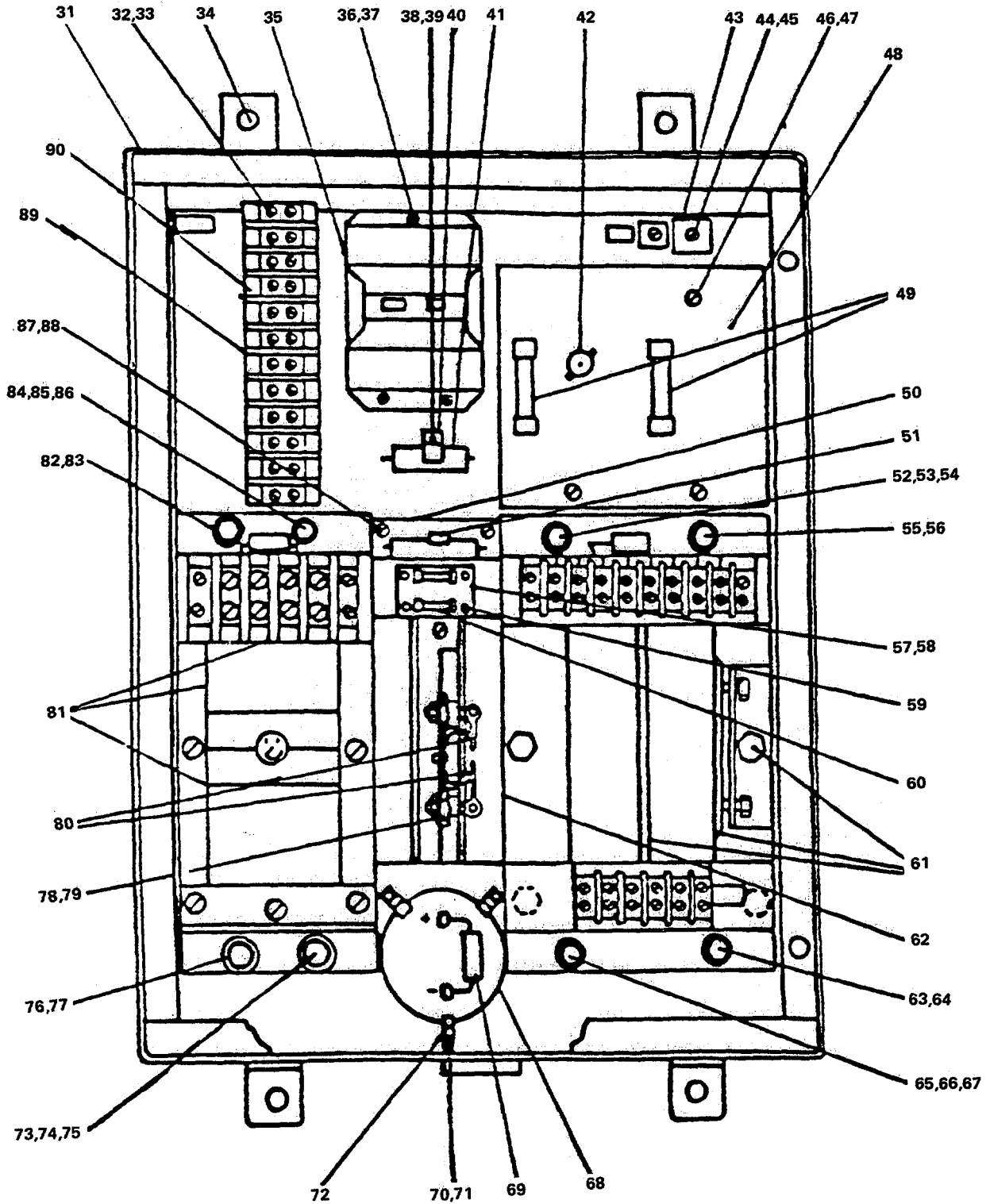

FIGURE 3-51. Searchlight Power Supply (Sheet 2 of 3).



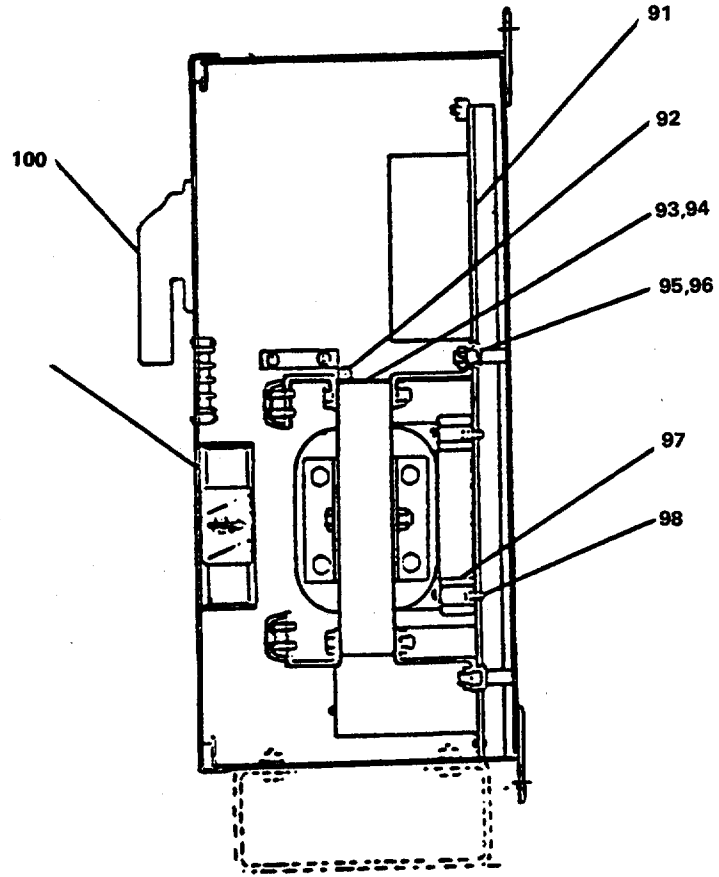

FIGURE 3-51. Searchlight Power Supply (Sheet 3 of 3).

**DISASSEMBLY**

- a. Remove plain hexagon nut (1, Sheet 1), lockwasher (2), and machine screw (3).
- b. Remove plain hexagon nut (5) and lockwasher (6).
- c. Tag and disconnect electrical leads. Remove time totalizing meter (4).
- d. Remove machine screw (7) and lockwasher (8).
- e. Remove plain hexagon nut (10) and lockwasher (11).
- f. Tag and disconnect electrical leads. Remove ammeter (9).
- g. Remove machine screw (12), lockwasher (13) and plain hexagon nut (14).
- h. Tag and disconnect electrical leads. Remove terminal board (20).
- i. Remove terminal board marker strip (21).
- j. Remove machine screw (18), flat washer (17), lockwasher (16) and plain hexagon nut (15).
- k. Remove electrical component tie-down strap (19).
- l. Remove plain hexagon nut (26), lockwasher (25) and machine screw.(24).
- m. Remove circulating fan (23).
- n. Remove plain hexagon nut (28), lockwasher (29) and machine screw (30).
- o. Tag and disconnect electrical leads. Remove electromagnetic relay (27) and resistor assembly (22).
- p. Remove machine screw (32, Sheet 2) and lockwasher (33).
- q. Tag and disconnect electrical leads. Remove terminal board (90) and identification plate (89).
- r. Remove machine screw (36) and lockwasher (37).
- s. Remove electromagnetic relay (32).
- t. Remove machine screw (38), lockwasher (39) and cartridge clamp (40).
- u. Remove fixed capacitor (41).
- v. Remove machine screw (44) and lockwasher (45).
- w. Remove ground lug terminal (43)
- x. Remove shaft (42).

- y. Remove machine screw (46) and flat washer (47).
- z. Remove fusible disconnect switch (48).
- aa. Remove cartridge fuse (49).
- ab. Remove electrolytic fixed capacitor (50).
- ac. Remove machine screw (84) and lockwasher (85).
- ad. Remove bracket (50).
- ae. Remove hexagon head capscrews (52, 65), lockwashers (53, 66), and flat washers (54, 67).
- af. Remove hexagon nuts (55, 63) and lockwashers (56, 64).
- ag. Remove power transformer (61).
- ah. Remove machine screw (59).
- ai. Remove cartridge fuse (60).
- aj. Remove fuse block (57) and insulator (58).
- ak. Remove deflector (62).
- al. Remove resistor (69).
- am. Remove machine screw (70), lockwasher (71), and clamp (72).
- an. Remove electrolytic fixed capacitor (68).
- ao. Remove hexagon nut (78) and lockwasher (79).
- ap. Remove rectifier assembly (80).
- aq. Remove hexagon head capscrews (73, 84), lockwashers (74, 85), and flat washers (75, 86).
- ar. Remove hexagon nut (76, 82) and lockwasher (77, 83).
- as. Remove choke assembly (81).
- at. Remove hexagon head capscrew (95, Sheet 3) and lockwasher (96).
- au. Remove steel plate (91).
- av. Remove machine screw (93) and lockwasher (94).
- aw. Remove clamp (92).
- ax. Remove setscrew (97) and insulator (98).

- ay. Remove screen (99).
- az. Remove handle (100).

## REPAIR

Repair at this level of maintenance is by replacement of circulating fan (23, Sheet 1), electromagnetic relay (27), time totalizing meter (4), ammeter (9), electro-magnetic relay (32, Sheet 2), metallized, paper-plastic dielectric fixed capacitor (41), cartridge fuse (49), electrolytic fixed capacitor (50), power transformer (61), cartridge fuse (60), rectifier assembly (80), choke assembly (81), and resistor assembly (69).

## ASSEMBLY

- a. Install handle (100, Sheet 3).
- b. Install screen (99).
- c. Install insulator (98) and setscrew (97).
- d. Install lockwasher (94) and machine screw (93).
- e. Install clamp (92).
- f. Install steel plate (91).
- g. Install lockwasher (96) and hexagon head capscrew (95).
- h. Install chock assembly (81, Sheet 2).
- i. Install lockwashers (77, 83) and hexagon nuts (76, 82).
- j. Install flat washers (75, 86), lockwashers (74, 85), and hexagon head capscrews (73, 84).
- k. Install rectifier assembly (80).
- 1. Install lockwasher (79) and hexagon nut (78).
- m. Install electrolytic fixed capacitor (68).
- n. Install clamp (72), lockwasher (71), and machine screw (70).
- o. Install resistor (69).
- p. Install deflector (62).
- q. Install insulator (58) and fuse block (57).
- r. Install cartridge fuse (60).

- s. Install machine screw (59).
- t. Install power transformer (61).
- u. Install lockwashers (56, 64) and hexagon nuts (55, 63).
- v. Install flat washers (54, 67), lockwashers (53, 66), and hexagon head capscrews (52, 65).
- w. Install bracket (50).
- x. Install lockwasher (85) and machine screw (84).
- y. Install electrolytic fixed capacitor (50).
- z. Install cartridge fuse (49).
- aa. Install fusible disconnect switch (48).
- ab. Install flat washer (47) and machine screw (46).
- ac. Install shaft (42).
- ad. Install ground lug terminal (43).
- ae. Install lockwasher (45) and machine screw (44).
- af. Install fixed capacitor (41).
- ag. Install cartridge clamp (40), lockwasher (39), and machine screw (38).
- ah. Install electromagnetic relay (32).
- ai. Install lockwasher (37) and machine screw (36).
- aj. Install identification plate (89) and terminal board (90). Remove tags and connect electrical leads.
- ak. Install lockwasher (33) and machine screw (32).
- al. Install resistor assembly (22, Sheet 1) and electromagnetic relay (27). Remove tags and connect electrical leads.
- am. Install machine screw (30), lockwasher (29) and plain hexagon nut (28).
- an. Install circulating fan (23).
- ao. Install machine screw (24), lockwasher (25), and plain hexagon nut (26).
- ap. Install electrical component tie-down strap (19).
- aq. Install plain hexagon nut (15), lockwasher (16), flat washer (17), and machine screw (18).

- ar. Install terminal board marker strip (21).
- as. Install terminal board (20). Remove tags and connect electrical leads.
- at. Install plain hexagon nut (14), lockwasher (13), and machine screw (12).
- au. Install ammeter. Remove tags and connect electrical leads.
- av. Install lockwasher (11) and plain hexagon nut (10).
- aw. Install lockwasher (8) and machine screw (7).
- ax. Install time totalizing meter (4). Remove tags and connect electrical leads.
- ay. Install lockwasher (6) and plain hexagon nut (5).
- az. Install machine screw (3), lockwasher (2), and plain hexagon nut (1).

#### **REPLACEMENT**

- a. Install enclosure assemble (31, Sheet 2).
- b. Install mounting bolts (34).
- c. Remove tags and connect electrical leads.
- d. Remove tag and turn on electrical power to searchlight power supply.

---

**3-51. Repair Searchlight Manual Lever Control. (Figure 3-52)**

---

This task covers:

**a. Disassembly**

**b. Repair**

**c. Assembly**

---

**INITIAL SETUP:**Tools

Tool kit, general mechanic's,  
5180-00-699-5273

Equipment Condition

Searchlight removed, para. 3-47 .

Materials/Parts

Preformed packing P/N 2285K  
Preformed packing P/N 2285TT

---

**DISASSEMBLY**

- a. Remove hexagon capscrew (6), lockwasher (5), and flat washer (4).
- b. Remove bearing (7), spacer (9), and lubrication fitting (8).
- c. Remove machine screw (1), lockwasher (2), and clamp (3).
- d. Remove headless straight pin (10).
- e. Remove pinion (24) and preformed packing (23).
- f. Remove spacer nut (11), sealing washer (12), and yoke assembly (16).
- g. Remove lubrication fitting (13).
- h. Remove preformed packing (21).
- i. Remove flanged bearing (14).
- j. Remove sliding stop (15) and retaining ring (16).
- k. Remove clamp assembly (19).
- l. Remove control rod (18) and control tube (17).
- m. Remove base (25).

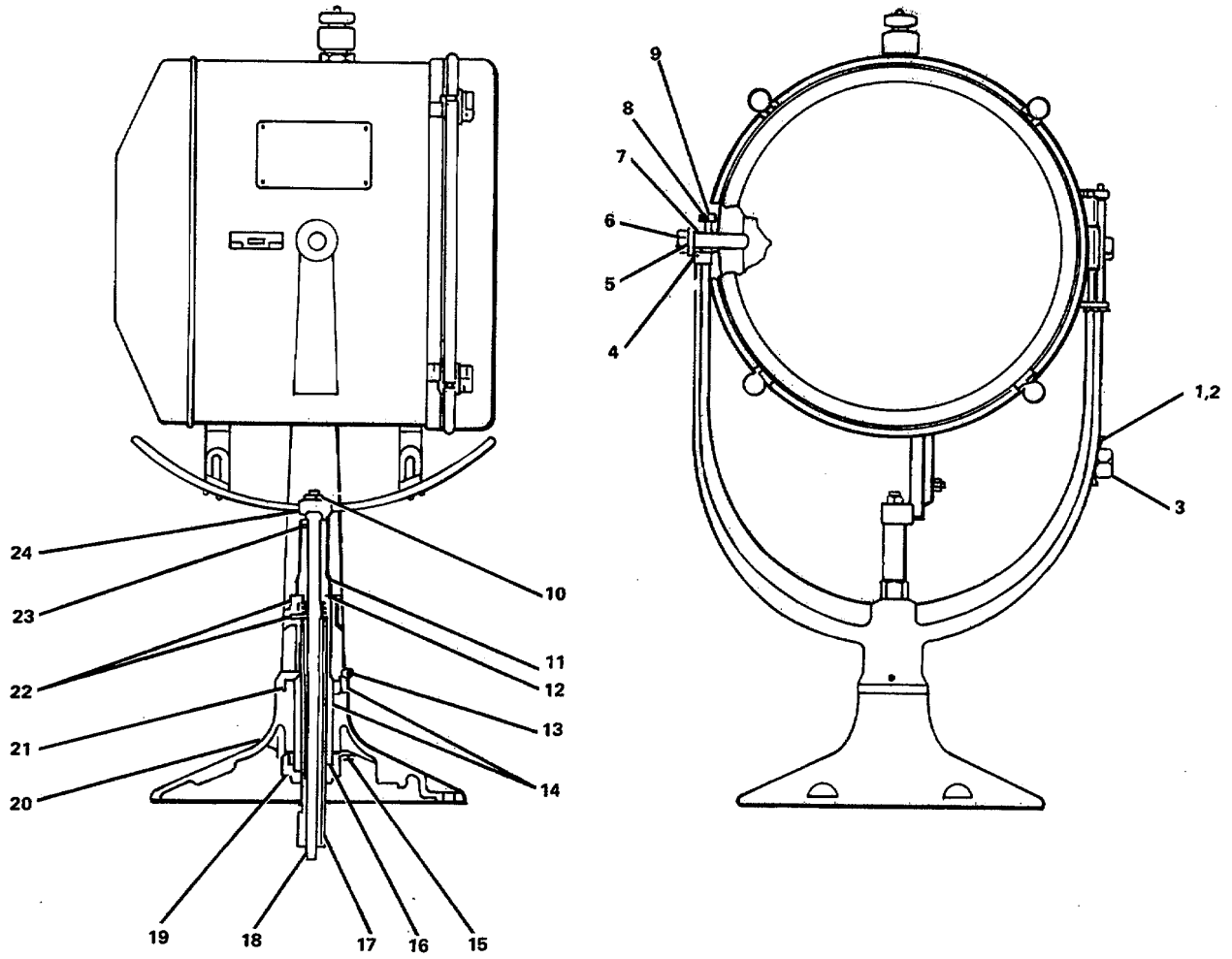

FIGURE 3-52. Searchlight Manual Control.



## REPAIR

Repair at this level of maintenance is by replacement of preformed packings (21, 23).

## ASSEMBLY

- a. Install base (25).
- b. Install control tube (17) and control rod (18).
- c. Install clamp assembly (19).
- d. Install retaining ring (16) and sliding stop (15).
- e. Install flanged bearing (14).
- f. Install preformed packing (21).
- g. Install lubrication fitting (13).
- h. Install yoke assembly (16), sealing washer (12) and spacer nut (11).
- i. Install preformed packing (23) and pinion (24).
- l. Install headless straight pin (10).
- k. Install clamp (3), lockwasher (2), and machine screw (1).
1. Install lubrication fitting (8), spacer (9), and bearing (7).
- m. Install flat washer (4), lockwasher (5), and hexagon capscrew (6).
- n. Refer to paragraph 3-47 to replace searchlight.

---

**3-52. Repair Searchlight Level Gear Assembly. (Figure 3-53)**

---

**This task covers:**

<b>a.</b>	<b>Disassembly</b>	<b>b. Repair</b>	<b>c. Assembly</b>
-----------	--------------------	------------------	--------------------

---

**INITIAL SETUP:**Tools

Tool kit, general mechanic's,  
5180-00-699-5273

Equipment Condition

Searchlight removed, para. 3-47 .

Materials/Parts

Level gear assembly P/N SL 3455XA

---

**DISASSEMBLY**

- a. Remove hexagon capscrew (5) and handle (2).
- b. Remove locknut (6) and lever shaft (22).
- c. Remove setscrew (8) and bearing (7).
- d. Remove machine screw (14) and lockwasher (15).
- e. Remove cover (16).
- f. Remove socket capscrew (13).
- g. Remove setscrew (18).
- h. Remove angle drive unit (21).
- i. Remove spring (20).
- j. Remove bearing (19) and spacer (17).
- k. Remove square key (12).
- l. Remove miter gear (9).
- m. Remove bearing (11).
- n. Remove straight shaft (20).

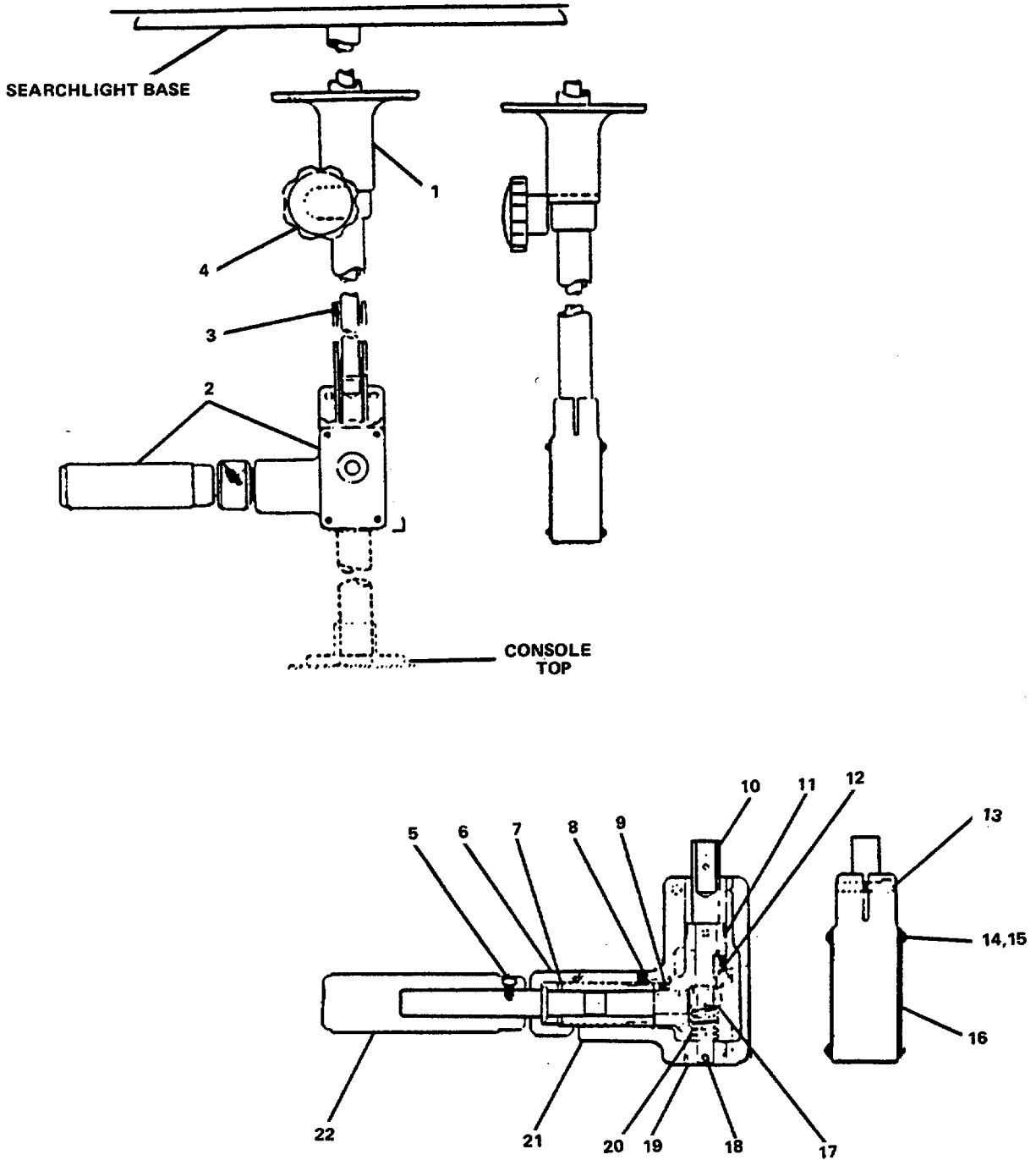

FIGURE 3-53. Searchlight Leveling Gear Assembly.

- o. Remove flat washer (3).
- p. Remove machine screw (4).
- q. Remove ceiling lock (1).

## REPAIR

Repair at this level of maintenance is by replacement of worn or defective parts.

## ASSEMBLY

- a. Install ceiling lock (1).
- b. Install machine screw (4).
- c. Install flat washer (3).
- d. Install straight shaft (20).
- e. Install bearing (11).
- f. Install miter gear (9).
- g. Install square key (12).
- h. Install spacer (17) and bearing (19).
- i. Install spring (20).
- j. Install angle drive unit (21).
- k. Install setscrew (18).
- l. Install socket capscrew (13).
- m. Install cover (16).
- n. Install lockwasher (15) and machine screw (14).
- o. Install bearing (7) and setscrew (8).
- p. Install lever shaft (22) and locknut (6).
- q. Install handle (2) and hexagon capscrew (5).
- r. Refer to paragraph 3-47 for searchlight replacement.

---

**3-53. Replace/Repair Searchlight Control Station. (Figure 3-54)**

---

**This task covers:**

- |             |                |           |
|-------------|----------------|-----------|
| a. Removal  | b. Disassembly | c. Repair |
| d. Assembly | e. Replacement |           |
- 

**INITIAL SETUP:**Tools

Tool kit, electrician's,  
5180-00-391-1087

Materials/Parts

Toggle switch P/N 8621  
Rotary switch P/N 9855  
Warning tag, Item 1, Appendix C

Equipment Condition

Electrical power secured to  
searchlight control station  
and tagged "Out of Service - Do Not  
Operate."

---

**REMOVAL**

- Tag and disconnect electrical leads.
- Remove screws (4) and switch plate (5).

**DISASSEMBLY**

- Remove locking ring (7) and lockwasher (8).
- Remove toggle switch (9).
- Remove rotary switch (6).
- Remove locking ring (1) and lockwasher (2).
- Remove toggle switch (3).

**REPAIR**

Repair at this level of maintenance is by replacement of toggle switch (3, 9) and rotary switch (6).

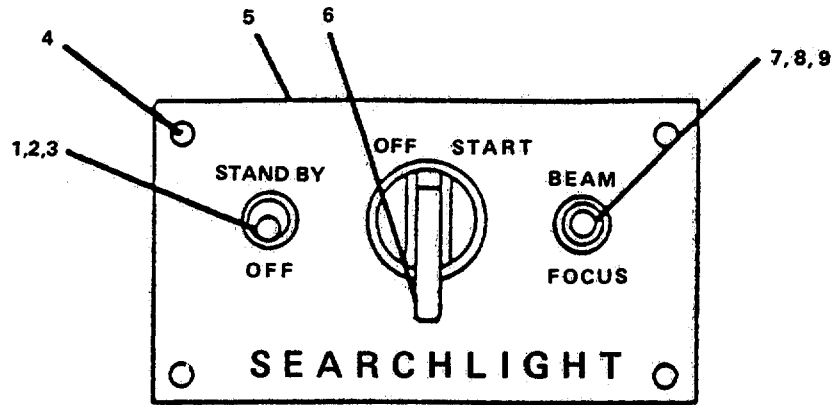

FIGURE 3-54. Searchlight Control Station.

**ASSEMBLY**

- a. Install toggle switch (3).
- b. Install lockwasher (2) and locking ring (1).
- c. Install rotary switch (6).
- d. Install toggle switch (9).
- e. Install lockwasher (8) and locking ring (7).

**REPLACEMENT**

- a. Install switch plate (5) and screws (4).
- b. Remove tag and connect electrical leads.
- c. Remove tag and turn on electrical power to searchlight control station.

<b>MAINTENANCE OF MACHINERY SHOP EQUIPMENT</b>
--

---

**3-54. Repair Arc Welding Machine.****This task covers:****a. Disassembly****b. Repair****c. Assembly****INITIAL SETUP**Tools

Tool kit, general mechanic's,  
5180-00-699-5273

Tool kit, electrician's,  
5180-00-391-1087

Equipment Condition

Welding machine removed, para. 2-51 .

Materials/Parts

Capacitor P/N 1373-0462

Fixed capacitors P/N 1373-0476,  
P/N 1373-2461

Gas connector P/N 0803-0281

Gas solenoid valve P/N 1373-4673

Gasket P/N 1373-0783

Transformer assembly  
P/N 1373-4648

Water connector P/N 0803-0280

Water solenoid valve P/N 1373-4674

**DISASSEMBLY**

- a. Remove top panel (1, Figure 3-55) bushing (2), dust and moisture seal protective cap (3) and gasket (4).
- b. Remove access door (7) and panel (8).
- c. Remove cover (5) and panel (6).
- d. Remove panel (10).
- e. Remove fastener cover (19).
- f. Remove spring latch (22).
- g. Remove terminal cover assembly (23).
- h. Remove insulated terminal (24) and terminal bus bar (25).

- i. Remove gas solenoid valve (1, Figure 3-56).
- j. Remove water solenoid valve (2).
- k. Remove gas connector (27, Figure 3-55).
- l. Remove water connector (26).
- m. Remove handle (20) and mode switch (21).
- n. Remove fan housing (10) and fan blade (11).
- o. Remove alternating current motor (12).

**WARNING**

Transformer assembly may contain electrical charges and must be grounded with a shorting bar to prevent electrical shock.

- p. Remove transformer assembly (13).
- q. Remove terminal board (28), voltage link (29), and terminal studs (30, 31)

**WARNING**

Capacitors may contain electrical charges and must be grounded with a shorting bar to prevent electrical shock.

- r. Remove capacitor (32) and capacitor bracket (33).
- s. Remove panel (14).
- t. Remove fixed capacitors (15, 16).
- u. Remove shunt assembly (17).
- v. Remove bus bar (18).

**REPAIR**

Repair at this level of maintenance is by replacement of: gasket (4, Figure 3-55), gas connector (27), water connector (26), transformer assembly (13), capacitor (32), fixed capacitors (15, 16), gas solenoid valve (1, Figure 3-56), water solenoid (2).



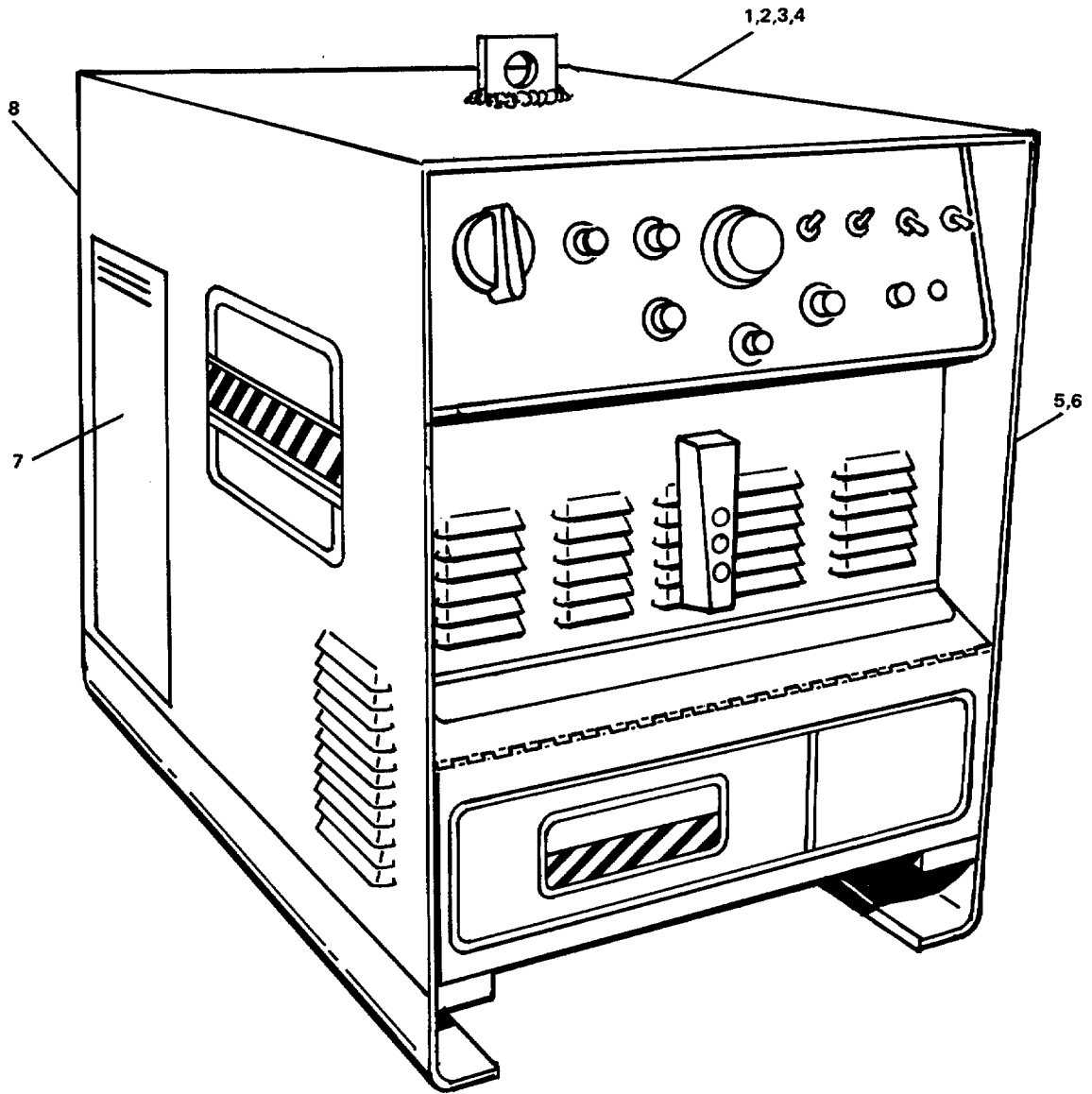

FIGURE 3-55. Repair Arc Welding Machine (Sheet 1 of 2).

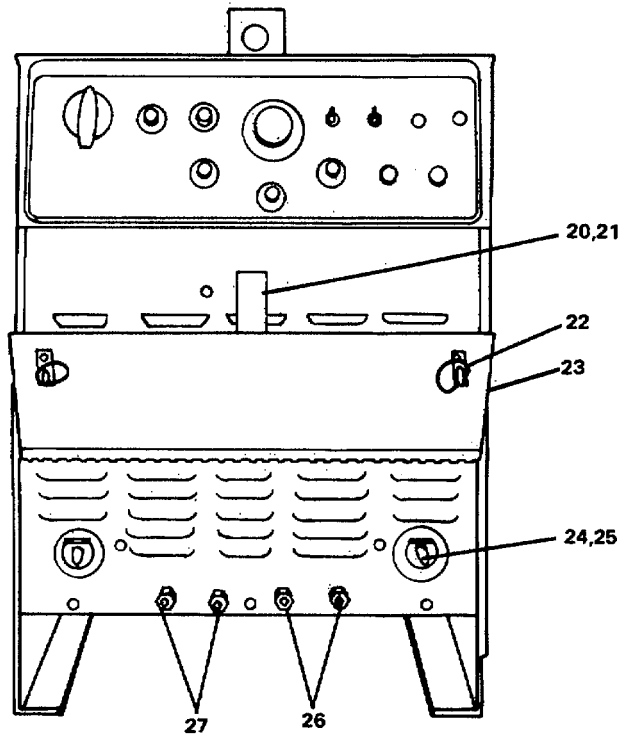
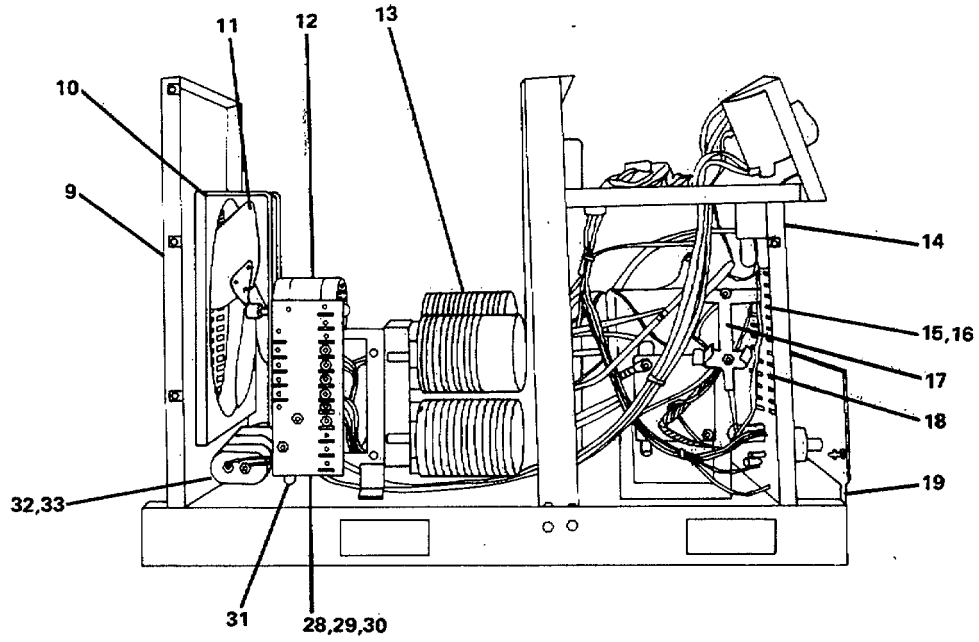

FIGURE 3-55. *Repair Arc Welding Machine (Sheet 2 of 2).*

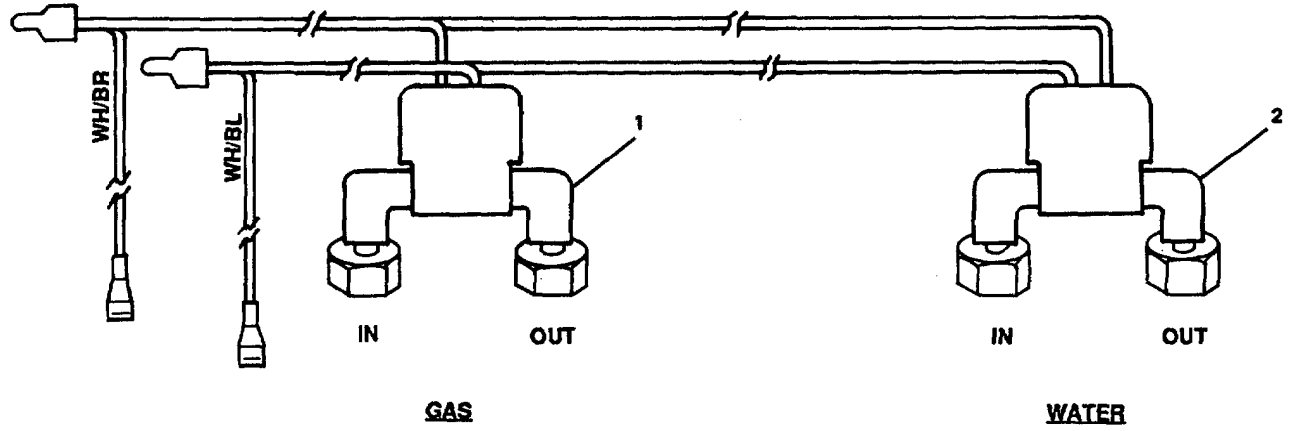

FIGURE 3-56. Gas and Water Solenoid Valves.

**ASSEMBLY**

- a. Install bus bar (18).
- b. Install shunt assembly (17).
- c. Install fixed capacitors (15, 16).
- d. Install panel (14).
- e. Install capacitor bracket (33) and capacitor (32).
- f. Install terminal studs (30, 31) voltage link (29), and terminal board (28).
- g. Install transformer assembly (13).
- h. Install alternating current motor (12).
- i. Install fan blade (11) and fan housing (10).
- j. Install mode switch (21) and handle (20).
- k. Install water connector (26).
- l. Install gas connector (27).
- m. Install water solenoid valve (2, Figure 3-56).
- n. Install gas solenoid valve (1).
- o. Install terminal bus bar (25, Figure 3-55) and insulated terminal (24).
- p. Install terminal cover assembly (23).
- q. Install spring latch (22).
- r. Install fastener cover (19).
- s. Install panel (10).
- t. Install panel (6) and cover (5).
- u. Install panel (8) and access door (7).
- v. Install gasket (4), dust and moisture seal protective cap (3), bushing (2), and top panel (1).

---

**3-55. Replace/Repair Electronic Component Assembly. (Figure 3-57)**

---

**This task covers:**

- |             |                |           |
|-------------|----------------|-----------|
| a. Removal  | b. Disassembly | c. Repair |
| d. Assembly | e. Replacement |           |
- 

**INITIAL SETUP**Tools

Tool kit, electrician's,  
5180-00-391-1087

Equipment Condition

Welding machine removed, para. 2-51 and  
disassembled para. 3-54 .

Materials/Parts

Duel S.C.R. assembly  
P/N 1373-4016  
Capacitor assembly  
P/N 1373-4084  
175 watt, 50 Ohm electrical  
resistor P/N 1373-2087  
175 watt, 25 Ohm electrical  
resistor P/N 1373-4113

---

**REMOVAL**

- Remove hexagon nut (11), washer (10), and spacer (12).
- Remove electronic component assembly.
- Remove spacer (9).

**DISASSEMBLY**

- Remove duel S.C.R. assembly (2).
- Remove hexagon nut (3) and snubber board assembly (4).
- Remove rectifier bridge (5).
- Remove diode assembly (8).
- Remove capacitor assembly (6).
- Remove heat sink (1).
- Remove jumper tube (7).

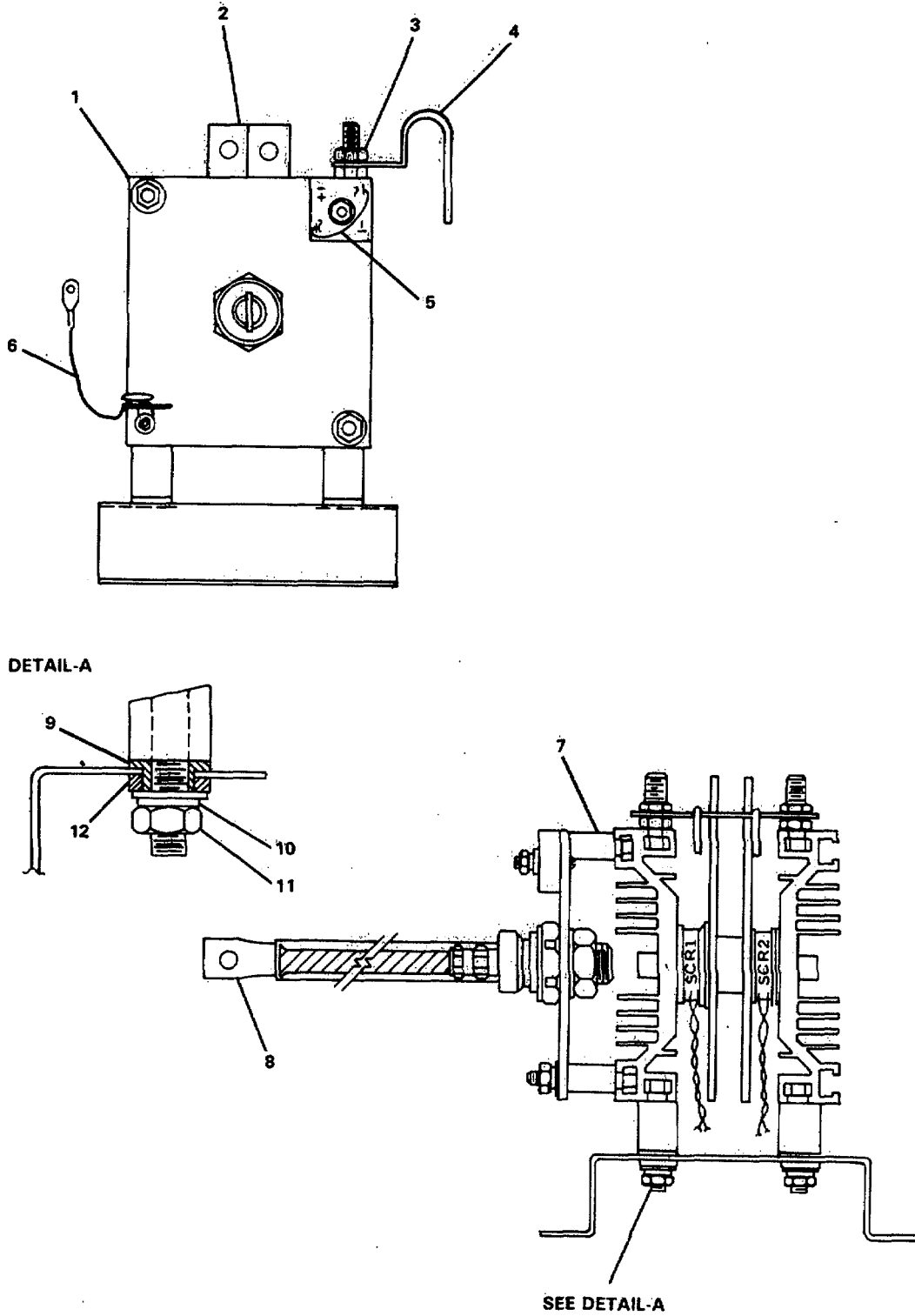

FIGURE 3-57. *Replace/Repair Electronic Component Module (Sheet 1 of 2)*

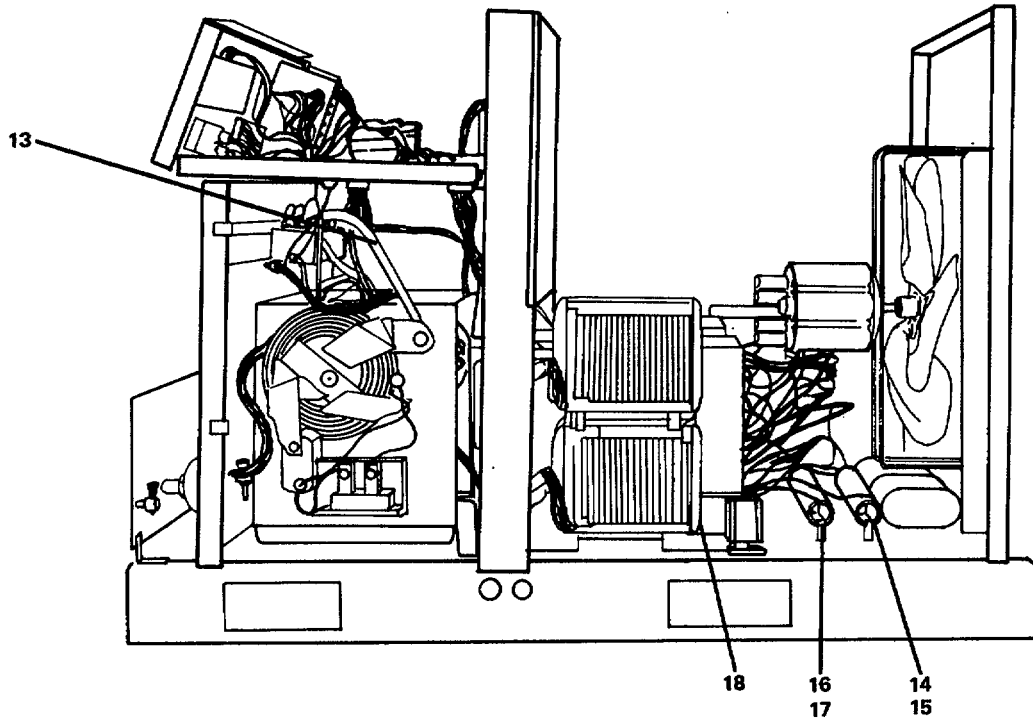

FIGURE 3-57. Replace/Repair Electronic Component Module (Sheet 2 of 2).

- h. Remove 175 watt, 25 Ohm electrical resistor (14) and resistor bracket (15).
- i. Remove 175 watt, 50 Ohm electrical resistor (16) and resistor bracket (17).
- j. Remove chock assembly (18).
- k. Remove bus bar (13).

### **REPAIR**

Repair at this level of maintenance is by replacement of: dual S.C.R. assembly (2), capacitor assembly (6), electrical resistors (14, 16).

### **ASSEMBLY**

- a. Install bus bar (13).
- b. Install chock assembly (18).
- c. Install resistor bracket (17) and 175 watt, 50 Ohm electrical resistor (16).
- d. Install resistor bracket (15) and 175 watt, 25 Ohm electrical resistor (14).
- e. Install jumper tube (7).
- f. Install heat sink (1).
- g. Install capacitor assembly (6).
- h. Install diode assembly (8).
- i. Install rectifier bridge (5).
- j. Install snubber board assembly (4) and hexagon nut (3).
- k. Install dual S.C.R. assembly (2).

### **REPLACEMENT**

- a. Install spacer (9)
- b. Install electronic component.
- c. Install spacer (12), washer (10) and hexagon nut (11).



---

**3-56. Replace/Repair High Frequency Assembly. (Figure 3-58)**

---

This task covers:

- |             |                |           |
|-------------|----------------|-----------|
| a. Removal  | b. Disassembly | c. Repair |
| d. Assembly | e. Replacement |           |
- 

**INITIAL SETUP:**Tools

Tool kit, electrician's,  
5180-00-391-1087

Equipment Condition

Welding machine removed, para. 2-51 and  
disassembled para. 3-54 .

Materials/Parts

High frequency assembly  
P/N 1373-4665  
Warning tags, Item 1, Appendix C

**REMOVAL**

- a. Tag and disconnect electrical leads.
- b. Remove hexagon bolt (4).
- c. Remove high frequency assembly (1).

**DISASSEMBLY**

- a. Remove tesla coil (7).
- b. Remove electrical resistor (2).
- c. Remove capacitor (6).
- d. Remove spark gap assembly (5).
- e. Remove transformer (3).

**REPAIR**

Repair at this level of maintenance is by replacement of: high frequency assembly (1) or defective components.

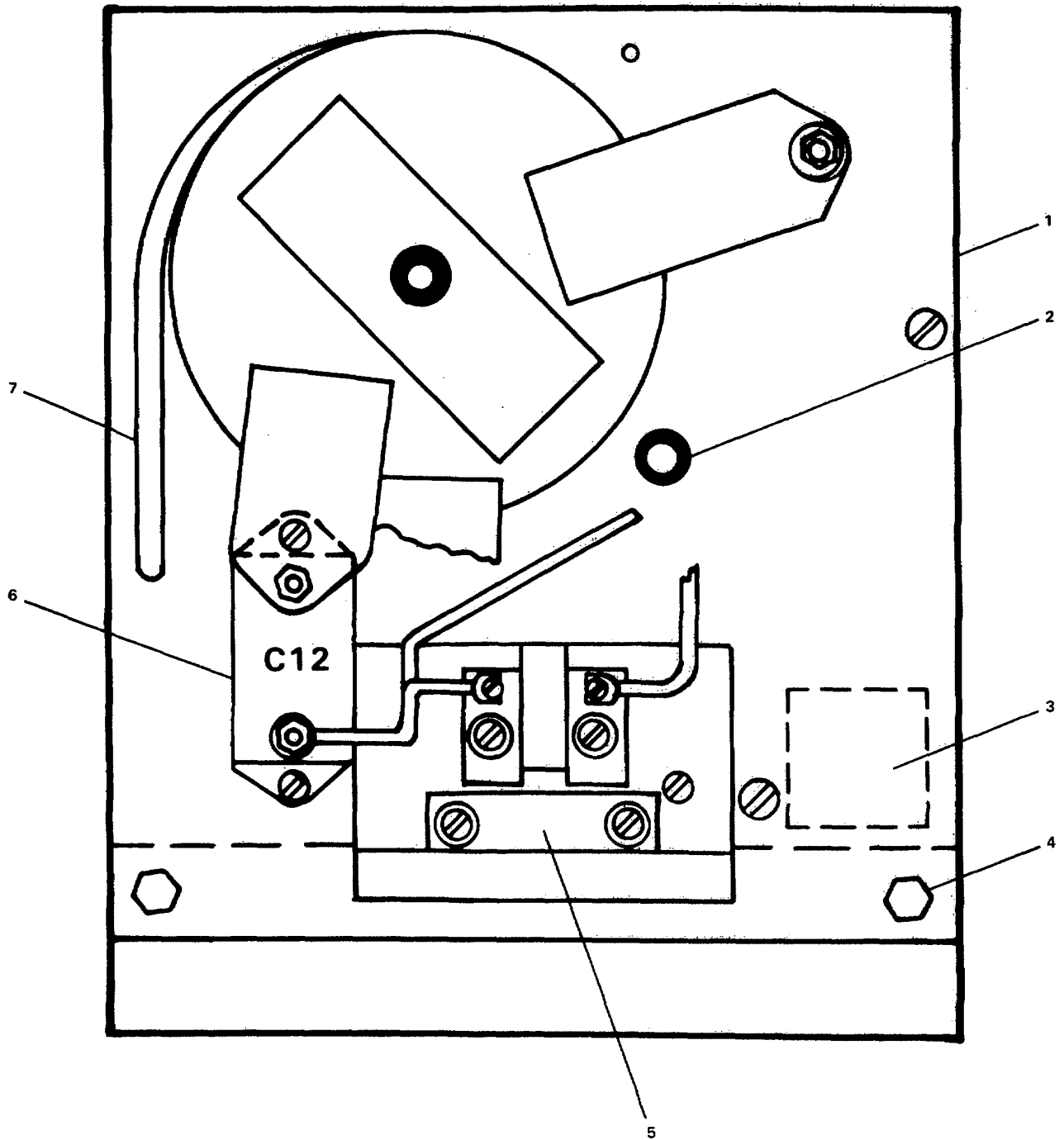

FIGURE 3-58 *Replace/Repair High Frequency Assembly.*

**ASSEMBLY**

- a. Install transformer (3).
- b. Install spark gap assembly (5).
- c. Install capacitor (6).
- d. Install electrical resistor (2).
- e. Install tesla coil (7).

**REPLACEMENT**

- a. Install high frequency assembly (1).
- b. Install hexagon bolt (4).
- c. Remove tags and connect electrical leads.

**3-57. Replace/Repair Electronic Module Assembly. (Figure 3-59)**

**This task covers:**

- |             |                |           |
|-------------|----------------|-----------|
| a. Removal  | b. Disassembly | c. Repair |
| d. Assembly | e. Replacement |           |

**INITIAL SETUP:**

Tools

Tool kit, electrician's,  
5180-00-391-1087

Equipment Condition

Welding machine removed, para. 2-51 and  
disassembled para. 3-54 .

Materials/Parts

Electronic module assembly  
P/N 1373-5145  
Rotary switch P/N 1373-4633  
Circuit breaker P/N 1373-0756  
Preflow timer assembly  
P/N 1388-0126  
Warning tags, Item 1, Appendix C

**REMOVAL**

- a. Tag and disconnect electrical leads.
- b. Remove hexagon bolt (4).
- c. Remove high frequency assembly (1).

**DISASSEMBLY**

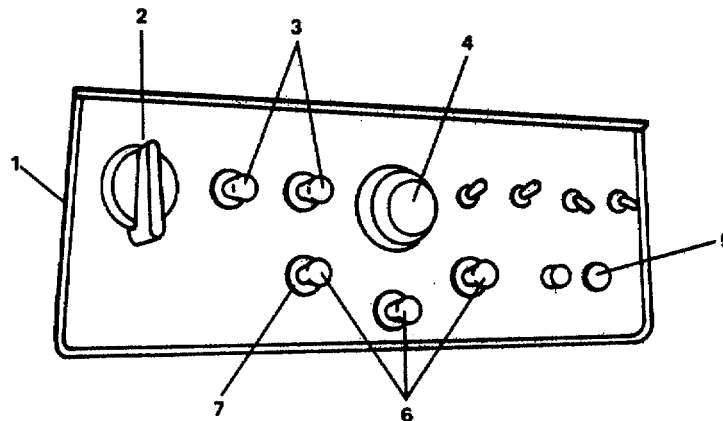

FIGURE 3-59. Replace Repair Electronic Module Assembly (Sheet 1 of 2).

- a. Remove rotary switch (2).
- b. Remove knobs (3, 6).
- c. Remove potentiometer (7).
- d. Remove knob (4).
- e. Remove circuit breaker (5).
- f. Remove switchboard assembly (16).
- g. Remove start current module assembly (17).
- h. Remove post flow module assembly (18).
- i. Remove preflow timer assembly (19).
- j. Remove ribbon cable assembly (15).
- k. Remove remote control assembly (21).
- l. Remove capacitor (9) and capacitor bracket (8).
- m. Remove capacitor (10) and capacitor bracket (11).
- n. Remove resistor (12).
- o. Remove resistor (22) and resistor bracket (23).
- p. Remove fixed capacitor (20).
- q. Remove duplex receptacle (14).
- r. Remove transformer (13).

## REPAIR

Repair at this level of maintenance is by replacement of: rotary switch (2), circuit breaker (5), preflow timer assembly (19).

## ASSEMBLY

- a. Install transformer (13).
- b. Install duplex receptacle (14).
- c. Install fixed capacitor (20).
- d. Install resistor bracket (23) and resistor (22).
- e. Install resistor (12).

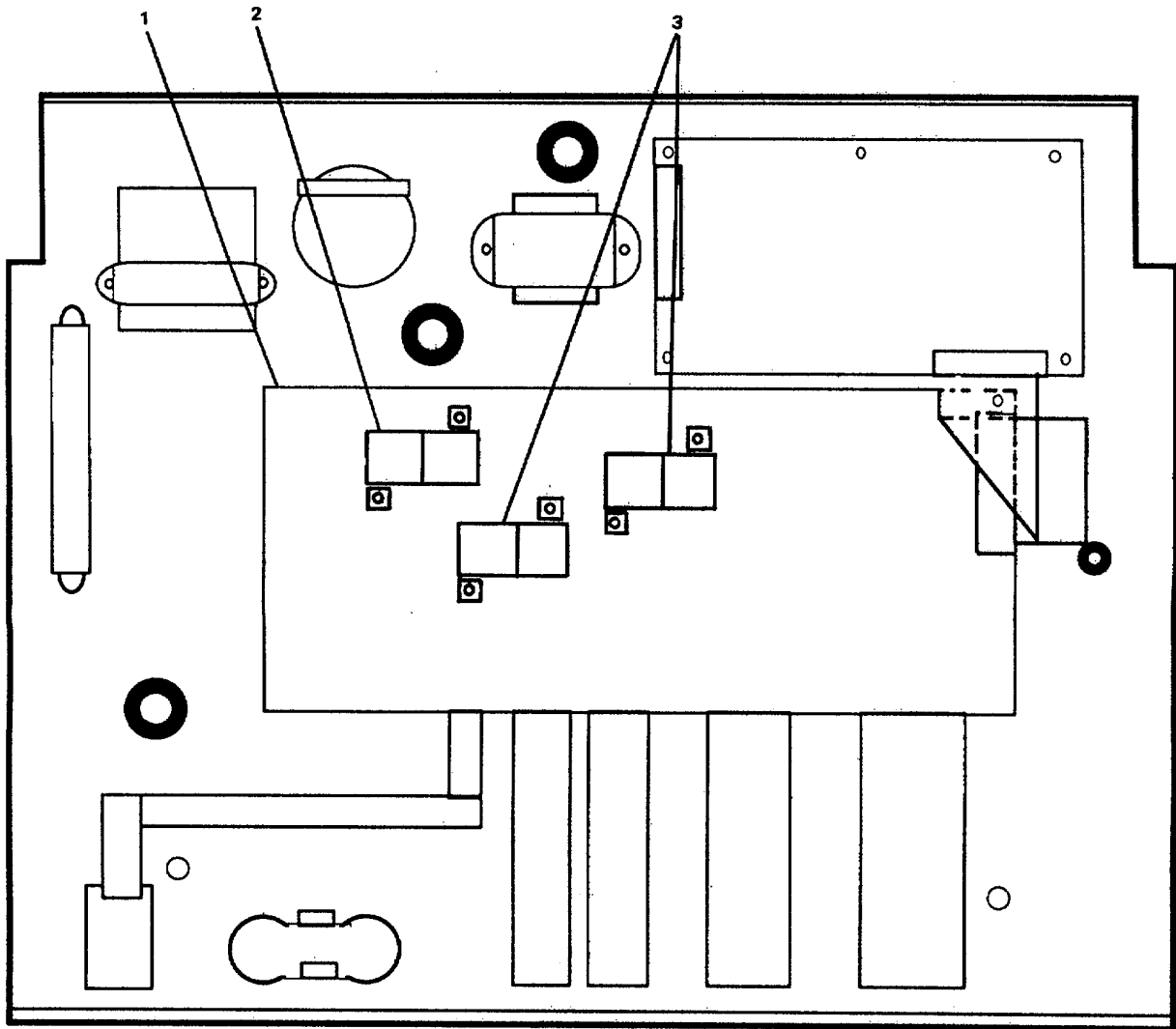

FIGURE 3-59. *Replace/Repair Electronic Assembly (Sheet 2 of 2).*

- f. Install capacitor bracket (11) and capacitor (10).
- g. Install capacitor bracket (8) and capacitor (9).
- h. Install remote control assembly (21).
- i. Install ribbon cable assembly (15).
- j. Install preflow timer assembly (19).
- k. Install post flow module assembly (10).
- l. Install start current module assembly (9).
- m. Install switchboard assembly (18).
- n. Install circuit breaker (5).
- o. Install knob (4).
- p. Install potentiometer (7).
- q. Install knobs (3, 6).
- r. Install rotary switch (2).

#### **REPLACEMENT**

- a. Install electronic module assembly (1).
- b. Remove tags and connect electrical leads.

---

**3-58. Replace/Repair Interface Printed Circuit Board. (Figure 3-60)**

---

**This task covers:**

- |             |                |           |
|-------------|----------------|-----------|
| a. Removal  | b. Disassembly | c. Repair |
| d. Assembly | e. Replacement |           |
- 

**INITIAL SETUP:**Tools

Tool kit, electrician's,  
5180-00-391-1087

Equipment Condition

Welding machine removed, para. 2-51 and  
disassembled para. 3-54 .  
Electronic module assembly removed, para. 3-57 .

Materials/Parts

Interface printed circuit board  
P/N 1373-4767  
Electromagnetic relay  
P/N 1373-4627  
Electromagnetic relay (2)  
P/N 1373-4638  
Warning tags, Item 1, Appendix C

**REMOVAL**

- a. Tag and disconnect electrical leads.
- b. Remove interface printed circuit board (1).

**DISASSEMBLY**

- a. Remove electromagnetic relay (2).
- b. Remove electromagnetic relays (3).

**REPAIR**

Repair at this level of maintenance is by replacement of: interface printed circuit board (1),  
electromagnetic relays (2, 3).

**ASSEMBLY**

- a. Install electromagnetic relays (3).
- b. Install electromagnetic relay (2).



**REPLACEMENT**

- a. Install interface printed circuit board (1).
- b. Remove tags and connect electrical leads.

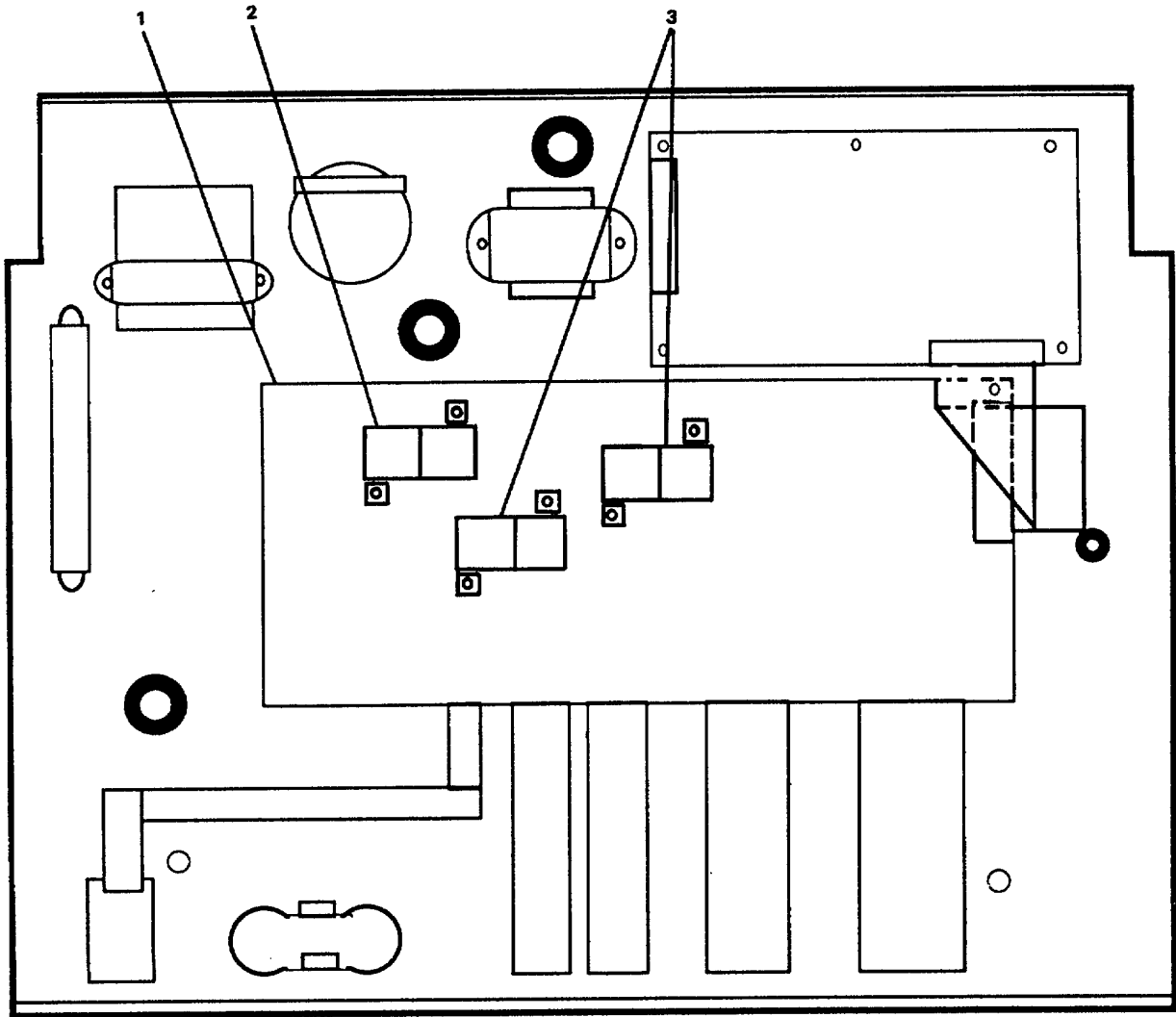

FIGURE 3-60. *Replace/Repair Interface Printed Circuit Board.*

---

**3-59. Replace/Repair Control Printed Circuit Board. (Figure 3-61)**

---

**This task covers:****a. Removal****b. Repair****c. Replacement**

---

**INITIAL SETUP:**Tools

Tool kit, electrician's,  
5180-00-391-1087

Equipment Condition

Welding machine removed, para. 2-51 and  
disassembled para. 3-54 .  
Electronic module assembly removed, para. 3-57 .

Materials/Parts

Control printed circuit  
board P/N 1373-4988  
Warning tags, Item 1, Appendix C

**REMOVAL**

- a. Tag and disconnect electrical, leads.
- b. Remove control printed circuit board (1).

**REPAIR**

Repair at this level of maintenance is by replacement of: control printed circuit board (1).

**REPLACEMENT**

- a. Install control printed circuit board (1).
- b. Remove tags and connect electrical leads.

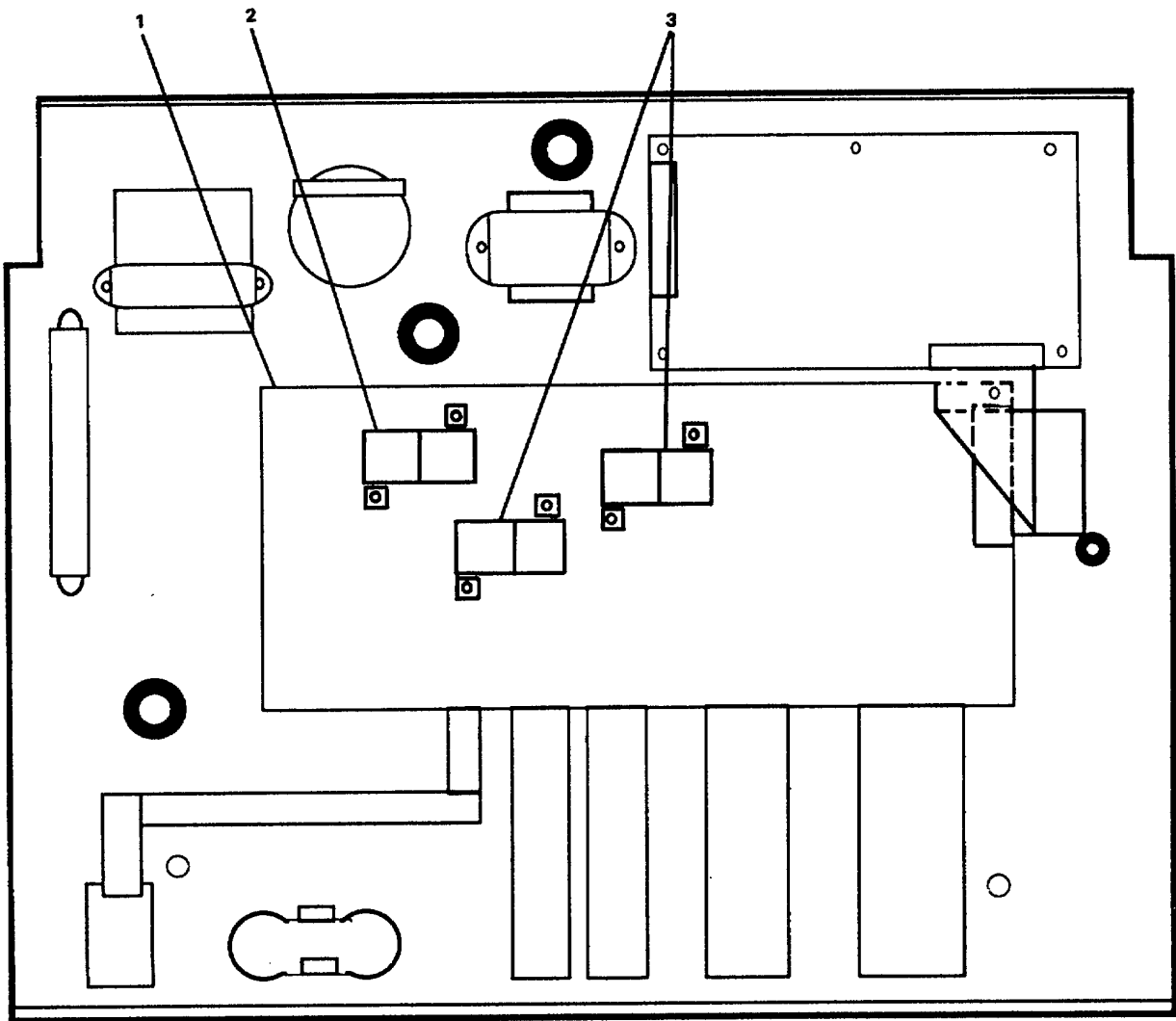

FIGURE 3-61. Replace/Repair Control Printed Circuit Board.

<b>MAINTENANCE OF COMMISARY EQUIPMENT</b>
---

**3-60. Replace/Repair Interface Printed Circuit Board. (Figure 3-60)****This task covers:****a. Disassembly****b. Repair****c. Assembly.****INITIAL SETUP:**Tools

Tool kit, general mechanic's  
5180-00-699-5273  
Tool kit, electrician's,  
5180-00-391-1087

Equipment Condition

Electric range assembly and solid  
surface units removed, para. 2-54 .

Materials/Parts

Twin panel plate P/N 20B1A-30  
Temperature switch P/N 4111A8733  
Thermostatic switch P/N 18AIS-74  
Indicator light P/N F706A8727  
Warning tags, Item 1, Appendix C

**DISASSEMBLY**

- a. Tag and disconnect electrical leads from temperature switch (3) for corresponding hot plate (1) mounted in twin panel plate (2).
- b. Remove temperature switch (3).
- c. Remove fuse compartment door (4).
- d. Remove switch panel (9).
- e. Tag and disconnect electrical lead from temperature switch (6).
- f. Remove knob switch (8) and knob adaptor (7).
- g. Remove temperature switch.
- h. Tag and disconnect electrical leads from thermostatic switch (5).
- i. Remove switch knob (11).

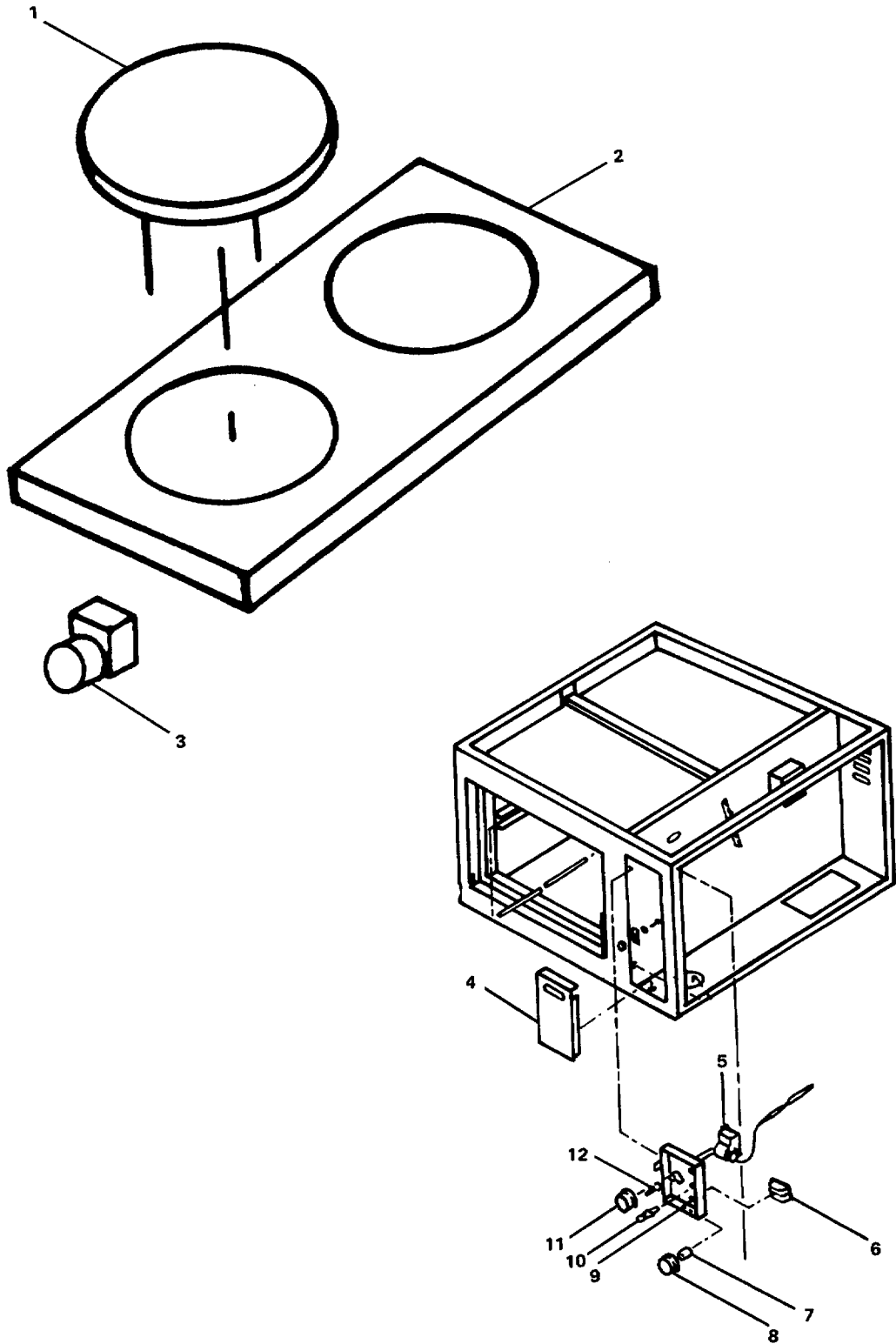

FIGURE 3-62. *Repair Electric Range Assembly.*

- j. Remove machine screws (12) and remove thermostatic switch (5).
- k. Tag and disconnect electrical leads from indicator light (10).
- l. Compress retaining ears and remove indicator light.

## REPAIR

Repair at this level of maintenance is by replacement of twin panel plate (2, Sheet 1), temperature switches (3 and 6) thermostatic switch (5), indicator light (10).

## ASSEMBLY

- a. Compress retaining ears and install indicator light (10).
- b. Remove tags and connect electrical leads.
- c. Install thermostatic switch (5) with machine screws (12).
- d. Install switch knob (11).
- e. Remove tags and connect electrical leads.
- f. Install temperature switch (6).
- g. Install knob adapter (7) and switch knob (8).
- h. Remove tags and connect electrical leads.
- i. Install switch panel (9).
- j. Install fuse compartment door (4).
- k. Install temperature switch (3) for corresponding hot plate (1) mounted in twin panel plate (2).
- 1. Remove tags and connect electrical leads.
- m. Replace solid surface units and the electric range assembly, paragraph 2-54 .

**3-61. Repair Self-Heating Griddle. (Figure 3-63)****This task covers:****a. Disassembly****b. Repair****c. Assembly.****INITIAL SETUP:**Tools

Tool kit, electrician's,  
5180-00-699-5273

Equipment Condition

Self-heating griddle removed,  
para. 2-55 .

Materials/Parts

Knob P/N A710E8751  
Thermostatic control P/N 2262A8723  
Indicator light P/N 1433B8701  
Electrical nonimmersion-type heating  
element P/N 7236B8714  
Warning tags, Item 1, Appendix C

**DISASSEMBLY**

- a. Remove machine screws (17) securing case bottom (1) to griddle.
- b. Remove case bottom.
- c. Pull off knob (14) and remove machine screws (15), hexagon nuts (2) and lockwashers (3).
- d. Remove control mounting cups (13).
- e. Move thermostatic control (4) to side until probe is disconnected.
- f. Push out indicator light (16) through opening.
- g. Tag and disconnect electrical leads to indicator light (16).
- h. Remove indicator light.
- i. Remove hexagon nuts (10) and washers (9) securing baffle (7).
- j. Remove baffle.
- k. Remove two hexagon nuts (10) and cup washers (12).
- l. Remove thermostatic control (4) with attached probe.
- m. Remove hexagon nuts (10) and flat washers (8) from eyelet (11).

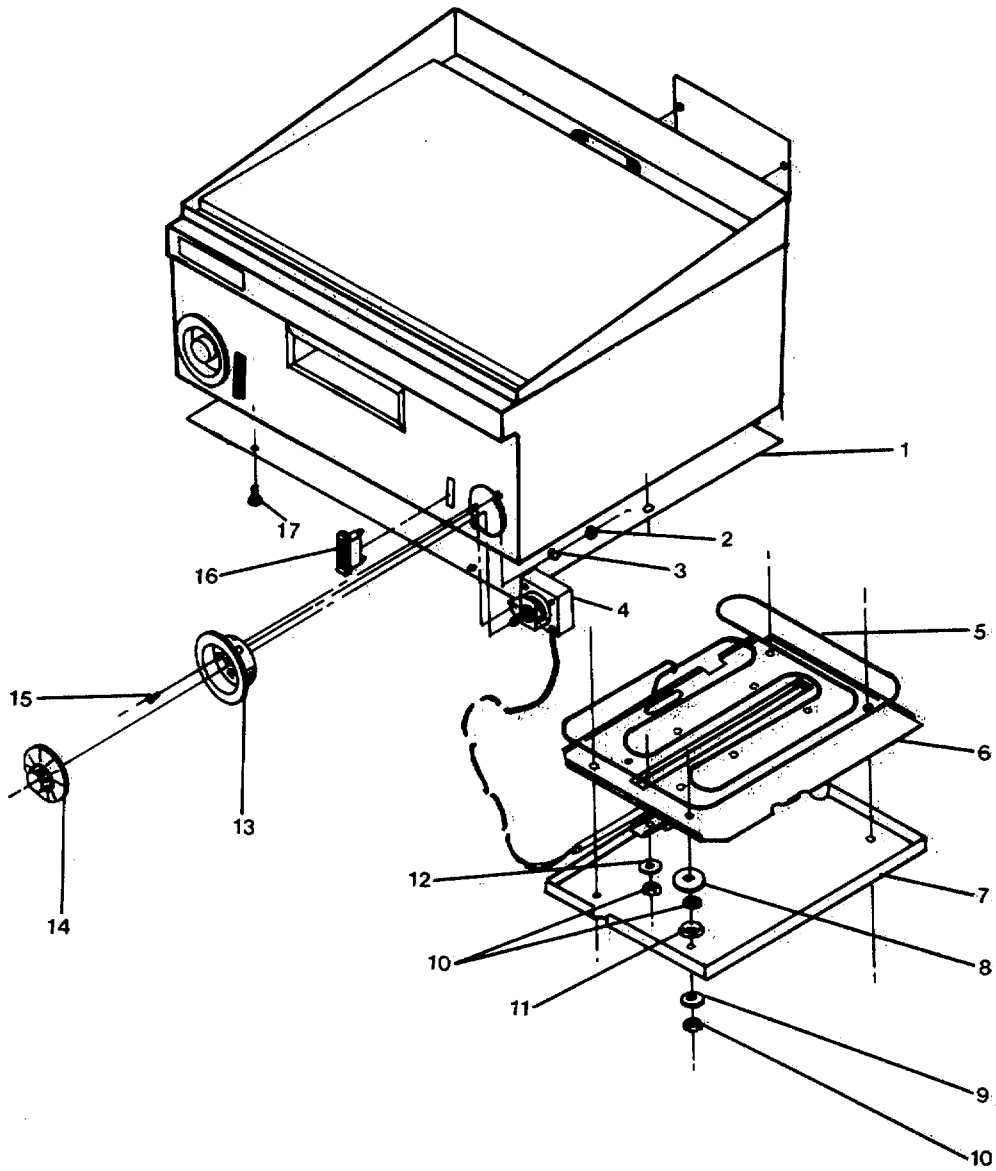

FIGURE 3-63. Repair Self-Heating Griddle.



- n. Remove element clamp plate (6).
- o. Tag and disconnect electrical leads to electrical heating element (5).
- p. Remove electrical heating element.

## REPAIR

Repair at this level of maintenance is by replacement of knob (14), thermostatic control (4), indicator light (16), electrical heating element (5).

## ASSEMBLY

- a. Remove tags and connect electrical leads to electrical heating element (5).
- b. Attach clamp plate (6) over electrical heating element with hexagon nuts (10) and flat washers (8) and eyelet (11).
- c. Install thermostatic control probe and attach with hexagon nuts (10) and cup washers (12).
- d. Attach baffle (7) with hexagon nuts (10) and washers (9).
- e. Remove tags and attach electrical leads to indicator light (16).
- f. Push indicator light into position through opening in front panel.
- g. Position temperature control (4) through opening in front panel, push on control mounting cup (13) and attach with four machine screws (15), hexagon nuts (2) and lockwashers (3).
- h. Push knob (14) onto handle of thermostatic control (4).
- i. Attach case bottom (1) with six machine screws (17).

---

**3-62. Repair Electric Food Mixing Machine. (Figure 3-64)**

---

This task covers:

a. Disassembly

b. Repair

c. Assembly.

---

**INITIAL SETUP:**

Tools

Tool kit, general mechanic's,  
5180-00-699-5273  
Tool kit, electrician's,  
5180-00-391-1087

Equipment Condition

Electric food mixing machine,  
removed, para. 2-56 .  
Mechanical transmission and motor  
removed, para. 2-57 .

Materials/Parts

Stop timer P/N M1-1957  
Gasket P/N M2-3427  
Preformed packing P/N M1-15141  
Encased plain seal P/N M1-15143  
Bevel gear P/N M-1252  
Alternating current motor  
P/N M1-15117  
Warning tags, Item 1, Appendix C

---

**DISASSEMBLY**

- a. Remove self-locking nut (1) and lockwasher (2) from motor shaft (9).
- b. Remove bevel gear (3), encased plain seal (4), spacer (5), washer (6), and key (8) from motor shaft.
- c. Remove preformed packing (7) and gasket (10) from motor.
- d. Remove stop timer (12) by pulling from shaft.

**REPAIR**

Repair at this level of maintenance is by replacement of stop timer (12), gasket (10), preformed packing (7), encased plain seal (4), bevel gear (3), and alternating current motor (11).

**ASSEMBLY**

- a. Install gasket (10) and preformed packing (7) on alternating current motor (11).

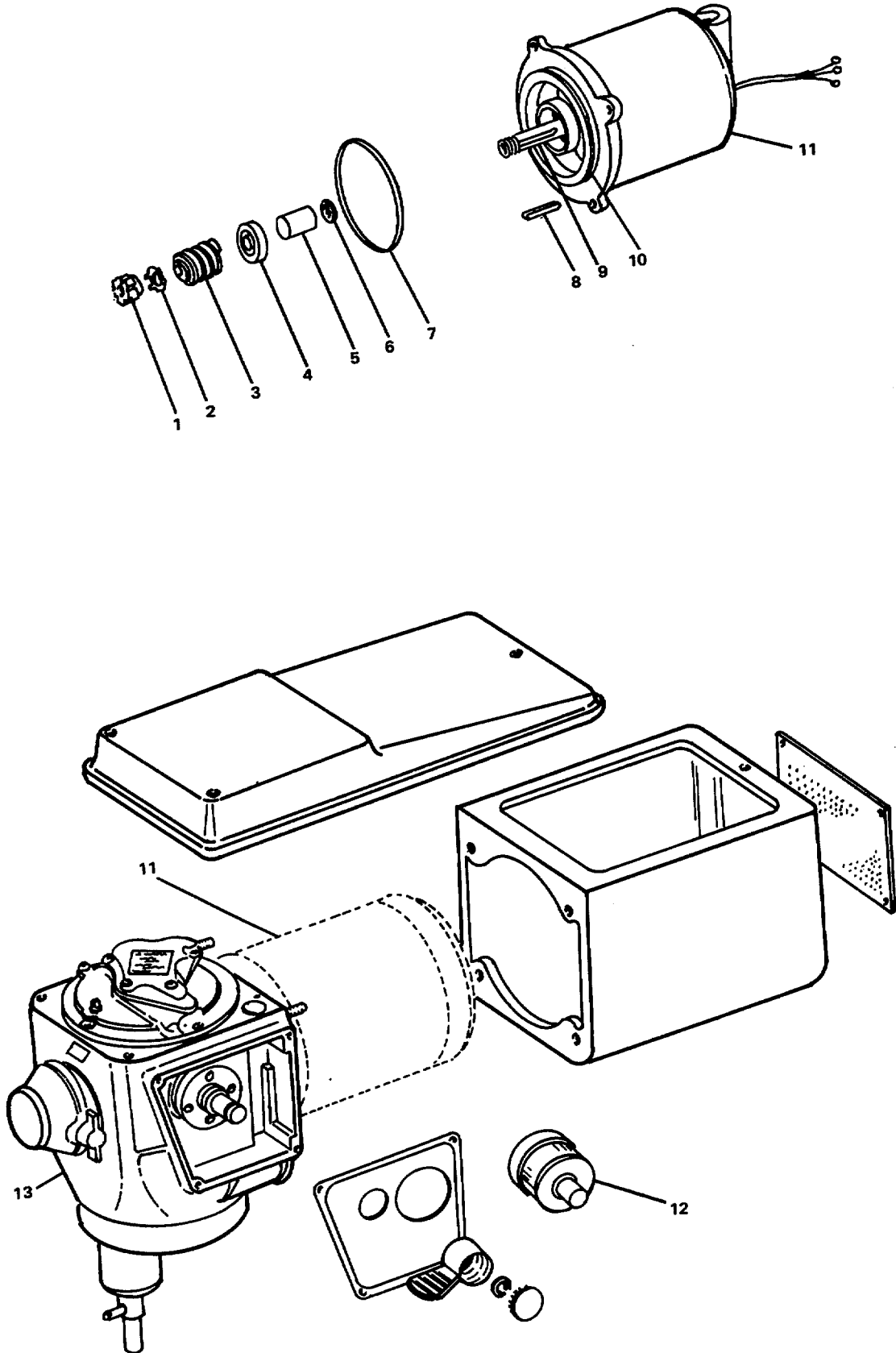

FIGURE 3-64 Repair Electric Food Mixing Machine.

- b. Install key (8), washer (6), spacer (5), encased plain seal (4) and bevel gear (3) on motor shaft (9).
- c. Install lockwasher (2) and self-locking nut (1).
- d. Install timer (12) on shaft.
- e. Refer to paragraph 2-57 to install motor (11) on mechanical transmission (13).

**3-63. Repair Mechanical Transmission (Figure 3-65)****This task covers:**

- |                    |                       |                  |
|--------------------|-----------------------|------------------|
| <b>a. Removal</b>  | <b>b. Disassembly</b> | <b>c. Repair</b> |
| <b>d. Assembly</b> | <b>e. Replacement</b> |                  |

**INITIAL SETUP:**Tools

Tool kit, general mechanic's,  
5180-00-699-5273  
Arbor press, 4920-00-373-9376  
removed, para. 2-58 .

Equipment Condition

Alternating current motor and  
transmission removed, para. 2-57 .  
Technical transmission housing cover

Materials/Parts

Encased plain seal P/N M1-15314  
Preformed packing\_P/N M0-17384  
Shouldered shaft P/N M2-1262-G  
Shouldered shaft P/N M2-1250-D  
Threaded straight pin P/N MI-1396-A  
Encased plain seal P/N W1-12561  
Preformed packing P/N M0-17381  
Cam and gear shouldered shaft  
P/N M2-3332-D

**DISASSEMBLY**

- a. Remove machine screws (4, Sheet 2) and bearing cover (5).
- b. Remove cam and gear shouldered shaft (1, Sheet 1) and preformed packing (2) from inside mechanical transmission housing (3).
- c. Remove cap (7, Sheet 2) and encased plain seal (8).
- d. Remove special screw (6) from hub (9). Remove hub.
- e. Remove bushing (11) and preformed packing (10).

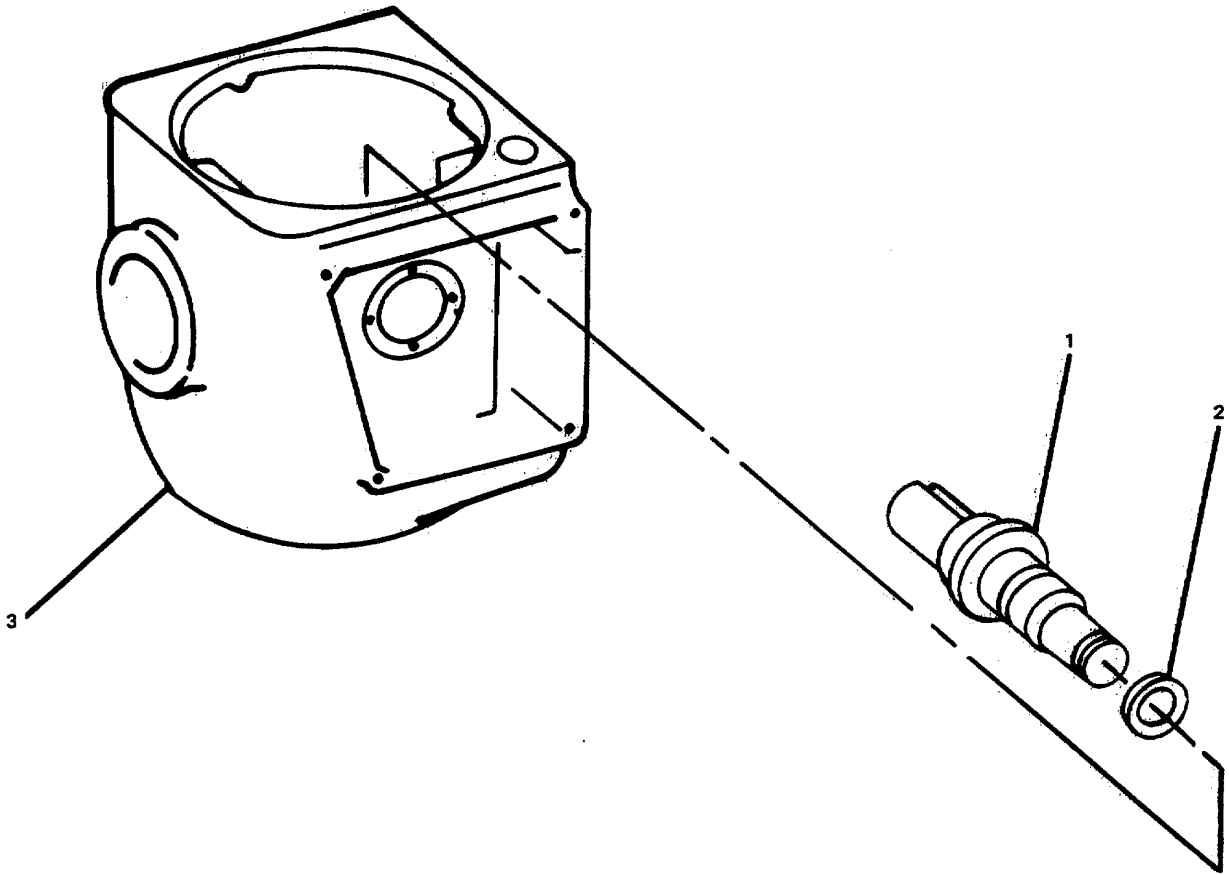

FIGURE 3-65 Repair Electric Food Mixer Transmission (Sheet 1 of 3).

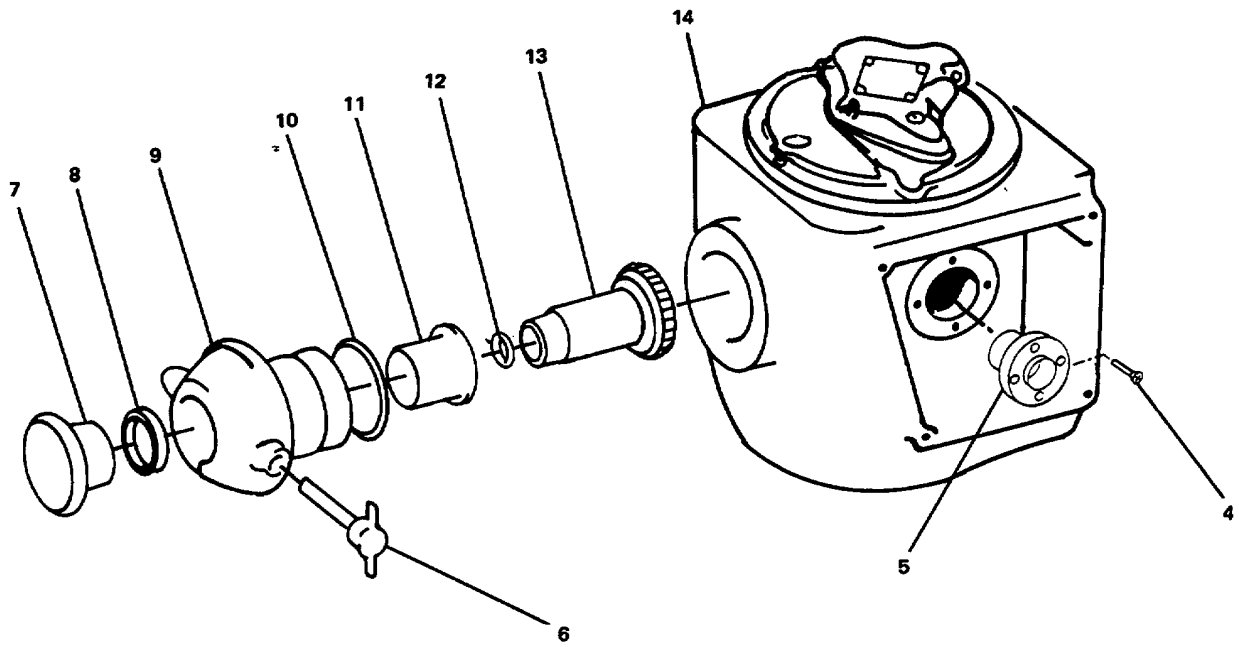

FIGURE 3-65. Repair Electric Food Mixer Transmission (Sheet 2 of 3).

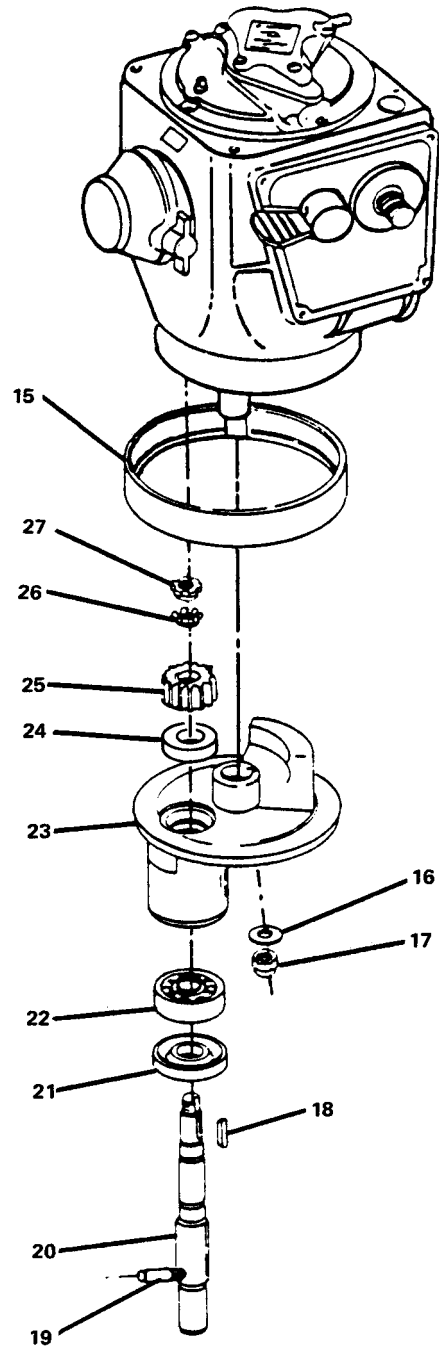

FIGURE 3-65 *Repair Electric Food Mixer Transmission (Sheet 3 of 3)*



- f. Remove shouldered shaft (13) and expansion plug (12) from inside housing (14).
- g. Remove drop ring (15, Sheet 3).
- h. Remove stop nut (17) and flat washer (16).
- i. Remove shaft support (23) and shouldered shaft (20).
- j. Remove lock nut (27) and lockwasher (26).
- k. Remove threaded straight pin (19).
- l. Using an arbor press, press shouldered shaft (20), planet pinion (25), bearing (24), and key (18) from shaft support (23).
- m. Press bearing (22) and seal (21) from shouldered shaft.

## REPAIR

Repair at this level of maintenance is by replacement of: encased plain seal (8, Sheet 2), preformed packing (10), shouldered shaft (13), shouldered shaft (20, Sheet 3), threaded straight pin (19), encased plain seal (21), preformed packing (2, Sheet 1), cam and gear shouldered shaft (1).

## ASSEMBLY

- a. Using an arbor press, press bearing (22, Sheet 3) on shouldered shaft (20).
- b. Install key (18), bearing (24), planet pinion (25) on shouldered shaft and press into shaft support (23).
- c. Coat seal (21) with liquid gasket material and install (cup side up).
- d. Install threaded straight pin (19).
- e. Install lockwasher (26) and lock nut (27).
- f. Install shaft support (23) and attach with flat washer (16) and stop nut (17).
- g. Install drop ring (15).
- h. Install shouldered shaft (13, Sheet 2) and expansion plug (12).
- i. Install preformed packing (10) and bushing (11).
- j. Install hub (9) and special screw (6).
- k. Install encased plain seal (8) and cap (7).
- l. Install preformed packing (2, Sheet 1) and shouldered cam and gear shaft (1) into housing (3).

- m. Install bearing cover (5, Sheet 2) and attach with machine screws (4).
- n. Refer to paragraph 2-58 to install internal components in mechanical transmission housing (3).

**3-276**

---

**3-64. Repair Intermediate Shaft Assembly. (Figure 3-66)**

---

**This task covers:****a. Disassembly****b. Repair,****c. Assembly,**

---

**INITIAL SETUP:**ToolsTool kit, general mechanic's,  
5180-00-699-5273Equipment ConditionMechanical transmission internal  
components removed, para. 2-58 .Materials/PartsIntermediate shaft group  
P/N W0-14862**DISASSEMBLY**

- a. Remove bearings (5) from spur gear shaft (1).
- b. Remove retaining ring (4).
- c. Remove spur pinion (3) and spacer (2).
- d. Remove gear (6).
- e. Remove keys (7).
- f. Remove spacer (8).

**REPAIR**

Repair at this level of maintenance is by replacement of worn or defective parts.

**ASSEMBLY**

- a. Install spacer (8) on spur gear shaft (1).
- b. Install keys (7).
- c. Install gear (6).
- d. Install spacer (2) and spur pinion (3).
- e. Install retaining ring (4).

f. Install bearing (5).

g. Assemble mechanical transmission internal components; refer to paragraph 2-58 .

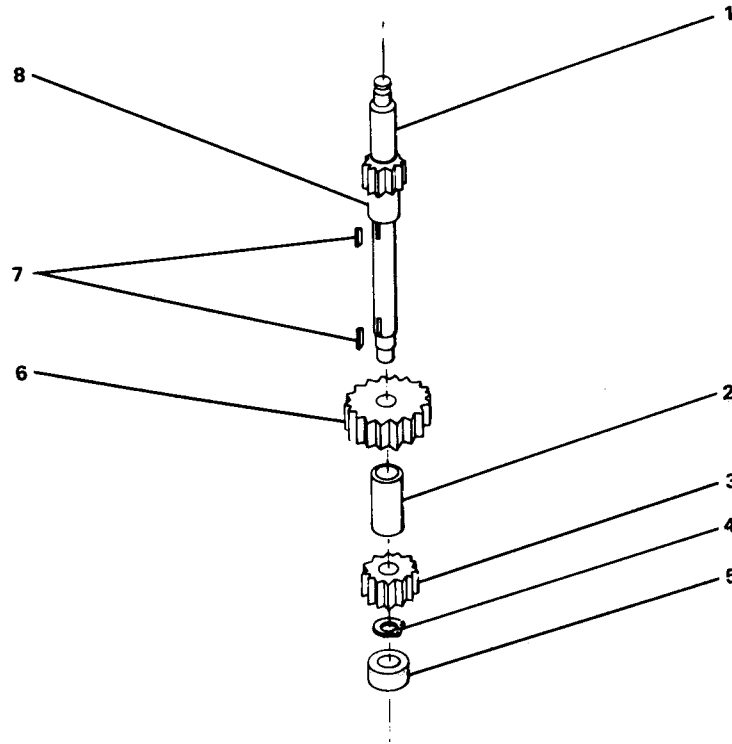

FIGURE 3-66. Repair Intermediate Shaft Assembly.

---

**3-65. Repair Sun Shaft Group. (Figure 3-67)**

---

**This task covers:****a. Disassembly****b. Repair****c. Assembly**

---

**INITIAL SETUP:**Tools

Tool kit, general mechanic's,  
5180-00-699-5273  
Arbor press, 4920-00-373-9376

Equipment Condition

Mechanical transmission internal  
components removed, para, 2-58 .

Materials/Parts

Sun shaft group P/N FIG 410 B RPSTL  
Clutch P/N M1-1934  
Spur gear M2-1258-D  
Encased plain seal P/N M1-15315  
Gear and clutch P/N M2-1259-E  
Shouldered shaft P/N M2-1271-D

---

**DISASSEMBLY**

- a. Remove spacer (1), bearing (2), clutch (22), and spur gear (21) from shouldered shaft (14).
- b. Using an arbor press, press clutch, and bearing from spur gear.
- c. Remove bushing (20).
- d. Using an arbor press, press bevel gear (19) off of shaft (14).
- e. Remove needle bearing (18), gear and clutch (17), thrust bearing (16), clutch (15) from shaft.
- f. Using an arbor press, press bearing (6) from shaft.
- g. Remove encased plain seal (8) and spacer (7).
- h. Remove retaining ring (5).
- i. Remove thrust bearing races (9), needle thrust bearing (10), needle bearing (11), spacer and bushing (12), gear and clutch (13) from shaft.

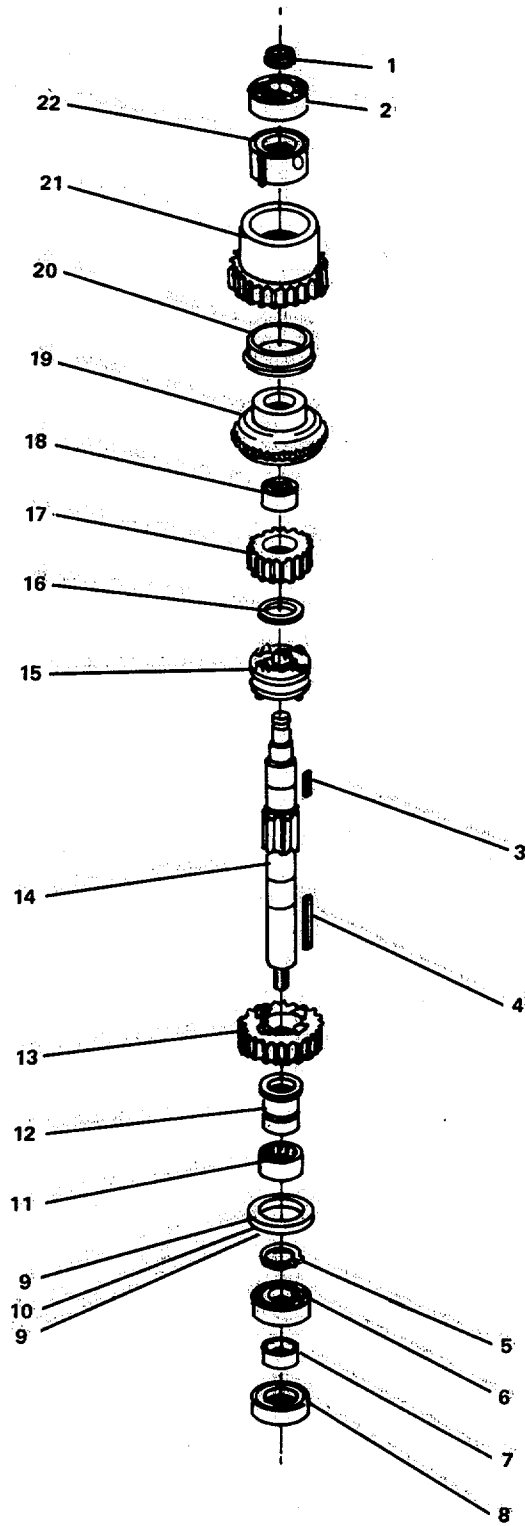

FIGURE 3-67. Repair Sun Shaft Group.

## REPAIR

Repair at this level of maintenance is by replacement of clutch (22), spur gear (21), encased plain bearing (8), gear and clutch (13), and shouldered shaft (14).

## ASSEMBLY

- a. Install gear and clutch (13), spacer and bushing (12) needle bearing (11), needle thrust bearing (10), and thrust bearing races (9) on shouldered shaft (14).
- b. Install retaining ring (5).
- c. Install spacer (7) and encased plain seal (8).
- d. Using an arbor press, press bearing (6) on shaft.

### NOTE

When installing clutch (22) into spur gear (21), arrow on clutch must be visible.

- e. Install clutch (15), thrust bearing (16), gear and clutch (17), and needle bearing (18) on shaft.
- f. Using an arbor press, press bevel gear (19) on shaft.
- g. Install bushing (20).
- h. Using an arbor press, press bearing (2) and clutch (22) into spur gear (21).
- i. Install clutch, bearing, and spur gear on shaft.
- j. Install spacer (1).
- k. Replace mechanical transmission internal components. Refer to paragraph 2-58 .

---

**3-66. Repair Shifter Yoke Assembly. (Figure 3-68)**

---

This task covers:

a. Disassembly

b. Repair

c. Assembly

---

**INITIAL SETUP:**Tools

Tool kit, general mechanic's,  
5180-00-699-5273

Equipment Condition

Mechanical transmission internal  
components removed, para. 2-58 .

Materials/Parts

Shifter yoke assembly P/N M2-3345-B

---

**DISASSEMBLY**

- a. Remove rod (3) from cover (1).
- b. Remove rod from shifter yoke assembly (2).

**REPAIR**

Repair at this level of maintenance is by replacement of worn or defective parts.

**ASSEMBLY**

- a. Install rod (3) into shifter yoke assembly (2).
- b. Install rod into cover (1).
- c. Replace mechanical transmission internal components, refer to paragraph 2-58 .



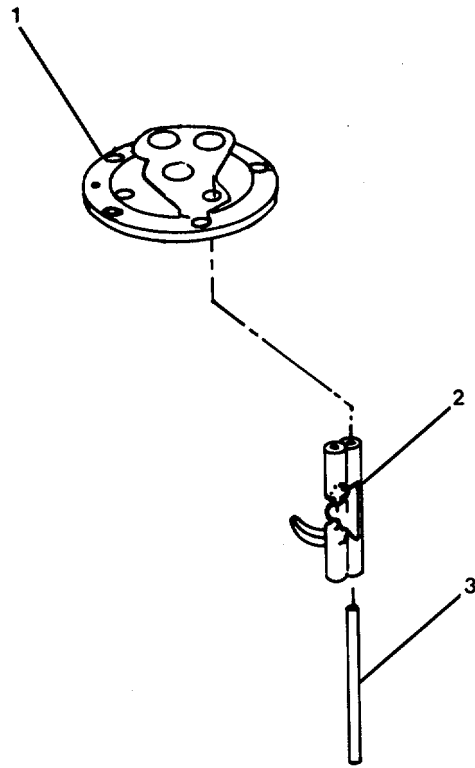

FIGURE 3-68. Repair Shifter Yoke Assembly.

---

**3-67. Repair Pinion Shaft Group. (Figure 3-69)**

---

**This task covers:****a. Disassembly****b. Repair****c. Assembly**

---

**INITIAL SETUP:**Tools

Tool kit, general mechanic's,  
5180-00-699-5273

Equipment Condition

Mechanical transmission internal  
components removed, para. 2-58 .

Materials/Parts

Bevel gear P/N MI-1253-C  
Shouldered shaft P/N M1-1254-C

---

**DISASSEMBLY**

- a. Remove bearing (4) from shouldered shaft (1).
- b. Remove retaining ring (5).
- c. Remove bevel gear (3) and key (2).

**REPAIR**

Repair at this level of maintenance is by replacement of bevel gear (3) and shouldered shaft (1).

**ASSEMBLY**

- a. Install key (2) and bevel gear (3) on shouldered shaft (1).
- b. Install retaining ring (5).
- c. Install bearing (4).
- d. Replace mechanical transmission internal components, refer to paragraph 2-58 .

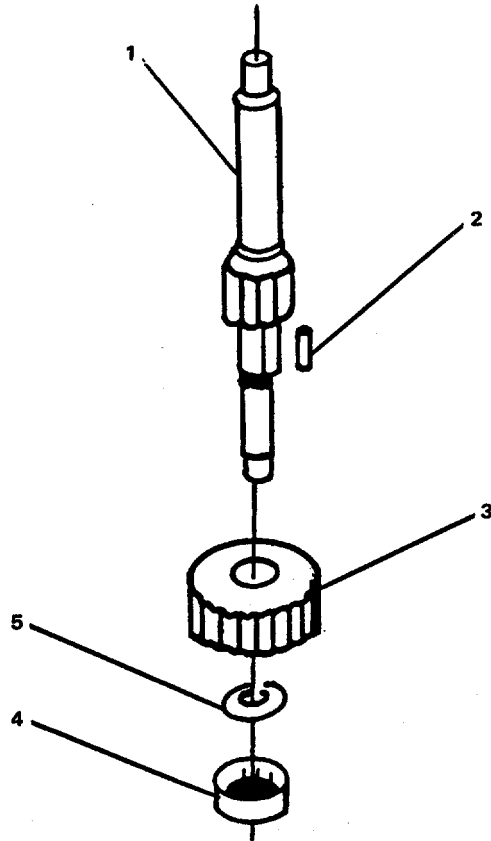

FIGURE 3-69. Repair Pinion Shaft Group.

---

**3-68. Repair Column and Base Assembly. (Figure 3-70)**

---

**This task covers:****a. Disassembly****b. Repair****c. Assembly****INITIAL SETUP:**Tools

Tool kit, general mechanic's,  
5180-00-699-5273

Materials/Parts

Manual lever P/N M1-1344

Equipment Condition

Motor and transmission removed,  
para. 2-57 .  
Column and base assembly removed,  
para. 2-59 .

---

**DISASSEMBLY**

- a. Remove cotter pin (2) and two flat washers (7) from drag link (8) on electric food mixing machine column (5).
- b. Remove drag link from manual lever (3).
- c. Loosen set screws on crank stop (1), manual level (3), and collar (4).
- d. Remove bowl lift lever (6), crank stop, manual lever, and collar.

**REPAIR**

Repair at this level of maintenance is by replacement of manual lever (3).

**ASSEMBLY**

- a. Install bowl lift lever (6), collar (4), manual lever (3), and crank stop (1) on electric food mixing machine column (5).
- b. Tighten set screws on crank stop (1), manual lever (3), and collar (4).
- c. Install drag link (8) in manual lever (3).
- d. Install two flat washers (7) and cotter pin (2).
- e. Refer to paragraph 2-59 to replace column (5) and base assembly.

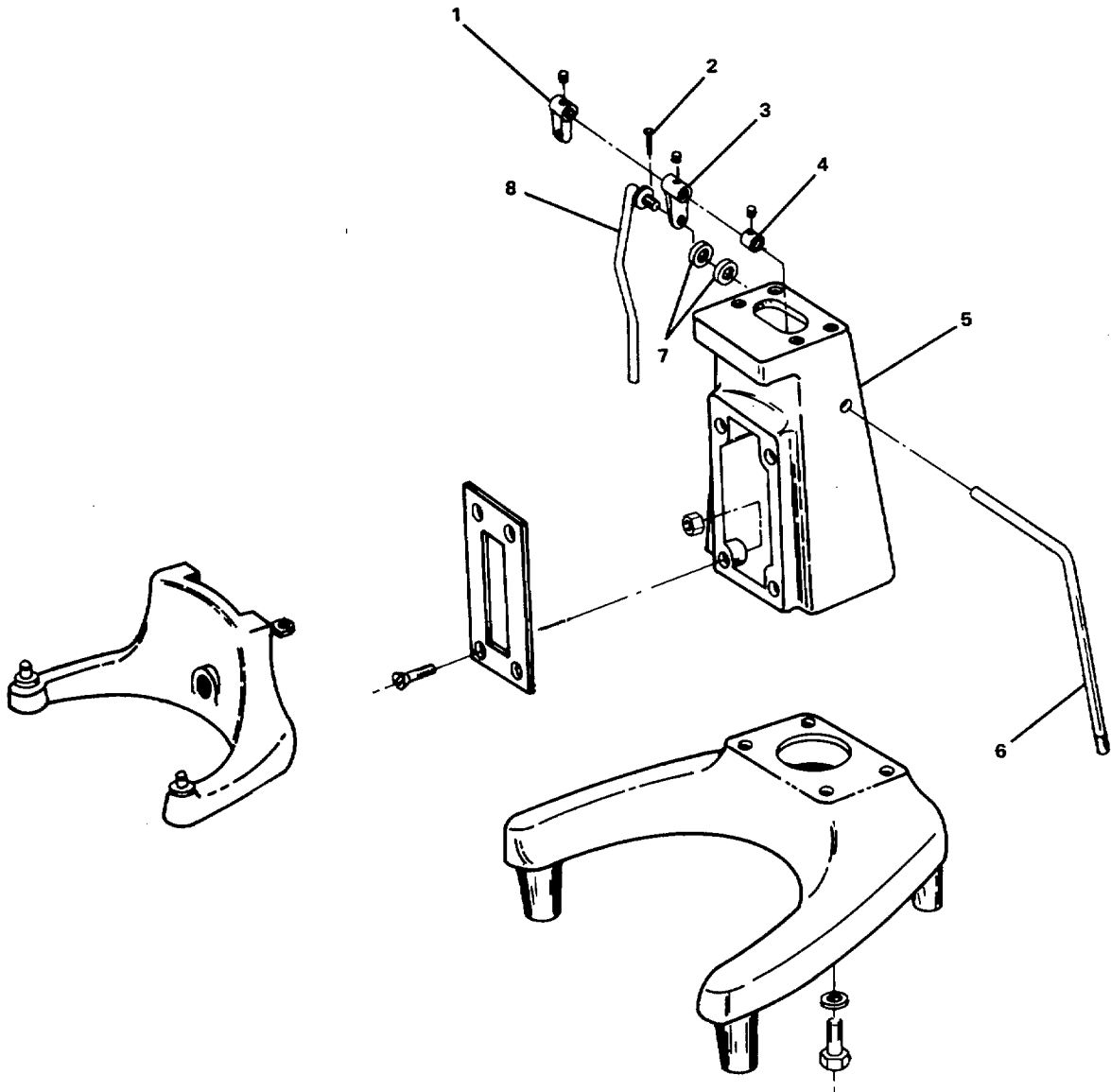

FIGURE 3-70. *Repair Column and Base Assembly.*

---

**3-69. Repair Carriage Unit Assembly. (Figure 3-71)**

---

**This task covers:****a. Disassembly****b. Repair****c. Assembly**

---

**INITIAL SETUP:**Tools

Tool kit, general mechanic's,  
5180-00-699-5273

Equipment Condition

Carriage unit assembly removed,  
para. 2-61 .

Materials/Parts

Carriage unit assembly P/N PL-18497-1

---

**DISASSEMBLY**

- a. Remove thumbscrew (3) and belleville washer (2).
- b. Remove self-tapping screw (10) and slide bar (11).
- c. Remove meat carriage tray (1) from carriage and bushing assembly (4).
- d. Remove self-tapping screw (6) from slide rod (5).
- e. Remove flat washer (7), rubber washer (8), and spring (9).
- f. Remove slide rod (5).
- g. Remove carriage and bushing assembly (4) from base unit assembly.

**REPAIR**

Repair at this level of maintenance is by replacement of worn or defective parts.

**ASSEMBLY**

- a. Install carriage and bushing assembly (4) on base unit assembly.
- b. Install slide rod (5) in carriage and bushing assembly (4).
- c. Install spring (9), rubber washer (8), and flat washer (7).
- d. Install self-tapping screw (6).

- e. Install meat carriage tray (1).
- f. Install slide bar (11) and self-tapping screw (10).
- g. Install belleville washer (2) and thumbscrew (3).
- h. Replace carriage unit assembly; refer to paragraph 2-61 .

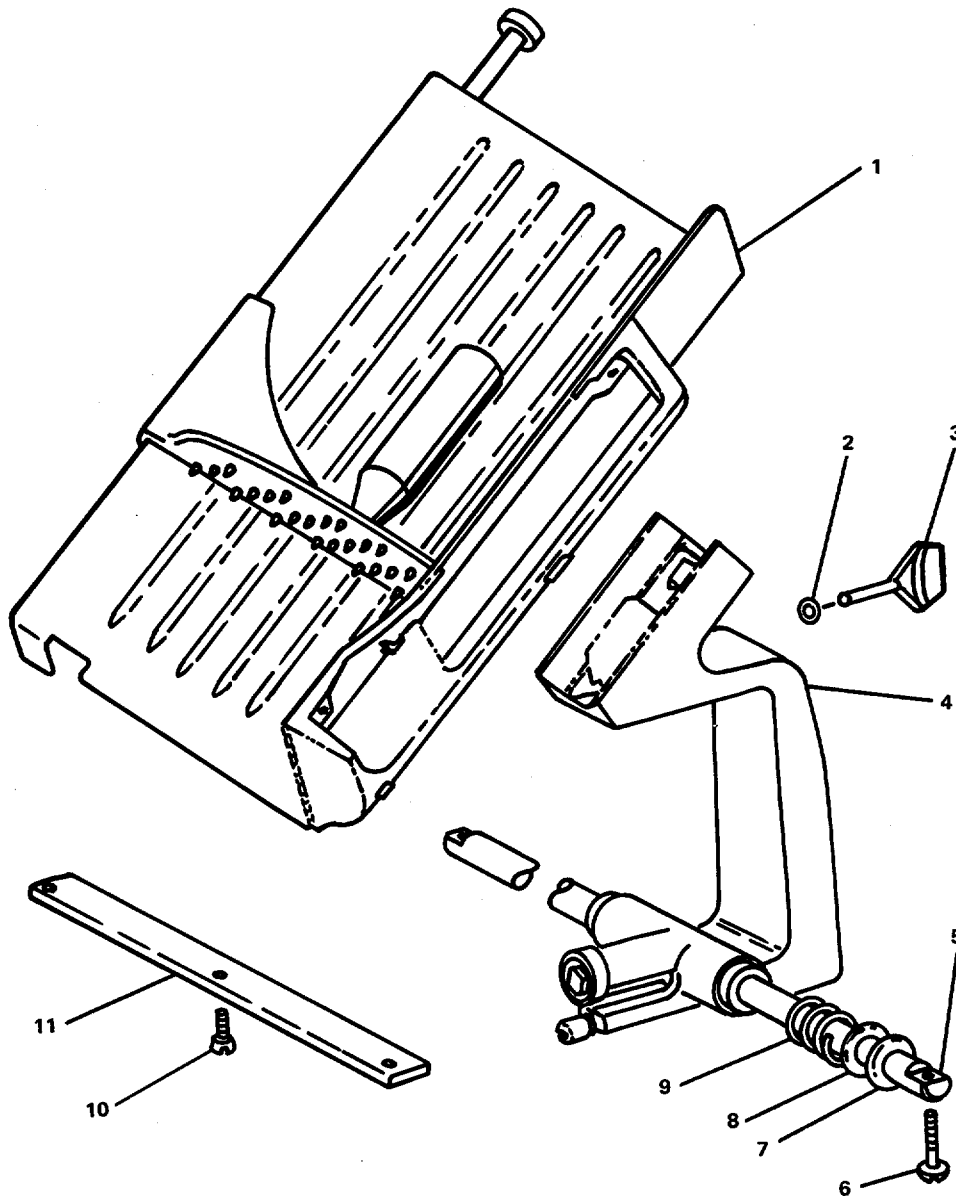

FIGURE 3-71. Repair Carriage Unit Assembly.

**3-70. Repair Knife Unit Assembly. (Figure 3-72)**

**This task covers:**

**a. Disassembly**

**b. Repair**

**c. Assembly**

**INITIAL SETUP:**

Tools

Tool kit, general mechanic's,  
5180-00-699-5273

Materials/Parts

Knife unit assembly P/N PL-16270

Equipment Condition

Knife unit assembly removed,  
para. 2-62 .

Electric meat slicing machine  
removed, para. 2-60 .

**DISASSEMBLY**

- a. Remove knife meat scraper (2).
- b. Remove roll pin (5) and worm gear (6).
- c. Remove rotary meat knife (9), knife shaft ring (8), and knife shaft assembly (7) from knife guard and shaft assembly (1).
- d. Remove machine screw (10) and knife (9) from knife unit assembly (7).
- e. Remove self-tapping screw (4) and drip cup (3).

**REPAIR**

Repair at this level of maintenance is by replacement of worn or defective parts.

**ASSEMBLY**

- a. Install drip cup (3) and attach with self-tapping screw (4).
- b. Install rotary meat knife (9) on knife shaft assembly (7) and attach with machine screw (10).
- c. Install knife shaft assembly (7), knife shaft ring, (8), and rotary meat knife (9) on knife guard and shaft assembly (1).
- d. Install worm gear (6) and roll pin (5).
- e. Install knife meat scraper (2).



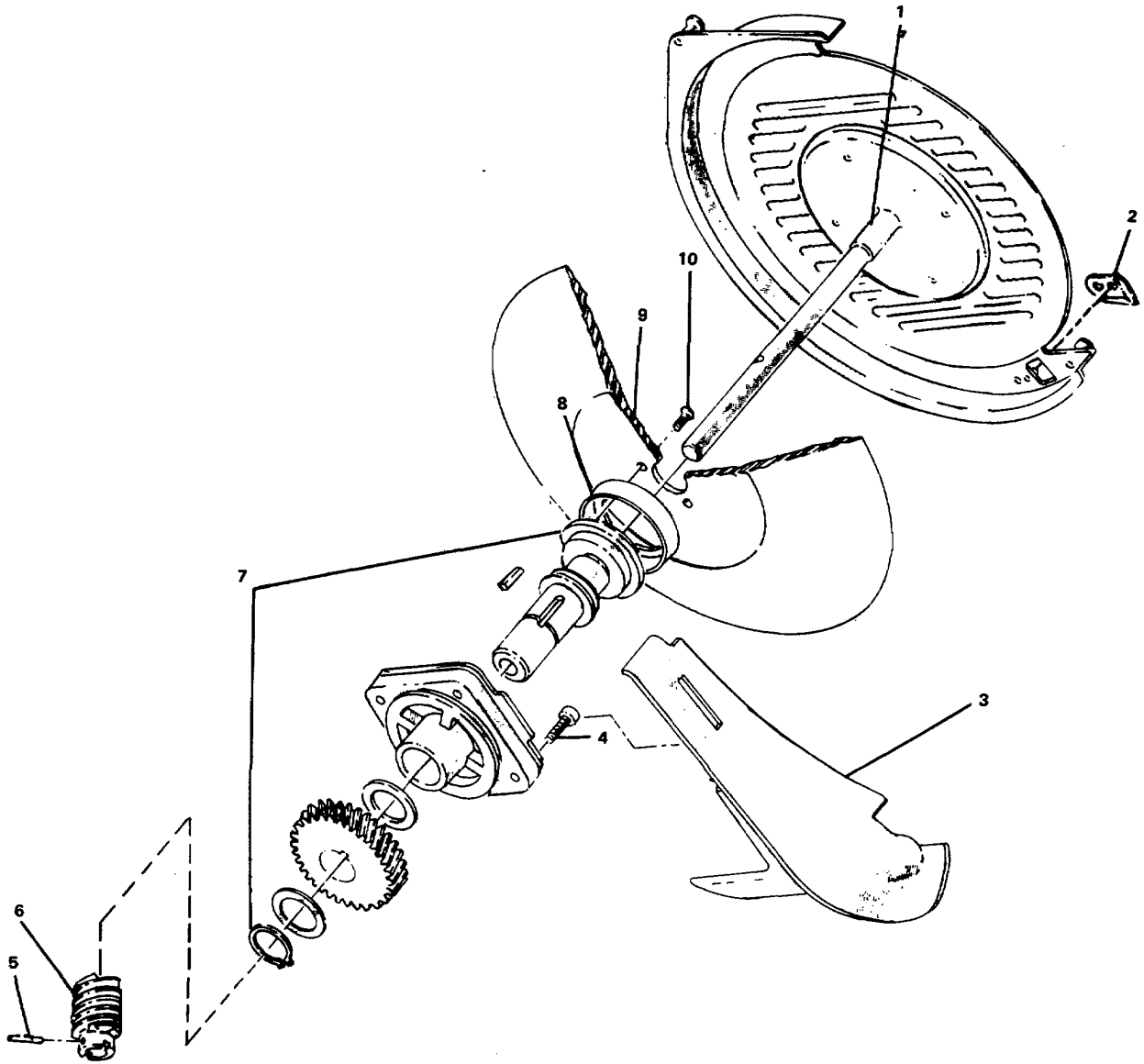

FIGURE 3-72. Replace Knife Unit Assembly.

- f. Replace knife unit assembly; refer to paragraph 2-62 .
- g. Replace electric meat slicing machine; refer to paragraph 2-60 .

**3-71. Repair Gage Plate and Indexing Mechanism and Slide Rod Assembly.**

**This task covers:**

**a. Disassembly**

**b. Repair**

**c. Assembly**

**INITIAL SETUP:**

Tools

Tool kit, general mechanic's,  
5180-00-699-5273

Materials/Parts

Gage plate and indexing mechanism  
P/N PL-13891  
Gage plate and slide rod assembly  
P/N E-118328

Equipment Condition

Electric meat slicing machine  
removed, para. 2-60 .  
Gage plate and indexing mechanism  
removed, para. 2-63 .

**DISASSEMBLY**

Refer to paragraph 2-63 for removal.

**REPAIR**

Repair at this level of maintenance is by replacement of worn or defective parts.

**ASSEMBLY**

Refer to paragraph 2-63 for replacement.

---

**3-72. Repair Base Unit Assembly.**

---

**This task covers:**

**a. Disassembly**

**b. Repair**

**c. Assembly**

---

**INITIAL SETUP:**Tools

Tool kit, general mechanic's,  
5180-00-699-5273

Equipment Condition

Base unit assembly removed,  
para 2-64 .

Materials/Parts

Base unit assembly P/N PL-15572

---

**DISASSEMBLY**

- a. Refer to paragraph 2-64 for removal.

**REPAIR**

Repair at this level of maintenance is by replacement of worn or defective parts.

**ASSEMBLY**

- a. Refer to paragraph 2-64 for replacement.

---

**3-73. Repair Motor. (Figure 3-73)**

---

**This task covers:****a. Disassembly****b. Repair****c. Assembly**

---

**INITIAL SETUP:**Tools

Tool kit, general mechanic's,  
5180-00-699-5273

Equipment Condition

Electric meat slicing machine  
removed, para. 2-60 .  
Motor removed, para. 2-65 .

Materials/Parts

Motor P/N PL-16505-1  
Toggle switch P/N C-111688-4

---

**DISASSEMBLY**

- a. Remove hexagon capscrew (8) and separate motor (9).
- b. Remove spring (1) and annular ball bearing (10).
- c. Remove stator assembly (3).
- d. Remove rotor assembly (2).
- e. Remove toggle switch (7).
- f. Remove self-tapping screw (5) and ball bearing (6) from bracket (4).

**REPAIR**

Repair at this level of maintenance is by replacement of toggle switch (7).

**ASSEMBLY**

- a. Install ball bearing (6) and self-tapping screw (5) in bracket (4).
- b. Install toggle switch (7).
- c. Install rotor assembly (2).
- d. Install stator assembly (3).
- e. Install annular ball bearing (10) and spring (1).

f. Put motor (9) together and secure with hexagon capscrew (8).

g. Refer to paragraphs 2-60 and 2-65 .

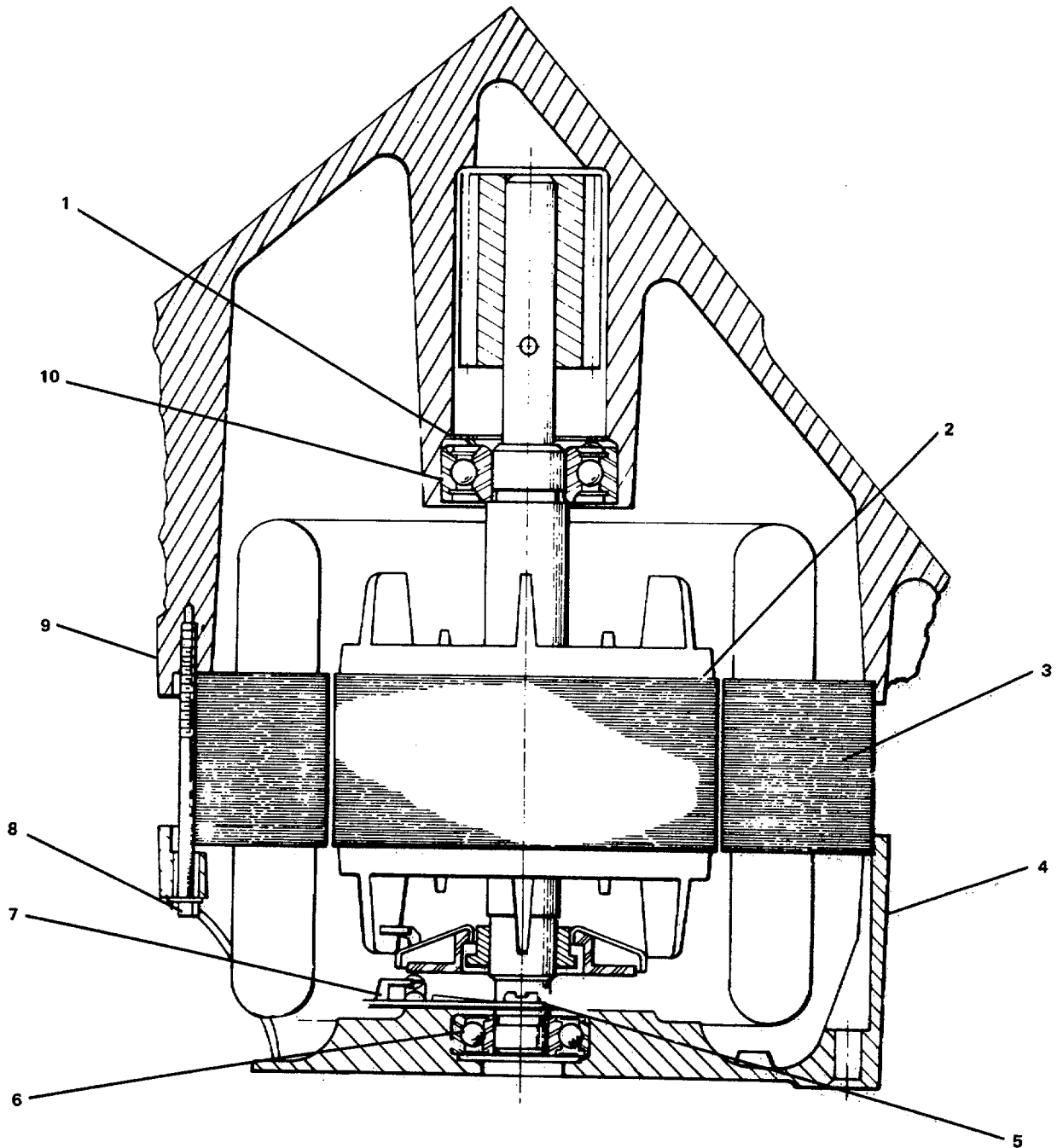

FIGURE 3-73. *Repair Motor.*

---

**3-74. Repair Electrical Unit Assembly.**

---

**This task covers:****a. Disassembly****b. Repair****c. Assembly**

---

**INITIAL SETUP:**ToolsTool kit, general mechanic's,  
5180-00-699-5273Tool kit, electrician's,  
5180-00-391-1087Equipment ConditionElectric meat slicing machine  
removed, para. 2-60 .Electrical unit assembly removed,  
para. 2-66 .Materials/Parts

Electrical unit assembly P/N PL-16269

Capacitor P/N D-70487-15

Electrical switch P/N B-87711-148-1

Warning tags, Item 1, Appendix C

---

**DISASSEMBLY**

- a. Refer to paragraph 2-66 for removed.

**REPAIR**

Repair at this level of maintenance is by replacement of capacitor (8, Figure 2- 55) and electrical switch (15).

**ASSEMBLY**

- a. Refer to paragraph 2-66 for replacement.

**3-75. Repair Knife Sharpener Unit Assembly.**

**This task covers:**

**a. Disassembly**

**b. Repair**

**c. Assembly**

**INITIAL SETUP:**

Tools

Tool kit, general mechanic's,  
5180-00-699-5273

Materials/Parts

Knife sharpener unit P/N PL-13892

Equipment Condition

Electric meat slicing machine  
removed, para. 2-60 .  
Knife sharpener unit removed,  
para. 2-67 .

**DISASSEMBLY**

- a. Refer to paragraph 2-67 for replacement.

**REPAIR**

Repair at this level of maintenance is by replacement of worn or defective parts.

**ASSEMBLY**

- a. Refer to paragraph 2-67 for replacement.



---

**3-76. Repair R-20 Refrigerator. (Figure 3-74)**

---

**This task covers:****a. Disassembly****b. Repair****c. Assembly**

---

**INITIAL SETUP:**ToolsTool kit, general mechanic's,  
5180-00-699-5273Tool kit, electrician's,  
5180-00-391-1087Equipment Condition

Refrigerator removed, para. 2-68 .

Materials/PartsRefrigerator P/N R20-2M-S

---

**DISASSEMBLY**

- a. Remove thermometer (1).
- b. Remove light switch (10).
- c. Remove latch assembly (9).
- d. Remove access door hinge (8).
- e. Remove pilaster clip (5).
- f. Remove shelf (4).
- g. Remove pilaster (6).
- h. Remove lamp shield (2).
- i. Remove lamp socket (3).
- j. Remove gasket (11).
- k. Remove condensation evaporator (7) tray from condenser unit (13) by disconnecting electrical plug on front of pan unit and pulling tray out of frame clip.
- l. Remove condensate heater (12).

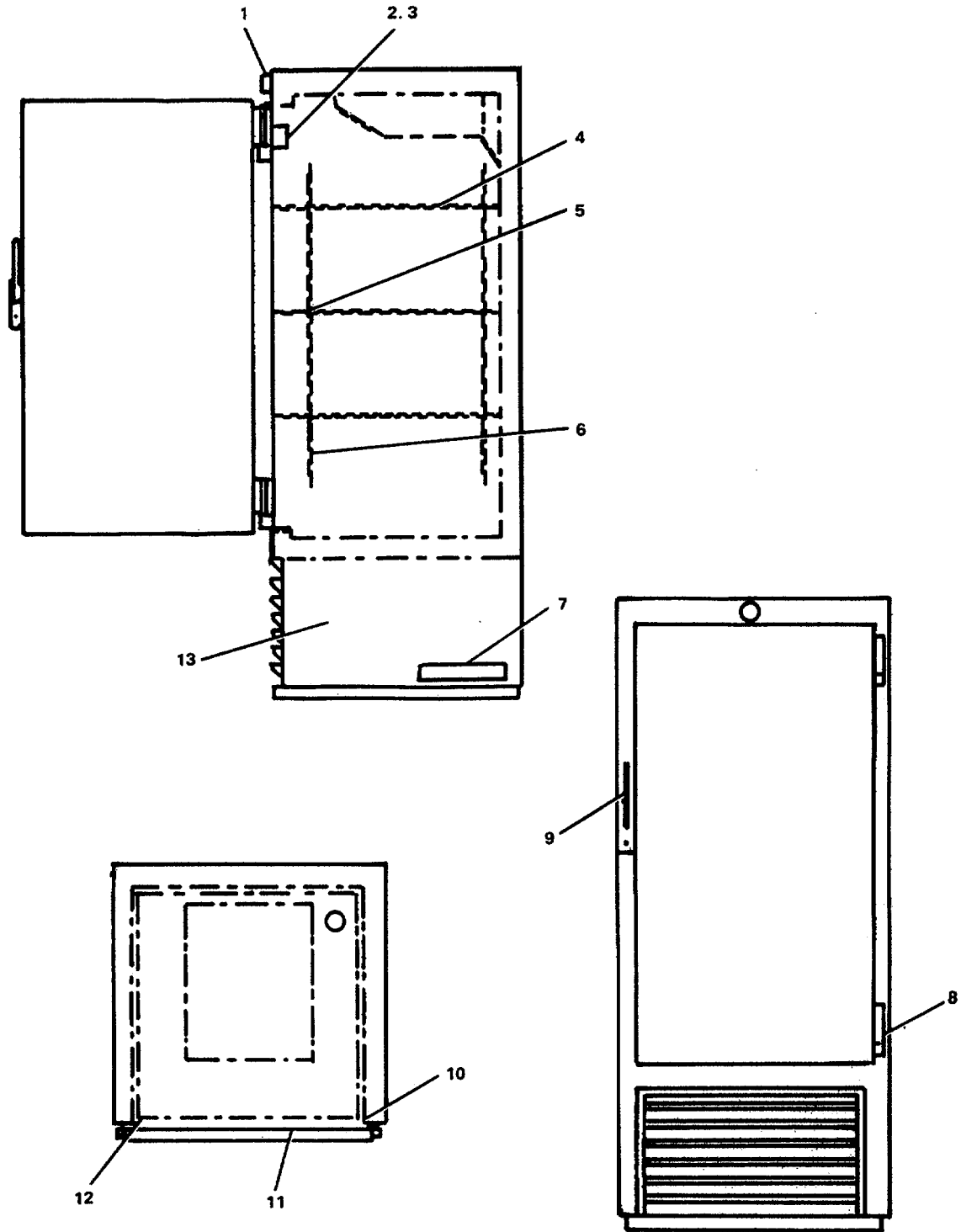

FIGURE 3-74. *Repair R-20 Refrigerator.*

## REPAIR

Repair at this level of maintenance is by replacement of worn or defective parts.

## ASSEMBLY

- a. Install condensate heater (12).
- b. Install condensation evaporator (7) tray in condenser unit (13) by installing in frame clip and connecting electrical plug.
- c. Install gasket (11).
- d. Install light switch (10).
- e. Install light socket (3).
- f. Install lamp shield (2).
- g. Install pilaster (6).
- h. Install shelf (4).
- i. Install pilaster clip (50).
- j. Install access door hinge (8).
- k. Install latch assembly (9).
- l. Install thermometer (1).
- m. Refer to paragraph 2-68 .

---

**3-77. Repair R-20 Refrigerator - Refrigeration Condenser. (Figure 3-75)**

---

**This task covers:****a. Disassembly****b. Repair****c. Assembly**

---

**INITIAL SETUP:**Tools

Tool kit, general mechanic's,  
5180-00-699-5273

Equipment Condition

Refrigerator removed, para. 2-68 .  
Condenser unit and base removed,  
para. 2-69 .

Materials/Parts

Refrigeration condenser  
P/N AE4430A

---

**DISASSEMBLY****WARNING**

PRESSURIZED GAS HAZARD. Make sure system refrigerant charge pressure has been relieved before removing system components.

- a. To remove compressor (4), perform the following.
- (1) Sweat off suction end discharge refrigerant lines.
  - (2) Tag and disconnect electrical lines.
  - (3) Remove compressor mounting bolts

**CAUTION**

Handle with care. This unit is heavy and awkward to handle.

- (4) Remove compressor from base.
- b. To remove condenser fan motor (9), perform the following.
- (1) Disconnect electrical plug.
  - (2) Remove condenser fan motor mounting bolts.
  - (3) Remove condenser fan motor and impeller fan (1) from condenser unit.
- c. Remove axial fan impeller (1) by snapping off fan motor shaft.

**WARNING**

ELECTRIC SHOCK HAZARD. Ensure the electrolytic (starter) capacitor leads are shorted together to discharge the capacitor before disassembly.

- d. Remove electrolytic fixed capacitor (8) electrical lead quick disconnect and remove capacitor.
- e. Disconnect and tag electromagnetic relay (7) electrical leads and retaining screw, and remove relay.
- f. Disconnect and tag circuit breaker (6) electrical leads and retaining screw and remove circuit breaker.
- g. Sweat off refrigerant lines to each side of filter dryer (2) and remove filter dryer.
- h. To remove liquid sight indicator (3), sweat refrigerant lines off each side of unit and remove.
- i. Disconnect and tag low level control (5) electrical leads and retaining screw and remove low level control.

**REPAIR**

Repair at this level of maintenance is by replacement of worn or defective parts.

**ASSEMBLY**

- a. Install low level control (5) in control panel with retaining screw, remove tags, and connect electrical leads.
- b. Sweat on liquid sight indicator (3) refrigerant connections.
- c. Sweat on filter dryer (2) refrigerant connections.
- d. Install circuit breaker (6) with retaining screw, remove tags, and connect electrical leads.
- e. Install electromagnetic relay (7) with retaining screw, remove tags, and connect electrical leads.
- f. Install electrolytic fixed capacitor (8) in mount and connect electrical lead quick disconnect.
- g. Snap on axial fan impeller (1) on condenser fan motor (9) shaft.
- h. To install condenser fan motor (9), perform the following:
  - (1) Install condenser fan motor and impeller fan (1) in condenser unit.
  - (2) Install condenser fan motor mounting bolts.

(3) Connect electrical plug.

i. To install compressor (4), perform the following:

**CAUTION**

Handle with care. This unit is heavy and awkward to handle.

- (1) Install compressor on base.
- (2) Install compressor mounting bolts.
- (3) Remove tags and connect electrical lines.
- (4) Sweat on suction and discharge refrigerant lines.

j. Refer to paragraph 2-68 .

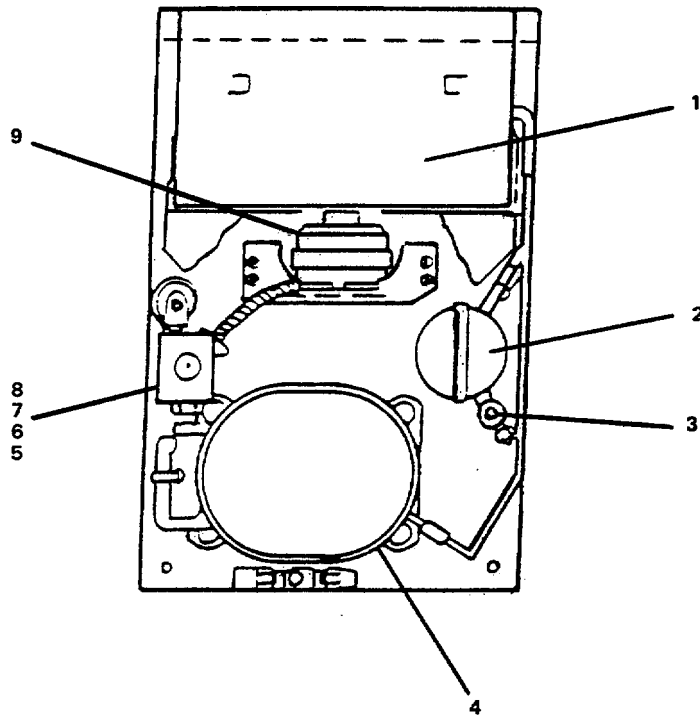

FIGURE 3-75. Repair Refrigeration Condenser.

---

**3-78. Repair R-20 Refrigerator - Refrigeration Evaporator Coil. (Figure 3-76)**

---

**This task covers:****a. Disassembly****b. Repair****c. Assembly**

---

**INITIAL SETUP:**ToolsTool kit, general mechanic's,  
5180-00-699-5273Tool kit, electrician's,  
5180-00-391-1087Equipment ConditionR-20 refrigerator removed, para. 2-68 .  
Evaporator coil removed, para. 2-70 .Materials/PartsRefrigeration evaporator coil  
P/N TA-130 for R-20 refrigeratorRefrigeration evaporator coil  
P/N TA-170 for R-30 refrigerator

---

**DISASSEMBLY**

- a. Remove machine screws (2) and hanging bracket (1).
- b. Remove machine screw (3).
- c. Remove coil assembly (5) from top housing (3).

**REPAIR**

Repair at this level of maintenance is by replacement of worn or defective parts.

**ASSEMBLY**

- a. Install coil assembly (5) in top housing (3).
- b. Install machine screw (3).
- c. Install hanging bracket (1) with machine screws (2).
- d. Refer to paragraph 2-70.

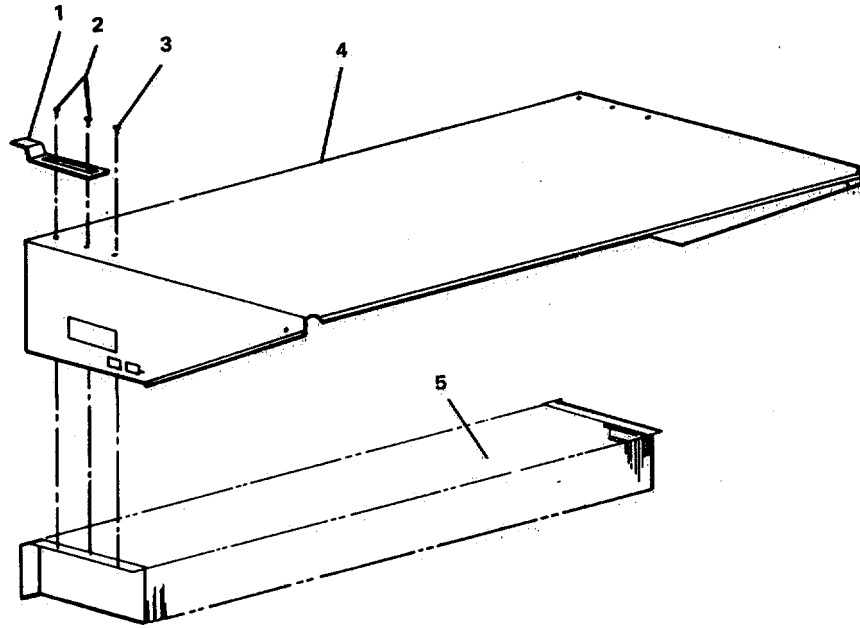

FIGURE 3-76. Repair Refrigerator - Refrigeration Evaporator Coil.



---

**3-79. Repair F-20 Mechanical Food Freezer. (Figure 3-77)**

---

**This task covers:****a. Disassembly****b. Repair****c. Assembly**

---

**INITIAL SETUP:**ToolsTool kit, general mechanic's,  
5180-00-699-5273Tool kit, electrician's,  
5180-00-391-1087Equipment Condition

Mechanical freezer removed, para. 2-71 .

Materials/PartsMechanical freezer P/N F20-2M-ADS

---

**DISASSEMBLY**

- a. Remove thermometer (1).
- b. Remove light switch (10).
- c. Remove latch assembly (9).
- d. Remove access door hinge (8).
- e. Remove pilaster clip (5).
- f. Remove shelf (4).
- g. Remove pilaster (6).
- h. Remove lamp shield (2).
- i. Remove lamp socket (3).
- j. Remove gasket (11).
- k. Remove condensation evaporator (7) from condenser unit (13) by disconnecting electrical plug on front of pan and pulling tray out of frame clip.
- l. Remove condensate heater (12).

**REPAIR**

Repair at this level of maintenance is by replacement of worn or defective parts.

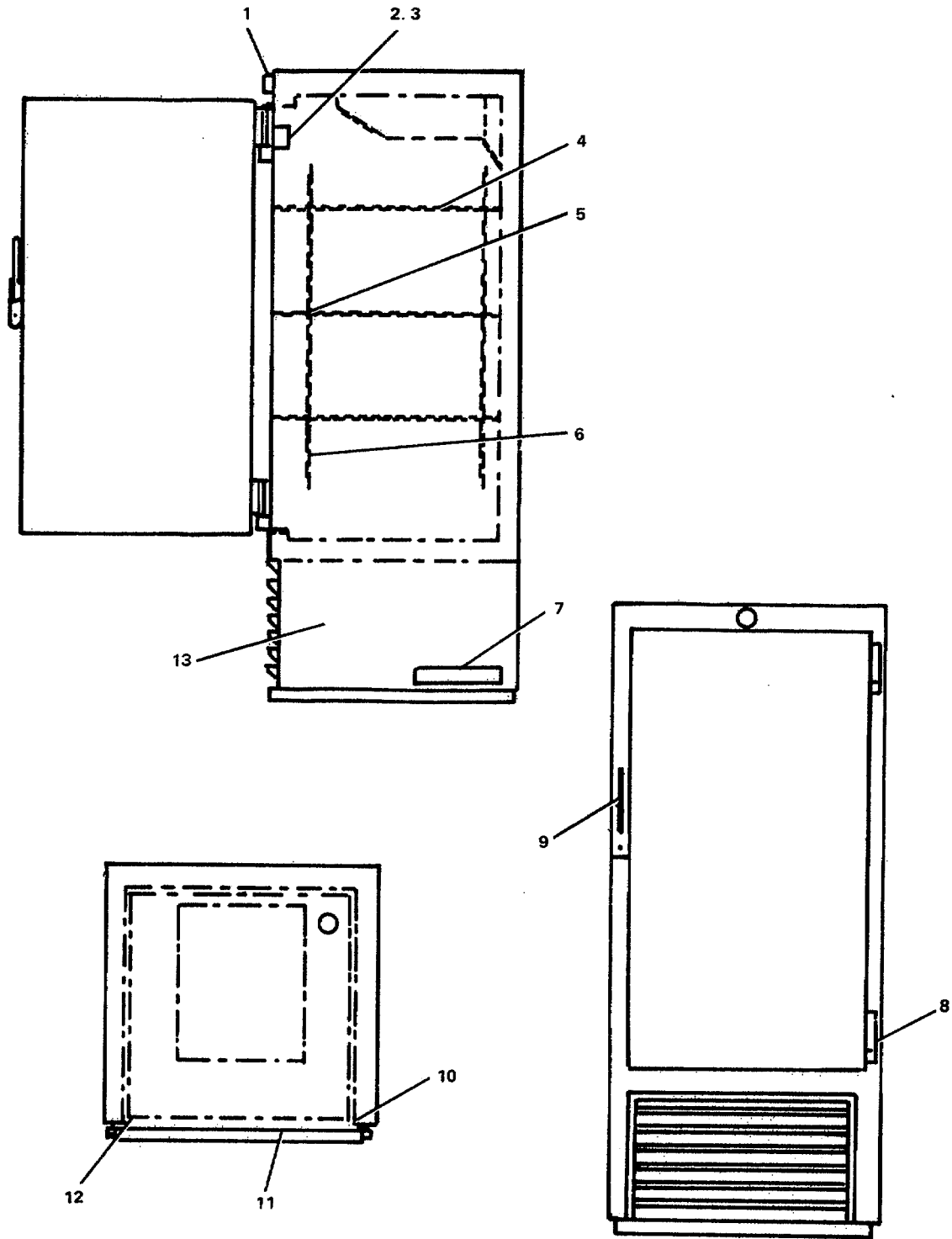

FIGURE 3-77. *Repair F-20 Mechanical Food Freezer.*

---

ASSEMBLY

- a. Install condensate heater (12).
- b. Install condensation evaporator (7) tray in condenser unit (13) by installing tray in frame clip and connecting electrical plug.
- c. Install gasket (11).
- d. Install light switch (10).
- e. Install light socket (3).
- f. Install lamp shield (2).
- g. Install pilaster (6).
- h. Install shelf (4).
- i. Install pilaster clip (5).
- j. Install access door hinge (8).
- k. Install latch assembly (9).
- l. Install thermometer (1).

---

**3-80. Repair F-20 Mechanical Freezer - Refrigeration Condenser. (Figure 3-78)**

---

**This task covers:****a. Disassembly****b. Repair****c. Assembly**

---

**INITIAL SETUP:**ToolsTool kit, general mechanic's,  
5180-00-699-5273Equipment ConditionFreezer removed, para. 2-71 .  
Condenser unit removed, para. 2-72 .Materials/PartsRefrigeration condenser  
P/N AE2415AC

---

**DISASSEMBLY**WARNINGPRESSURIZED GAS HAZARD. Make sure  
system refrigerant charge pressure is relieved  
before removing system components.

- a. To remove the refrigerant compressor (8), perform the following:
- (1) Sweat off the suction and discharge refrigerant lines.
  - (2) Tag and disconnect electrical lines.
  - (3) Remove the compressor mounting bolts.

CAUTIONHandle with care. This unit is heavy and  
awkward to handle.

- (4) Remove compressor from base.
- b. To remove condenser fan motor (9), perform the following.
- (1) Disconnect electrical plug.
  - (2) Remove condenser fan motor mounting bolts.
  - (3) Remove condenser fan motor and impeller fan from condenser unit.

- c. Remove axial fan impeller (10) by snapping off fan motor shaft.

WARNING

ELECTRIC SHOCK HAZARD. Ensure the electrolytic (starter) capacitor leads are shorted together to discharge the capacitor before disassembly.

- d. Remove electrolytic fixed capacitor (3) electrical lead quick disconnect and remove capacitor.
- e. Disconnect and tag relay (7) electrical leads and retaining screws, and remove relay.
- f. Disconnect and tag (4) electrical leads and retaining screw and remove overload.
- g. Sweat off refrigerant lines to each side of filter dryer (1) and remove filter dryer.
- h. To remove liquid sight indicator (2), sweat refrigerant lines off each side of unit and remove.
- i. To remove defrost timer (6), perform the following:
  - (1) Loosen screw on top of timer unit.
  - (2) Pull off timer base cover.
  - (3) Disconnect and tag electrical leads, remove mounting screw and remove defrost timer.
- j. Disconnect and tag thermostat electrical leads, remove mounting screws, and remove thermostat.

REPAIR

Repair at this level of maintenance is by replacement of worn or defective parts.

ASSEMBLY

- a. To install defrost timer (6), perform the following:
  - (1) Install defrost timer with mounting screw in control panel.
  - (2) Remove tags and connect electrical leads.
  - (3) Install press on base cover.
  - (4) Tighten top screw on defrost timer.

- b. Install thermostat (5) mounting screw, remove tags, and connect electrical leads.
- c. Sweat on liquid sight indicator (2) refrigerate connections.
- d. Sweat on filter dryer (1) refrigerant connections.
- e. Install overload (4) with retaining screw, remove tags, and connect electrical leads.
- f. Install relay (7) with retaining screw, remove tags, and connect electrical leads.
- g. Install electrolytic fixed capacitor (3) in mount and connect electrical quick disconnect leads.
- h. Snap on axial fan impeller (10) on condenser fan motor (a) shaft.
- i. To install condenser fan motor (9), perform the following.
  - (1) Install condenser fan motor in condenser unit and install mounting bolts.
  - (2) Connect condenser fan motor electrical plug.
- j. To install compressor (8), perform the following:

CAUTION

Handle with care. This unit is heavy and awkward to handle.

- (1) Install compressor on base.
  - (2) Install compressor mounting bolts.
  - (3) Remove tags and connect electrical lines.
  - (4) Sweat on suction and discharge refrigerant lines.
- k. Refer to paragraph 2-71 .

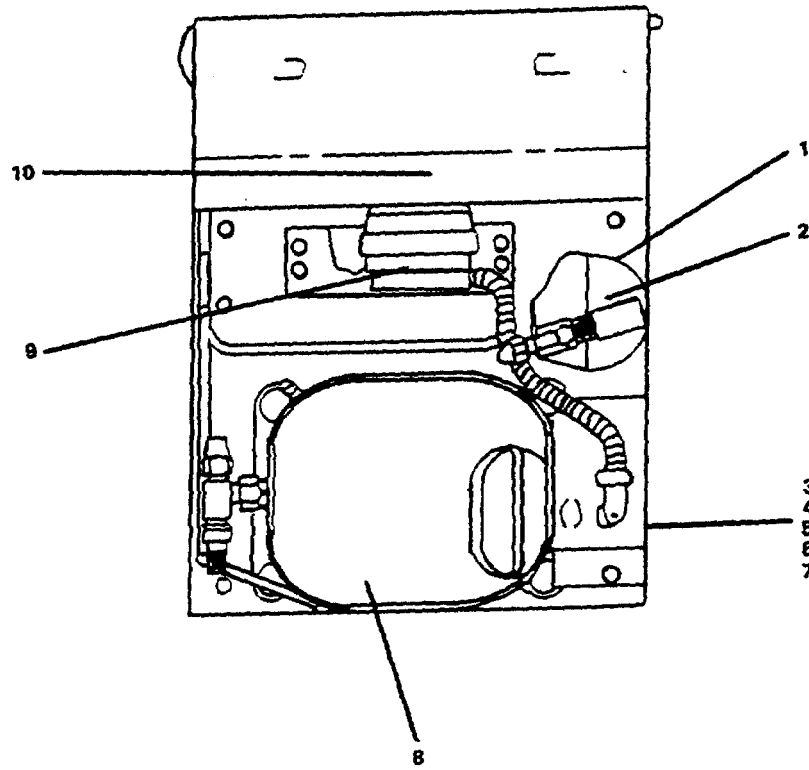

FIGURE 3-78. Repair Refrigeration Condenser.

**3-81. Repair F-20 Mechanical Freezer - Refrigeration Evaporator Coil. (Figure 3-79)****This task covers:****a. Disassembly****b. Repair****c. Assembly**INITIAL SETUP:Tools

Tool kit, general mechanic's,  
5180-00-699-5273  
Tool kit, electrician's,  
5180-00-391-1087

Equipment Condition

Mechanical freezer removed, para 2-71 .

Materials/Parts

Refrigeration evaporator coil  
P/N D20494

DISASSEMBLY

- a. Remove machine screw (17), captive wing screw (15), and lanyard (16).
- b. Remove machine screw (33), tinnerman (30) and bottom housing (18).
- c. Remove machine screw (4), hanger (3) and coil assembly (31).
- d. Remove machine screws (12) and junction box cover (11).
- e. Remove harness lead (5), snap bushing (7) and strain relief (6).
- f. Remove machine screws (2), whiz nut (10), terminal block (9) and junction box (28).
- g. Remove machine screw (13), fan guard (14), fan (20) and motor mount (22).
- h. Remove motor harness (29).
- i. Remove machine screw (19) and motor (21).
- j. Remove heater clip (23) and defrost heater (24).
- k. Remove machine screw (27) and thermostatic switches (26, 25).

REPAIR

Repair at this level of maintenance is by replacement of worn or defective parts.



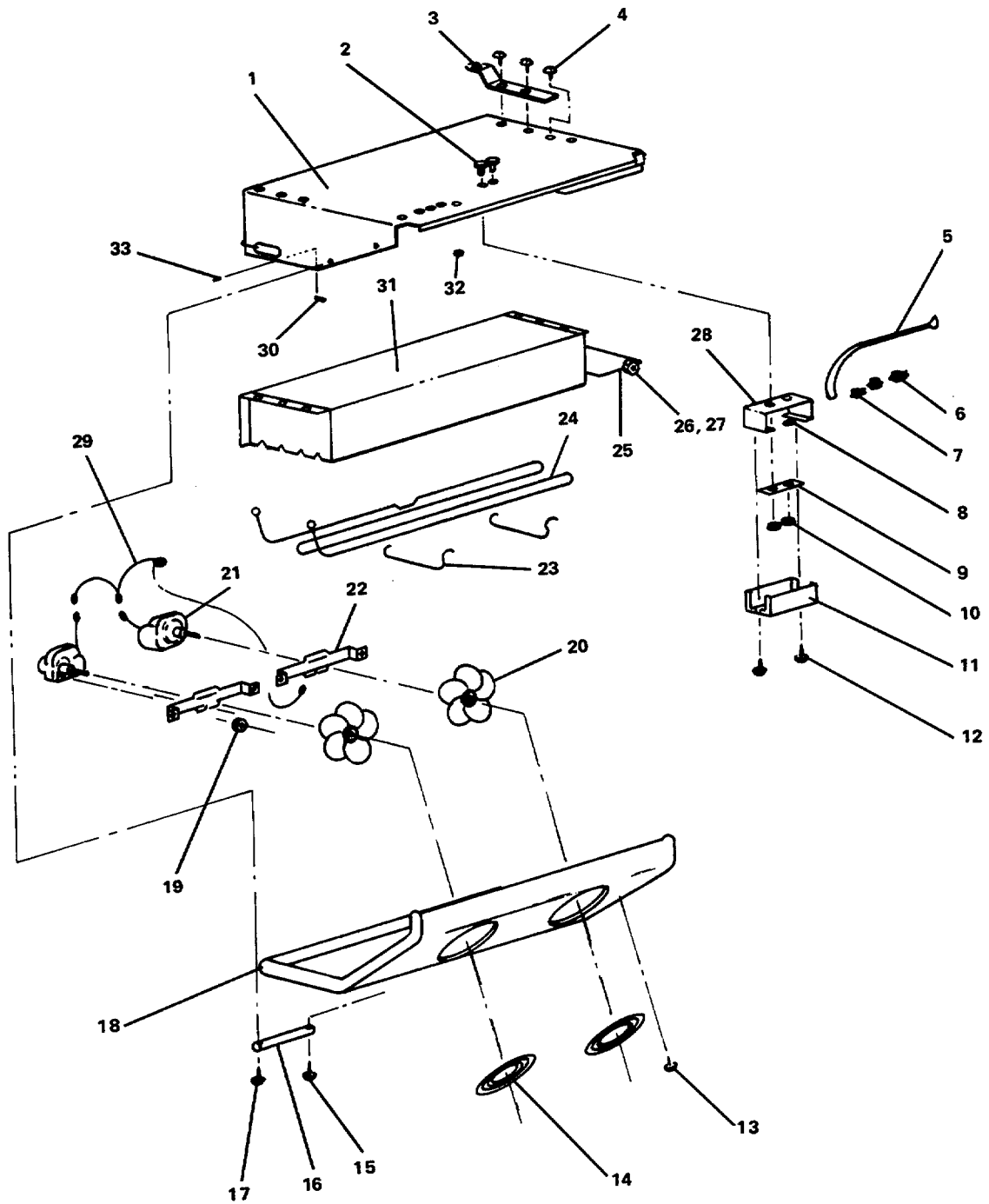

FIGURE 3-79. *Repair F-20 Mechanical Freezer - Refrigeration Evaporator Coil.*

ASSEMBLY

- a. Install thermostatic switches (25, 26) with machine screw (27).
- b. Install defrost heater (24) and heater clip (23).
- c. Install motor (21) with machine screw (19).
- d. Install motor harness (29).
- e. Install motor mount (22), fan (20), fan guard (14), with machine screw (13).
- f. Install junction box (28) and terminal block (9) with whiz nut (10) and machine screw (2).
- g. Install strain relief (6), snap bushing (7), and harness lead (5).
- h. Install junction block cover (11) with machine screws (12).
- i. Install coil assembly (31) and hanger (3) with machine screws (4).
- j. Install bottom housing (18) with tinnerman (30) and machine screw (33).
- k. Install lanyard (16) with captive wing screw (15) and machine screw (17).
- l. Refer to paragraph 2-71 .

**3-82. Repair Garbage Disposal. (Figure 3-80)****This task covers:****a. Disassembly****b. Repair****c. Assembly**INITIAL SETUP:Tools

Tool kit, general mechanic's,  
5180-00-699-5273

Tool kit, electrician's,  
5180-00-391-1087

Equipment Condition

Garbage disposal removed, para. 2-74 .

Materials/Parts

Gasket P/N B10229

Gasket P/N B10204

Gasket P/N B10203

Reset switch P/N B14276

Alternating current motor P/N B14223

Warning tags, Item 1, Appendix C

DISASSEMBLY

- a. Remove plain hexagon nut (6), lockwasher (5), and machine bolt (1).
- b. Remove adapter segments (2) and gasket (3).
- c. Remove plain hexagon nut (7), lockwasher (8), washer (18), and machine bolt (19).
- d. Remove hopper (4) and gasket (9).
- e. Remove fan guard (10).
- f. Remove lock nut (24).
- g. Remove rotor (11), secondary water shield (12), water seal, (13), and spacer (14).
- h. Remove lock ring (15) and top bearing (16).
- i. Remove elbow (20) from drain housing (17).
- j. Remove gasket (23) and drain housing (17) from alternating current motor (21).
- k. Tag and disconnect electrical leads.

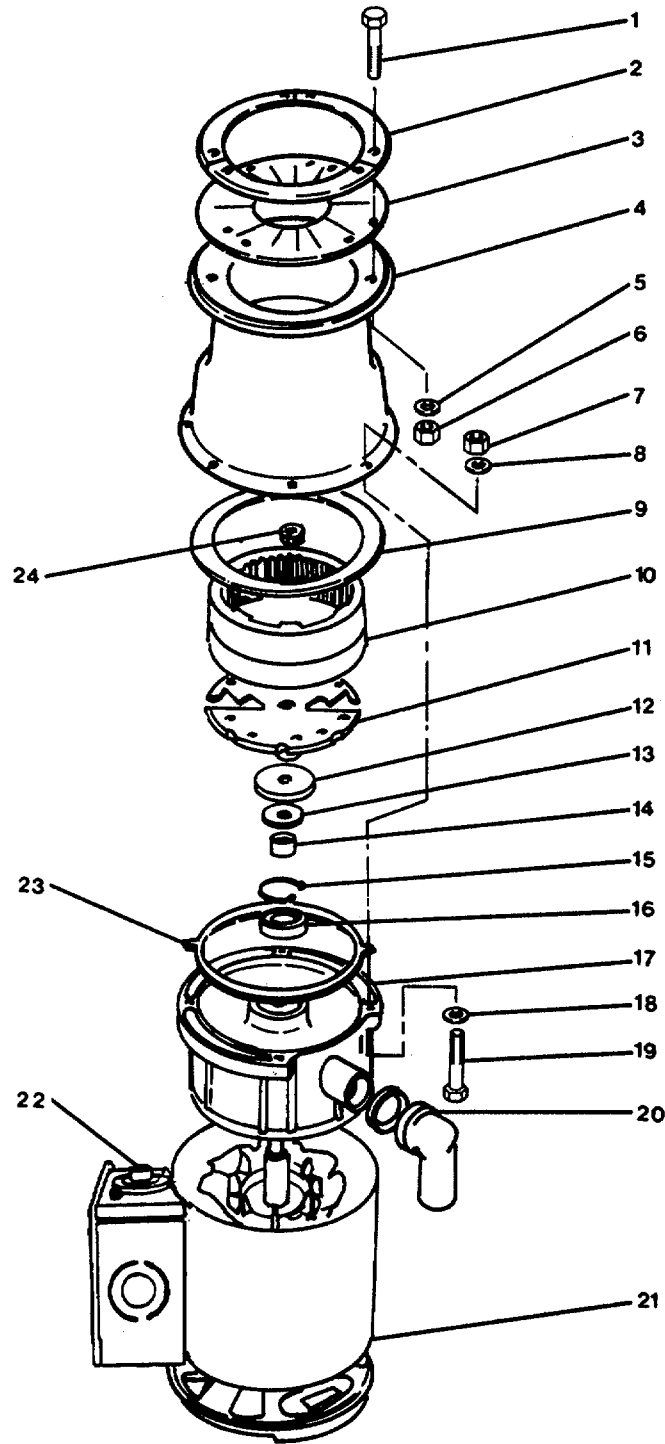

FIGURE 3-80. Repair Garbage Disposal.

1. Remove reset switch (22).

## REPAIR

Repair at this level of maintenance is by replacement of gasket (3), gasket (9), gasket (23), reset switch (22), and alternating current motor (21).

## ASSEMBLY

- a. Install reset switch (22).
- b. Remove tags and connect electrical leads.
- c. Install drain housing (17) and gasket (23).
- d. Install elbow (20) in drain housing.
- e. Install top bearing (16) and lock ring (15).
- f. Install spacer (14), water seal (13), secondary water shield (12), and rotor (11).
- g. Install lock nut (24).
- h. Install fan guard (10).
- i. Install gasket (9) and hopper (4).
- j. Install machine bolts (9), washer (18), lockwasher (8) and plain hexagon nut (7).
- k. Install gasket (3) and adapter segments (2).
- l. Install machine bolt (1), lockwasher (5), and plain hexagon nut (6).
- m. Refer to paragraph 2-74 .

---

**3-83. Repair Solid Waste Compactor.**

---

**This task covers:****a. Disassembly****b. Repair****c. Assembly**

---

INITIAL SETUP:Tools

Tool kit, general mechanic's,  
5180-00-699-5273  
Tool kit, electrician's,  
5180-00-391-1087

Equipment Condition

Solid waste compactor removed, para. 2-75 .

Materials/Parts

Rotary switch P/N 608824  
Toggle switch P/N 780398  
Push switch P/N 780421  
Solid state switch P/N 7801064  
Alternating current drive motor  
P/N 780378  
Sensitive switch P/N 777811  
Drawer safety push switch P/N 780420  
Power screw assembly P/N 777876  
Warning tags, Item 1, Appendix C

---

DISASSEMBLY

- a. Remove drawer (3, Figure 3-81).
- b. Remove machine screw (2) and remove control escutcheon (1).
- c. Tag and disconnect electrical leads.
- d. Remove screws (6) and nut plate (5).
- e. Remove top limit and directional sensitive switch (4).
- f. Remove drawer safety push switch (9).
- g. Remove lock ring and start-run rotary switch (7).
- h. Remove drawer tilt push switch (8).
- i. Remove toggle switch (10).
- j. Remove machine screw (11, Figure 3-82) and motor cover plate (12).
- k. Remove machine screw (30) motor cover (29).

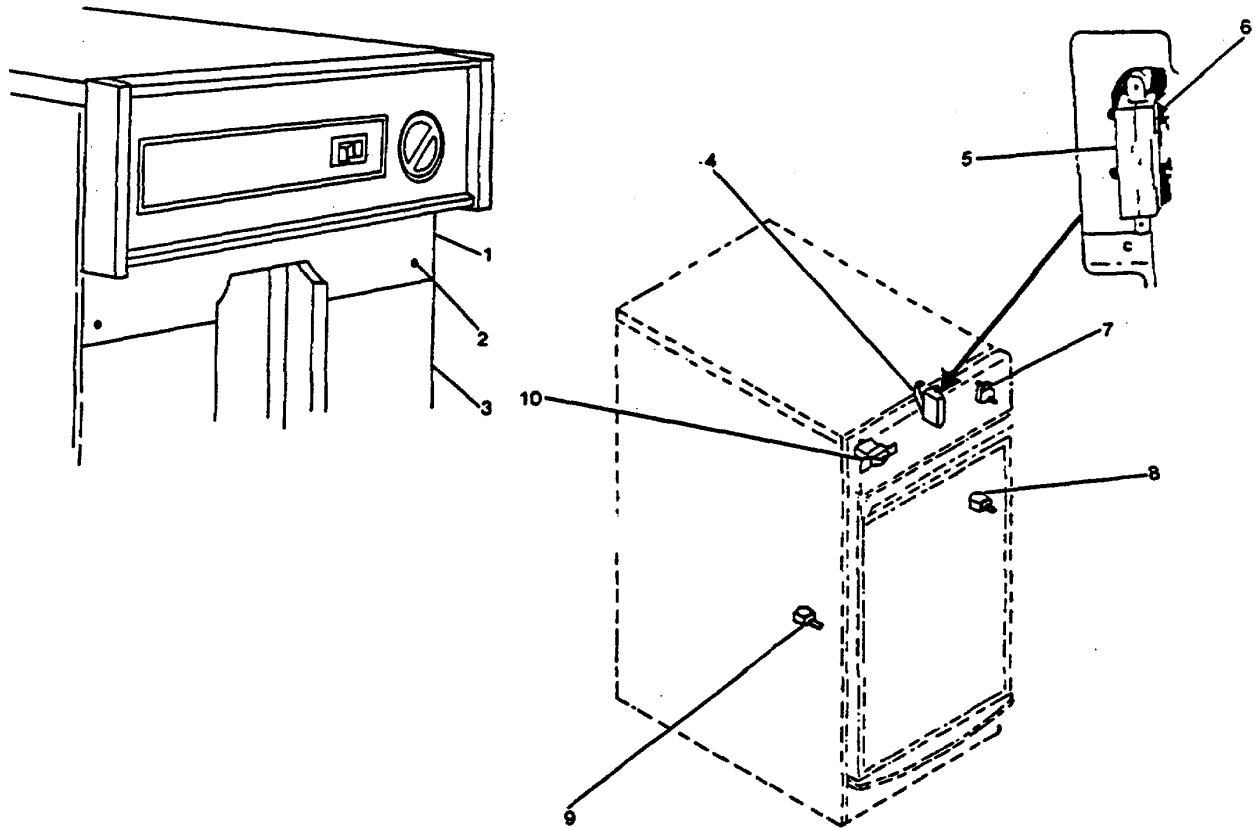

FIGURE 3-81. Compactor Switches.

- l. Remove screw (28) and solid state switch (27).
- m. Remove machine screw (14) and bottom pan (15).
- n. Turn driven gear (18) until ram (31) comes off of power screw assembly (33).
- o. Remove machine screw (32) and power screw assembly.
- p. Remove Clip ring (16), driven gear (18), thrust washer (19), and wave washer (20).
- q. Loosen machine bolt (25) and slide drive motor (26) forward.
- r. Remove drive Chain (17).
- s. Remove locknut (23) and remove drive motor from mount plate (24).

- t. Remove slotted spring pin (21) and drive gear (22) from motor.

## REPAIR

Repair at this level of maintenance is by replacement of: start-run rotary switch (7, Figure 3-81), toggle switch (10), drawer tilt push switch (8), drawer safety push switch (9), top limit and directional sensitive switch (4), solid state switch (27, Figure 3-82), alternating current motor (26), power screw assembly (33).

## ASSEMBLY

- a. Install drive gear (22) and slotted spring pin (21) on alternating current motor (26).
- b. Install drive motor on mount plate (24) and attach with locknut (23).
- c. Install drive chain (17).
- d. Slide drive motor (26) back and tighten machine bolt (25).
- e. Install wave washer (20), thrust washer (19), driven gear (18) and clip ring (16).
- f. Install power screw assembly (33) and attach with machine screw (32).
- g. Turn driven gear (18) until power screw assembly engages ram (31).
- h. Install bottom pan (15) and attach with machine screw (14).
- i. Install solid state switch (27) and attach with machine screw (28).
- j. Install motor cover (29) and attach with machine screw (30).
- k. Install motor cover plate (12) and attach with machine screw (11).
- l. Install toggle switch (10, Figure 3-81).
- m. Install drawer tilt push switch (8).
- n. Install start-run rotary switch (7) and lock ring.
- o. Install drawer safety push switch (9).
- p. Install top limit and directional sensitive switch (4).
- q. Install nut plate (5) and screws (6).
- r. Remove tags and connect electrical leads.
- s. Install control escutcheon (1) and attach with machine screw (2).
- t. Insert and close drawer (3).



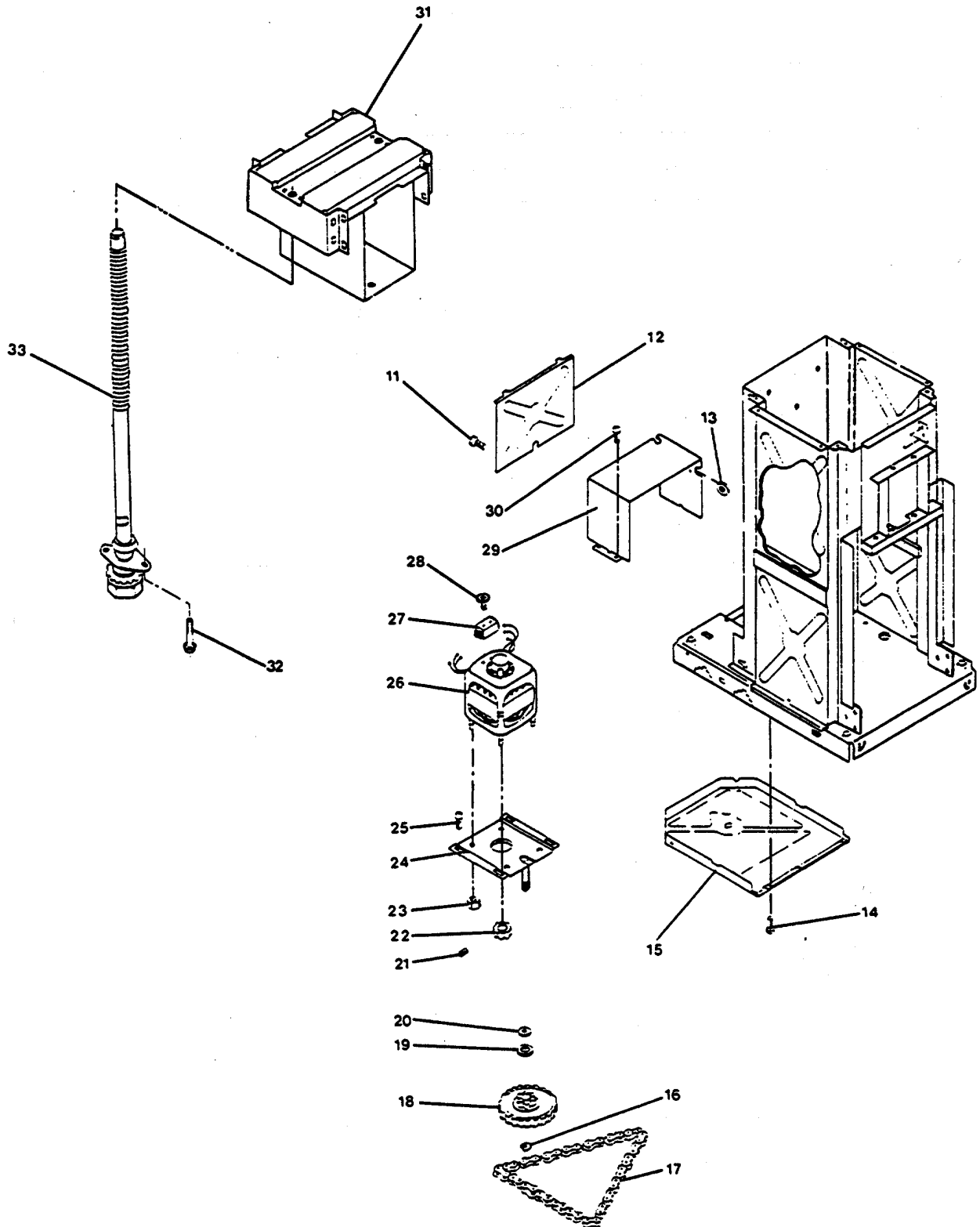

FIGURE 3-82. *Repair Solid Waste Compactor.*

---

**3-84. Repair R-30 Mechanical Refrigerator. (Figure 3-83)**

---

**This task covers:****a. Disassembly****b. Repair****c. Assembly**

---

INITIAL SETUP:ToolsTool kit, general mechanic's,  
5180-00-699-5273Tool kit, electrician's,  
5180-00-391-1087Equipment Condition

Refrigerator removed, para. 2-76 .

Materials/PartsRefrigerator  
P/N R30-2M-S

---

DISASSEMBLY

- a. Remove thermometer (1).
- b. Remove light switch (11).
- c. Remove latch assembly (2).
- d. Remove access door hinge (3) and access door.
- e. Remove pilaster clip (5).
- f. Remove shelf (4).
- g. Remove pilaster (6).
- h. Remove lamp shield (9).
- i. Remove lamp socket (10).
- j. Remove gasket (12).
- k. Remove condensation evaporator (8) from condenser unit (7).
- l. Remove condensate heater (13).

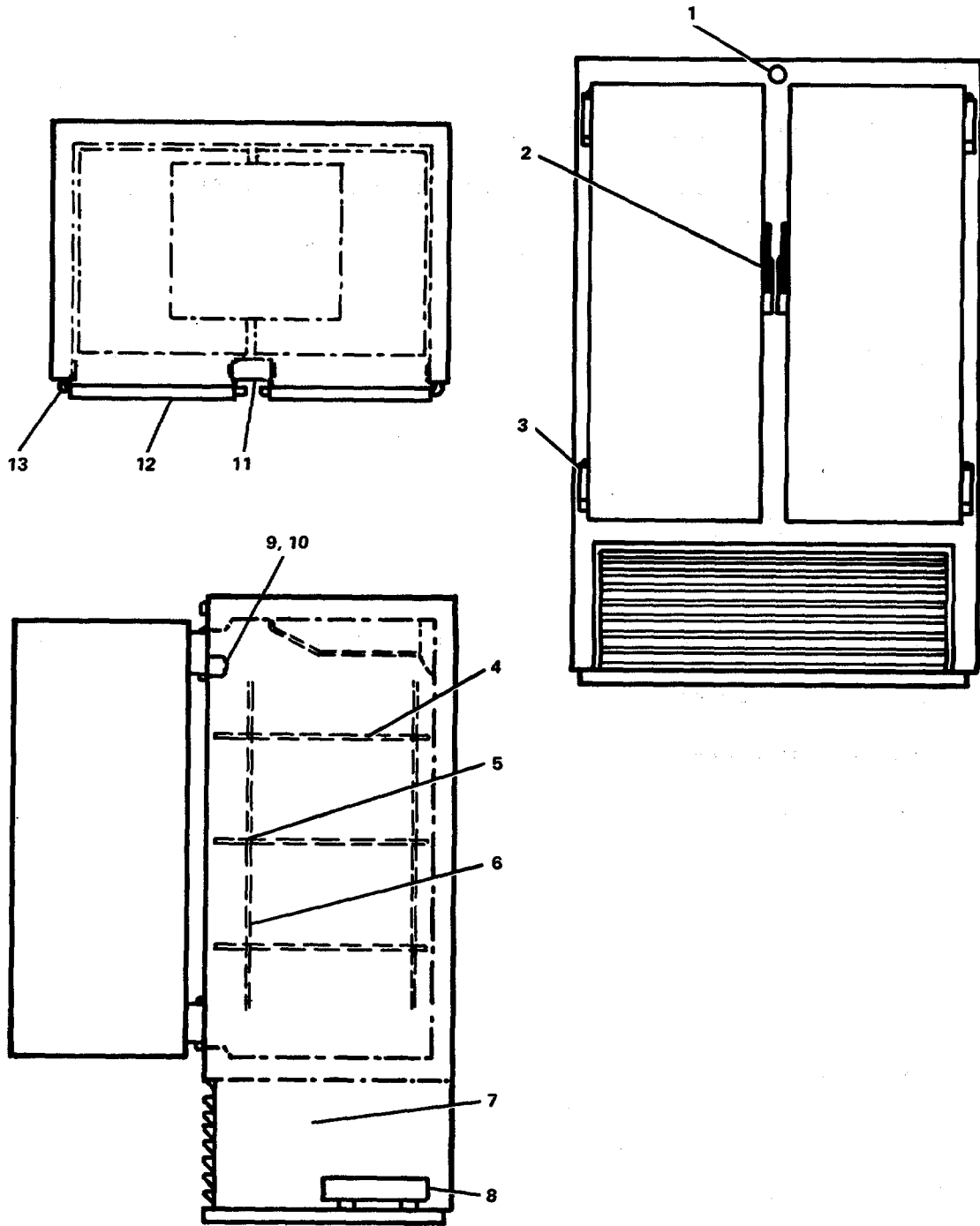

FIGURE 3-83. *Repair R-30 Refrigerator.*

REPAIR

Repair at this level of maintenance is by replacement of worn or defective parts.

ASSEMBLY

- a. Install condensate heater (13).
- b. Install condensation evaporator (8) in condenser unit (7).
- c. Install gasket (12).
- d. Install light switch (11).
- e. Install lamp socket (10).
- f. Install lamp shield (9).
- g. Install pilaster (6).
- h. Install shelf (4).
- i. Install pilaster clip (5).
- j. Install access door hinge (3) and access door.
- k. Install latch assembly (2).
- l. Install thermometer (1).
- m. Refer to paragraph 2-76 .

---

**3-85. Repair R-30 Mechanical Refrigerator - Refrigeration Condenser.**

---

This task covers:

a. Disassembly

b. Repair

c. Assembly

---

INITIAL SETUP:

Tools

Tool kit, general mechanic's,  
5180-00-699-5273  
Tool kit, electrician's,  
5180-00-391-1087

Equipment Condition

Refrigerator removed, 2-76 .  
Condenser unit removed, para. 2-77 .

Materials/Parts

Refrigerator  
P/N AE4440AC

---

DISASSEMBLY

- a. Refer to paragraph 3-77 .

REPAIR

Repair at this level of maintenance is by replacement of worn or defective parts.

ASSEMBLY

- a. Refer to paragraph 3-77 .

---

**3-86. Repair R-30 Mechanical Refrigerator - Refrigeration Evaporator Coil. (Figure 3-82).**

---

This task covers:

**a. Disassembly**

**b. Repair**

**c. Assembly**

---

INITIAL SETUP:

Tools

Tool kit, general mechanic's,  
5180-00-699-5273  
Tool kit, electrician's,  
5180-00-391-1087

Equipment Condition

Refrigerator removed, 2-76 .  
Evaporator coil unit removed, para. 2-78 .

Materials/Parts

Refrigerator evaporator coil  
P/N D20494

---

DISASSEMBLY

- a. Refer to paragraph 3-78 .

REPAIR

Repair at this level of maintenance is by replacement of worn or defective parts.

ASSEMBLY

- a. Refer to paragraph 3-78 .

---

**3-87. Repair F-30 Mechanical Food Freezer Refrigerator. (Figure 3-80)**

---

This task covers:

a. Disassembly

b. Repair

c. Assembly

---

INITIAL SETUP:

Tools

Tool kit, general mechanic's,  
5180-00-699-5273

Tool kit, electrician's,  
5180-00-391-1087

Equipment Condition

Freezer removed, 2-79 .

Materials/Parts

Mechanical freezer  
P/N F30-2M-ADS

---

DISASSEMBLY

- a. Refer to paragraph 3-84 .

REPAIR

Repair at this level of maintenance is by replacement of worn or defective parts.

ASSEMBLY

- a. Refer to paragraph 3-84 .

---

**3-88. Repair F-30 Mechanical Food Freezer - Refrigerator Condenser.**

---

This task covers:

a. Disassembly

b. Repair

c. Assembly

---

INITIAL SETUP:

Tools

Tool kit, general mechanic's,  
5180-00-699-5273

Equipment Condition

Freezer condenser removed, para. 2-80 .

Materials/Parts

Mechanical freezer  
P/N AJ2425AC

---

DISASSEMBLY

- a. Refer to paragraph 3-80 .

REPAIR

Repair at this level of maintenance is by replacement of worn or defective parts.

ASSEMBLY

- a. Refer to paragraph 3-80 .



---

**3-89. Repair F-30 Mechanical Food Freezer - Refrigeration Evaporator Coil.**

---

**This task covers:**

**a. Disassembly**

**b. Repair**

**c. Assembly**

---

INITIAL SETUP:

Tools

Tool kit, general mechanic's,  
5180-00-699-5273  
Tool kit, electrician's,  
5180-00-391-1087

Equipment Condition

Refrigeration evaporator coil removed, para. 2-70 .

Materials/Parts

Mechanical freezer  
P/N D20494

---

DISASSEMBLY

- a. Refer to paragraph 3-81 .

REPAIR

Repair at this level of maintenance is by replacement of worn or defective parts.

ASSEMBLY

- a. Refer to paragraph 3-81 .

**3-90. Repair Dishwasher. (Figure 3-84)****This task covers:****a. Disassembly****b. Repair****c. Assembly**INITIAL SETUP:Tools

Tool kit, general mechanic's,  
5180-00-699-5273  
Tool kit, electrician's,  
5180-00-391-1087

Equipment Condition

Freezer removed, para. 2-82 .

Materials/Parts

Dishwasher P/N UC-1  
Solenoid valve P/N W-0-70200  
Thermometer gauge P/N W-0-70155  
Pressure gauge P/N W-0-70156  
Vacuum breaker P/N W-0-70201  
Hose P/N W-0-70346  
Hose P/N W-0-70347  
Fill/start switch P/N W-0-70154  
Heat on/off switch P/N W-0-70153  
Limit switch P/N W-0-70152  
Electrical heating element  
P/N W-0-70094  
Heat contactor P/N W-1-07209  
Transformer P/N W-1-07957  
Relay P/N W-0-14246  
Cycle timer P/N W-0-70189  
Thermostat P/N W-1-07768  
Motor contactor P/N W-0-70192  
Motor overload P/N M-0-71603  
Fast acting fuse P/N W-0-70434  
Rinse arm P/N W-1-70086  
Rinse arm nozzle P/N W-0-70087  
Wash arm P/N W-2-70083  
Wash arm nozzle P/N W-1-70084  
Hub assembly P/N W-2-70082  
Gasket P/N W-1-70067

DISASSEMBLY

- a. Remove top cover (1).
- b. Remove rear panel (11).

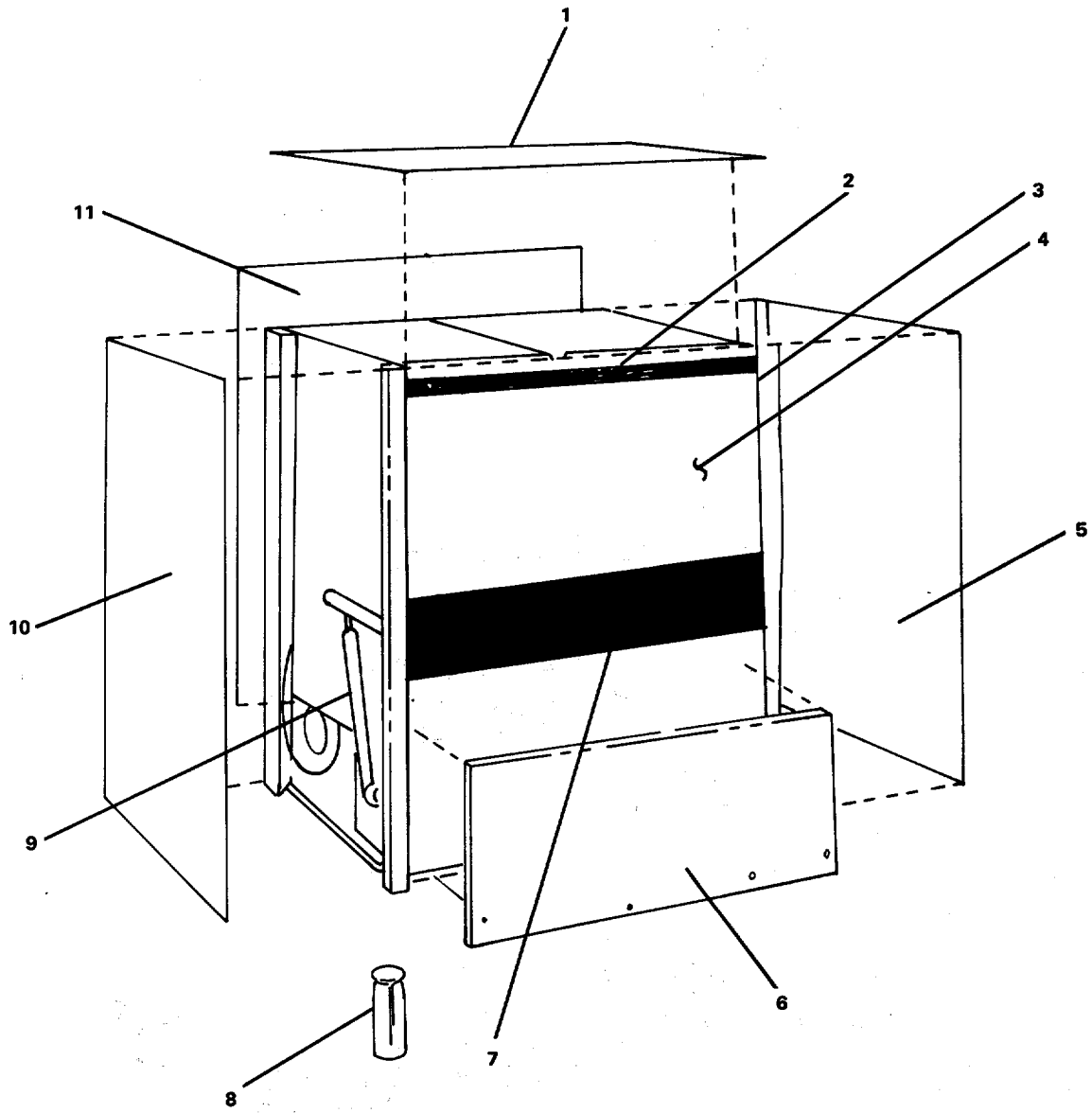

FIGURE 3-84. *Dishwasher (Sheet 1 of 4).*

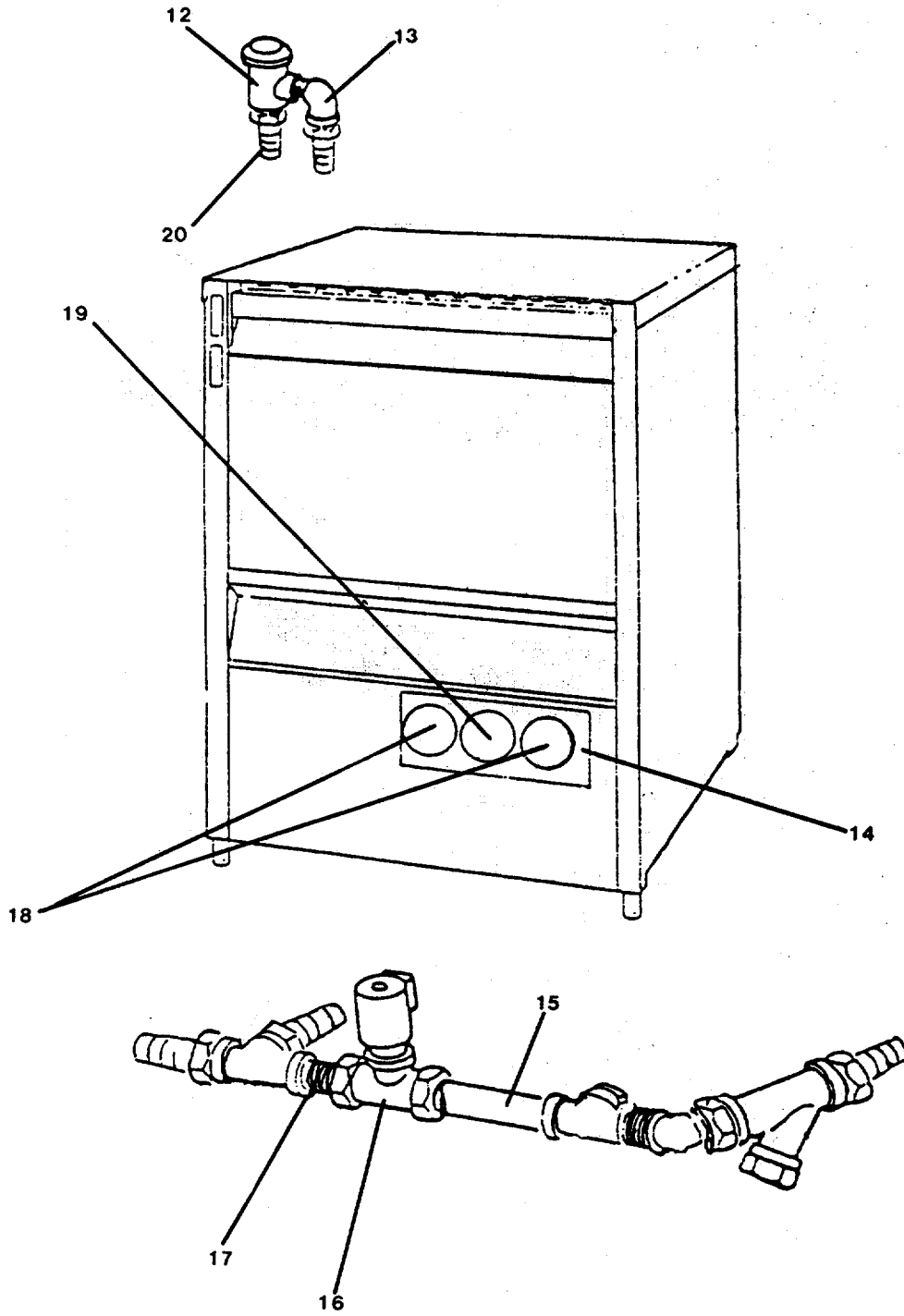

FIGURE 3-84. *Dishwasher (Sheet 2 of 4).*

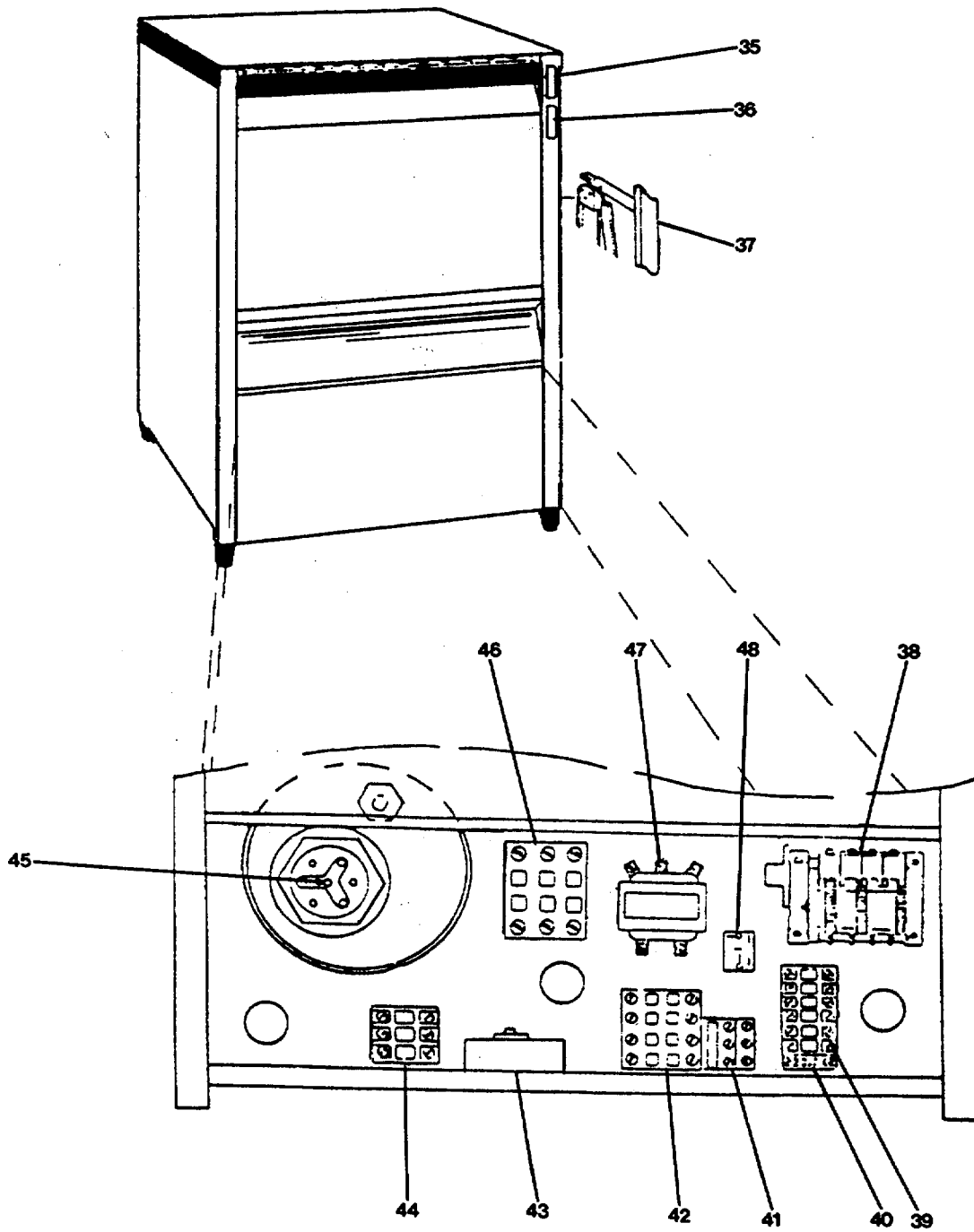

FIGURE 3-84. Dishwasher (Sheet 3 of 4).

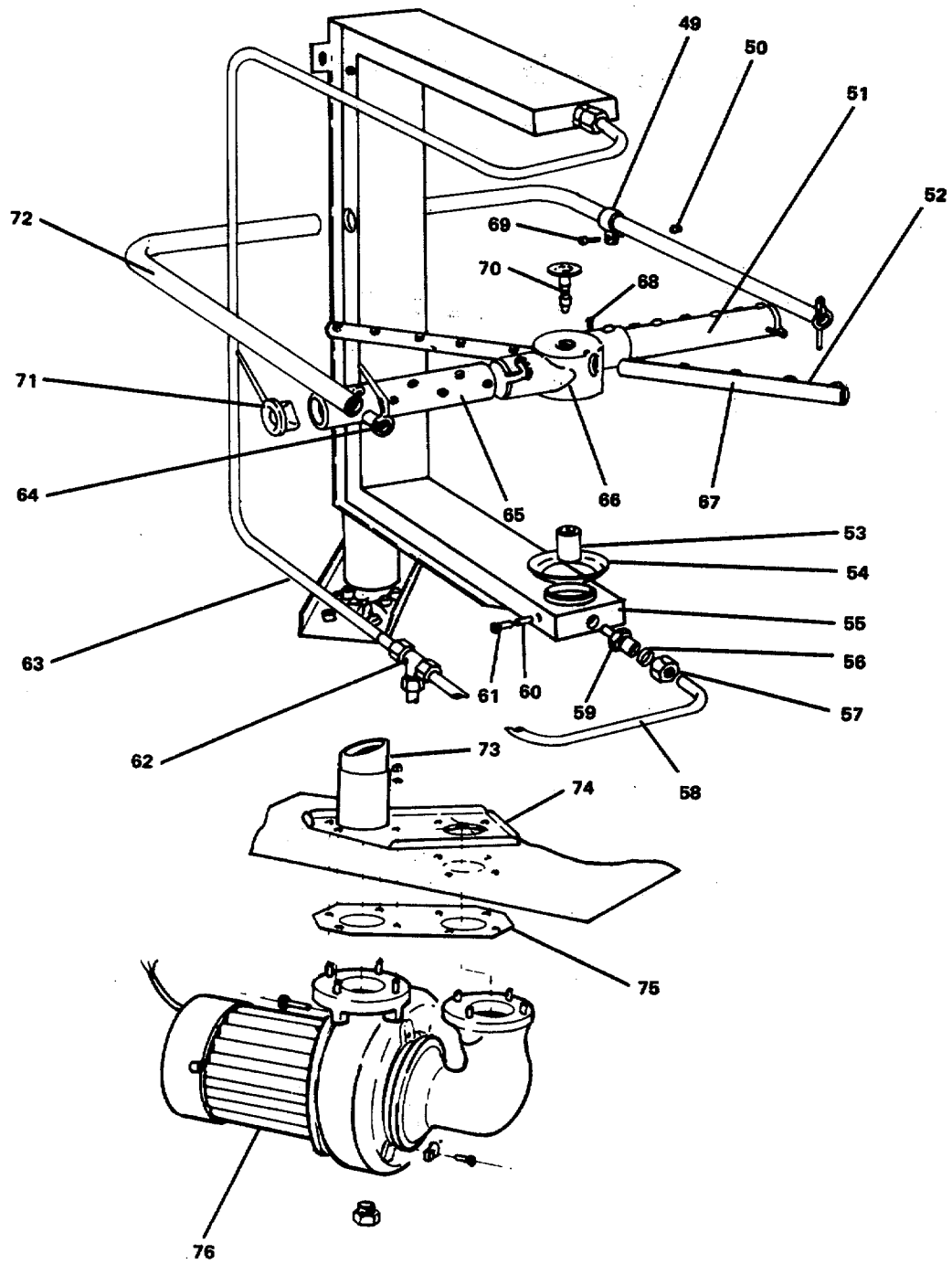

FIGURE 3-84. *Dishwasher (Sheet 4 of 4).*

- c. Remove right hand panel (5).
- d. Remove front panel (6).
- e. Remove left hand panel (10).
- f. Remove door spring (9).
- g. Remove handle (2).
- h. Remove hinge cover panel (7).
- i. Remove bracket (3).
- j. Remove frame with door (4).
- k. Remove adjustable leg (8).
- l. Remove hose nipples (25 and 26, Sheet 2), from tee (24). Remove tee.
- m. Remove close nipple (23) from solenoid valve (22).
- n. Loosen nipple (27) from solenoid valve (22). Remove solenoid valve (22).
- o. Remove tee (21) from close nipple (20).
- p. Remove close nipple from elbow (19).
- q. Remove hose nipple (17) from strainer hose (18). Remove strainer hose.
- r. Remove reducing bushing (28). Remove elbow (19).
- s. Remove thermometer gauges (29, 30).
- t. Remove pressure gauge (32).
- u. Remove bracket (16).
- v. Remove pump inlet strainer (31).
- w. Remove hose nipple (33) from elbow (13). Remove elbow.
- x. Remove hose nipple (34) from vacuum breaker (12). Remove vacuum breaker.
- y. Remove stand pipe (14).
- z. Remove outlet drain assembly (15).
- aa. Remove fill/start switch (35, Sheet 3).
- ab. Remove heat on/off switch (36).
- ac. Remove limit switch (37).

- ad. Remove electrical heating element (45).
- ae. Remove heat contactor (46).
- af. Remove transformer (47).
- ag. Remove relay (48).
- ah. Remove cycle timer (38).
- ai. Remove power terminal (44).
- aj. Remove thermostat (43).
- ak. Remove motor contactor (42).
- al. Remove motor overload (41).
- am. Remove fast acting fuse (40).
- an. Remove control terminal (39).
- ao. Remove bolt (69, Sheet 4), nut (50), and clip (49).
- ap. Remove adjustment screw (68).
- aq. Remove spray arm knob (70) and hub assembly (66).
- ar. Remove rinse arm (67) and rinse arm nozzle (52).
- as. Remove fixed spray arm (72) and end cap (64).
- at. Remove wash arm (51) and wash arm nozzle (65) and end cap (71).
- au. Remove compression nut (57), compression ring (56), and rinse block connector (59).
- av. Remove lower rinse manifold (58) after loosening compression nut on compression tee (62).
- aw. Remove upper rinse manifold (63) and compression tee (62) from wash manifold (55).
- ax. Remove hexagon nut (61) and spacer (60).
- ay. Remove rinse block (53) and cup washer (54).
- az. Remove wash manifold (55).
- ba. Remove hose (73) from hose nozzle and pump inlet plate (74).
- bb. Remove pump and motor assembly (76) and gasket (75).



**REPAIR**

Repair at this level of maintenance is by replacement of solenoid valve (22, Sheet 2), thermometer gauges (29, 30), pressure gauge (32), vacuum breaker (12), fill/start switch (35, Sheet 3), heat on/off switch (36), limit switch (37), electrical heating element (45), heat contractor (46), transformer (47), relay (48), cycle timer (38), thermostat (43), motor contactor (42), motor overload (41), fast acting fuse (40), rinse arm (67, Sheet 4), rinse arm nozzle (52), wash arm (51), wash arm nozzle (65), hub assembly (66), hose (73, Sheet 2), gasket (75), pump and motor assembly (76).

**ASSEMBLY**

- a. Install gasket (75) and pump and motor assembly (76).
- b. Install hose (73) into hose nozzle on pump inlet plate (74).
- c. Install wash manifold (55).
- d. Install cup washer (54) and rinse block (53).
- e. Install spacer (60) and hexagon nut (61).
- f. Install end cap (64) and fixed spray arm (72).
- g. Install compression tee (62) and upper rinse manifold (63) on wash manifold (55).
- h. Install lower rinse manifold (58) on compression tee (62).
- i. Install rinse block connector (59), compression ring (56), and compression nut (57).
- j. Install end cap (71) and washer arm nozzle (65).
- k. Install rinse arm nozzle (52) and rinse arm (67).
- l. Install hub assembly (66) and spray arm knob (70).
- m. Install adjustment screw (68).
- n. Install clip (49), nut (50), and bolt (69).
- o. Install control terminal (39).
- p. Install fast acting fuse (40).
- q. Install motor overload (41).
- r. Install motor contactor (42).
- s. Install thermostat (43).

- t. Install power terminal (44).
- u. Install cycle timer (38).
- v. Install relay (48).
- w. Install transformer (47).
- x. Install heat contactor (46).
- y. Install electrical heating element (45).
- z. Install limit switch (37).
- aa. Install on/off switch (36).
- ab. Install fill/start switch (35).
- ac. Install outlet drain assemble (15, Sheet 2).
- ad. Install stand pipe (14).
- ae. Install vacuum breaker (12) and nipple (34).
- af. Install 1 elbow (13) and hose nipple (33).
- ag. Install pump inlet strainer (31).
- ah. Install bracket (16).
- ai. Install pressure gauge (32).
- aj. Install thermometer gauges (29, 30).
- ak. Install elbow (19) and reducing bushing (28).
- al. Install hose strainer (18) and hose nipple (17).
- am. Install close nipple (20) and tee (21).
- an. Install solenoid valve (22) and nipple (27) on tee.
- ao. Install close nipple (23).
- ap. Install tee (24) and hose nipples (25, 26).
- aq. Install adjustable leg (8, Sheet 1).
- ar. Install frame with door (4).
- as. Install bracket (3).
- at. Install hinge cover panel (7).

- au. Install handle (2).
- av. Install door spring (9).
- aw. Install left hand panel (10).
- ax. Install front panel (6).
- ay. Install right hand panel (5).
- az. Install rear panel (11).
- ba. Install top cover (1).
- bb. Refer to paragraphs 3-91 and 2-82 .

---

**3-91. Repair Dishwasher Pump and Motor Assembly (Figure 3- 85)**

---

**This task covers:****a. Disassembly****b. Repair****c. Assembly**

---

**INITIAL SETUP:**Tools

Tool kit, general mechanic's,  
5180-00-699-5273

Equipment Condition

Dishwasher removed, para. 2-82 .  
Dishwasher disassembled, para. 3-90 .

Materials/Parts

Pump and motor assembly  
P/N W-4-70069

Preformed packing P/N W-0-70108  
Preformed packing P/N W-0-70111  
Preformed packing P/N W-0-70102  
Encased plain seal P/N W-O-70101  
Motor P/N W-O-70096

**DISASSEMBLY**

- a. Remove hexagon bolt (2).
- b. Remove motor (21) and cord (1) from pump housing (18).
- c. Remove spacer (20).
- d. Remove hexagon bolt (11) and housing clamp (12).
- e. Remove suction pipe (10) and preformed packing (8).
- f. Remove hexagon bolt (13) and preformed packing (7).
- g. Remove retainer (14), preformed packing (6), and impeller (15).
- h. Remove bushing (16) and preformed packing (5).
- i. Remove encased plain seal (4).
- j. Remove bellows seal (17).
- k. Remove drain plug (19).
- l. Remove studs (3, 9).

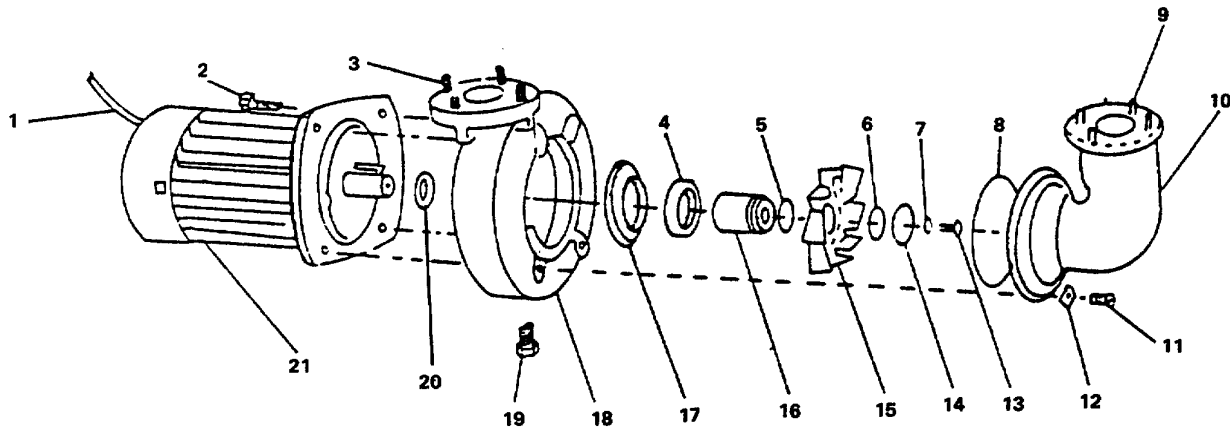

FIGURE 3-85. *Pump and Motor Assembly.*

## REPAIR

Repair at this level of maintenance is by replacement of preformed packings (5, 6, 7, 8), encased plain seal (4), and motor (21).

## ASSEMBLY

- a. Install studs (3, 9).
- b. Install drain plug (19).
- c. Install preformed packing (5) and bushing (16) on impeller (15).
- d. Install preformed packing (6) and retainer (14) on impeller (15) with preformed packing (7) and hexagon bolt (13).
- e. Install encased plain seal (4) and bellows seal (17) over bushing (16).
- f. Install spacer (20) on motor (21).
- g. Install assembled impeller unit on motor shaft.
- h. Install pump housing (18) on motor (21) and cord (1) with hexagon bolt (2).
- i. Install preformed packing (8) and suction pipe (10).

- j. Install housing clamp (12) and hexagon bolt (11).
- k. Install spacer (20).
- l. Replace dishwasher; refer to paragraph 2-82 .
- m. Assemble dishwasher; refer to paragraph 3-90 .

---

**3-92. Repair Washer Machine. (Figure 3-86)**

---

**This task covers:****a. Disassembly****b. Repair****c. Assembly**

---

**INITIAL SETUP:**ToolsTool kit, general mechanic's,  
5180-00-699-5273Tool kit, electrician's,  
5180-00-391-1087

Tool kit, No. 357P3

Equipment Condition

Washer machine removed, para. 2-83 .

Materials/Parts

Rotary switch P/N 27761

Rotary switch P/N 27762

Unbalanced load indicator light  
P/N 27769In use indicator light  
P/N 29543Rinse indicator light  
P/N 29544Spin indicator light  
P/N 29545

Stop timer P/N 28716

Warning tags, Item 1, Appendix C

---

**DISASSEMBLY**

- a. Remove machine screw (16), hexagon head capscrews (13), and washers (12, 15).
- b. Remove control hood (6) and gasket (20).
- c. Remove hexagon head capscrew (18) and pressure switch (19).
- d. Remove bracket (17).
- e. Remove hexagon head capscrews (8, 9) and panel (7).
- f. Remove machine screw (1) and speed nut (5).
- g. Tag and disconnect electrical leads.
- h. Remove control panel (25) and control panel support (26).
- i. Remove spin indicator light (27).

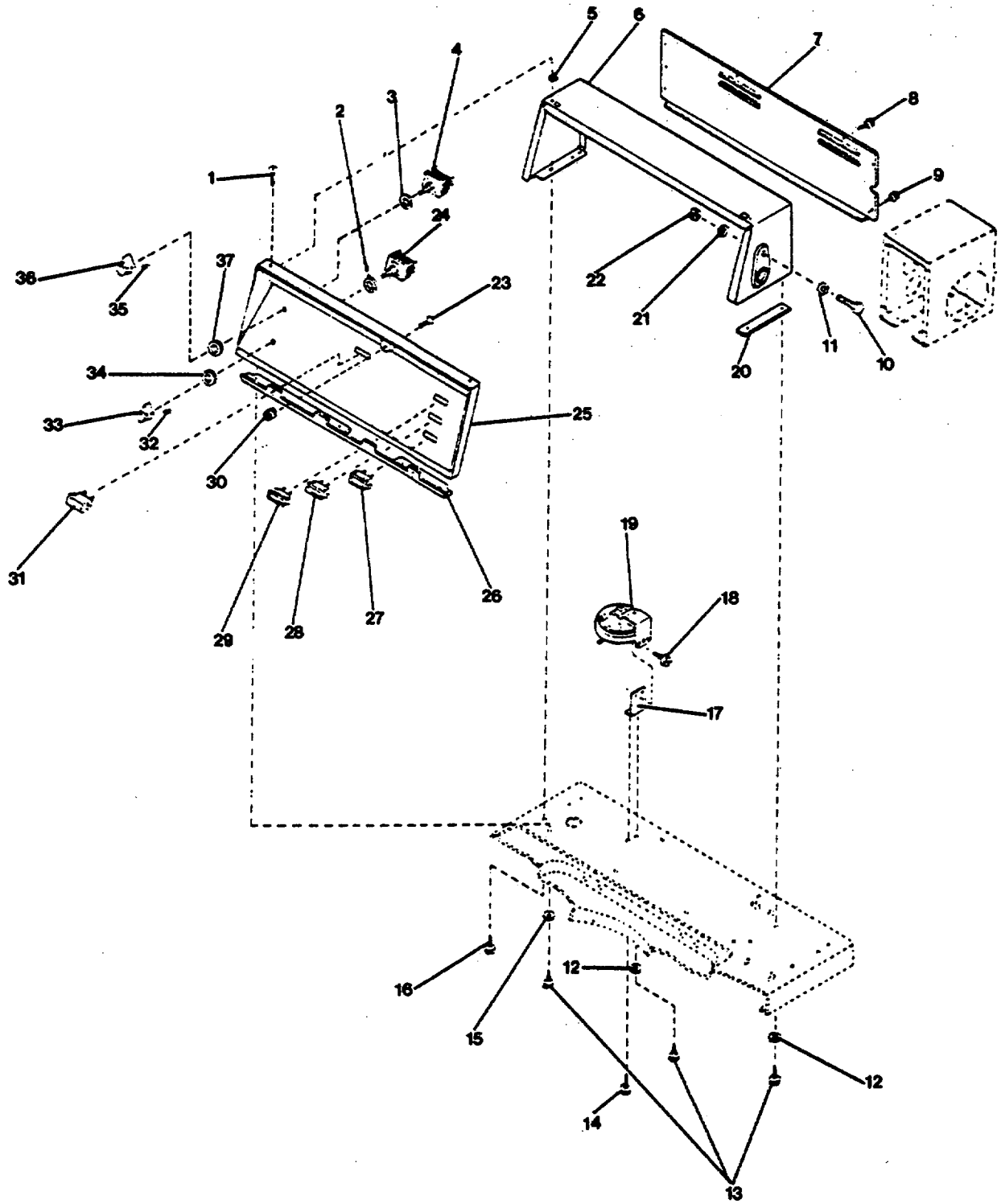

FIGURE 3-86. Washer Machine (Sheet 1 of 5).



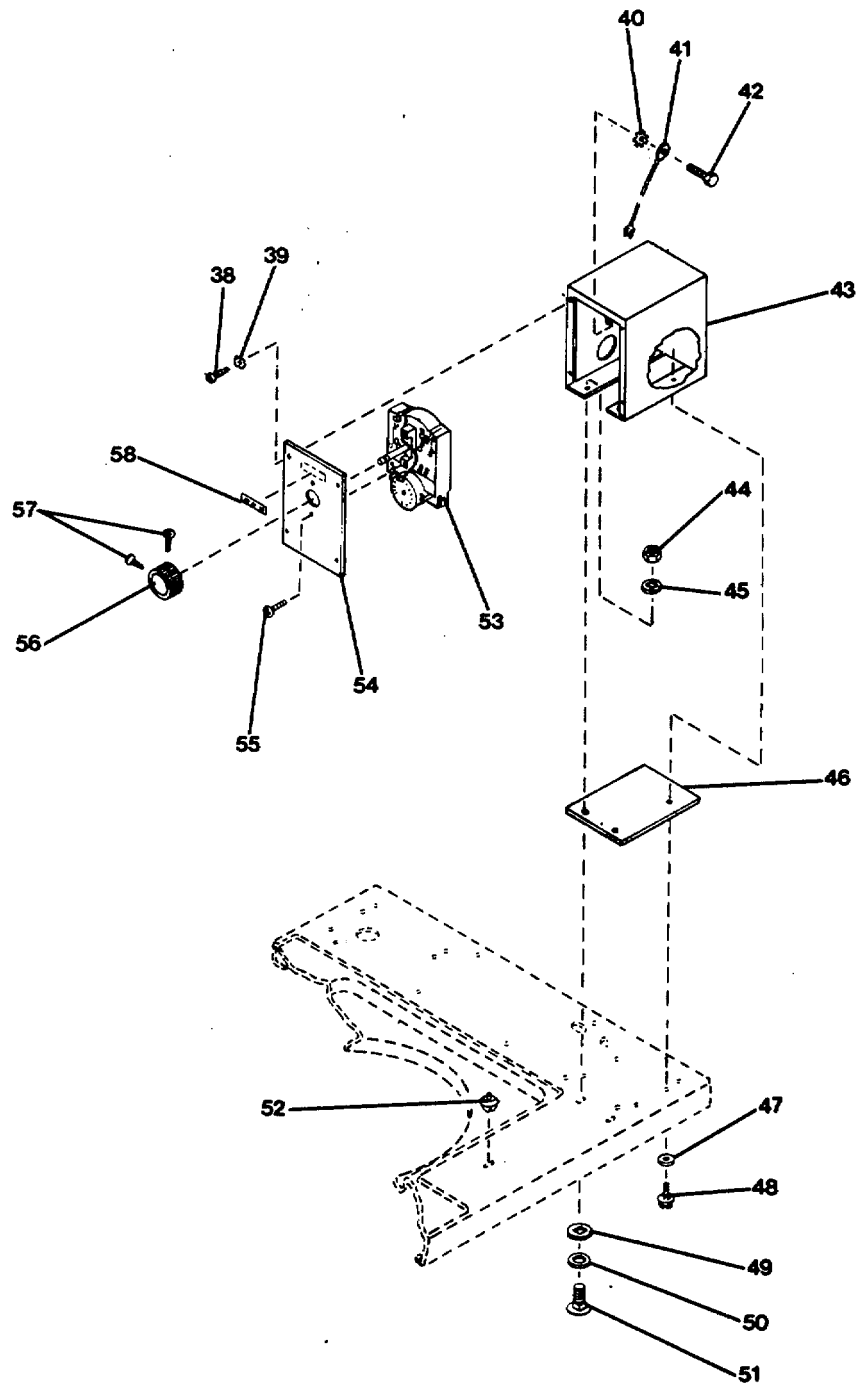

FIGURE 3-86. *Washer Machine (Sheet 2 of 5).*

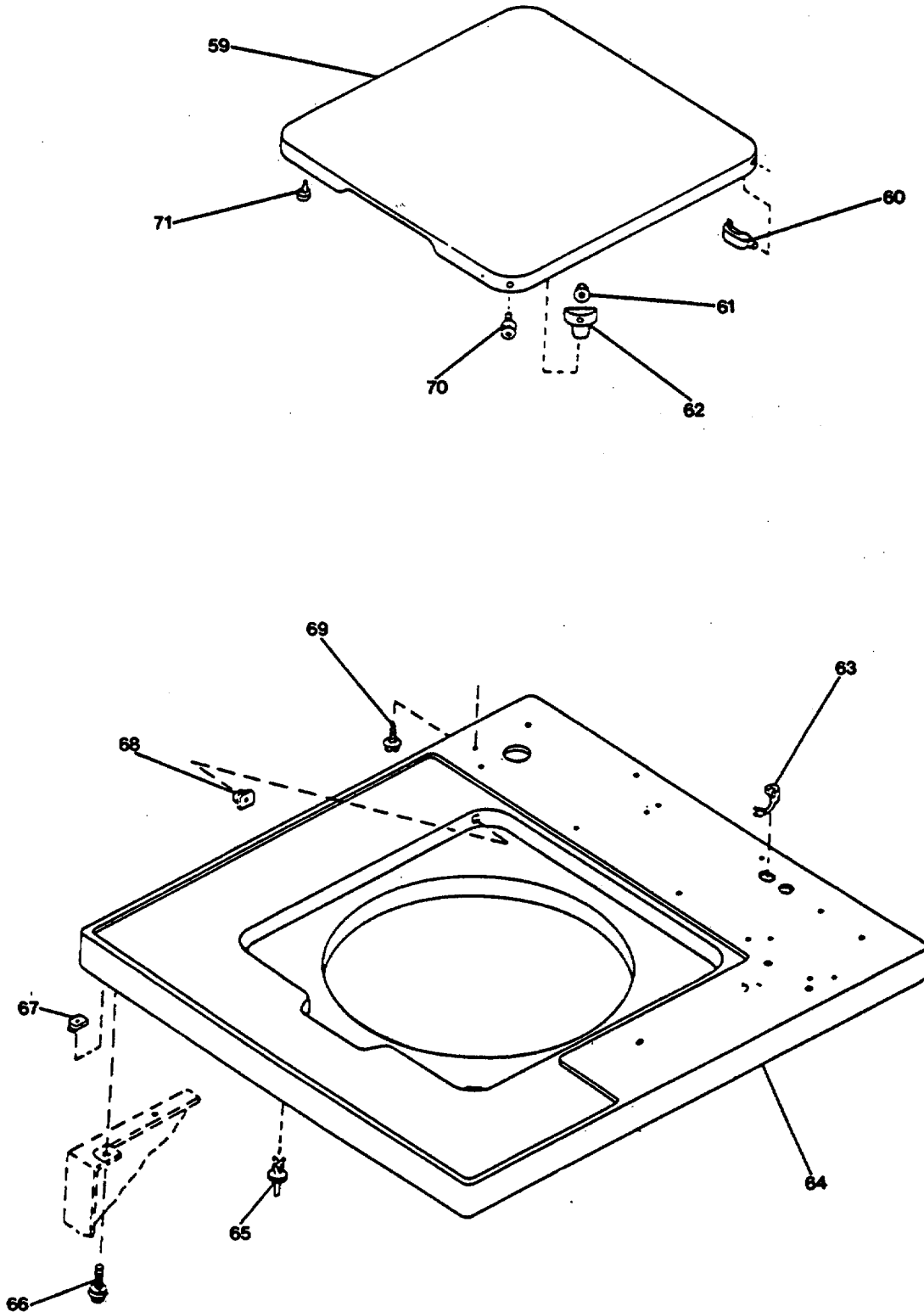

FIGURE 3-86. *Washer Machine (Sheet 3 of 5).*

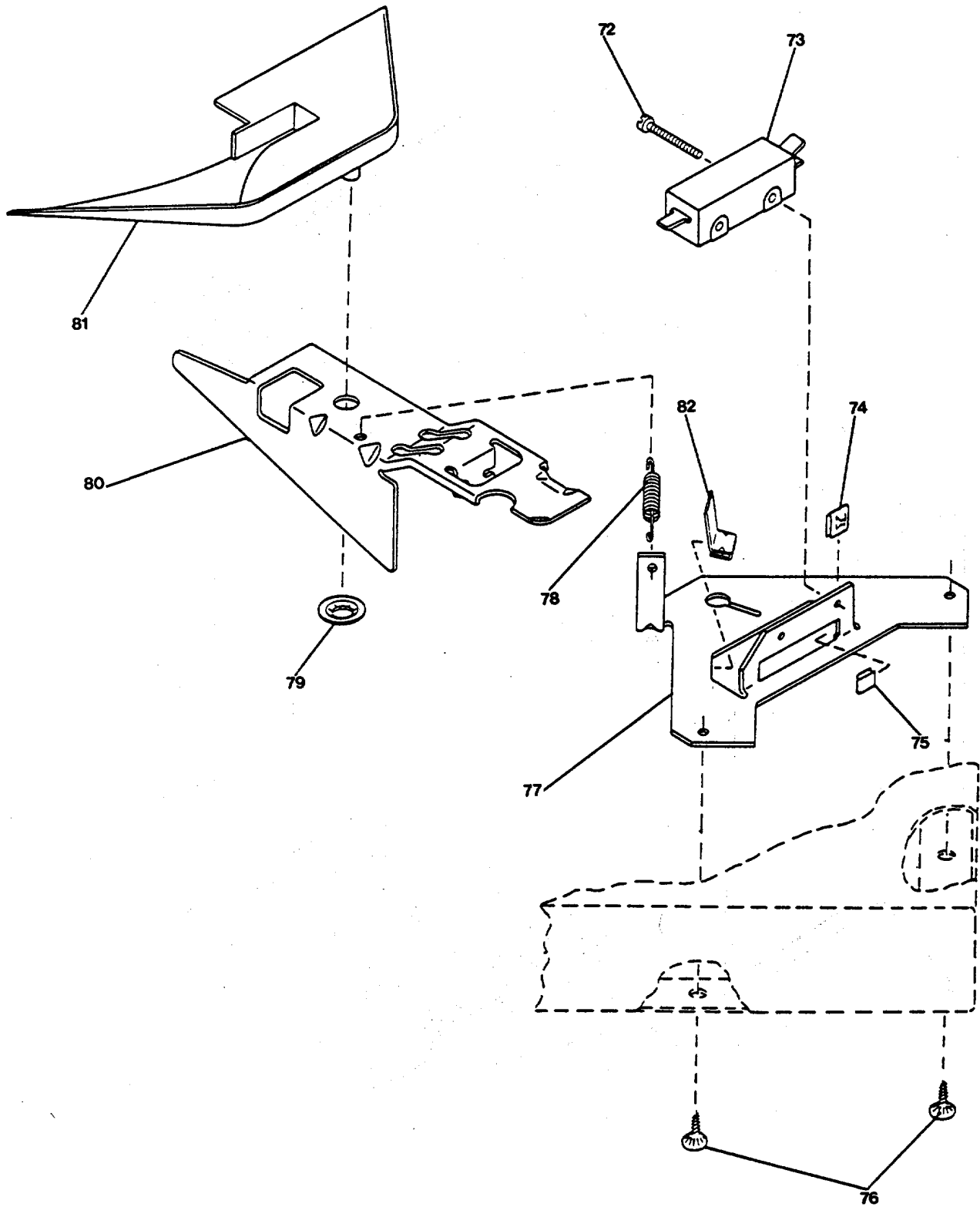

FIGURE 3-86. *Washer Machine (Sheet 4 of 5).*

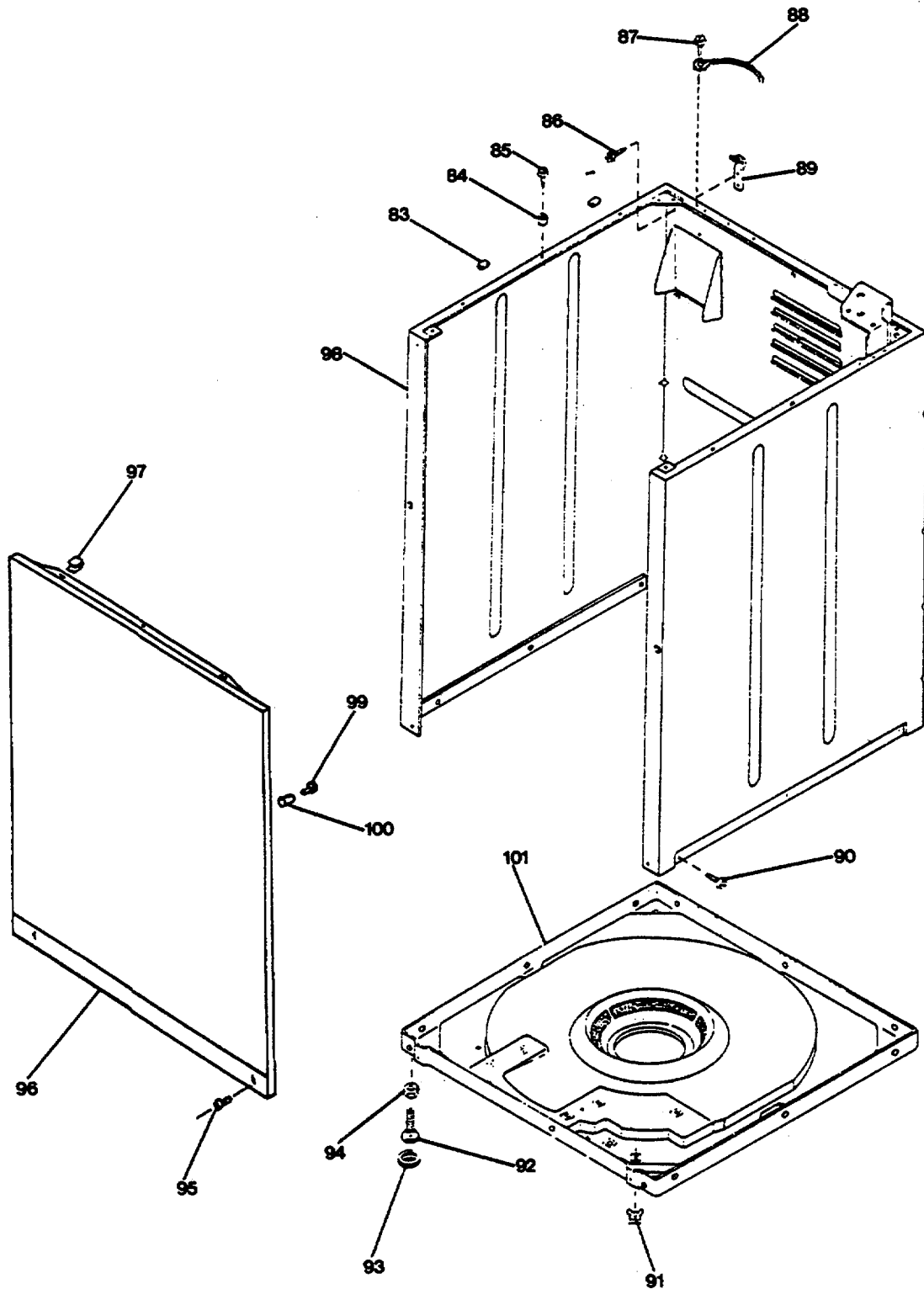

FIGURE 3-86. Washer Machine (Sheet 5 of 5).

- j. Remove rinse indicator light (28).
- k. Remove in use indicator light (29).
- l. Remove unbalanced load indicator light (31).
- m. Remove hexagon head capscrew (23) and bumper (30)..
- n. Remove setscrew (32), knob (33), knurled nut (34), lockwasher (2), and rotary switch (24).
- o. Remove setscrew (35), knob (36), knurled nut (37), lockwasher (3), and rotary switch (4).
- p. Remove plain hexagon nut (44, Sheet 2), lockwasher (45), washer (49), flat washer (50) and carriage bolt (51).
- q. Remove hexagon head capscrew (48) and washer (47).
- r. Remove hexagon head capscrew (42), ground wire (41), and lockwasher (40).
- s. Remove timer case (43).
- t. Remove machine screws (57) and timer knob (56).
- u. Remove machine screw (38) and lockwasher (39).
- v. Remove machine screw (55), access plate (54), and stop timer (53).
- w. Remove rivet (52).
- x. Remove hexagon head capscrew (10, Sheet 1), lockwashers (11, 21), and plain hexagon nut (22).
- y. Remove assembled washer screw (66, Sheet 3) and speed nut (67).
- z. Remove support rivet (65).
- aa. Remove strain relief (63).
- ab. Remove machine screw (69).
- ac. Remove bushing (68).
- ad. Remove cabinet top (64).
- ae. Remove hinge (60) and loading door (59).
- af. Remove assembled washer screw (70), catch (62), and nylon nut (61).
- ag. Remove bumper (71).
- ah. Remove spring (78, Sheet 4).
- ai. Remove screws (76) and U-clip (82).

- aj. Remove bracket (75).
- ak. Remove machine screw (72) and sensitive switch (73).
- al. Remove U-clip (74).
- am. Remove bracket (77).
- an. Remove push nut (79), shield (81), and lever (80).
- ao. Remove machine screw (95, Sheet 5) and front panel (96).
- ap. Remove machine screw (99) and lug guide (100).
- aq. Remove hold-down clip (97).
- ar. Remove pad (83).
- as. Remove machine screw (85) and sleeve bushing (84).
- at. Remove hexagon head capscrew (86) and hinge (89).
- au. Remove hexagon head capscrew (87) and ground wire (88).
- av. Remove hexagon head capscrew (90) and cabinet (98).
- aw. Remove nut (91).
- ax. Remove pad (93), leveling leg (92), and lock nut (94) from base (101).

## REPAIR

Repair at this level of maintenance is by replacement of rotary switches (4 and 11, Sheet 1), unbalanced load indicator light (31), in use indicator light (29), rinse indicator light (28), spin indicator light (27), and stop timer (53, Sheet 2).

## ASSEMBLY

- a. Install locknut (94), leveling leg (92) and pad (93) on base (101).
- b. Install nut (91).
- c. Install cabinet (98) on base (101) with hexagon head capscrews (90).
- d. Install ground wire (88) and hexagon head capscrew (87).
- e. Install hinge (89) and hexagon head capscrew (86).
- f. Install sleeve bushing (84) and machine screw (85).
- g. Install pad (83).

- h. Install hold-down clip (97).
- i. Install lug guide (100) and machine screw (99).
- j. Install front panel (96) and machine screw (95).
- k. Install lever (80, Sheet 4), shield (81) and pushnut (79).
- l. Install bracket (77).
- m. Install U-clip (74).
- n. Install sensitive switch (73) and machine screw (72).
- o. Install bracket (75).
- p. Install U-clip (82) and screw (76).
- q. Install spring (78).
- r. Install bumper (71, sheet 3).
- s. Install assembled washer screw (70), catch (62), and nylon nut (61).
- t. Install loading door (59) and hinge (60).
- u. Install cabinet top (64).
- v. Install bushing (68).
- w. Install machine screw (69).
- x. Install strain relief (63).
- y. Install support rivet (65).
- z. Install speed nut (67) and assembled washer screw (66).
- aa. Install hexagon head capscrew (10, Sheet 1), lockwashers (11, 21), and plain hexagon nut (22).
- ab. Install rivet (52, Sheet 2).
- ac. Install stop timer (53), access plate (54), and machine screw (55).
- ad. Install lockwasher (39) and machine screw (38).
- ae. Install timer knob (56) and machine screws (57).
- af. Install timer case (43).
- ag. Install hexagon head capscrew (42) with ground wire (41), and lockwasher (40).
- ah. Install washer (47) and hexagon head capscrew (48).

- ai. Install carriage bolt (51), flat washer (50), washer (49), lockwasher (45), plain hexagon nut (44).
- aj. Install rotary switch (4, Sheet 1), lockwasher (3), knurled nut (37), knob (36), and setscrew (35).
- ak. Install rotary switch (24), lockwasher (2), knurled nut (34), knob (33), and setscrew (32).
- al. Install bumper (30) and hexagon head capscrew (23).
- am. Install unbalanced load indicator light (31).
- an. Install in use indicator light (29).
- ao. Install rinse indicator light (28).
- ap. Install spin indicator light (27).
- aq. Install control panel support (26) and control panel (25).
- ar. Remove tag and connect electrical leads.
- as. Install speed nut (5) and machine screw (1).
- at. Install panel (7) and hexagon head capscrews (8, 9).
- au. Install bracket (17).
- av. Install pressure switch (19) and hexagon head capscrew (18).
- aw. Install gasket (20) and control hood (6).
- ax. Install washers (12, 15), hexagon head capscrews (13), and machine screw (16).
- ay. Refer to paragraph 2-83 .



---

**3-93. Repair Washer Machine Water Mixing Valve Assembly. (Figure 3-87)**

---

**This task covers:**

**a. Disassembly**

**b. Repair**

**c. Assembly**

---

**INITIAL SETUP:****Tools**

Tool kit, general mechanic's,  
5180-00-699-5273

**Equipment Condition**

Washer machine removed, para. 2-83 .  
Water mixing valve assembly removed,  
para. 2-84 .

**Materials/Parts**

Water mixing valve P/N 27156

---

**DISASSEMBLY**

- a. Remove machine screw (2).
- b. Remove valve body (8) from mounting bracket (3).
- c. Remove armature valve guide (4).
- d. Remove sleeve bushings (1, 11).
- e. Remove electromagnetic relay (12).
- f. Remove diaphragm valve (9), armature valve (5), and helical compression spring (10).
- g. Remove fluid filters (6, 7).

**REPAIR**

Repair at this level of maintenance is by replacement of worn or defective parts.

**ASSEMBLY**

- a. Install fluid filters (6, 7).
- b. Assemble helical compression spring (10), armature valve (5), diaphragm valve (9), and armature valve guide (4).
- c. Install electromagnetic relay (12).

- d. Install bushings (1, 11).
- e. Install armature valve guide (4).
- f. Install valve body (8) on mounting bracket (3).
- g. Install machine screw (2).
- h. Refer to paragraphs 2-84 .

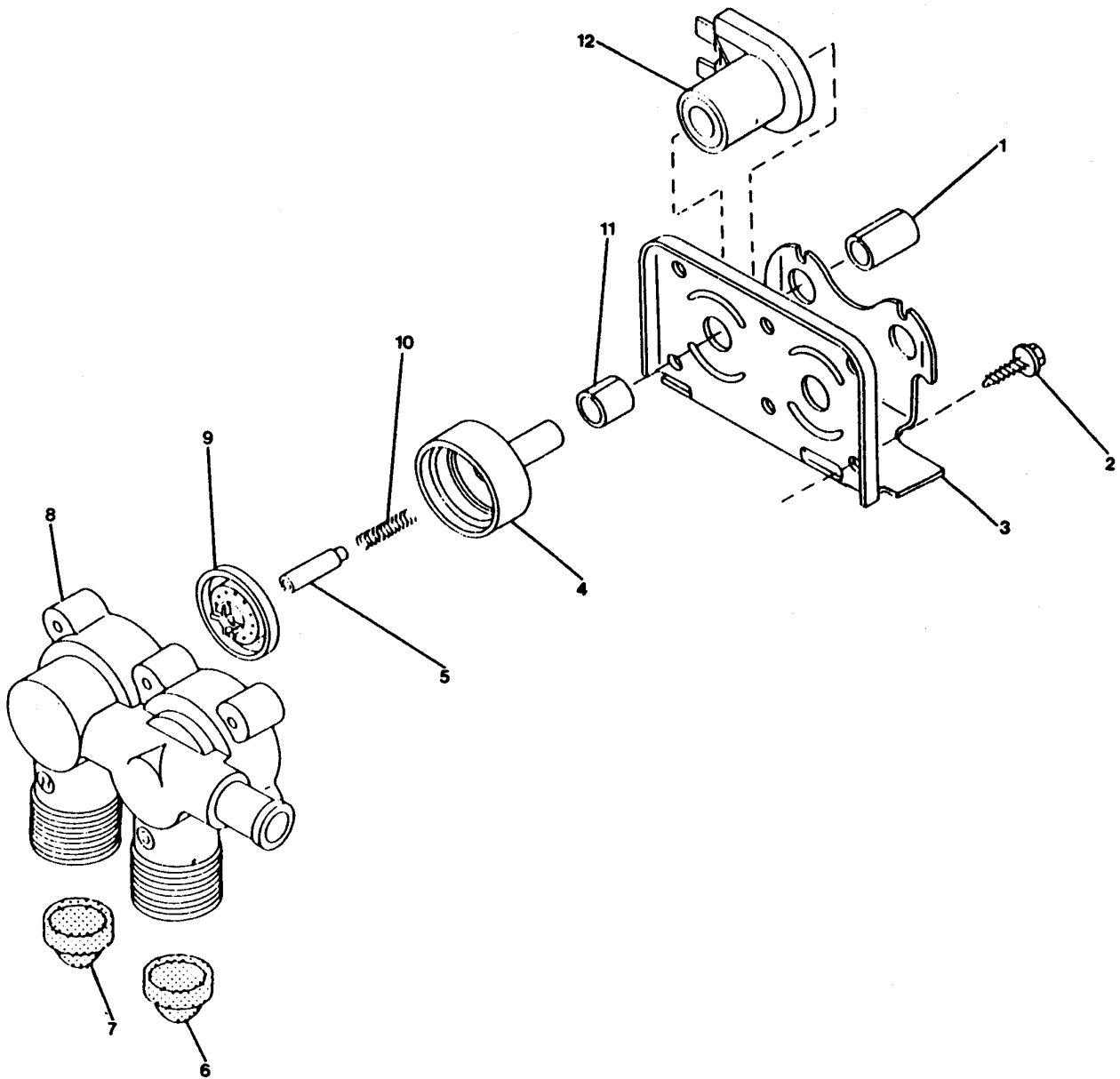

FIGURE 3-87. Washer Machine Water Mixing Valve.

---

**3-94. Repair Washer Machine Agitator Post Assembly. (Figure 3-88)**

---

This task covers:

a. Disassembly

b. Repair

c. Assembly

---

**INITIAL SETUP:**Tools

Tool kit, general mechanic's,  
5180-00-699-5273

Equipment Condition

Washer machine.  
Agitator post assembly removed,  
para. 2-85 .

**DISASSEMBLY**

- a. Remove tapered pin (1) and drive block (9).
- b. Remove retaining ring (4), washer (5), and thrust washer (3).
- c. Remove drive shaft (8) and flat washers (2, 7).

**REPAIR**

Repair at this level of maintenance is by replacement of worn or defective parts.

**ASSEMBLY**

- a. Install flat washer (2, 7) and drive shaft (8) in agitator post (6).
- b. Install thrust washer (3), washer (5), and retaining ring (4).
- c. Install drive block (9) and tapered pin (1).
- d. Refer to paragraphs 2-85 .

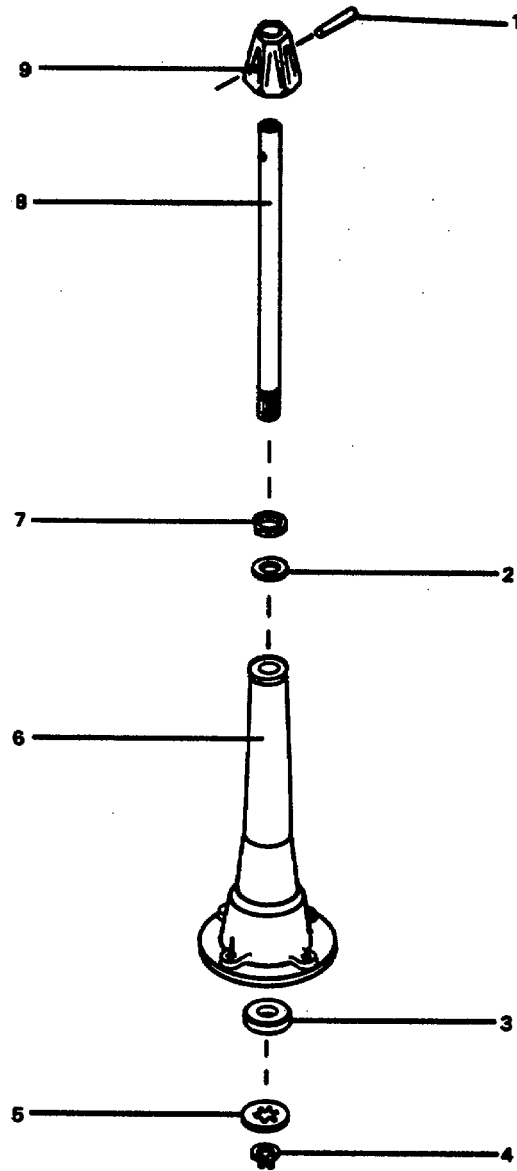

FIGURE 3-88. *Washer Machine Agitator Post Assembly.*

---

**3-95. Repair Washer Machine Agitator Post Assembly. (Figure 3-88)**

---

**This task covers:**

- a. Repair
- 

**INITIAL SETUP:**

Tools

Tool kit, general mechanic's,  
5180-00-699-5273

Equipment Condition

Washer machine removed, para. 2-83 .  
Outer tub, cover, and pressure hose  
group removed, para. 2-86 .

**REPAIR**

Repair at this level of maintenance is by replacement of worn or defective parts.

---

**3-96. Repair Washer Machine Lint Filter, Wash Tub, and Hub Group**

---

**This task covers:**

- a. Repair
- 

**INITIAL SETUP:**

Tools

Tool kit, general mechanic's,  
5180-00-699-5273

Equipment Condition

Washer machine removed, para. 2-83 .  
Lint filter, wash tube and hub group  
removed, para. 2-86 .

**REPAIR**

Repair at this level of maintenance is by replacement of worn or defective parts.

---

**3-97. Repair Washer Machine Bearing Housing, Brake/Pulley and Pivot Dome Group.**

---

**This task covers:**

- a. Repair.

---

**INITIAL SETUP:**

Tools

Tool kit, general mechanic's,  
5180-00-699-5273

Equipment Condition

Washer machine removed, para. 2-83 .  
Bearing housing, brake/pulley and  
pivot dome group removed, para.  
2-86 .

**REPAIR**

Repair at this level of maintenance is by replacement of worn or defective parts.

---

**3-98. Repair Washer Machine Transmission Group**

---

**This task covers:**

- a. Repair
- 

**INITIAL SETUP:**

Tools

Tool kit, general mechanic's,  
5180-00-699-5273

Equipment Condition

Washer machine removed, para. 2-83 .  
Transmission group removed, para.  
2-86 .

**REPAIR**

Repair at this level of maintenance is by replacement of worn or defective parts.



---

**3-99. Repair Washer Machine Mechanical Transmission. (Figure 3-89)**

---

**This task covers:****a. Disassembly****b. Repair****c. Assembly**

---

**INITIAL SETUP:**Tools

Tool kit, general mechanic's,  
5180-00-699-5273  
Tool kit, No. 357P3

Equipment Condition

Washer machine removed, para. 2-83 .  
Mechanical transmission removed,  
para. 2-86 .

Materials/Parts

Mechanical transmission  
P/N 28430

**DISASSEMBLY**

- a. Remove hexagon head capscrew (19) and lockwasher (18).
- b. Remove transmission cover (23) and transmission case assembly (10).
- c. Remove clutch roller (16) and washer (24).
- d. Remove shaft (15).
- e. Remove special screw (12), lockwasher (13), flat washer (14), and pinion drive (25).
- f. Remove reduction gear (26).
- g. Remove internal gear (11).
- h. Remove rack (9) and slide (8).
- i. Remove retaining ring (1) and coupling and shaft (2).
- j. Remove bearing (3) and seal (4).
- k. Remove agitator gear (7).
- l. Remove bearing (6) and seal (5).
- m. Remove seal (21), bushing sleeve (22), and seal (20).
- n. Remove dowel pin (17).

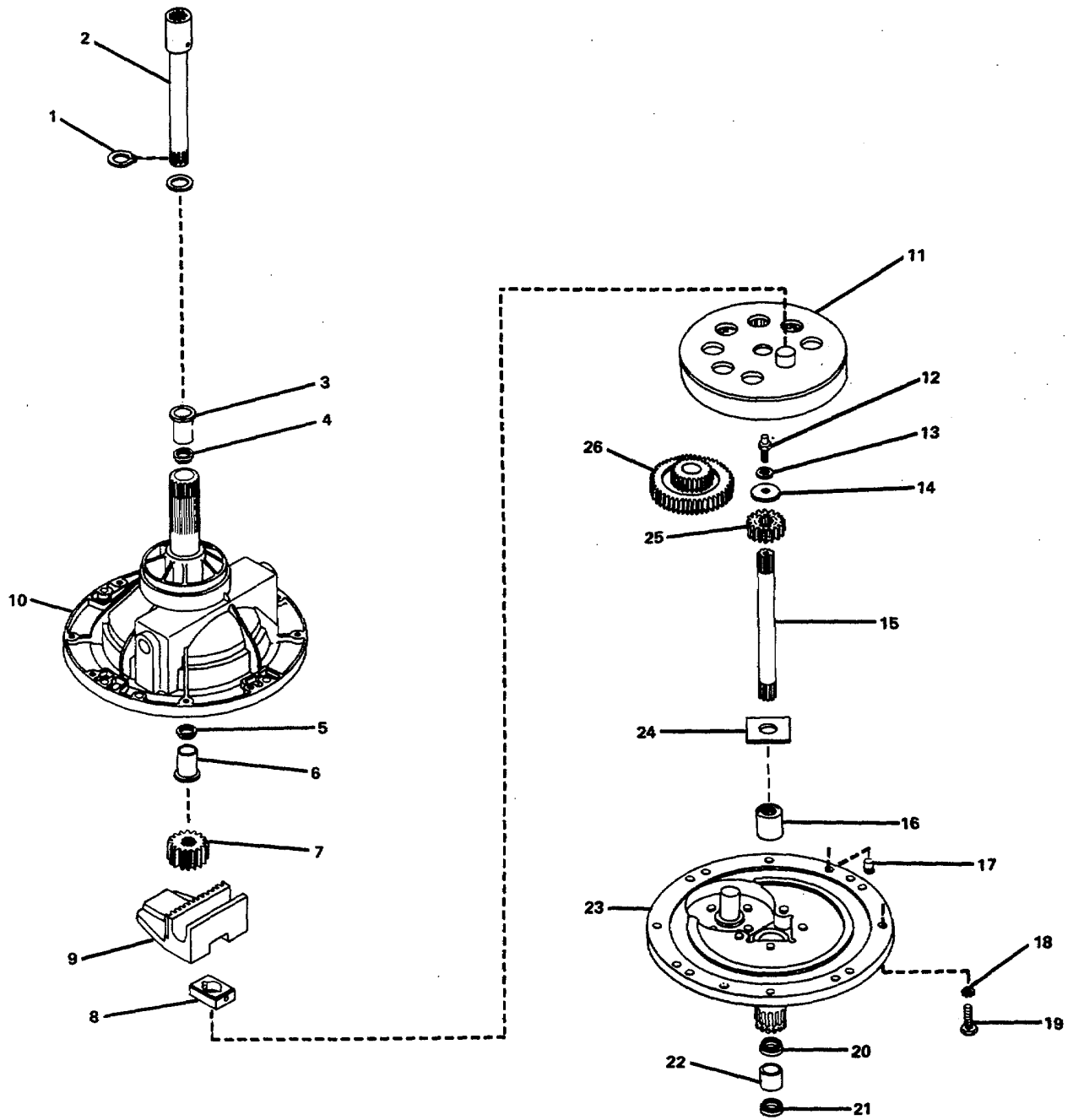

FIGURE 3-89. *Washer Machine Mechanical Transmission.*

## REPAIR

Repair at this level of maintenance is by replacement of worn or defective parts.

## ASSEMBLY

- a. Install dowel pin (17).
- b. Install seal (20), bushing sleeve (22), and seal (21).
- c. Install bearing (6) and seal (5).
- d. Install agitator gear (7).
- e. Install seal (4) and bearing (3).
- f. Install coupling and shaft (2) and retaining ring (1).
- g. Install slide (8) and rack (9).
- h. Install internal gear (11).
- i. Install reduction gear (26).
- j. Install pinion drive (25), flat washer (14), lockwasher (13) and special screw (12).
- k. Install shaft (15).
- l. Install washer (24) and clutch roller (16).
- m. Install transmission case assembly (10) and transmission cover (23).
- n. Install lockwasher (18) and hexagon head capscrew (19).
- o. Refer to paragraphs 2-83 and 2-86 .

---

**3-100. Repair Washer Machine Pump and Hoses Group.**

---

**This task covers:**

**a. Repair**

---

**INITIAL SETUP:**

Tools

Tool kit, general mechanic's,  
5180-00-699-5273

Equipment Condition

Washer machine removed, para. 2-83 .  
Pump and hoses group removed, para  
2-87 .

**REPAIR**

Repair at this level of maintenance is by replacement of worn or defective parts.

---

**3-101. Repair Washer Machine Centrifugal Pump. (Figure 3-90)**

---

This task covers:

a. Disassembly

b. Repair

c. Assembly

---

**INITIAL SETUP:**Tools

Tool kit, general mechanic's,  
5180-00-699-5273

Equipment Condition

Washer machine removed, para 2-83 .  
and centrifugal pump removed,  
para. 2-87 .

Materials/Parts

Pump parts kit P/N 349P3

---

**DISASSEMBLY**

- a. Remove spring clip (5).
- b. Remove pump cover (1) from pump body (4).
- c. Remove pump body and impeller assembly (3).

**REPAIR****NOTE**

Pump parts kit contains instructions for replacement.

Repair at this level of maintenance is by replacement of parts kit (2) items.

**ASSEMBLY**

- a. Install pump body and impeller assembly (3).
- b. Install pump cover (1) on pump body (4).
- c. Install spring clip (5).

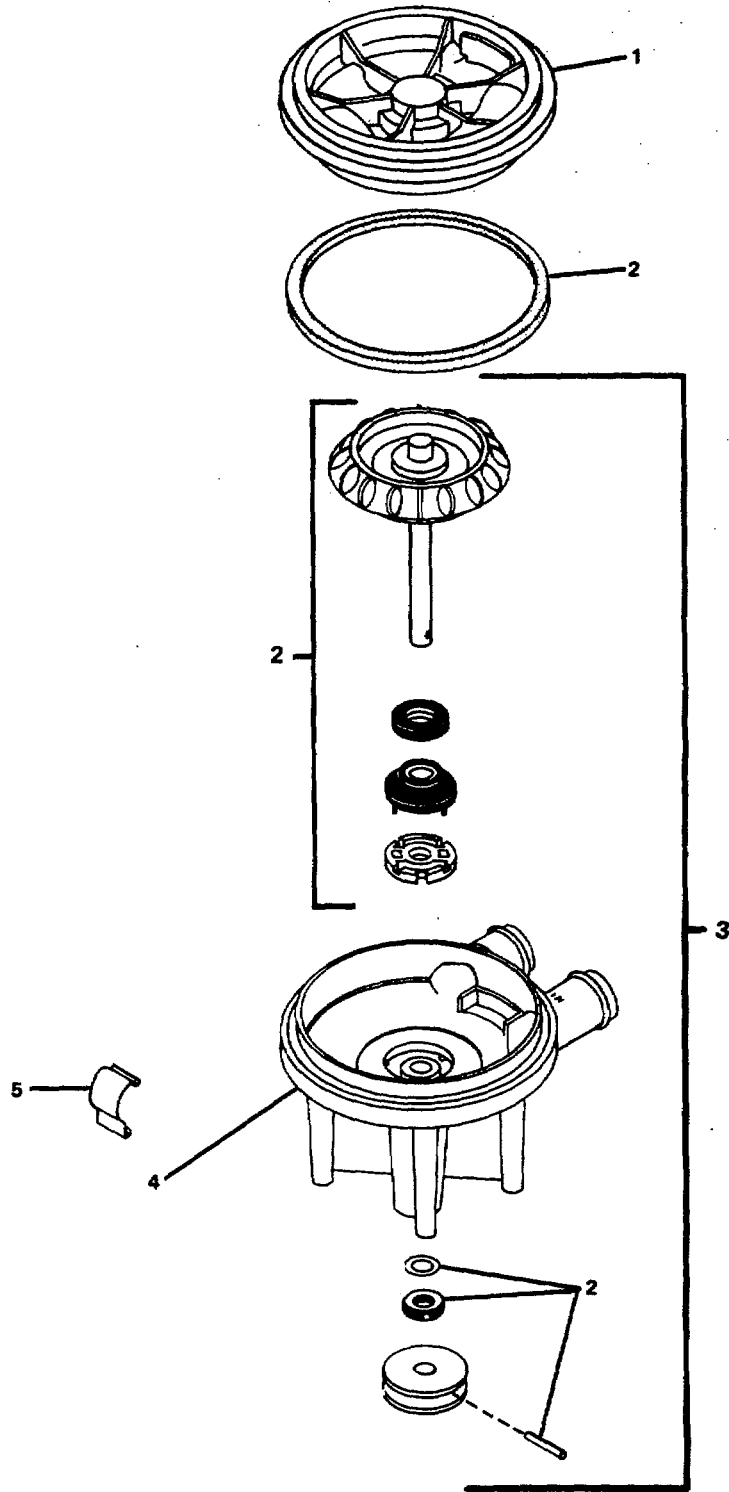

FIGURE 3-90. *Washer Machine Centrifugal Pump.*

---

**3-102. REPAIR WASHER MACHINE MOTOR AND IDLER.**

---

**This task covers:**

- a. Repair
- 

**INITIAL SETUP:**

Tools

Tool kit, general mechanic's,  
5180-00-699-5273

Equipment Condition

Washer machine removed, para. 2-83 .  
Motor and idler removed, para. 2-88 .

Materials/Parts

V-belt P/N 27155  
V-belt P/N 28808  
Motor P/N 27179

---

**REPAIR**

Repair at this level of maintenance is by replacement of V-belts (18, 19, Figure 2-74) and motor (3).

---

**3-103. REPAIR LAUNDRY DRYER TUMBLER (Figure 3-91).**

---

**This task covers:****a. Disassembly****b. Repair****c. Assembly**

---

**INITIAL SETUP:**Tools

Tool kit, general mechanic's,  
5180-00-699-5273  
Tool kit, electrician's,  
5180-00-391-1087

Equipment Condition

Laundry dryer tumbler removed,  
para. 2-89 .

Materials/Parts

Temperature switch P/N 56576  
Indicator light P/N.25851  
Push switch P/N 55882  
Switch P/N 56052  
Warning tags, Item 1, Appendix C

---

**DISASSEMBLY**

- a. Remove hexagon head capscrews (10, 11, Sheet 1).
- b. Remove hexagon head capscrew (9) and lockwashers (8, 20), and plain hexagon nut (19).
- c. Remove machine screw (3) and speed nut (4).
- d. Remove hexagon head capscrews (6) and rear cover (7).
- e. Remove control hood (5) and one gasket (21) from each end of hood.
- f. Tag and disconnect electrical leads.
- g. Remove control panel (13) and control support (15).
- h. Remove knob assembly (1), knurled nut (2), lockwasher (17), and temperature switch (18).
- i. Remove indicator light (16).
- j. Remove plain hexagon nut (14) and push switch (12).
- k. Remove hexagon head capscrew (26, Sheet 2).



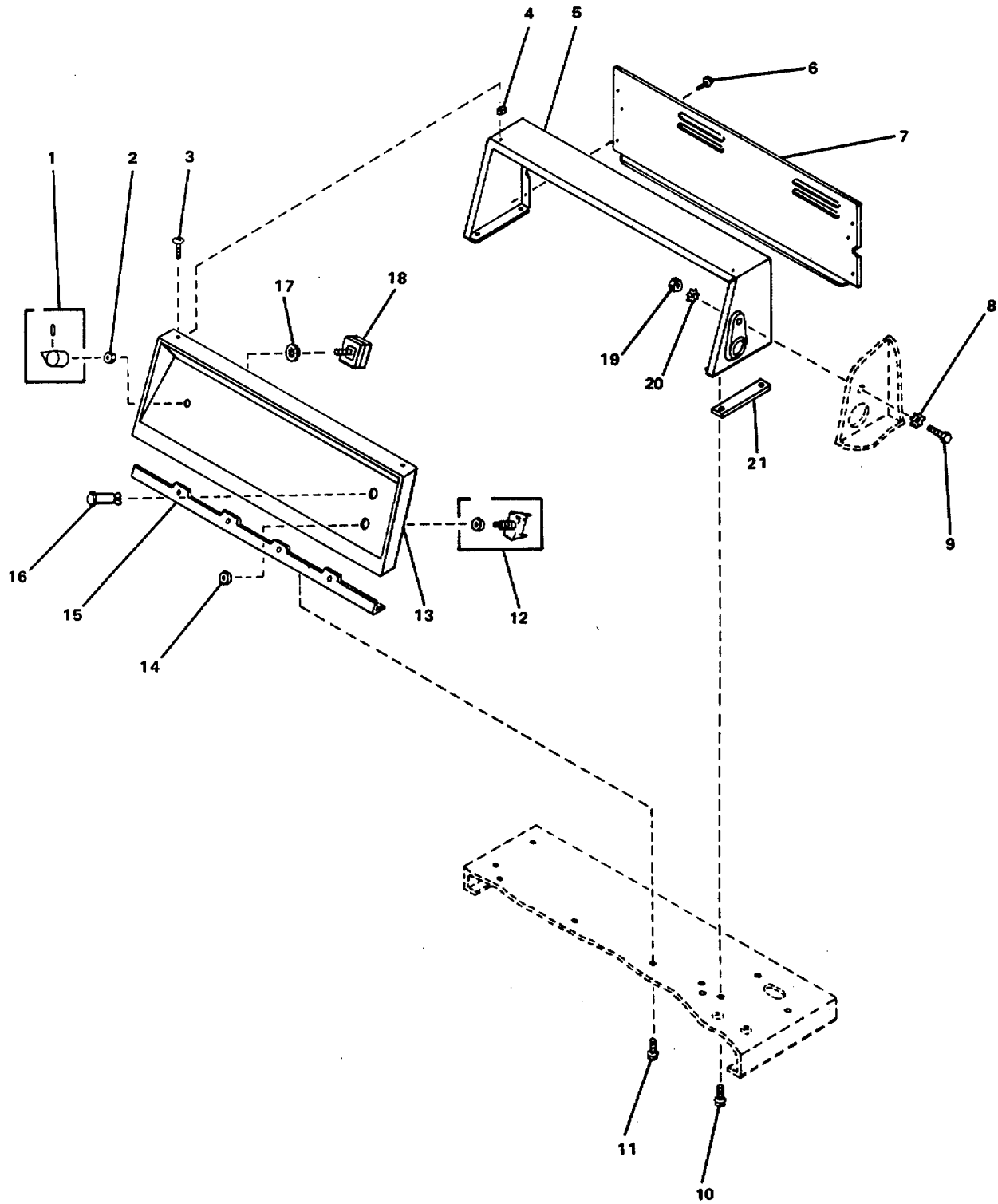

FIGURE 3-91. *Repair Laundry Dryer Tumbler (Sheet 1 of 5).*

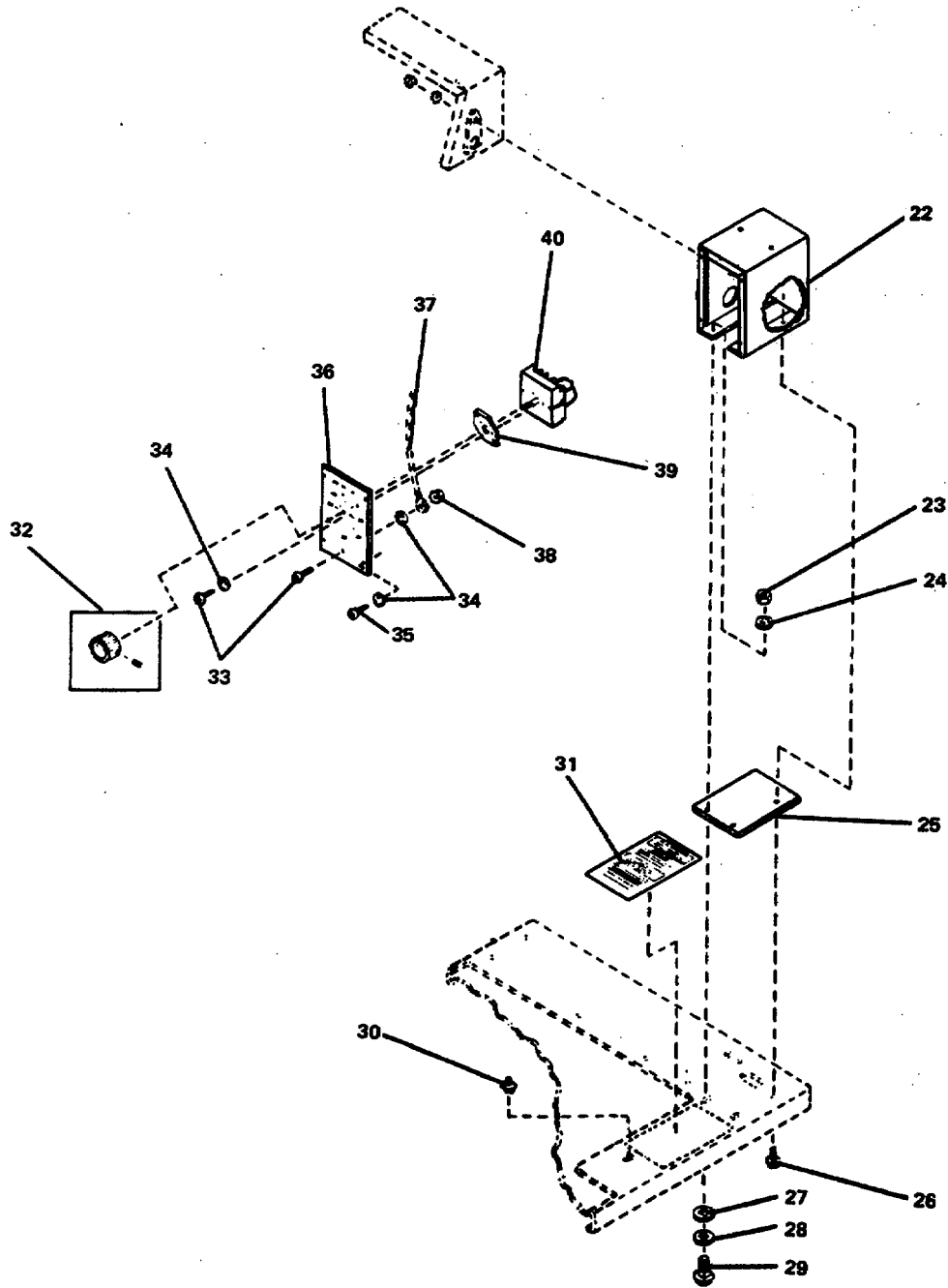

FIGURE 3-91. Repair Laundry Dryer Tumbler (Sheet 2 of 5).

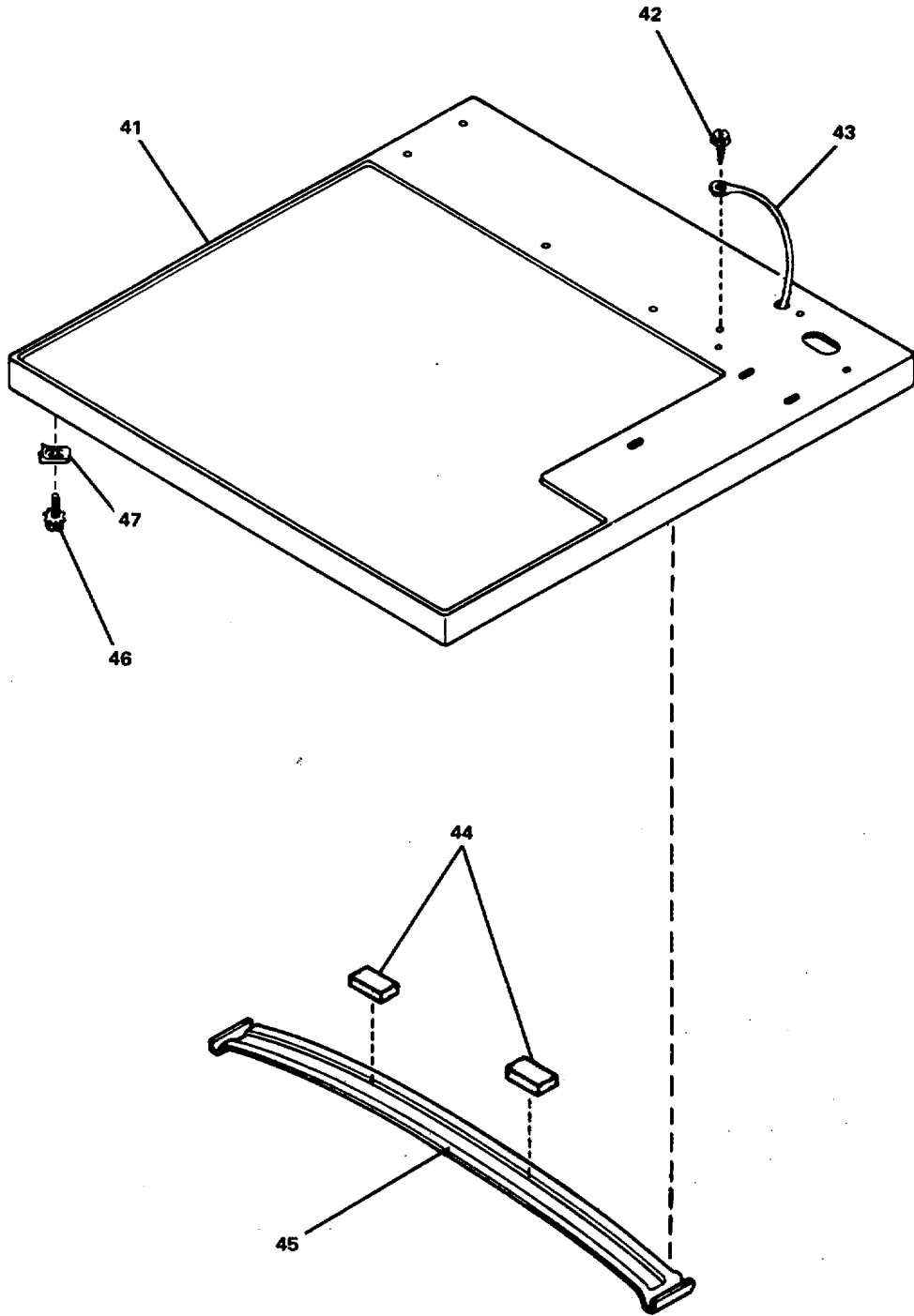

FIGURE 3-91. *Repair Laundry Dryer Tumbler (Sheet 3 of 5).*

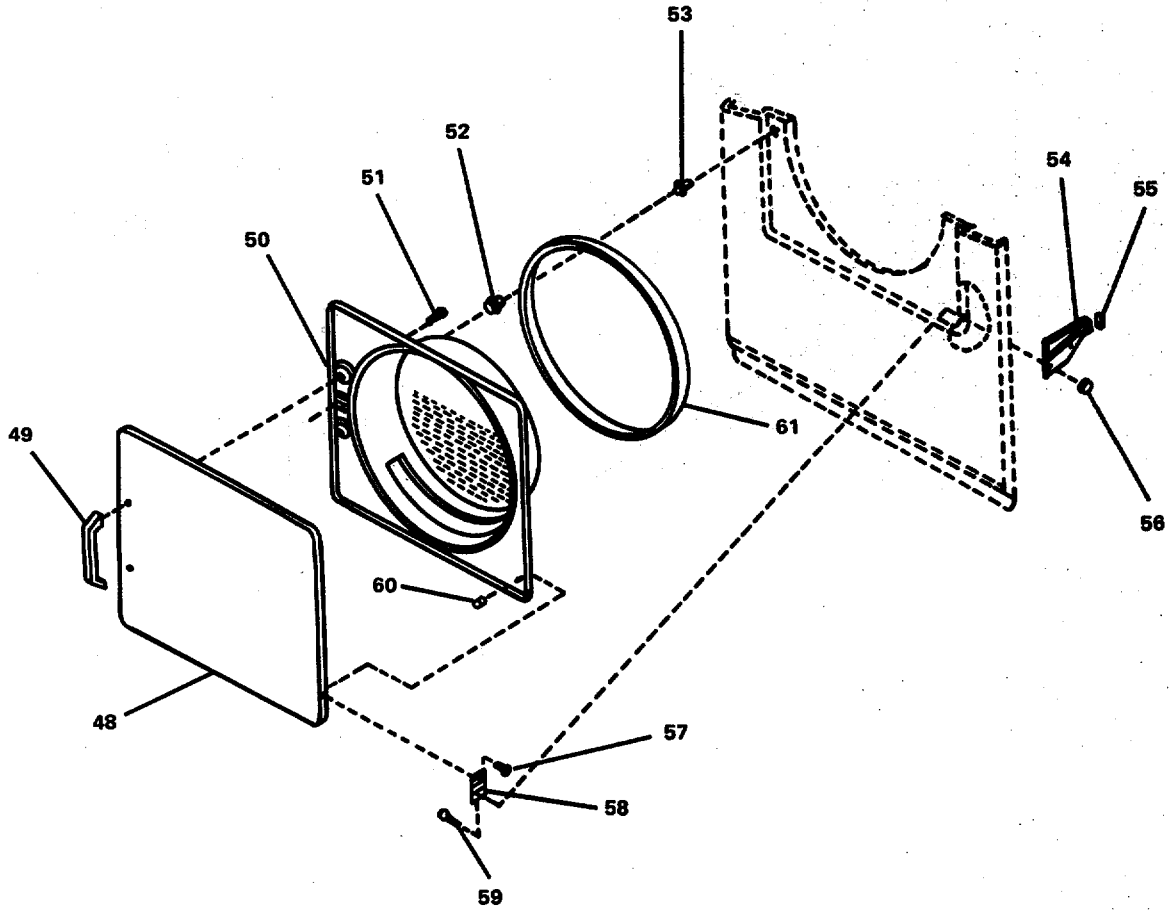

FIGURE 3-91. *Repair Laundry Dryer Tumbler (Sheet 4 of 5).*

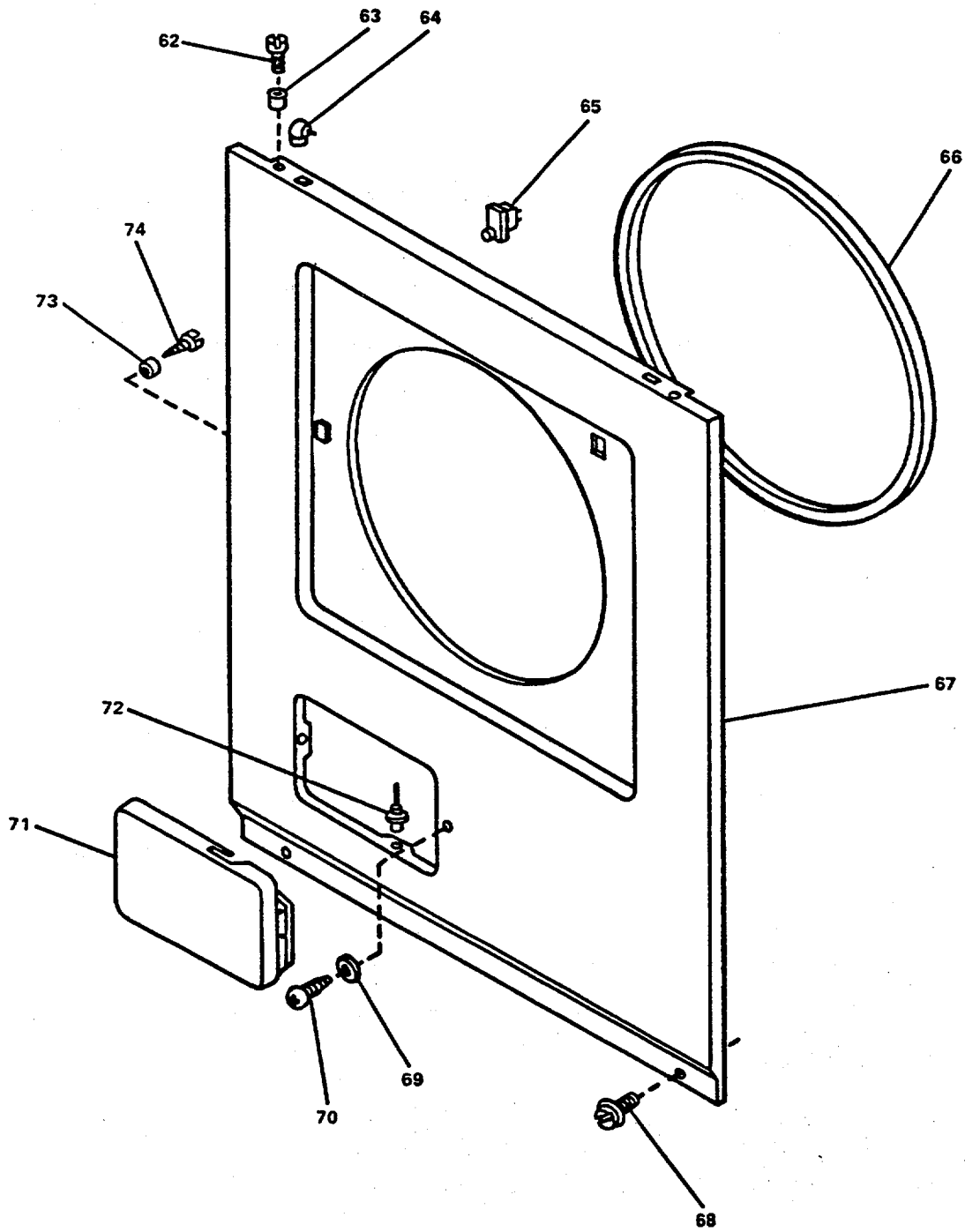

FIGURE 3-91. *Repair Laundry Dryer Tumbler (Sheet 5 of 5).*

- l. Remove carriage bolt (29), flat washer (28) washer (27), lockwasher (24) and plain hexagon nut (23).
- m. Remove timer case (22) and gasket (25).
- n. Remove rivet (30) and decal (31).
- o. Remove timer knob assembly (32).
- p. Remove machine screws (33, 35), lockwasher (34), ground wire (37) and locknut (38).
- q. Remove timer plate (36), timer spacer (39) and timer assembly (40).
- r. Remove hexagon head capscrew (42, Sheet 3) and ground wire (43).
- s. Remove assembled washer screw (46) and speed nut (47).
- t. Remove cabinet top (41).
- u. Remove resilient mounts (44).
- v. Remove top brace (45).
- w. Remove locknut (56, Sheet 4), bracket support (54) and machine screw (57).
- x. Remove pad (55).
- y. Remove hexagon head capscrew (51) and dryer door handle (49).
- z. Remove inner door panel (50) and outer door panel.
- aa. Remove machine screw (59), hinge (58), speed nut (60), and access door (48).
- ab. Remove nonmetallic seal (61).
- ac. Remove dryer door striker (52) and dryer door catch (53).
- ad. Remove machine screw (70, Sheet 5) and flat washer (69).
- ae. Remove access door (71).
- af. Remove support rivet (72).
- ag. Remove hexagon head capscrew (68).
- ah. Remove machine screw (62) and sleeve bushing (63).
- ai. Remove hold-down clip (64).
- aj. Remove machine screw (74) and sleeve bushing (73).
- ak. Remove dryer front panel (67).
- al. Remove seal (66).

am. Remove switch (65).

## REPAIR

Repair at this level of maintenance is by replacement of temperature switch (18, Sheet 1), indicator light (16), push switch (12), and switch (65, Sheet 5).

## ASSEMBLY

- a. Install switch (65).
- b. Install seal (66).
- c. Install dryer front panel (67).
- d. Install sleeve bushing (73) and machine screw (74).
- e. Install hold-down clip (64).
- f. Install sleeve bushing (63) and machine screw (62).
- g. Install hexagon head capscrew (68).
- h. Install support rivet (72).
- i. Install access door (71).
- j. Install flat washer (69) and machine screw (70).
- k. Install dry door catch (53, Sheet 4) and dryer door striker (52).
- l. Install nonmetallic seal (61).
- m. Install access door (48), speed nut (60), hinge (58), and machine screw (59).
- n. Install outer door and inner door panel (50).
- o. Install dryer door handle (49) and hexagon head capscrew (51).
- p. Install pad (55).
- q. Install machine screw (57), bracket support (54), and locknut (56).
- r. Install top brace (45, Sheet 3).
- s. Install resilient mounts (44).
- t. Install cabinet top (41).
- u. Install speed nut (47) and assembled washer screw (46).
- v. Install ground wire (43) and hexagon head capscrew (42).

- w. Install timer assembly (40, Sheet 2), timer spacer (39), and timer plate (36).
- x. Install locknut (38), ground wire (37), lockwasher (34), and machine screws (33, 35).
- y. Install timer knob assembly (32).
- z. Install rivet (30) and decal (31).
- aa. Install gasket (25) and timer case (22).
- ab. Install plain hexagon nut (23), lockwasher (24), washer (27), flat washer (28) and carriage bolt (29).
- ac. Install hexagon head capscrew (26).
- ad. Install push switch (12, Sheet 1) and plain hexagon nut (14).
- ae. Install indicator light (16).
- af. Install pressure switch (18), lockwasher (17), knurled nut (2), and knob (1).
- ag. Install control support (15) and control panel (13).
- ah. Remove tag and connect electrical leads.
- ai. Install gasket (21) and control hood (5).
- aj. Install rear cover (7) and hexagon head capscrew (6).
- ak. Install speed nut (4) and machine screw (3).
- al. Install plain hexagon nut (19), lockwashers (8, 20), and hexagon head capscrew (9).
- am. Install hexagon head capscrew (10, 11).
- an. Refer to paragraph 2-89.



---

**3-104. REPAIR DRYER FRONT BULKHEAD AND CYLINDER ASSEMBLY.**

---

**This task covers:**

- a. Repair
- 

**INITIAL SETUP:**

Tools

Tool kit, general mechanic's,  
5180-00-699-5273

Equipment Condition

Dryer front bulkhead and cylinder  
assembly removed, para. 2-90 .

Materials/Parts

Lint filter P/N 57025

---

**REPAIR**

Repair at this level of maintenance is by replacement of lint filter (15, Figure 2-76).

---

**3-105. REPAIR DRYER REAR BULKHEAD AND CYLINDER ROLLER GROUP.**

---

**This task covers:**

- a. Repair
- 

**INITIAL SETUP:**

Tools

Tool kit, general mechanic's,  
5180-00-699-5273

Equipment Condition

Dryer rear bulkhead and cylinder roller  
group removed, para. 2-91 .

Materials/Parts

Rear bulkhead and cylinder group  
P/N FIG 430 RPSTL

---

**REPAIR**

Repair at this level of maintenance is by replacement of worn or defective parts.

---

**3-106. REPAIR DRYER HEATER BOX GROUP.**

---

**This task covers:**

- a. Repair
- 

**INITIAL SETUP:**

Tools

Tool kit, general mechanic's,  
5180-00-699-5273  
Tool kit, electrician's,  
5180-00-391-1087

Equipment Condition

Dryer heater box group removed,  
para. 2-92 .

Materials/Parts

Nonimmersion type electric heater  
element P/N 56179  
Warning tags, Item 1, Appendix C

---

**REPAIR**

Repair at this level of maintenance is by replacement of nonimmersion type electric heater element (22, Figure 2-78).

---

**3-107. REPAIR DRYER MOTOR AND EXHAUST FAN GROUP.**

---

**This task covers:**

- a. Repair
- 

**INITIAL SETUP:**Tools

Tool kit, general mechanic's,  
5180-00-699-5273  
Tool kit, electrician's,  
5180-00-391-1087

Equipment Condition

Dryer removed, para. 2-89 .  
Dryer motor and exhaust fan group  
removed, para. 2-93 .

Materials/Parts

Thermostatic switch P/N 56470  
High thermostatic switch  
P/N 57015  
Low limit thermostatic switch  
P/N 56591  
V-Belt P/N 56095  
Electrical switch P/N 53249  
Warning tags, Item 1, Appendix C

---

**REPAIR**

Repair at this level of maintenance is by replacement of thermostatic switch (22), high thermostatic switch (27), low limit thermostatic switch (29), V-belt (2), and electrical switch (34). Refer to Figure 2-76 .

---

**3-108. REPAIR DRYER CABINET, EXHAUST DUCT, AND BASE GROUP.**

---

**This task covers:**

- a. Repair
- 

**INITIAL SETUP:**

Tools

Tool kit, general mechanic's,  
5180-00-699-5273

Equipment Condition

Dryer removed, para. 2-89 .  
Dryer cabinet, exhaust duct, and base  
group removed, para. 2-94 .

---

**REPAIR**

Repair at this level of maintenance is by replacement of worn or defective parts.

<b>MAINTENANCE OF MISCELLANEOUS PUMPS/MOTORS</b>
--

---

**3-109. REPAIR CENTRIFUGAL PUMP UNIT (FRESH WATER).**

---

This task covers:

a. Disassembly

b. Repair

c. Assembly

---

**INITIAL SETUP:**

Tools

Tool kit, general mechanic's,  
5180-00-699-5273  
Tool kit, electrician's,  
5180-00-391-1087  
Adjustable spanner wrench  
P/N 7492

Equipment Condition

Pump/motor set removed (para. 2-81).  
Position pump/motor set on a clean flat  
surface for disassembly and repair.

Materials/Parts

Rubber bushing P/N 4231  
Pump, raceway P/N 9789-9  
Centrifugal pump impeller  
P/N 9788 HT-9  
Preformed packing P/N 255-5716  
Plain seal P/N 8991  
Annular ball bearing  
P/N 9144

---

**DISASSEMBLY** (Figure 3-92)

- a. Remove four hex head capscrews (1).
- b. Remove two pipe plugs (8).
- c. Remove plug (3).
- d. Remove case (2).
- e. Remove rubber bushing (5).
- f. Remove two machine screws (7).
- g. Remove pump raceway (6).

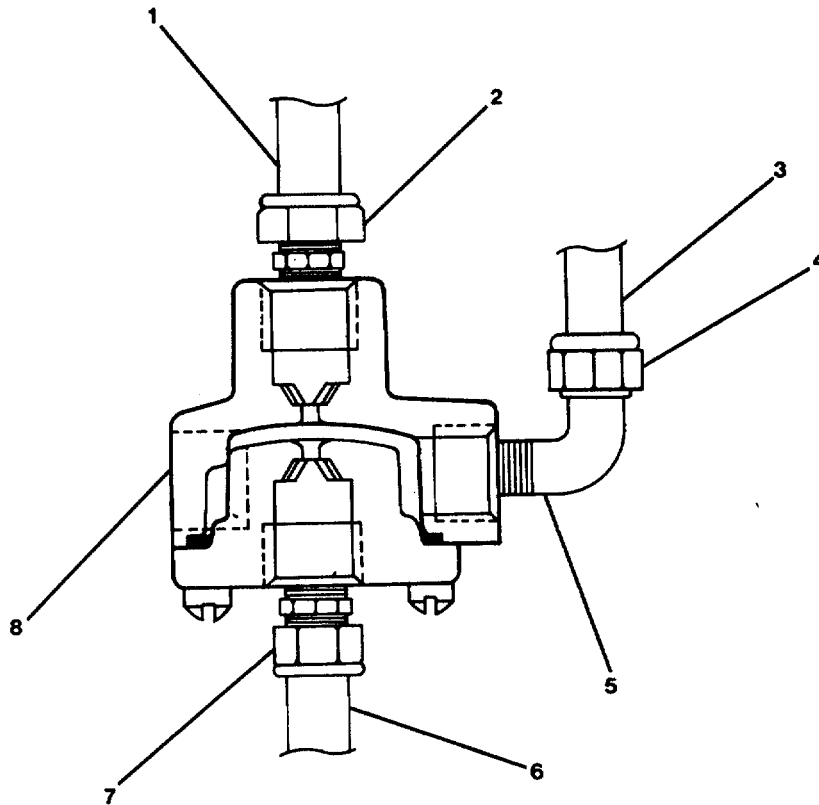

FIGURE 3-92. *Fresh Water Centrifugal Pump.*

NOTE

To assist removal of centrifugal pump impeller retaining hex nut, the pump shaft is held stationary by placing-either a screwdriver or nail of suitable size through hole provided on the close coupled pump shaft (Figure 3-93).

- h. Install screwdriver or nail through hole in pump shaft (11, Figure 3-92).
- i. Remove hex plain nut (9).
- j. Remove impeller (10) by pulling straight off shaft.

- k. Remove key (12).
- l. Remove preformed packing (4).
- m. Remove plain seal (14).
- n. Remove screw driver/nail from hole in pump shaft.
- o. Remove four hexhead capscrews (19).
- p. Separate pump shaft (11), impeller adjustment screw (16), annular ball bearing (21) and pump frame (13) as a unit from motor shaft (22) and motor housing flange (20).
- q. Remove hex head capscrew (17).
- r. Remove pump lock (18).
- s. Using spanner wrench, turn impeller adjustment screw (16) counterclockwise until screw (16) separates from pump frame (13). Remove spanner wrench.
- t. Remove annular ball bearing (21) from pump shaft (11).
- u. Slide pump shaft (11) through pump frame (13) toward case end of pump.
- v. Remove impeller adjusting screw (16) from pump shaft.
- w. Remove washer (15) from pump shaft.
- x. Remove pump shaft (11).

## REPAIR

Repair of fresh water centrifugal pump consists of replacing rubber bushing (5), pump raceway (6), centrifugal pump impeller (10), preformed packing (4), plain seal (14), and annular ball bearing (21).

## ASSEMBLY

- a. Install pump shaft (11) into pump frame (13) from case end of pump.
- b. Slide pump shaft through pump frame toward motor end of pump.
- c. Replace washer (15) on pump shaft.
- d. Install impeller adjusting screw (16) on pump shaft.
- e. Install annular ball bearing (21) on pump shaft.
- f. Use spanner wrench to install impeller adjusting screw (16) on pump frame (13).



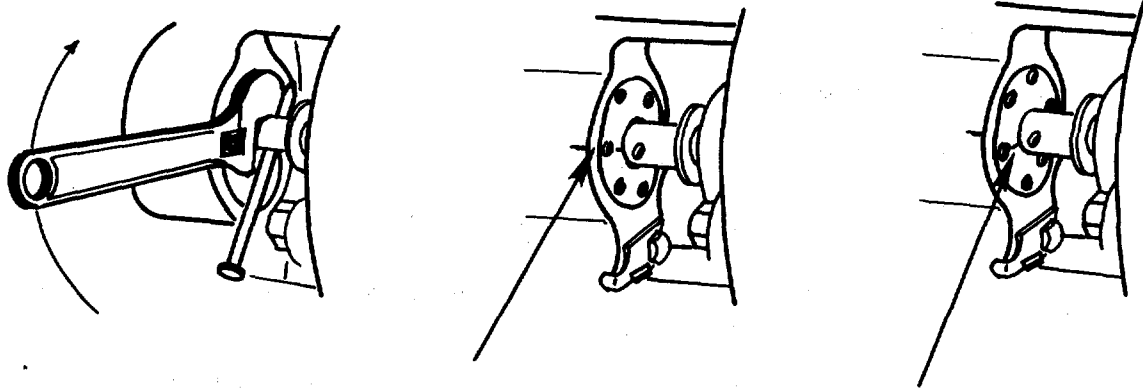

FIGURE 3-93. *Impeller Running Clearance Adjustment.*

NOTE

Pump lock and hexhead capscrew are replaced when impeller running clearance adjustment is completed.

- g. Install pump shaft (11), impeller adjustment screw (16), annular ball bearing (21) and pump frame (13) as a unit on motor shaft (22) and motor housing flange (20).
- h. Install four hexhead capscrews (19).

NOTE

To assist installation of centrifugal pump impeller, pump shaft is held-stationary by placing either a screwdriver or nail of suitable size through hole provided on the close coupled pump shaft.

- i. Install screwdriver or nail through hole in pump shaft (11).
- j. Install plain seal (14).
- k. Install preformed packing (4).
- l. Install key (12).
- m. Install impeller (10).
- n. Install hex plain nut (9).
- o. Install pump raceway (6).
- p. Install two machine screws (7).
- q. Install rubber bushing (5).

- r. Install case (2).
- s. Install plug (3)
- t. Install two pipe plugs (8).
- u. Install four hex head capscrews (1).
- v. Adjust impeller running clearance (Figure 3-93).
  - (1) To check pump for slack or binding, rotate pump shaft back and forth with screwdriver or nail used during assembly.
  - (2) Use spanner wrench to rotate impeller adjusting screw clockwise until a slight drag is felt as the impeller comes in contact with the pump raceway. At this point, make a mark on the pump frame and across one of the spanner wrench holes on impeller adjusting screw.
  - (3) Use spanner wrench to rotate impeller adjusting screw in opposite direction (counterclockwise) to back the impeller off and provide clearance between impeller and pump raceway. The proper clearance is obtained by moving the impeller adjustment screw approximately one half the distance between two of the spanner wrench holes as indicated by the reference marks made in step (2) above.
  - (4) Remove spanner wrench.
  - (5) Remove screwdriver or nail from hole in pump shaft.
  - (6) Insert tab end of pump lock (18, Figure 3-92) into nearest spanner wrench hole as other end of pump lock is aligned with mounting screw hole (Figure 3-93).
  - (7) Install hex head capscrew (17, Figure 3-92).

---

**3-110. REPAIR CENTRIFUGAL PUMP UNIT (FRESH WATER BOOSTER) (Figure 3-94).**

---

**This task covers:****a. Disassembly****b. Repair****c. Assembly**

---

**INITIAL SETUP:**Tools

Tool kit, general mechanic's,  
5180-00-699-5273  
Tool kit, electrician's,  
5180-00-391-1087  
Torque wrench, 5120-00-242-3264  
(0-50 ft-lb)

Equipment Condition

Pump removed, para. 2-97 .

Materials/Parts

Gasket P/N 2584  
Centrifugal pump impeller P/N 1129  
Shaft seal assembly P/N CFSP52322  
Shoulder shaft P/N 1829

---

**DISASSEMBLY**

- a. Remove four hex head capscrews (2).
- b. Remove two plugs (9).
- c. Remove casing (8).
- d. Remove gasket (6) and discard.
- e. Remove machine bolt (10) and flat washer (11).
- f. Remove impeller (12) by unscrewing counterclockwise from shoulder shaft (5).
- g. Remove shaft seal assembly (13).
- h. Remove four hex head capscrews (7).
- i. Remove support head (3).
- j. Remove setscrew (4).
- k. Remove shoulder shaft (5).

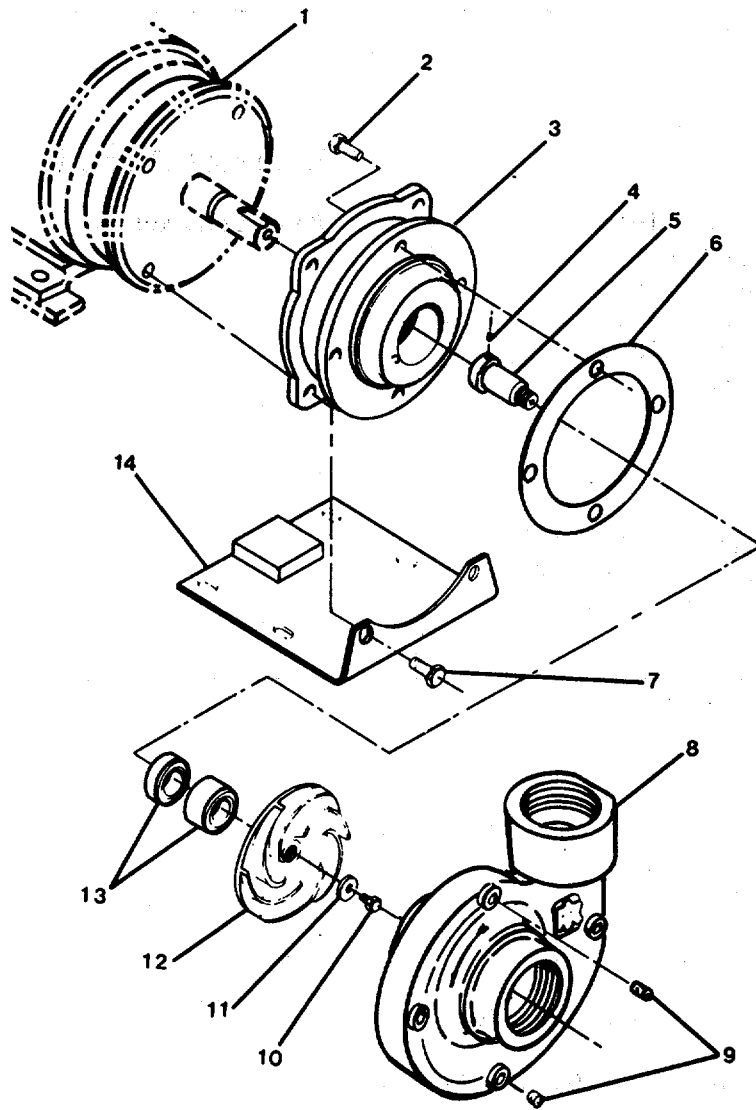

FIGURE 3-94. Centrifugal Pump Unit (Fresh Water Booster).

- l. Remove motor foot (14).
- m. Remove electric motor (1).

## REPAIR

Repair of fresh water booster centrifugal pump consists of replacing gasket (6), centrifugal pump impeller (12), shaft seal assembly (13), and shoulder shaft (5).

## ASSEMBLY

- a. Attach support head (3) and motor foot (14) to electric motor (1) with four hex head capscrews (7). Tighten to 10 to 15 ft-lb torque (13.6 to 20.3 N•m).
- b. Install shoulder shaft (5) onto motor shaft.
- c. Replace setscrew (4) in shoulder shaft (5) but do not tighten at this time.
- d. Place shaft seal assembly (13) onto shoulder shaft (5) followed by impeller (12). Attach with machine bolt (10) and flat washer (11).
- e. Tighten machine bolt to 2 to 4 ft-lb torque (2.7 to 5.4 N•m).
- f. Position gasket (6) on support head (3) and attach casing (8) with four hex head capscrews (2). Tighten to 25 ft-lb torque (33.9 N•m).
- g. Replace two plugs (9).
- h. Adjust impeller running clearance.
  - (1) Move shoulder shaft (5) forward (towards casing) until impeller (12) is touching casing (8).
  - (2) Insert feeler gauge between shoulder on shaft and nose of support head (3) Measure gap.
  - (3) Add 0.010 inch to feeler gauge and move shoulder shaft back (toward motor) until feeler goes in between shoulder on shaft and nose of support head.
  - (4) Tighten set screw (4) to 5 to 6 ft-lb torque (6.8 to 8.1 N•m).
  - (5) Remove feeler gauge.



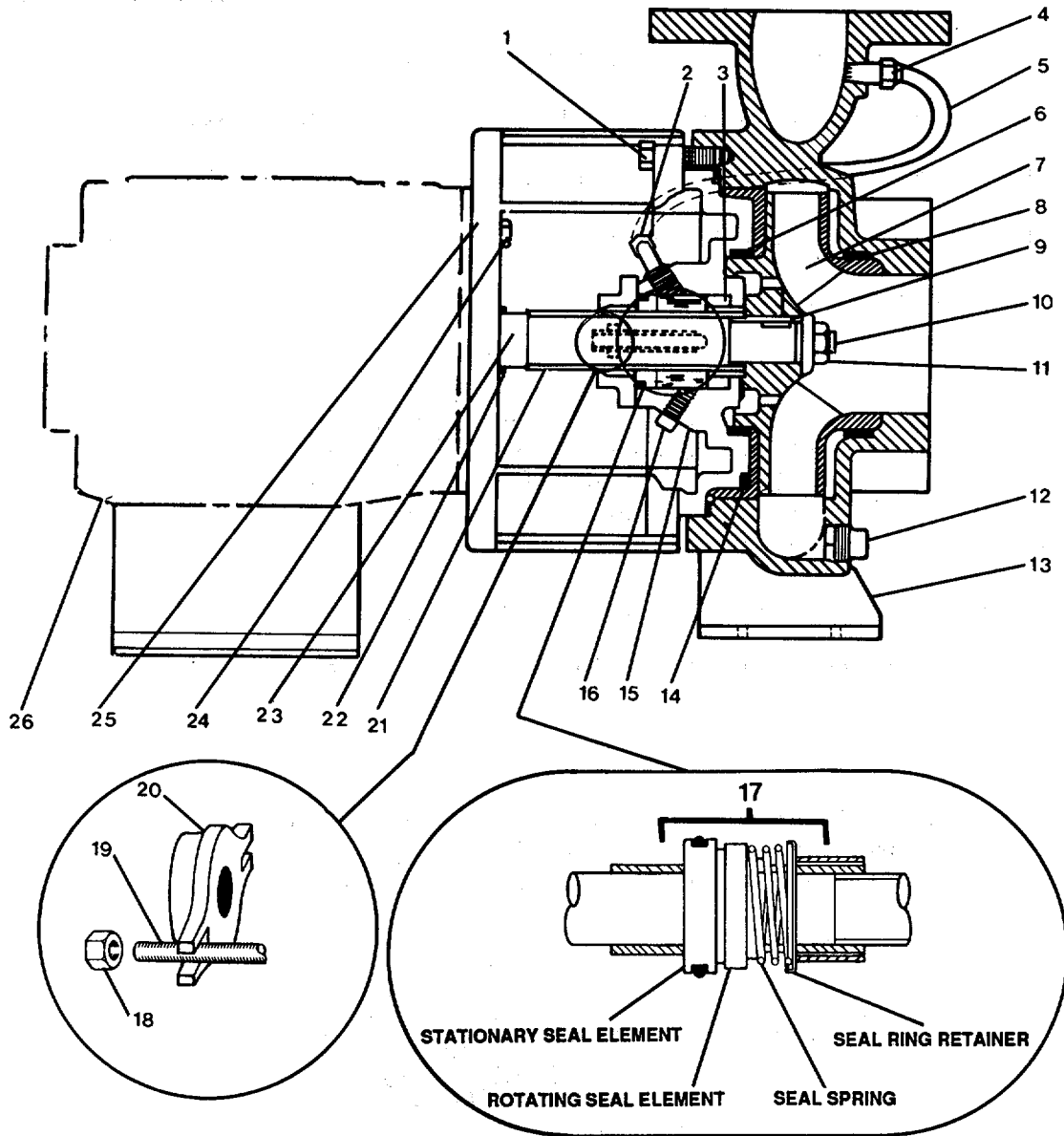

FIGURE 3-95. Auxiliary Seawater Cooling Centrifugal Pump.

- l. Slide sleeve spacer (3) off shaft sleeve (21) from casing end of pump.
- m. Slide mechanical seal (17) off shaft sleeve (21) from casing end of pump.
- n. Pull shaft sleeve (21) with gland (20) intact, from motor shaft (23).
- o. Remove gland (20) from shaft sleeve (21).
- p. Remove synthetic rubber deflector (22) from motor shaft.
- q. Remove wearing ring (8) from suction port in casing (13).
- r. Remove wearing ring (6) from stuffing box cover (15).
- s. Motor adapter removal:

NOTE

Do not remove the adapter from the motor unless the motor is to be repaired or replaced. If the adapter is removed, it will necessitate repositioning of motor adapter to the motor shaft.

- (1) Remove four hex head capscrews (24).
- (2) Separate motor adapter (25) from motor shaft (26).

**REPAIR**

Repair of centrifugal pump (auxiliary seawater cooling) consists of replacing: centrifugal pump impeller (7), mechanical seal (17), preformed packing (14), metal tube assembly (5), and wearing ring (8), (6).

**ASSEMBLY**

- a. Motor adapter installation:

NOTE

If necessary, mount the motor adapter to the motor using four hexhead capscrews. Be certain adapter is mounted such that the drain hole is on the bottom. Make snug, but do not tighten capscrews as final positioning of the motor adapter to motor shaft is required.

- (1) Position motor adapter (25) on motor (26) with mounting screw holes aligned.
- (2) Install four hex head capscrews. Make snug, but do not tighten capscrews at this time.



- b. Install wearing ring (6) in stuffing box cover (15).
- c. Install wearing ring (8) in suction port of casing (13).
- d. Install synthetic rubber deflector (22) on motor shaft (23).
- e. Install gland (20) on shaft sleeve (21).
- f. Install shaft sleeve (21) with gland (20) intact, on motor shaft.
- g. Install mechanical seal (17) on shaft sleeve (21) from casing end of pump.
- h. Install sleeve spacer (3) on shaft sleeve (21) from casing end of pump.
- i. Install preformed packing (14) on stuffing box cover (15).
- j. Install stuffing box cover (15) on sleeve spacer (3) and shaft sleeve (21) with gland studs (18) aligned with gland (20).
- k. Install two gland nuts (18) on gland studs (19) and secure gland (20) to stuffing box cover (15). Tighten gland nuts until both surfaces make contact.
- l. Install shoulder shaft (10) by screwing clockwise on motor shaft (23).
- m. Install impeller key (9).
- n. Install centrifugal pump impeller (7).
- o. Install impeller nut (11) by turning nut clockwise.
- p. Install casing (13) over stuffing box assembly, being careful to not pinch or disturb preformed packing (14) as mounting screw holes are aligned.
- q. Install eight hex head capscrews (1). Tighten opposing capscrews evenly around the adapter until the stuffing box has been drawn evenly into the casing. Then alternately tighten each capscrew to 25 ft-lb torque (33.9 N•m).
- r. Install plug (12).
- s. Install metal tube assembly (5) by connecting fittings (2) and (4).
- t. Motor adapter positioning:
  - (1) Position the motor to the pump by upending the assembly on the motor end and tapping the pump with a soft face hammer in different directions until the impeller can be turned freely in the casing. This is accomplished by reaching into the suction port and turning the impeller by hand.
  - (2) Secure motor adapter (25) to motor (26) with four hex head capscrews (24).

---

**3-112. REPAIR ROTARY PUMP UNIT (FUEL OIL TRANSFER, PRELUBE OIL TRANSFER, DIRTY LUBE OIL). (Figure 3-96).**

---

**This task covers:****a. Disassembly****b. Repair****c. Assembly**

---

**INITIAL SETUP:**Tools

Tool kit, general mechanic's,  
5180-00-699-5273

Equipment Condition

Appropriate rotary pump unit removed as  
specified in para. 2-101, 2-104, or  
2-107 .

Materials/Parts

Machine key P/N F39C

---

**DISASSEMBLY****NOTE**

This procedure may also be used for the prelube oil transfer pump and dirty lube oil pump since all three pumps are the same.

- a. Remove spider coupling (7) and half coupling (6) from shaft (11).
- b. Remove machine key (5) from shaft.
- c. Remove two hex plain nuts (10), lockwashers (9), and hex head capscrews (8) securing outboard bearing (4) to shaft bracket (12).
- d. Remove outboard bearing from shaft.
- e. Remove four hex head capscrews (3) and lockwashers (2) securing pump (1) to shaft bracket (12)
- f. Separate rotary pump from bracket.

**REPAIR**

Repair of rotary pump unit consists of replacing machine key (5).

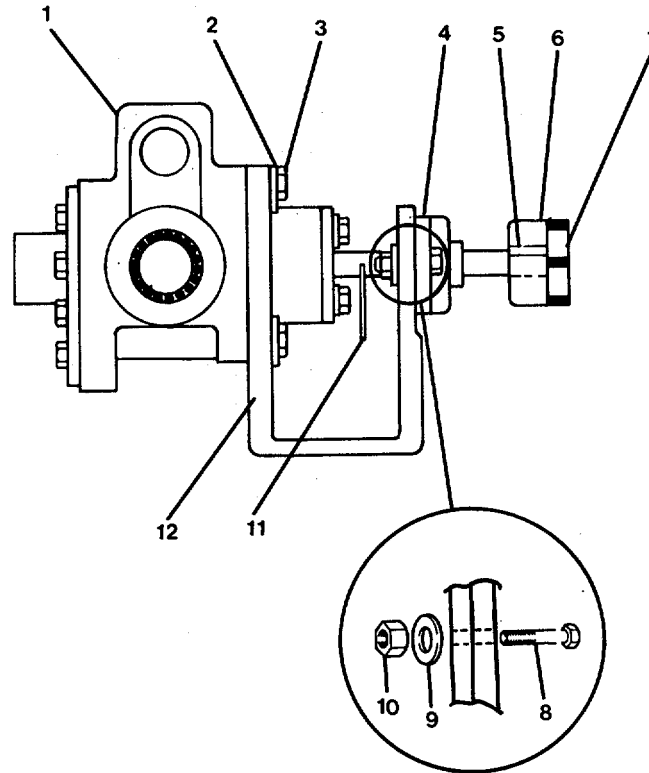

FIGURE 3-96. Pump Shaft Assembly.

#### ASSEMBLY

- a. Position pump (1) on shaft bracket (12).
- b. Secure pump to shaft bracket with four lockwashers (2) and hex head capscrews (3).
- c. Install outboard bearing (4) on shaft (11) and mounting screw holes aligned.
- d. Secure outboard bearing to shaft bracket with two hex head capscrews (8), lockwashers (9) and hex plain nuts (10).
- e. Install machine key (5) on shaft (11).
- f. Install half coupling (6).
- g. Install spider coupling (7) on half coupling.
- h. Replace appropriate rotary pump unit as specified in paragraph 2-101, 2-104, or 2-107.

---

### 3-113. REPAIR ROTARY PUMP (FUEL OIL TRANSFER, PRELUBE OIL TRANSFER, DIRTY LUBE OIL). (Figure 3-97).

---

**This task covers:****a. Disassembly****b. Repair****c. Assembly****INITIAL SETUP:**Tools

Tool kit, general mechanic's,  
5180-00-699-5273  
Adjustable spanner wrench  
P/N 7492

Equipment Condition

Rotary pump removed as specified in  
para. 3-112 .

Materials/Parts

Preformed packing P/N F24E, F28E,  
F56E(2)  
Shaft seal assembly P/N F18AM.  
Sleeve bearing P/N F11B(2)  
Expansion plug P/N DP43  
Pump rotor P/N D2026F1  
Shaft and pinion assembly P/N  
DR2OC13MOC  
Gasket screw P/N E68C

---

**DISASSEMBLY****NOTE**

This procedure may also be used for the prelube oil transfer pump and dirty lube oil pump since all three pumps are the same.

**a. Rotary Pump Assembly.**

- (1) Remove four hex head capscrews (1) securing gland (2) to casing (7).  
Remove gland.
- (2) Remove preformed packing (3) and shaft seal assembly (4).
- (3) Remove snap ring (5).
- (4) Remove sleeve bearing (6).
- (5) Remove eight hex head capscrews (14).

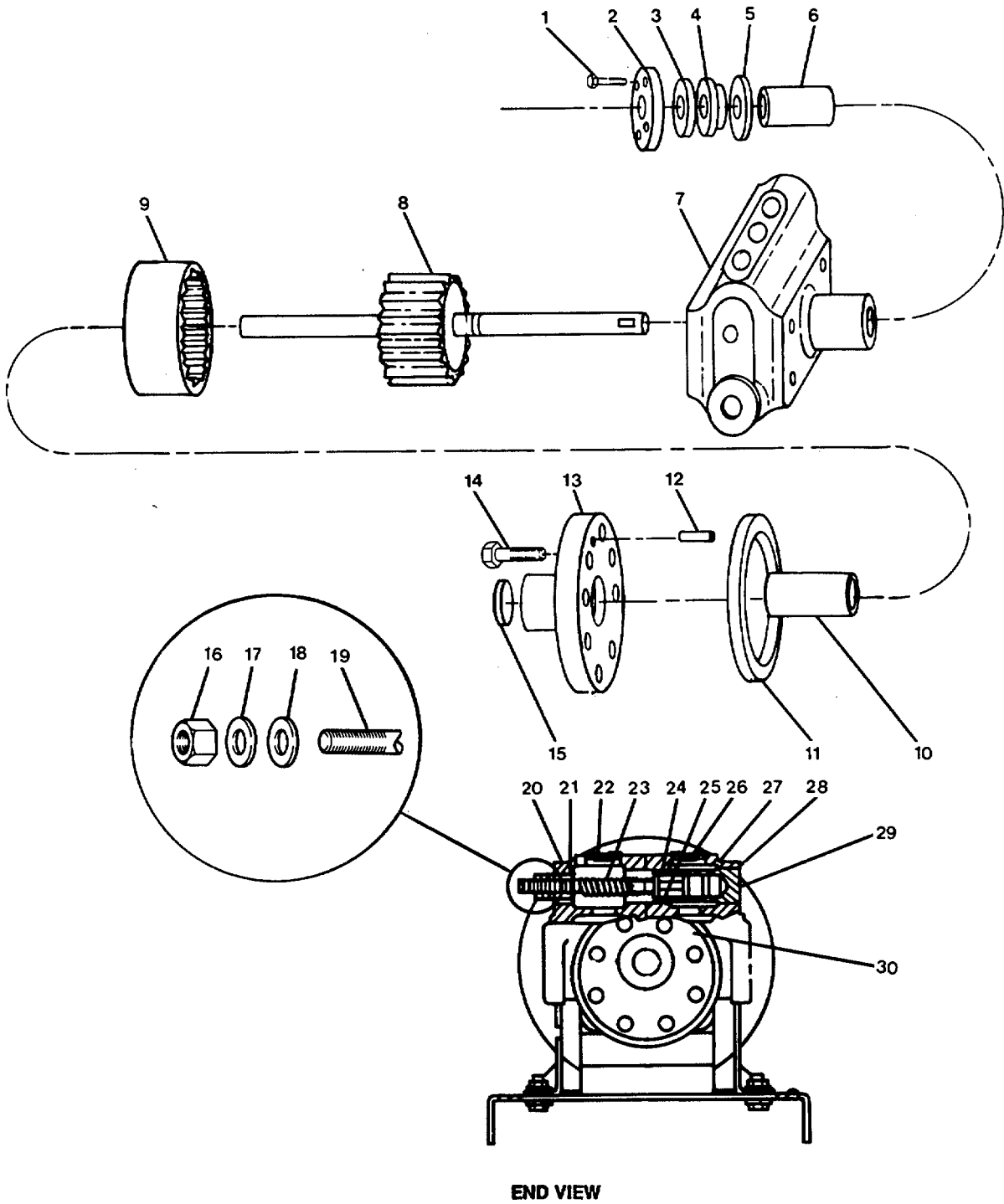

FIGURE 3-97. *Rotary pump and Relief Valve Assembly.*

- (6) Remove cover (13).
- (7) Remove expansion plug (15). Use hammer and punch to knock plug out of cover.
- (8) Remove roll pin (12).
- (9) Remove performed packing (11) and sleeve bearing (10).
- (10) Remove pump rotor (9).
- (11) Remove shaft and pinion assembly (8).

b. Relief Valve Assembly.

- (1) Remove locknut (16), gasket screw (17) and bonnet (18) from adjusting screw (19).
- (2) Remove retaining ring (20).
- (3) Remove performed packing (21).
- (4) Remove adjusting screw (19), spring (21) and poppet (25).
- (5) Remove retaining ring (29).
- (6) Remove cage (28) from casing.
- (7) Remove performed packings (24 and 27).
- (8) Remove pipe plugs (22) and (26) from casing.

## REPAIR

Repair of rotary pump unit consists of replacing performed packing (3, 11, 21, 24, 27), shaft seal assembly (4), sleeve bearings (6, 10), expansion plug (15), pump rotor (9), shaft and pinion assembly (8), and gasket screw (17).

## ASSEMBLY

a. Relief Valve Assembly.

- (1) Install pipe plugs (22, 26) on casing (7).
- (2) Install performed packings (24 and 27).
- (3) Install cage (28) on casing.
- (4) Install retaining ring (29).
- (5) Install poppet (25), spring (21) and adjusting screw (19).
- (6) Install performed packing (21).

(7) Install retaining ring (20).

(8) Install bonnet (18), gasket screw (17) and locknut (16) on adjusting screw (19).

b. Rotary Pump Assembly.

(1) Install shaft and pinion assembly (8).

(2) Install pump rotor (9).

(3) Install sleeve bearing (10) and performed packing (11).

(4) Install roll pin (12) in mounting hole (30) on casing (7).

(5) Install expansion plug (15) on cover (13).

(6) Position cover (13) on casing with roll pin (12) and mounting screwholes aligned.

(7) Secure cover to casing with eight hex head capscrews (14).

(8) Install sleeve bearing (7).

(9) Install snap ring (5).

(10) Install shaft seal assembly (4) and performed packing (3).

(11) Position gland (2) on casing with mounting screwholes aligned.

(12) Secure gland to casing with four hex head capscrews (1).

(13) Rotary pump replaced-as specified in paragraph 3-112 .

---

**3-114. Repair Centrifugal Pump Unit (Reduction Gear Cooling Water). (Figure 3-98)**

---

**This task covers: a. Disassembly, b. Repair, c. Assembly.**

---

**INITIAL SETUP**Tools      Equipment Condition

Tool kit, general mechanic's,  
5180-00-699-5273      Centrifugal pump unit removed as  
specified in paragraph 2-110 .  
Tool kit, electrician's,  
5180-00-391-1087  
Torque wrench, 5120-00-242-3264  
(0-50 ft-lb)

Materials/Parts

Gasket P/N 2584  
Rotary pump impeller P/N 1129  
Shaft spring loaded seal assembly  
P/N 1802  
Machine key P/N 11A9

---

**DISASSEMBLY**

- a. Remove two plugs (8).
- b. Remove four hex head capscrews (14).
- c. Remove casing (9).
- d. Remove gasket (10).
- e. Remove machine bolt (11) and flat washer (12).
- f. Remove impeller (13) by unscrewing counterclockwise from shoulder shaft (3).
- g. Remove shaft seal assembly (7).
- h. Remove four hex head capscrews (5).
- i. Remove support head (6) from motor (1).
- j. Remove machine key (4).
- k. Remove setscrew (2).



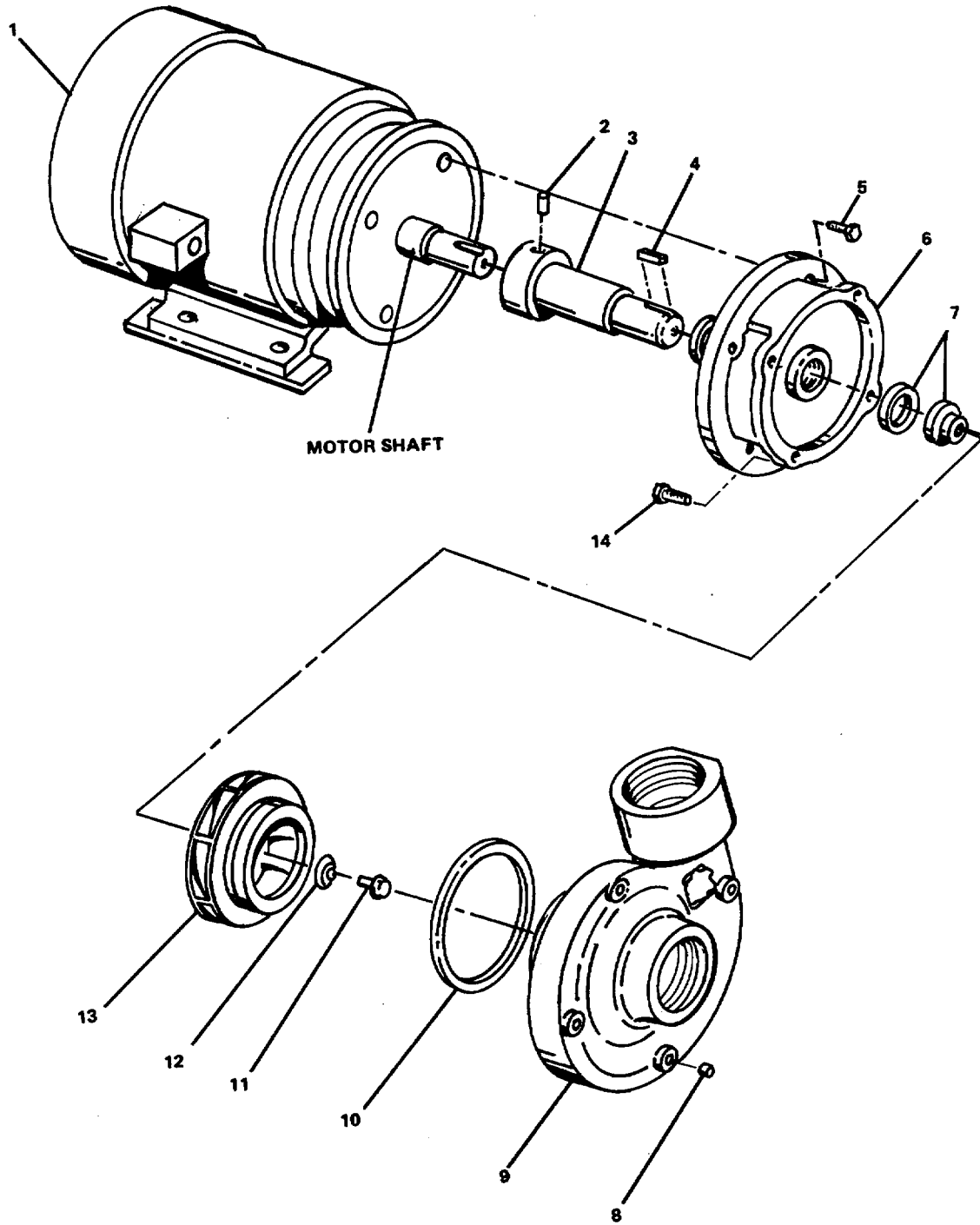

FIGURE 3-98. Rotary Pump (Reduction Gear Cooling Water).

1. Remove shoulder shaft (3) from motor shaft.

## REPAIR

Repair of reduction gear cooling water centrifugal pump consist of replacing gasket (6), centrifugal pump impeller (12), shaft seal assembly (13), and shoulder shaft (5).

## ASSEMBLY

- a. Position support head (6) on electric motor (1). Install four hex head capscrews (5). Tighten to 10 to 15 ft-lb torque (13.6 to 20.3 Nm).
- b. Install shoulder shaft (3) onto motor shaft.
- c. Install setscrew (2) in shoulder shaft (3) but do not tighten at this time.
- d. Place shaft seal assembly (7) onto shoulder shaft (3) followed by impeller (13). Attach with machine bolt (11) and flat washer (12).
- e. Tighten machine bolt to 2 to 4 ft-lb torque (2.7 to 5.4 Nm).
- f. Position gasket (10) on support head (6) and attach casing (9) with four hex head capscrews (14). Tighten to 25 ft-lb torque (33.9 Nm).
- g. Replace two plugs (8).
- h. Adjust impeller running clearance.
  - (1) Move shoulder shaft (3) forward (towards casing) until impeller (13) is touching casing (9).
  - (2) Insert feeler gauge between shoulder on shaft and nose of support head (6) Measure gap.
  - (3) Add 0.010 inch to feeler gauge and move shoulder shaft back (toward motor) until feeler goes in between shoulder on shaft and nose of support head.
  - (4) Tighten setscrew (2) to 5 to 6 ft-lb torque (6.8 to 8.1 Nm).
  - (5) Remove feeler gauge.
  - (6) Pump replaced as specified in paragraph 2-110 .

MAINTENANCE OF CONTROLS SYSTEM
--------------------------------

---

### 3-115. Replace/Repair Steering Control and Autopilot System.

---

**This task covers: a. Inspection, b. Removal, c. Repair, d. Replacement.**

---

#### INITIAL SETUP

<u>Tools</u>	<u>Equipment Condition</u>
Tool kit, electrician's, 5180-00-391-1087	Electrical power to steering control and autopilot system OFF and tagged "Out of Service - Do Not Operate." (TM 55-1905-223-10)
<u>Materials/Parts</u>	
Gyro interface assembly P/N 510-173 Wheel controller, helm unit P/N 510-172 Warning tags, Item 1, Appendix C	

---

#### INSPECTION

Visually check all wiring and component mounting very carefully for possible causes or damage from vibration, chafing, strain, overheating, and short circuits from loose wires.

#### REMOVAL

- a. Remove Gyro Interface Assembly.
  - (1) Unfasten two latching screws (4, Figure 3-99) securing starboard side access panel (3) to pilothouse control console (1).
  - (2) Remove access panel.
  - (3) Tag and disconnect electrical wiring at cable fittings (3, Figure 3-100).
  - (4) Remove capscrews (2) securing gyro interface assembly (1) to starboard side (interior) of pilothouse control console.
  - (5) Remove gyro interface assembly.
- b. Remove Wheel Controller. Helm Unit. (Figure 3-101)
  - (1) Remove capscrew (9) and washer (10) securing wheel to shaft (7). Remove wheel. Retain shaft key (8) for replacement of wheel.
  - (2) Disconnect cable from connector (11).

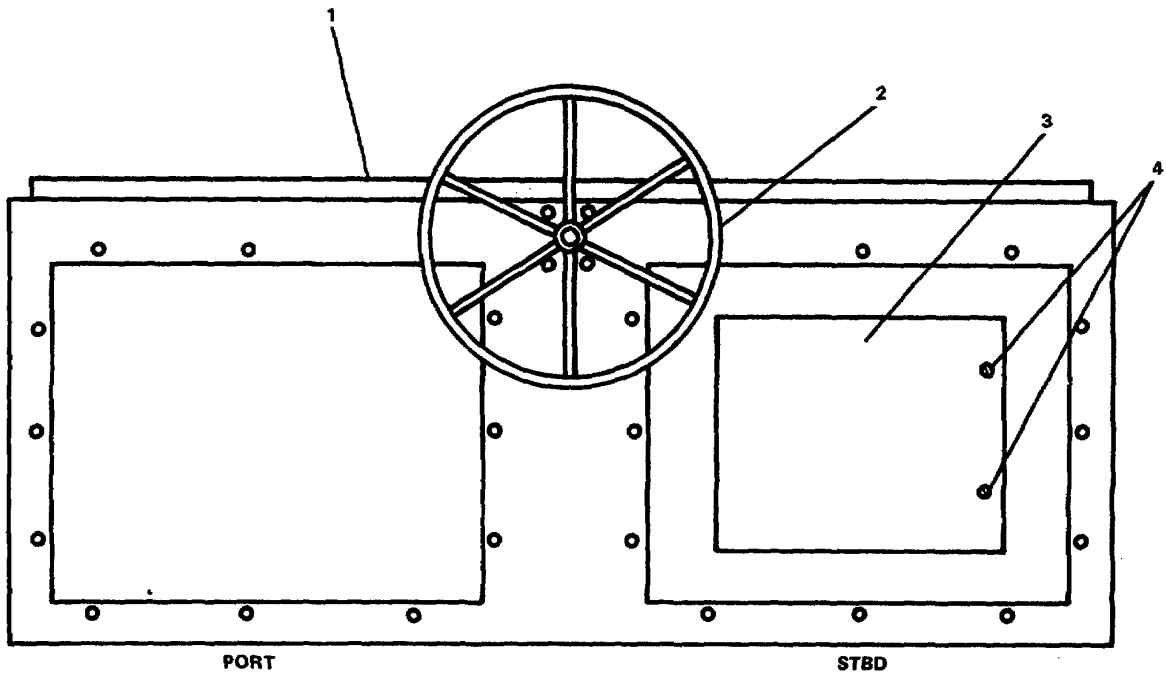

FIGURE 3-99. Pilothouse Control Console.

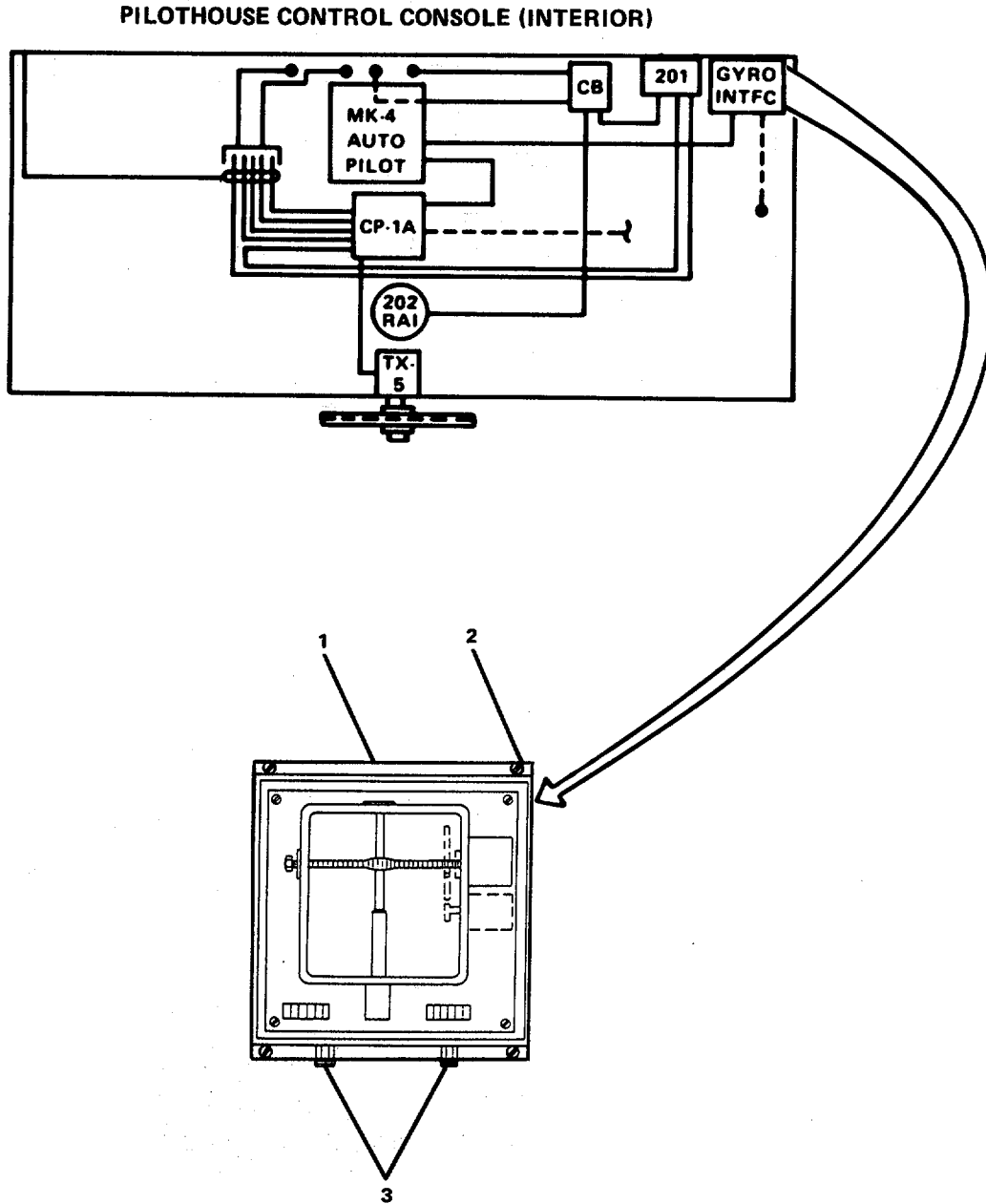
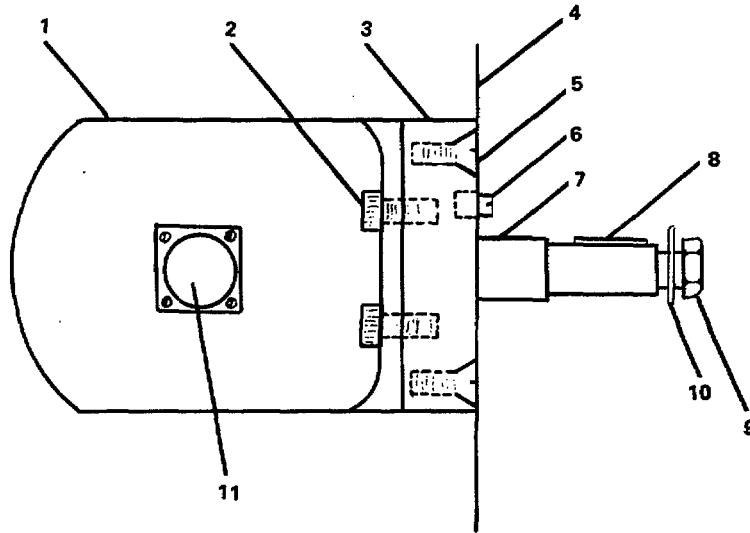
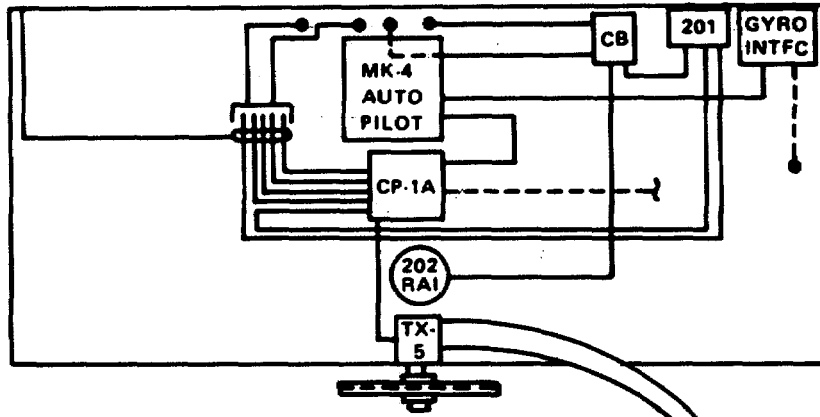

FIGURE 3-100. Gyro Interface Assembly.

PILOTHOUSE CONTROL CONSOLE (INTERIOR)



WHEEL CONTROLLER (SIDE VIEW)

FIGURE 3-101. *Wheel Controller, Helm Unit.*

- (3) Remove four countersunk screws (5) securing front plate (3) and wheel controller (1) to control console (4).
- (4) Remove wheel controller and front plate from interior of control console.
- (5) Remove four capscrews (2) securing wheel controller to front plate.

## REPAIR

Repair at this level of maintenance is by replacement of gyro interface assembly (1, Figure 3-100) and helm unit wheel controller (1, Figure 3-101).

## REPLACEMENT

### a. Replace Wheel Controller. Helm Unit.

- (1) Position wheel controller (1, Figure 3-101) on front plate (3) and secure with four capscrews (2).
- (2) Position wheel controller and front plate in control console (4). Make sure setscrew (6) goes into the proper hole.
- (3) Secure wheel controller, helm unit to control console (4) with four countersunk screws (5).
- (4) Install shaft key (8).
- (5) Slide wheel (2, Figure 3-99) over shaft key and shaft.
- (6) Secure with capscrew (9, Figure 3-101) and washer (10).

### b. Replace Gyro Interface Assembly.

- (1) Position gyro interface assembly (1, Figure 3-100) on starboard side (interior) of pilothouse control console.
- (2) Secure assembly to rear of control console with four capscrews (2).
- (3) Connect electrical wiring to cable fittings (3) and remove tags.
- (4) Replace access panel (3, Figure 3-99) and secure to pilothouse control console (1) with two latching screws (4).
- (5) Restore electrical power to control console and remove warning tags.

---

**3-116. Replace/Repair Steering Control Panel Assembly. (Figure 3-102)**

---

**This task covers:**    **a. Removal,**    **b. Disassembly,**    **c. Repair,**    **d. Assembly,**  
                                  **e. Replacement.**

---

**INITIAL SETUP**

Tools

Tool kit, electrician's,  
 5180-00-391-1087

Equipment Condition

Power to steering control panel secured  
 and tagged "Out of Service - Do Not  
 Operate." (TM 55-1905-223-10)

Materials/Parts

Steering control panel assembly  
 P/N CP-1  
 Push switch (2) P/N 210-071  
 Light lens P/N 411-022  
 Incandescent lamp (4) P/N 410-035  
 Dust and moisture boot seal (4)  
 P/N 211-006  
 Rotary switch P/N 200-040  
 Rudder order indicator P/N 510-132  
 Variable nonwire wound, nonprecision  
 resistor P/N 125-024  
 Push switch (2) P/N 210-062  
 Light lens (2) P/N 210-070  
 Knob P/N 620-024  
 Light lens P/N 411-023  
 Push switch P/N 480-017  
 Printed circuit board (LED display)  
 P/N 505-344  
 Printed circuit board (alarm logic)  
 P/N 505-343  
 Voltage regulator P/N 315-011  
 Voltage regulator P/N 315-008  
 Warning tags, Item 1, Appendix C

---

**REMOVAL**

- a. Remove eight round head screws (2) securing panel assembly (1) to pilothouse control console.
- b. Lift panel assembly up and out of console until electrical leads are accessible.
- c. Tag and disconnect electrical leads to the following rudder order indicator (3), push switches (7, 9, 13, and 23), rotary switches (16, 26), nonwire wound, nonprecision variable resistor (19), and voltage regulator (38).



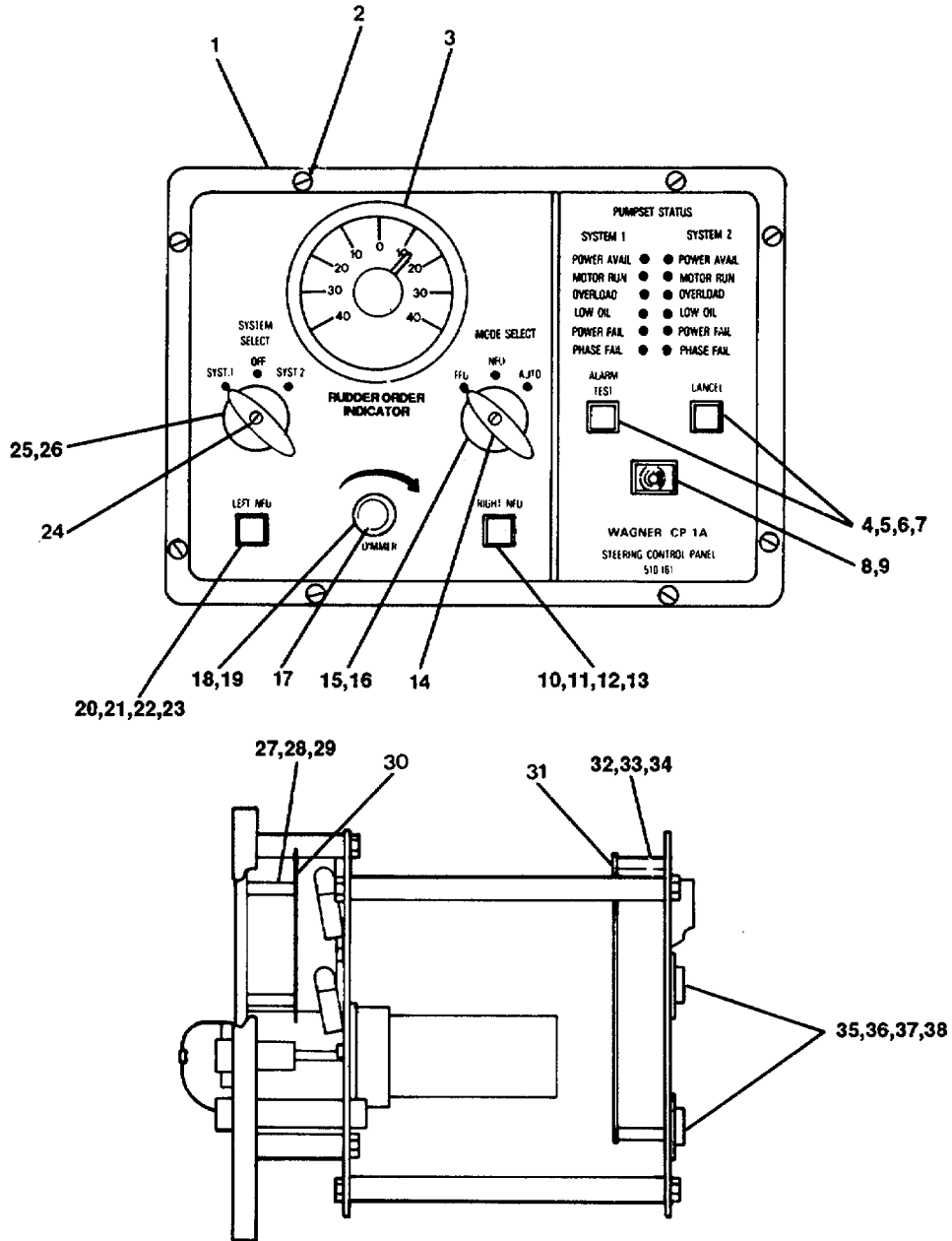

FIGURE 3-102. *Steering Control Panel Assembly.*

- d. Remove panel assembly (1).

#### DISASSEMBLY

- a. Remove mounting hardware and remove rudder order indicator (3).
- b. Remove light lens (white) (4), dust and moisture seal boot (5), incandescent lamp (6), and push switches (7).
- c. Remove audible alarm cover (8) and push switch (9).
- d. Remove light lens (green) (10), dust and moisture seal boot (11), incandescent lamp (12), and push switch (13).
- e. Remove retaining screw (14), knob (15), and rotary switch (16).
- f. Remove setscrew (17), knob (18), and variable resistor (19).
- g. Remove light lens (red) (20), dust and moisture seal boot (21), incandescent lamp (22), and push switch (23).
- h. Remove retaining screw (24), knob (25), and rotary switch (26).
- i. Remove machine screw (27), lockwasher (28), and spacer (29).
- j. Remove printed circuit board (LED display) (30).
- k. Remove machine screw (32), lockwasher (33), and spacer (34).
- l. Remove printed circuit board (alarm logic) (31).
- m. Remove self-tapping screw (35), insulator (36), and socket (37).
- n. Remove voltage regulators (38).

#### REPAIR

Repair at this level of maintenance is by replacement of light lenses (4, 10, and 20), dust and moisture boot seals (5, 11, and 21), incandescent lamps (6, 12, and 22), push switches (7, 19, 13, and 23), rudder order indicator (3), knobs (15, 18, and 25), rotary switches (16, 26), variable resistor (19), printed circuit boards (30, 31), and voltage regulator (38).

#### ASSEMBLY

- a. Install sockets (37), insulators (36), and voltage regulator (38).
- b. Secure with self-tapping screws (35).
- c. Install spacer (34) and printed circuit board (alarm logic) (31).
- d. Secure with machine screws (32) and lockwashers (33).

- e. Install spacer (29) and printed circuit board (LED display) (30).
- f. Secure with machine screws (27) and lockwashers (28).
- g. Install rotary switch (26) and knob (25).
- h. Secure knob with retaining screw (24).
- i. Install push switch (23), incandescent lamp (22), dust and moisture boot seal (21), and light lens (red) (20).
- j. Install variable resistor (19) and knob (18); secure knob with setscrew (17).
- k. Install rotary switch (16) and knob (15); secure knob with retaining screw (14).
- l. Install push switch (13), incandescent lamp (12), dust and moisture boot seal (11), and light lens (green) (10).
- m. Install push switch (9) and audible alarm cover (8).
- n. Install push switches (7), incandescent lamps (6), dust and moisture boot seals (5), and light lenses (white) (4).
- o. Install rudder order indicator (3) and secure with mounting hardware.

## REPLACEMENT

- a. Connect electrical leads to the following voltage regulator (38), variable resistor (19), rotary switches (16,26), push switches (7,9, 13, and 23), and rudder order indicator (3).
- b. Remove tags.
- c. Install steering control panel assembly (1) in pilothouse control console.
- d. Secure with eight round head screws (2).
- e. Restore electrical power to steering control panel assembly and remove tags.



---

**3.116.1. Replace/Repair Steering Control Panel (Figure 3-102.1)**

---

**This task covers:**      **a. Removal,**                      **b. Disassembly,**                      **c. Repair,**  
    **d. Assembly,**                      **e. Replacement**

---

**INITIAL SETUP**Tools

Tool kit, electricians  
5180-00-392-2895

Equipment Condition

Power to steering control panel secured and tagged "Out of Service – Do Not Operate"  
(TM 55-1905-223-10)

Materials/Parts

Steering control panel, P/N 9999-40710  
 Printed circuit board, P/N 9999-40720  
 Transistor & heat sink unit, P/N 9999-40790  
 Diode, P/N IN4001  
 Steering control P.C.B., P/N 9999-21609  
 Knob, P/N 515D  
 Potentiometer, P/N 53C35K  
 Pushbutton switch, P/N 7040102R  
 Pushbutton switch, P/N 7040102G  
 Contact block, P/N 704-9005 (2)  
 Rotary switch, P/N 21310A  
 Rotary switch, P/N 21308A  
 1 ¾ R Rudder order meter, P/N 71111R-24V  
 Pushbutton switch, P/N 82610  
 Indicator light, P/N 386L (6)  
 Warning tags, Item 1, Appendix C

---

**REMOVAL**

- a. Remove four screws (4) securing panel (3) to pilothouse control console.
- b. Lift panel up and out of console until electrical leads are accessible.
- c. Tag and disconnect leads to the rudder order meter (10), Pushbutton switches (9, 11, and 13), rotary switches (8, 17), and potentiometer (15).

**DISASSEMBLY**

- a. Remove mounting hardware and remove rudder order meter (10).
- b. Remove lamps (5).
- c. Remove knob (7), mounting screws (6) and the eight layer rotary switch (8).
- d. Remove pushbutton switch (9).

- e. Remove pushbutton switch (11) and contact block (12).
- f. Remove pushbutton switch (13) and contact block (12).
- g. Remove dimmer knob (14) and potentiometer (15).
- h. Remove knob (16) mounting screws (18) and the ten layer rotary switch (17).
- i. Remove and tag wires from terminal board TB3 (1) and remove steering control P.C.B. (2).
- j. Remove three screws (22) and lockwashers (21) and remove rudder order P.C.B. (20).
- k. Remove transistor and heat sink unit (23).
- l. Remove diode (19).

### REPAIR

Repair at this level of maintenance is by replacement of: steering control P.C.B. (2), lamps (5), rotary switches (8, 17), pushbutton switches (9, 11 and 13), rudder order meter (10), knob (14), potentiometer (15), rudder order P.C.B. (20), transistor and heat sink unit (23) and diode (19).

### ASSEMBLY

- a. Install diode (19).
- b. Install transistor and heat sink unit (23).
- c. Install rudder order P.C.B. (20) and secure with three screws (22) and lockwashers (21).
- d. Install steering control P.C. B. (2).
- e. Install ten layer rotary switch (17), knob (16) and secure with mounting screws (18).
- f. Install potentiometer (15) and dimmer knob (14).
- g. Install contact block (12) and pushbutton switch (13).
- h. Install contact block (12) and pushbutton switch (11).
- i. Install pushbutton switch (9).
- j. Install eight layer rotary switch (8), knob (7) and secure with mounting screws (6).
- k. Install lamps (5).
- l. Install rudder order meter (10) and mounting hardware.

### REPLACEMENT

- a. Connect electrical leads to the potentiometer (15), rotary switches (8, 17), pushbutton switches (9, 11 and 13) and rudder order meter (10) and remove tags.
- b. Install steering control panel (3) in pilothouse control console.
- c. Secure with four screws (4).
- d. Restore electrical power to steering control panel assembly and remove tags.

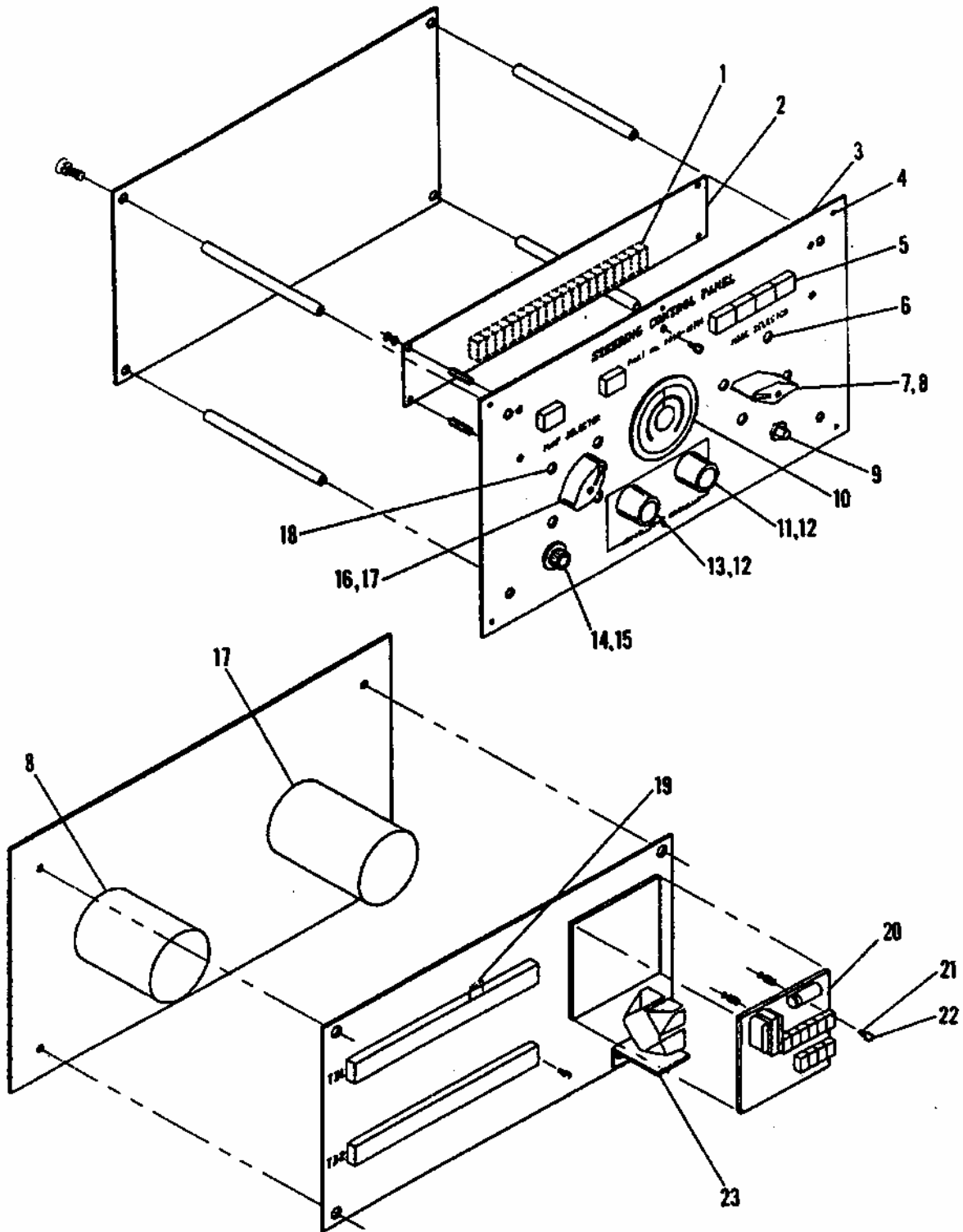

Figure 3-102.1 Steering Control Panel.

---

3-117. Replace/Repair Autopilot Control Assembly.

---

**This task covers:**      **a. Removal,**                      **b. Repair,**                      **c. Replacement**

---

**INITIAL SETUP**

Tools

Tool kit, general mechanic's,  
5180-00-699-5273

Equipment Condition

Electrical power to autopilot  
OFF and tagged "Out of Service -  
Do Not Operate,"

Materials/Parts

Autopilot control assembly  
PIN Mk 4  
Warning tags, Item 1, Appendix C

---

**REMOVAL**

- a. Loosen two latching screws (3, Figure 3-103) securing starboard side access panel (2) to pilothouse control console (1).
- b. Remove cover plate.
- c. Tag and disconnect cables at fittings (3, 4, Figure 3-104).
- d. Remove four round head screws (2).
- e. Remove autopilot assembly (1).

**REPAIR**

Repair at this level of maintenance is by replacement of autopilot control assembly (1).

**REPLACEMENT**

- a. Install autopilot assembly (1) into control console and secure with four round head screws (2).
- b. Connect cables to fittings (3, 4) and remove tags,
- c. Close access panel (2, Figure 3-103) on control console (1) and secure with two latching screws (3).
- d. Restore power to pilothouse control console and remove warnings tags.



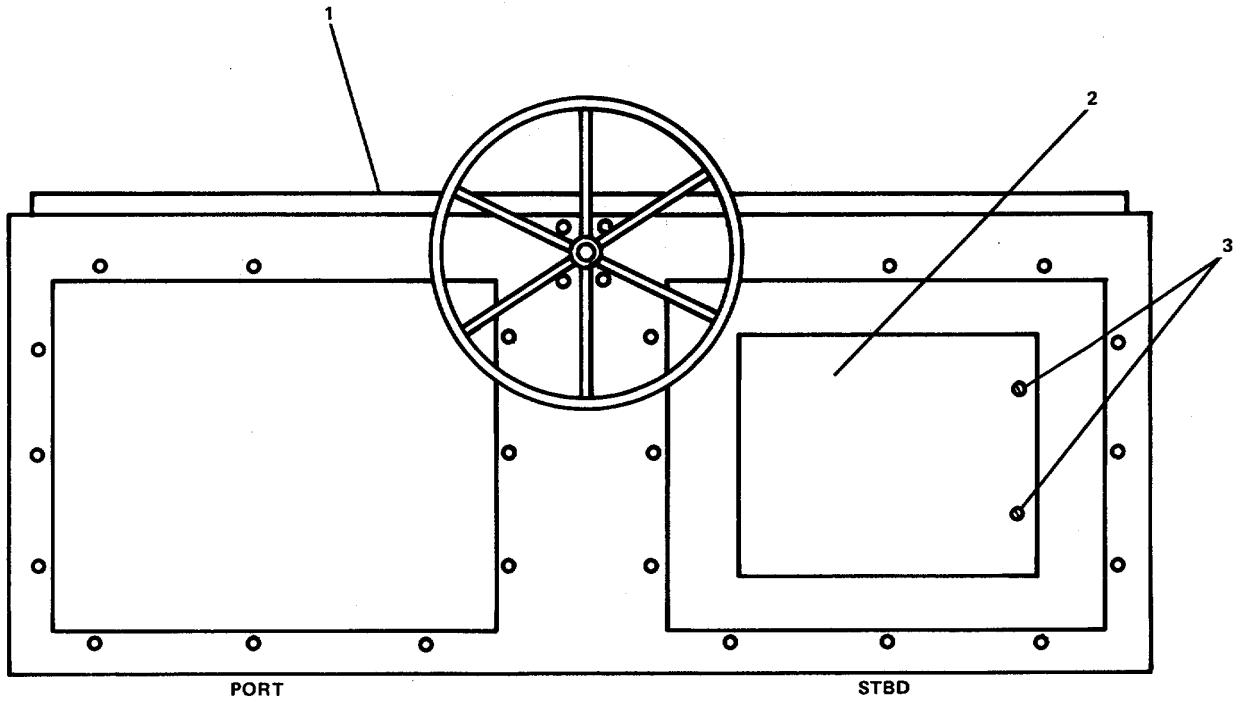

FIGURE 3-103. *Pilothouse Control Console.*

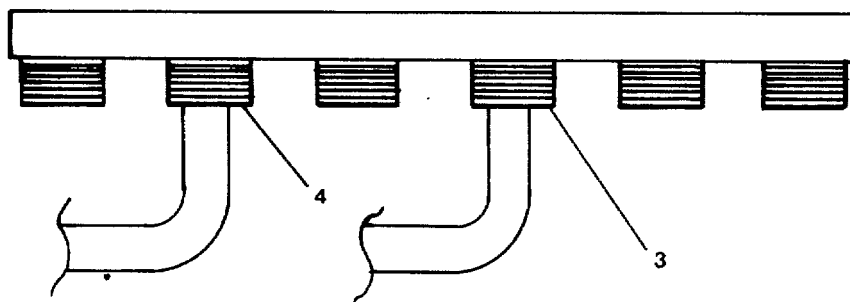
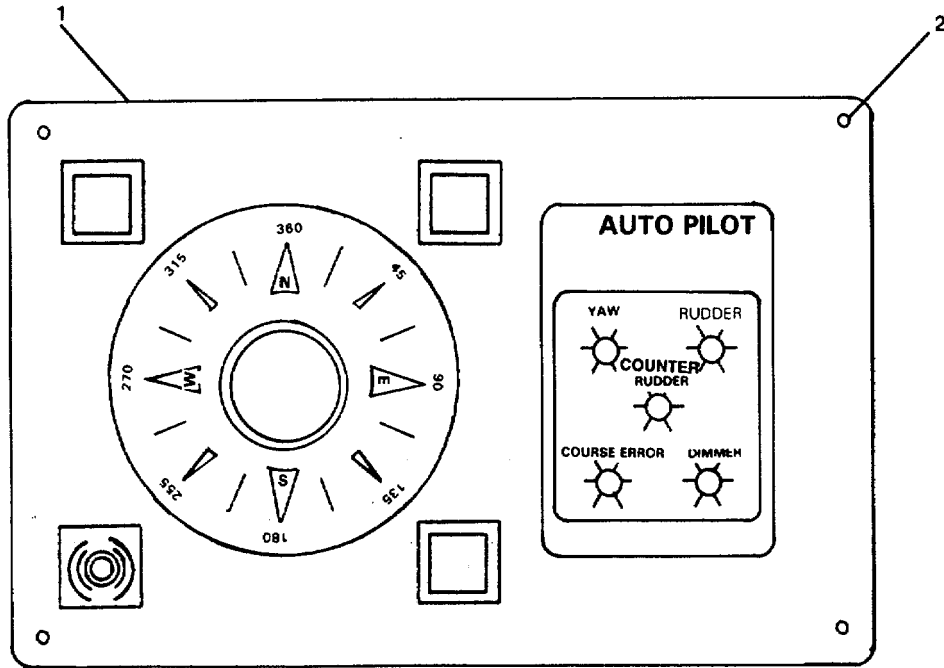

FIGURE 3-104. *Replace Autopilot Assembly.*

**3-117.1. Replace/Repair Autopilot Panel Assembly (Figure 3-104.1)**

**This task covers:**      **a. Removal,**                      **b. Disassembly,**                      **c. Repair,**  
    **d. Assembly,**                      **e. Replacement**

**INITIAL SETUP**Tools

Tool kit, general mechanic's  
5180-00-392-2895

Equipment Condition

Electrical power to autopilot  
OFF and tagged "Out of Service –  
Do Not Operate."  
(TM 55-1905-223-10)

Materials/Parts

Autopilot panel assembly, P/N 9999-40740  
Autopilot P.C.B., P/N 9999-40700  
Relay, P/N Z120D10  
Potentiometer 10K, P/N 70TAN056P103UF (4)  
Potentiometer 250 ohm, P/N 70TAN056P202UF  
Potentiometer 750 ohm, P/N 53C750 (2)  
Potentiometer 2K, P/N 70TAN056P202UF  
Heading changer, P/N HC404  
Indicator lamp, P/N 1819  
L.E.D. Red, P/N L58D-R2-W  
L.E.D. Green, P/N L58D-G2-W  
Toggle switch, P/N 7101  
Warning tags, Item 1, Appendix C

**REMOVAL**

- a. Loosen two latching screws (3, Figure 3-103) securing starboard side access panel (2) to pilothouse control console (1).
- b. Open access panel.
- c. Tag and disconnect wiring from autopilot unit.
- d. Remove four screws (1) from front panel (2).
- e. Remove autopilot unit.

**DISASSEMBLY**

- a. Remove potentiometers (3, 4 and 5).
- b. Remove the two relays (6).
- c. Remove the green L.E.D. (8) and the red L.E.D. (7).
- d. Remove the knob and potentiometer (9).
- e. Remove the knob and potentiometer (10).
- f. Remove the knob and potentiometer (11).
- g. Remove the knob and potentiometer (12).
- h. Remove toggle switch (13).

- i. Remove the knob and potentiometer (14).
- j. Remove knob (15).
- k. Remove bulb from indicator (16).
- l. Remove resistor pack bracket (18).
- m. Remove heading changer (17).
- n. Remove autopilot P.C.B. (19).

**REPAIR**

Repair at this level of maintenance is by replacement of potentiometers (3, 4, 5, 9, 10, 11, 12, and 14), L.E.D.'s (7, 8), toggle switch (13), knob (15), resistor pack (18), heading changer (17) and autopilot P.C.B. (19).

**ASSEMBLY**

- a. Install autopilot P.C.B. (19).
- b. Install heading changer (17).
- c. Install resistor pack bracket (18).
- d. Install bulb in indicator (16).
- e. Install knob (15).
- f. Install potentiometer (14) and knob.
- g. Install toggle switch (13).
- h. Install potentiometer (12) and knob.
- i. Install potentiometer (11) and knob.
- j. Install potentiometer (10) and knob.
- l. Install the red L.E.D. (7) and green L.E.D. (8).
- m. Install the two relays (6).
- n. Install potentiometers (3, 4, and 5).

**REPLACEMENT**

- a. Install autopilot unit in control console.
- b. Secure with four screws (1).
- c. Connect wiring to autopilot and remove tags.
- d. Close access panel (2, Figure 3-104.1).
- e. Fasten two latching screws (3, Figure 3-104.1) securing access panel (2, Figure 3-104.1) to pilothouse control console (1, Figure 3-104.1).

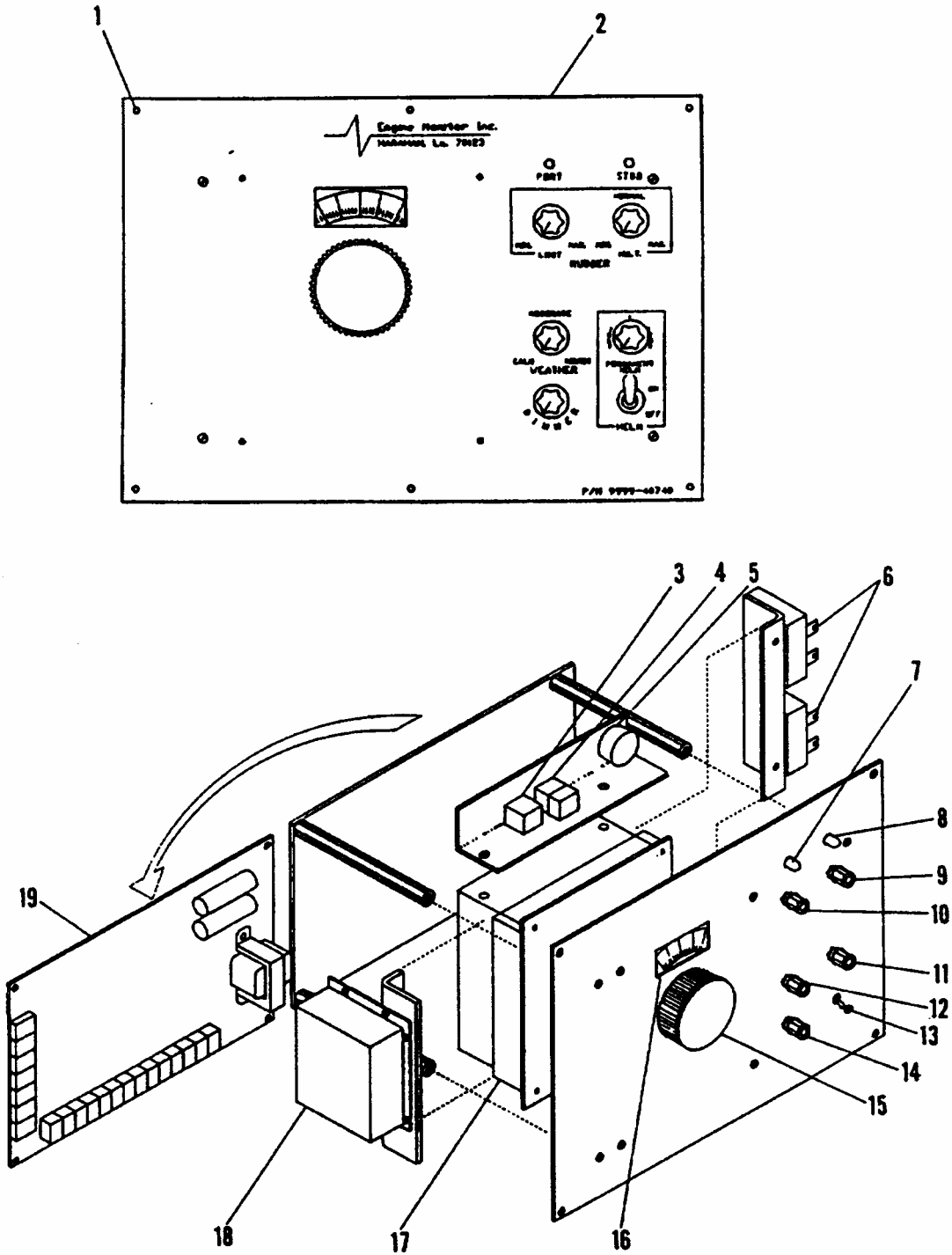

Figure 3-104.1. Autopilot Unit



---

### 3-118. Replace/Repair Rudder Indicator.

---

**This task covers:**

- |                       |                    |
|-----------------------|--------------------|
| <b>a. Removal</b>     | <b>c. Repair</b>   |
| <b>b. Disassembly</b> | <b>d. Assembly</b> |
- 

#### INITIAL SETUP

##### Tools

Tool kit, electrician's,  
5180-00-391-1087

##### Equipment Condition

Electrical power to steering control  
and autopilot system OFF and tagged  
'Out of Service - Do Not Operate.'  
(TM 55-1905-223-10)

##### Materials/Parts

Cartridge fuse P/N 420-001  
Printed circuit board  
P/N 130-024  
Warning tags, Item 1, Appendix C  
Indicator assembly repair kit  
P/N 740-026

---

#### REMOVAL

- a. Loosen two latching screws (3, Figure 3-105) securing starboard side access panel ,(2) to pilothouse control console (1).
- b. Remove cover plate.
- c. Tag and disconnect cable at fitting (8, Figure 3-106).
- d. Remove four round head screws (9).
- e. Remove rudder indicator (1).

#### DISASSEMBLY

- a. Remove capscrews (5) and lockwasher (4) securing printed circuit board (2) to back plate (7) of rudder indicator (1).
- b. Remove fuse (3).
- c. Remove printed circuit board (2). Replace if required.

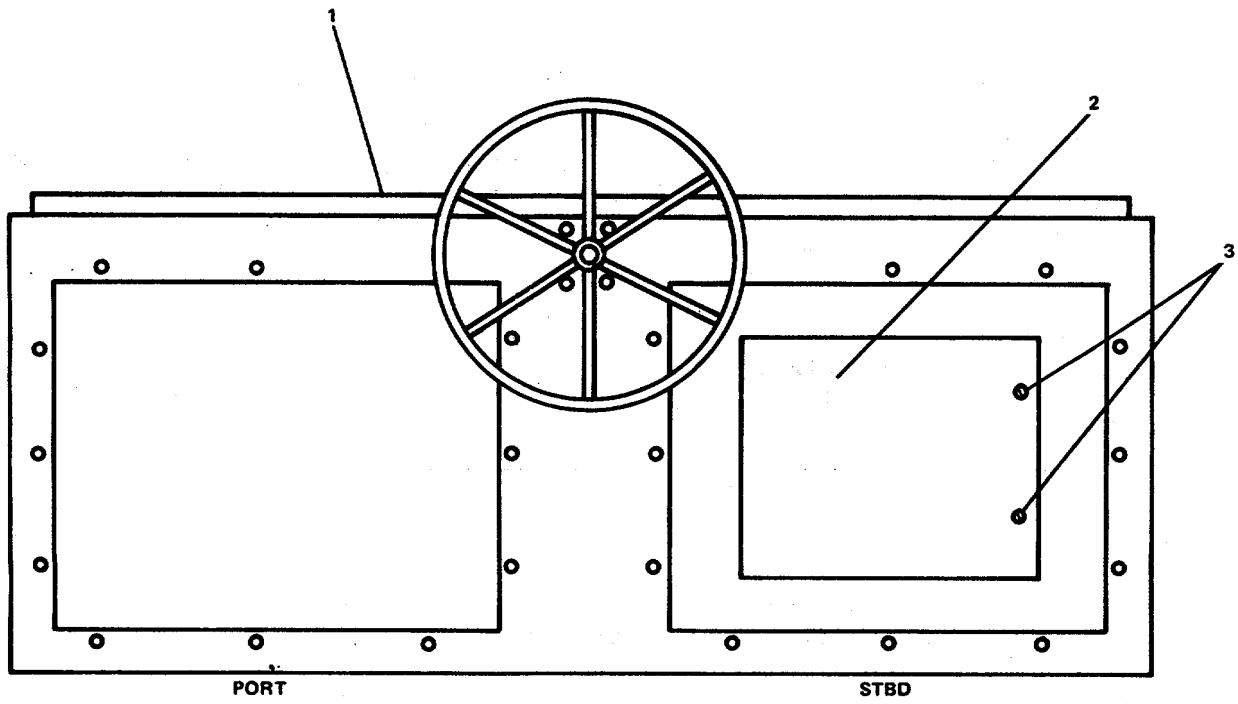

FIGURE 3-105. Pilothouse Control Console.



PILOTHOUSE CONTROL CONSOLE (INTERIOR)

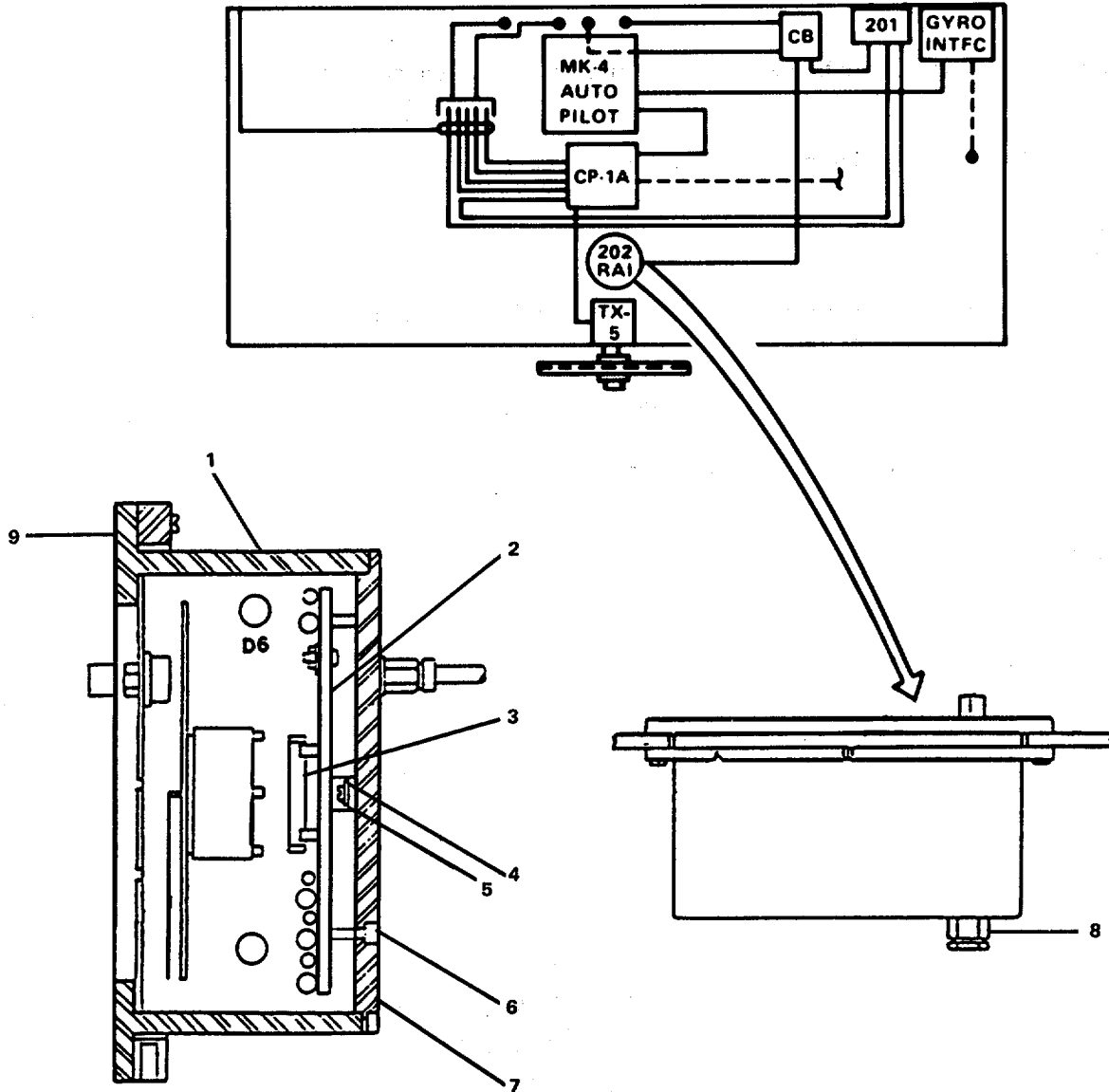

FIGURE 3-106. Repair Rudder Indicator.

REPAIR

Repair at this level of maintenance is by replacement of printed circuit boards (2) and fuses (3).

ASSEMBLY

- a. Secure circuit boards (2) to back plate (7) with capscrews (5, 6) and lockwasher (4).
- b. Install fuse (3) in new printed circuit board.

REPLACEMENT

- a. Install rudder indicator (1, Figure 2-106) into control console and secure with four round head screws (9).
- b. Connect cable to fitting (8) and remove tags.
- c. Close access panel (2, Figure 3-105) on control console (1) and secure with two latching screws (3).
- d. Restore power to pilothouse control console and remove warnings tags.

---

**3-118.1. Replace/Repair Rudder Indicator (Figure 3-106.1)**

---

<b>This task covers:</b>	<b>a. Removal d. Assembly</b>	<b>b. Disassembly e. Replacement</b>	<b>c. Repair</b>
--------------------------	-----------------------------------	--	------------------

---

**INITIAL SETUP**Tools

Tool kit, electrician's  
5180-00-392-2895

Equipment Condition

Electrical power to steering  
control and autopilot system  
OFF and tagged "Out of Service –  
Do Not Operate."  
(TM 55-1905-223-10)

Materials/Parts

Rudder indicator, P/N 9999-40890  
Potentiometer, P/N D53C-750  
Meter assembly, P/N 9999-40840  
Printed circuit board, P/N 9999-20200  
Warning tags, Item 1, Appendix C

---

**REMOVAL**

- a. Loosen two latching screws (3, Figure 3-106.1) securing starboard side access panel (2, Figure 3-106.1) to pilothouse control console (1, Figure 3-106.1).
- b. Open access panel.
- c. Tag and disconnect wiring from rudder indicator.
- d. Remove four screws (6).
- e. Remove rudder indicator (2).

**DISASSEMBLY**

- a. Remove printed circuit board (1).
- b. Remove knob (4) and potentiometer (5).
- c. Remove meter assembly (3).

**REPAIR**

Repair at this level of maintenance is by replacement of: printed circuit board (1), meter assembly (3) and potentiometer (5).

**ASSEMBLY**

- a. Install meter assembly (3).
- b. Install potentiometer (5) and knob (4).
- c. Install printed circuit board (1).

**REPLACEMENT**

- a. Install rudder indicator (2) into control console.
- b. Secure with four screws (6).
- c. connect wiring to rudder indicator (2) and remove tags.
- d. Close access panel (2, Figure 3-106.1) on control console (1, Figure 3-106.1) and secure with two latching screws (3, Figure 3-106.1).
- e. Restore power to pilothouse control console and remove warning tags.

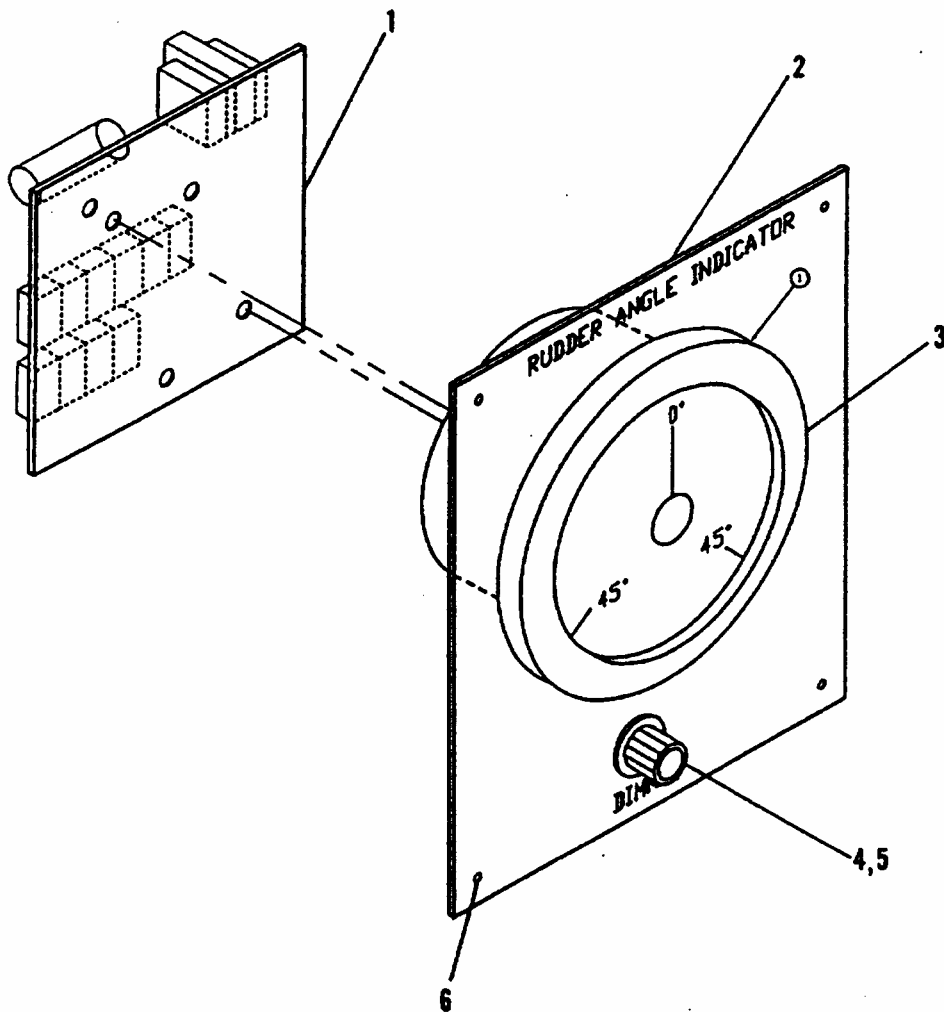

Figure 3-106.1. Rudder Indicator

---

### 3-119. Replace/Repair Junction Box Assembly. (Figure 3-107)

---

**This task covers:**

- |             |                |           |
|-------------|----------------|-----------|
| a. Removal  | b. Disassembly | c. Repair |
| d. Assembly | e. Replacement |           |
- 

#### INITIAL SETUP

##### Tools

Tool kit, electrician's,  
5180-00-391-1087

##### Materials/Parts

Printed circuit board  
P/N 505-030  
Junction box repair kit  
P/N 740-027  
Warning tags, Item 1, Appendix C

##### Equipment Condition

Electrical power to pilothouse control  
console OFF and tagged "Out of  
Service - Do Not Operate."  
Access panel on control console  
opened, para. 3-115 .

---

#### REMOVAL

- a. Unfasten door latches (3) on right side of junction box (1). Swing door (5) to the left to open.
- b. Tag and disconnect electrical wires (4) from terminal board (6).
- c. Remove four mounting screws (2).
- d. Remove junction box assembly (1).

#### DISASSEMBLY

- a. Remove four hex head screws (7) from each corner of printed circuit board (8).
- b. Remove printed circuit board.

#### REPAIR

Repair at this level of maintenance is by replacement of printed circuit board (8).

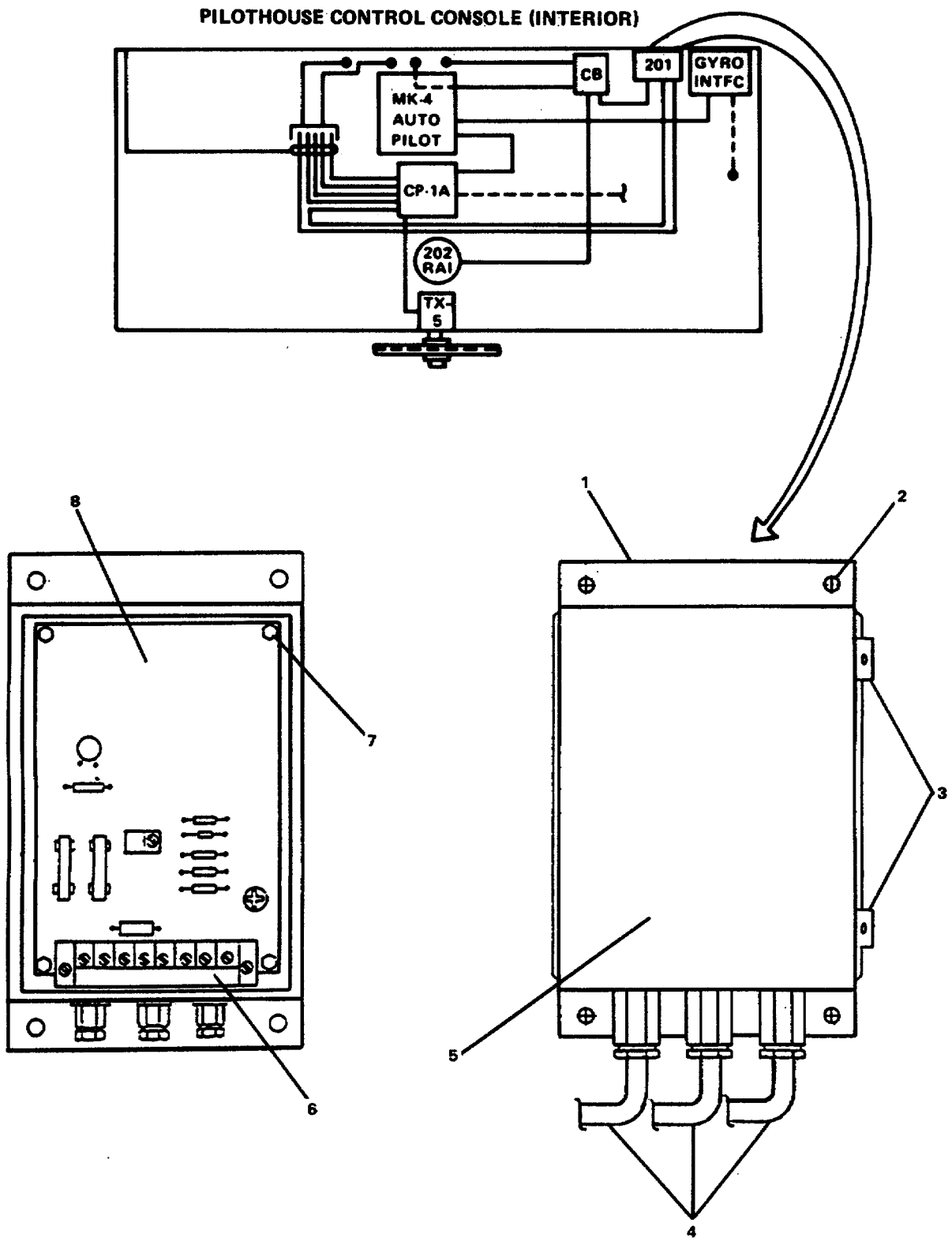

FIGURE 3-107. Junction Box Assembly.

ASSEMBLY

- a. Install printed circuit board (8) in junction box assembly (1).
- b. Secure with four hex head screws (7).

REPLACEMENT

- a. Install junction box assembly (1) in back of pilothouse control console.
- b. Secure with four mounting screws (2).
- c. Connect electrical wires (4) to terminal board (6). Remove tags.
- d. Close door and secure door latches (3).
- e. Close access panel on control console, para. 3-115 .
- f. Restore electrical power to pilothouse control console; remove tags.

---

**3-120. Replace/Repair Isolation Control Unit. (Figure 3-108)**

---

**This task covers:****a. Inspection****b. Repair****c. Replacement**

---

**INITIAL SETUP**Tools

Tool kit, general mechanic's,  
5180-00-699-5273

Equipment Condition

Electrical power to emergency steering  
control units secured and tagged "Out  
of Service - Do Not Operate."  
TM 55-1905-223-10

Materials/Parts

Warning tags, Item 1, Appendix C

---

REMOVAL

- a. Loosen two latch (3) screws (2).
- b. Swing door (7) to the left to open.
- c. Tag and disconnect electrical power cables (5) from terminal board (4). Remove cables from control unit.
- d. Remove four hex head bolts (6).
- e. Remove isolation control unit (1) from bulkhead.

REPAIR

Repair at this level of maintenance is by replacement of isolation control unit (1).

REPLACEMENT

- a. Position isolation control unit (1) on bulkhead.
- b. Secure with four hex head bolts (6).
- c. Install electrical power cables (5) in isolation control unit.
- d. Connect cables to terminal board (4). Remove tags.
- e. Close door (7).
- f. Secure door with latches (3) and screws (2).



- g. Restore electrical power to isolation control unit and remove tags.

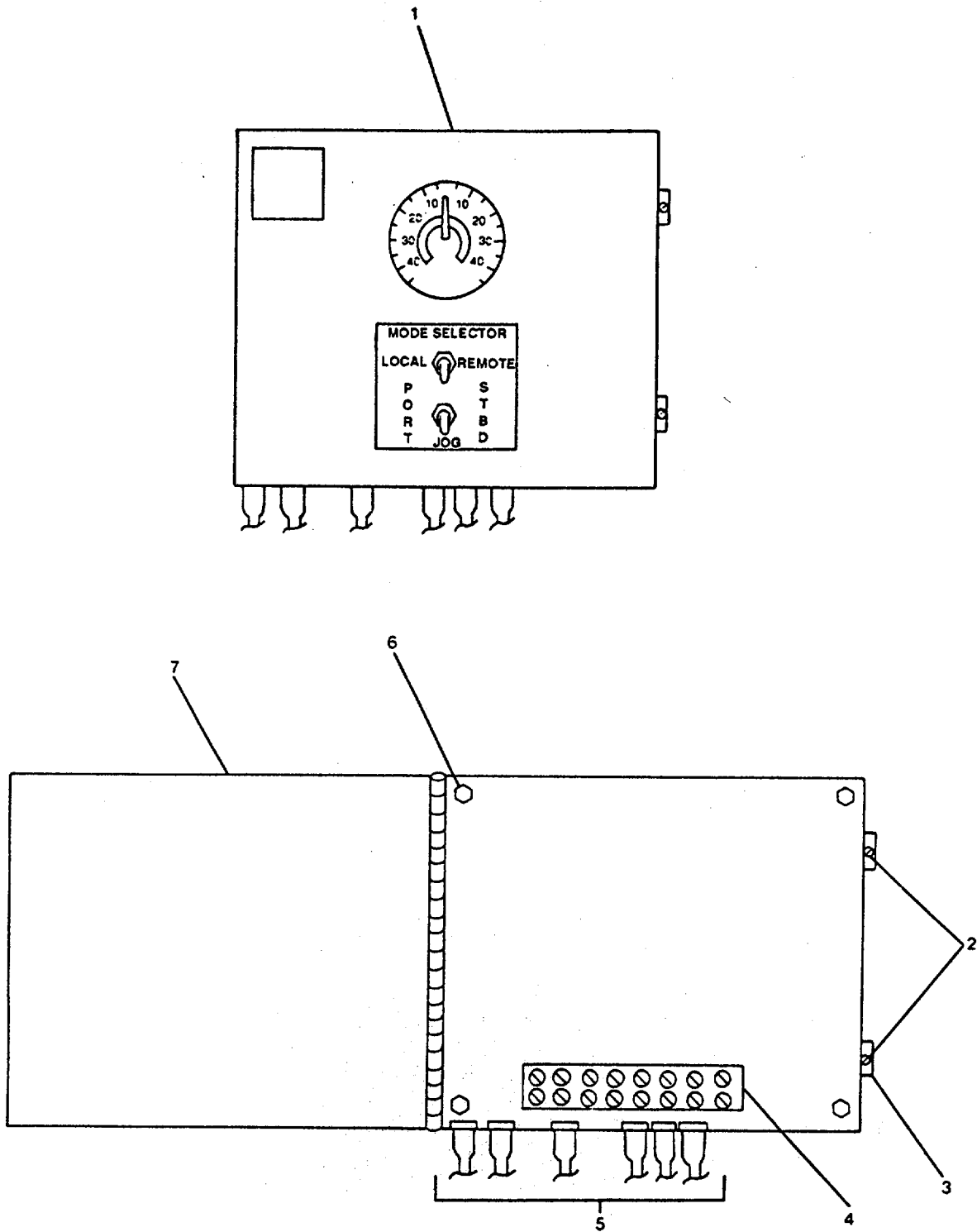

FIGURE 3-108. *Isolation Control Unit.*

**3-121. Replace/Repair Machinery Plant Monitoring and Alarm System.****This task covers:****a. Removal****b. Repair****c. Replacement**INITIAL SETUPTools

Tool kit, electrician's,  
5180-00-391-1087

Materials/Parts

Machinery plant monitoring and alarm  
system P/N 01-10200-000  
Warning tags, Item 1, Appendix C

Equipment Condition

Power to machinery plant monitoring and  
alarm system secured and tagged "Out  
of Service - Do Not Operate."  
(TM 55-1905-223-10)

REMOVAL

- a. Remove engine room panel assembly (para. 3-122).
- b. Remove engine room multi-remote module (para. 3-123).
- c. Remove port engine remote module (para. 3-124).
- d. Remove annunciators (engineer's quarters and galley) (para. 3-125).
- e. Remove starboard engine remote module (para. 3-126).
- f. Remove bridge panel assembly (para. 3-127).
- g. Remove central processing unit (para. 3-128).
- h. Remove analog remote module assembly (para. 3-129).
- i. Remove generators remote module (para. 3-130).
- j. Remove interface unit assemblies (para. 3-131).
- k. Remove motor controllers multi-remote module (para. 3-132).

REPAIR

Repair of machinery plant monitoring and alarm system is by replacement of defective components.

---

**REPLACEMENT**

- a. Install motor controllers multi-remote module (para. 3-132).
- b. Install interface unit assemblies (para. 3-131).
- c. Install generators remote module (para. 3-130).
- d. Install analog remote module assembly (para. 3-129).
- e. Install central processing unit (para. 3-128).
- f. Install bridge panel assembly (para. 3-127).
- g. Install starboard engine remote module (para. 3-126).
- h. Install annunciators (engineer's quarters and galley) (para. 3-125).
- i. Install port engine remote module (para. 3-124).
- j. Install engine room multi-remote module (para. 3-123).
- k. Install engine room panel assembly (para. 3-122).
- l. Turn power to machinery plant monitoring and alarm system on and remove tags.

---

**3-122. Replace/Repair Engine Room Panel Assembly. (Figure 3-109)**

---

**This task covers:**

**a. Removal**

**b. Repair**

**c. Replacement**

---

INITIAL SETUP

Tools

Tool kit, electrician's,  
5180-00-391-1087

Materials/Parts

Warning tags, Item 1, Appendix C

---

Equipment Condition

Power to machinery plant monitoring and  
alarm system tagged "Out of Service -  
Do Not Operate." (TM 55-1905-223-10)

---

REMOVAL

- a. Remove eight captive screws (2) securing engine room panel assembly (1) to control console.
- b. Carefully lift panel assembly up by handles (3) until electrical leads are accessible.
- c. Tag and disconnect electrical leads to panel assembly.
- d. Remove panel assembly from control console.

---

REPAIR

Repair at this level of maintenance is by replacement of engine room panel assembly.

---

REPLACEMENT

- a. Position panel assembly (1) over slot in control console.
- b. Connect electrical leads to panel assembly. Remove tags.
- c. Install panel assembly in engine room control console.
- d. Secure with eight captive screws (2).
- e. Restore power to engine room panel assembly. Remove tags.
- f. Press POWER ON LAMP TEST to ensure indicators are working.

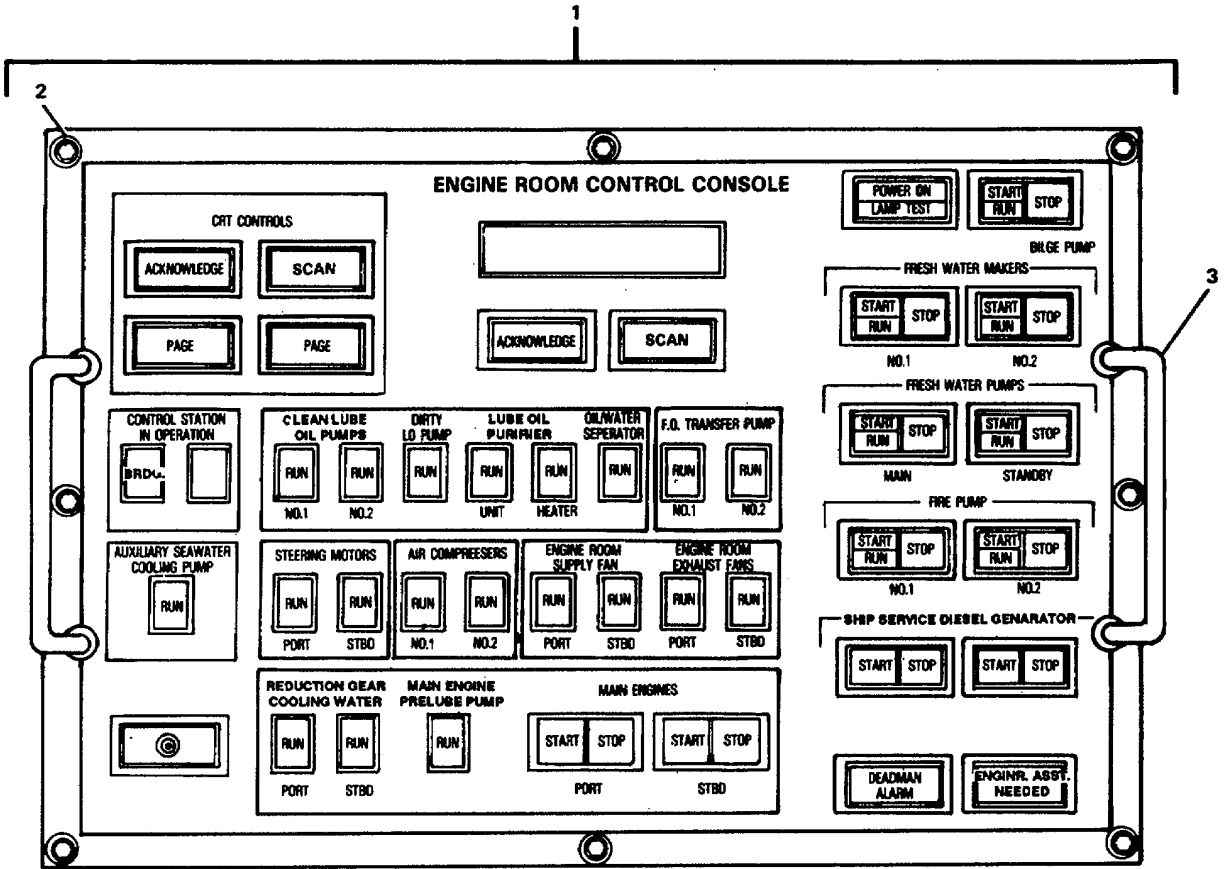

FIGURE 3-109. Engine Room Panel Assembly.

---

**3-123. Replace/Repair Engine Room Multi-Remote Module. (Figure 3-110)**

---

**This task covers:****a. Removal****b. Repair****c. Replacement**

---

INITIAL SETUPTools

Tool kit, electrician's,  
5180-00-391-1087

Materials/Parts

Warning tag, Item 1, Appendix C

Equipment Condition

Electrical power to machinery plant  
monitoring and alarm system secured  
and tagged "Out of Service - Do Not  
Operate." (TM 55-1905-223-10)

---

REMOVAL

- a. Loosen captive screws (1) and open cover (2) on enclosure (3, sheet 1).
- b. Tag and remove electrical leads.
- c. Remove engine room multi-remote module (8, Sheet 2).
- d. Tag and remove electrical power cable (6) from pressure switch (5).
- e. Tag and remove electrical power cable (14) from pressure switch (4).
- f. Tag and remove electrical power cable (12) from pressure switch (13).
- g. Tag and remove electrical power cable (10) from pressure switch (11).
- h. Tag and remove special electrical power cables (7, 9) from P1 and P2.

REPAIR

Repair at this level of maintenance is by replacement of engine room multi-remote module (8) and power cables.

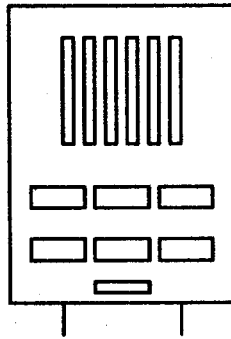
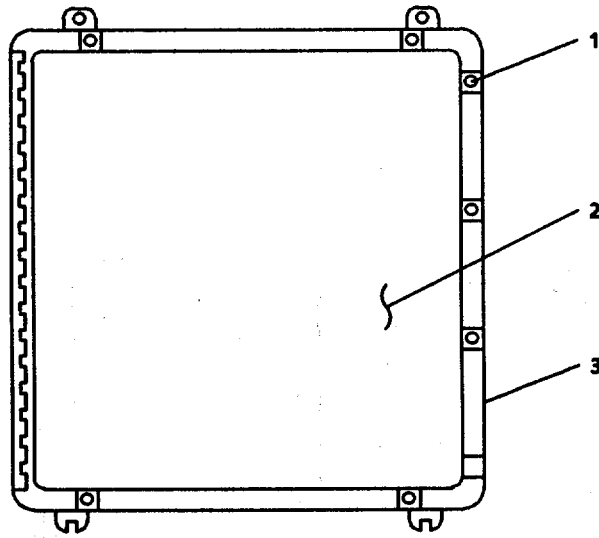

**(MOUNTED INSIDE CONSOLE)**

*FIGURE 3-110. Engine Room Multi-Remote Module (Sheet 1 of 2).*

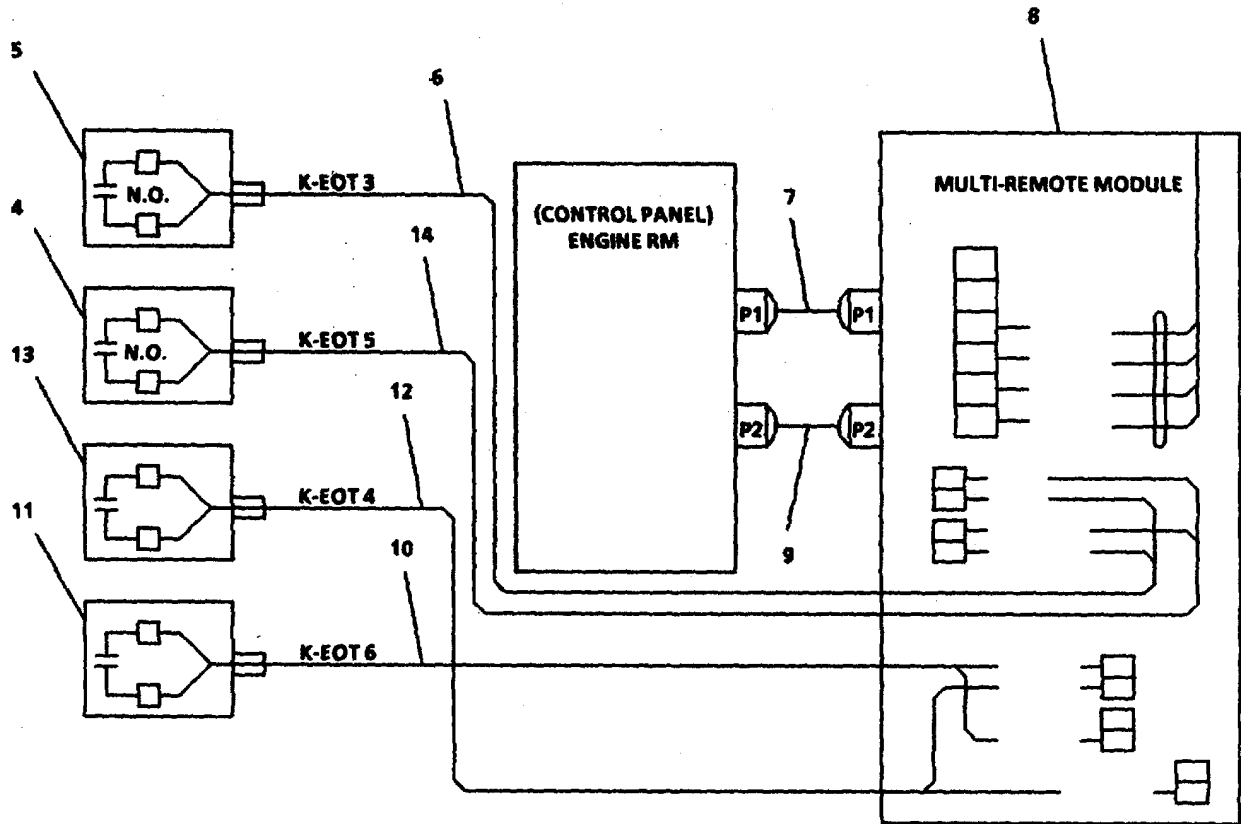

FIGURE 3-110. *Engine Room Multi-Remote Module (Sheet 2 of 2).*



REPLACEMENT

- a. Remove tag and connect special electrical power cables (7, 9) to P1 and P2.
- b. Remove tag and connect electrical power cable (10) to pressure switch (11).
- c. Remove tag and connect electrical power cable (12) to pressure switch (13).
- d. Remove tag and connect electrical power cable (14) to pressure switch (4).
- e. Remove tag and connect electrical power cable (6) to pressure switch (5).
- f. Install engine room multi-remote module (8).
- g. Remove tags and connect leads.
- h. Close cover (2) on enclosure (3) and tighten captive screws (1, Sheet 1).
- i. Remove tag and turn on electrical power to machinery plant monitoring and alarm system.

**3-124. Replace/Repair Port Engine Remote Module. (Figure 3-111)****This task covers:**

- a. Removal**                      **b. Repair**                      **c. Replacement**

INITIAL SETUPTools

Tool kit, electrician's,  
5180-00-391-1087

Equipment Condition

Electrical power to machinery plant  
monitoring and alarm system secured  
and tagged "Out of Service - Do Not  
Operate."

Materials/Parts

Warning Tags, Item 1, Appendix C

REMOVAL

- a. Loosen captive screws (1) and open cover (2) on enclosure (3).
- b. Tag and disconnect electrical leads.
- c. Remove port engine remote module (20).
- d. Tag and disconnect electrical power cable (4) from liquid level switch (5).
- e. Tag and disconnect electrical power cable (6) from solid state switch (7).
- f. Tag and disconnect electrical power cable (8) from liquid level switch (9).
- g. Tag and disconnect electrical power cable (11) from pressure switch (10).
- h. Tag and disconnect electrical power cable (13) from liquid level switch (12).
- i. Tag and disconnect electrical power cable (15) from pressure switch (14).
- j. Tag and disconnect electrical power cables (16, 17, 18, 19).

REPAIR

Repair at this level of maintenance is by replacement of port engine remote module (20) and electrical cables.

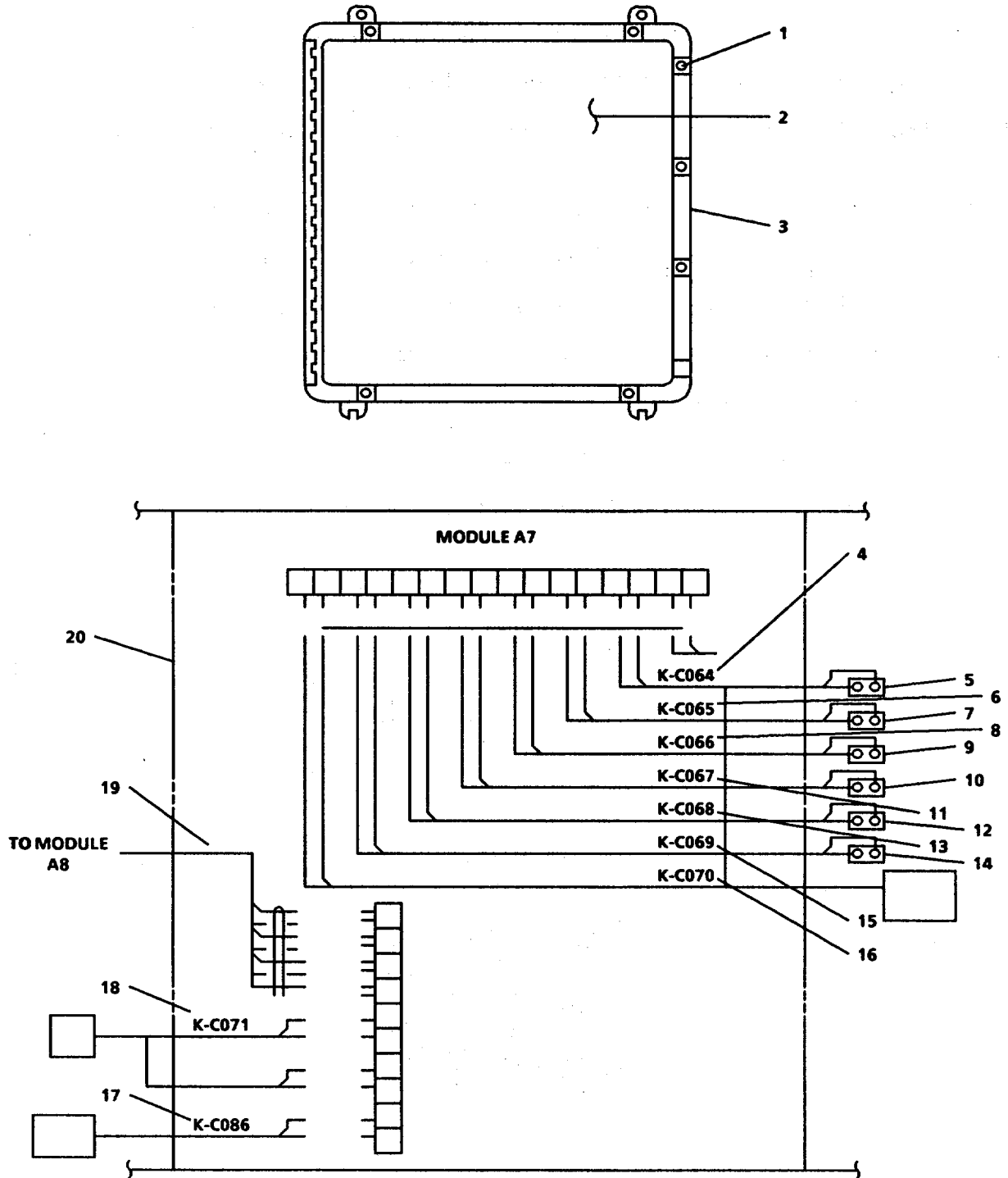

FIGURE 3-111. Port Engine Remote Module.

REPLACEMENT

- a. Remove tags and connect electrical power cables (16, 17, 18, 19).
- b. Remove tag and connect electrical power cable (15) to pressure switch (14).
- c. Remove tag and connect electrical power cable (13) to liquid level switch (12).
- d. Remove tag and connect electrical power cable (11) to pressure switch (10).
- e. Remove tag and connect electrical power cable (8) to liquid level switch (9).
- f. Remove tag and connect electrical power cable (6) to solid state switch (7).
- g. Remove tag and connect electrical power cable (4) to liquid level switch (5).
- h. Install port engine remote module (20).
- i. Remove tags and connect electrical leads.
- j. Close cover (2) on enclosure (3) and tighten captive screws (1).

---

**3-125. Replace/Repair Annunciator (Engineer's Quarters and Galley). (Figure 3-112)**

---

**This task covers:**

- |                       |                   |                  |
|-----------------------|-------------------|------------------|
| <b>a. Inspection</b>  | <b>b. Removal</b> | <b>c. Repair</b> |
| <b>d. Replacement</b> |                   |                  |
- 

INITIAL SETUPTools

Tool kit, electrician's,  
5180-00-391-1087

Equipment Condition

Electrical power to machinery plant  
monitoring and alarm system secured  
and tagged "Out of Service - Do Not  
Operate." TM 55-1905-22-223-10

Materials/Parts

Warning tags, Item 1, Appendix C

---

INSPECTION

Check exterior of annunciator for loose or missing mounting hardware. Make sure audible alarm is screwed in securely and lamp on (Engineer Assistance Needed) push button is illuminated. Open door and check for loose connections on internal wiring, secure as required.

REMOVAL

- Loosen two latch screws (4) to release latches (5).
- Swing door (2) to the left to gain access to interior.
- Tag and disconnect electrical power cables (6) from terminal board TB1.
- Remove four machine screws (3).
- Remove annunciator (1) from bulkhead.

REPAIR

Repair at this level of maintenance is by replacement of annunciators (1).

REPLACEMENT

- Position annunciator (1) on bulkhead and secure with four machine screws (3).
- Connect electrical power cables (6) at terminal board TB1 and remove tags.

- c. Swing door (2) to the right and secure latches (5) with latch screws (4).
- d. Restore electrical power to annunciators and remove tags.

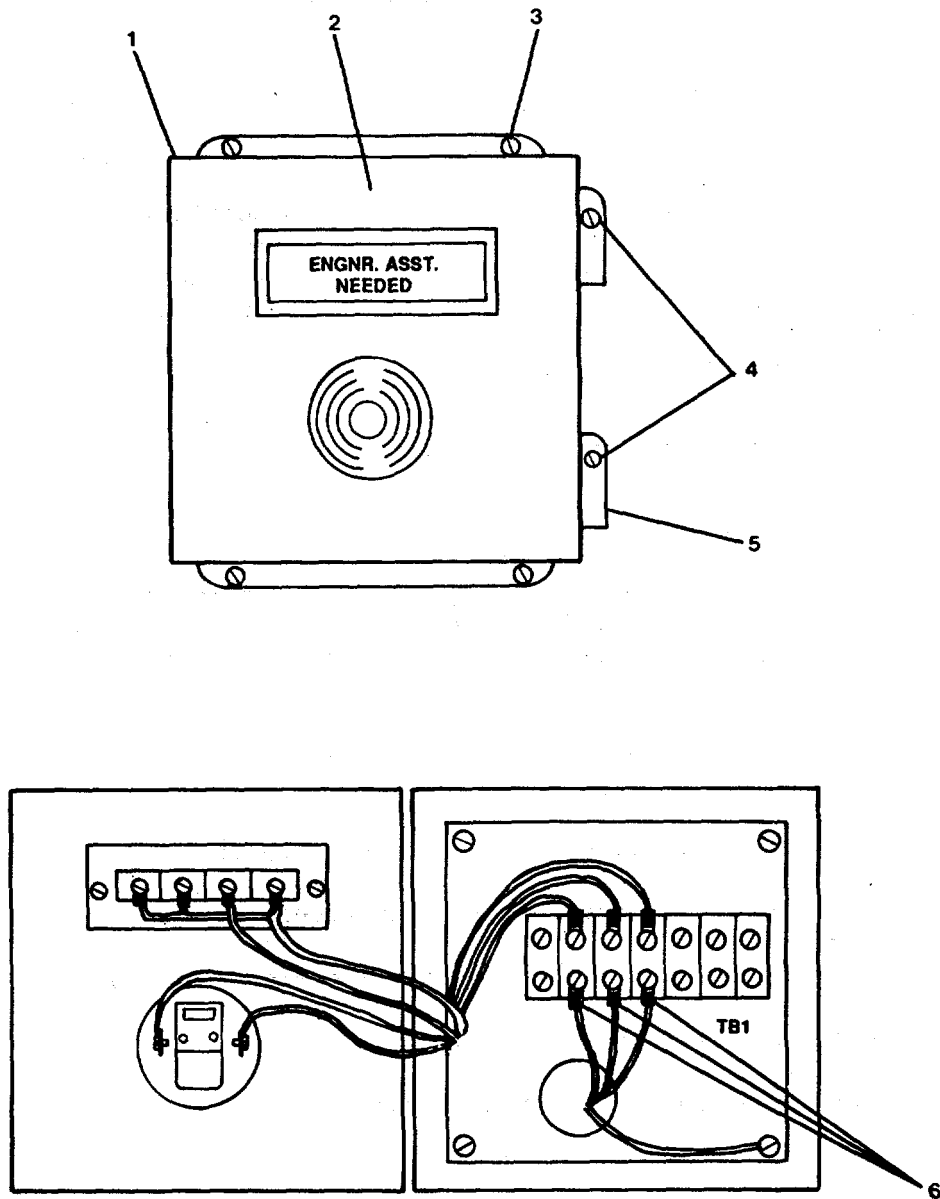

FIGURE 3-112. *Annunciator (Engineer's Quarters and Galley).*

**3-126. Replace/Repair Starboard Engine Remote Module. (Figure 3-113)**

**This task covers:**

- a. Removal**
**b. Repair**
**c. Replacement**

INITIAL SETUP

Tools

Tool kit, electrician's,  
5180-00-391-1087

Materials/Parts

Warning tags, Item 1, Appendix C

Equipment Condition

Electrical power to machinery plant monitoring and alarm system secured and tagged "Out of Service - Do Not Operate." (TM 55-1905-223-10)  
Starboard engine shut down and tagged "Out of Service - Do Not Operate." (TM 55-1905-223-10)

REMOVAL

- a. Loosen captive screws (4) and open cover (1).
- b. Tag and disconnect electrical cables from terminal switches (3).
- c. Tag and disconnect electrical cables from terminal board (5).
- d. Tag and disconnect electrical cables from terminal boards (7, 8).
- e. Remove screws (2) and remove starboard engine remote module (6).
- f. Tag and disconnect electrical cable (9) from liquid level switch (10).
- g. Tag and disconnect electrical cable (11) from liquid level switch (12).
- h. Tag and disconnect electrical cable (13) from liquid level switch (14).
- i. Tag and disconnect electrical cable (15) from pressure switch (16).
- j. Tag and disconnect electrical cable (17) from pressure switch (18).
- k. Tag and disconnect electrical cable (20) from liquid level switch (19).

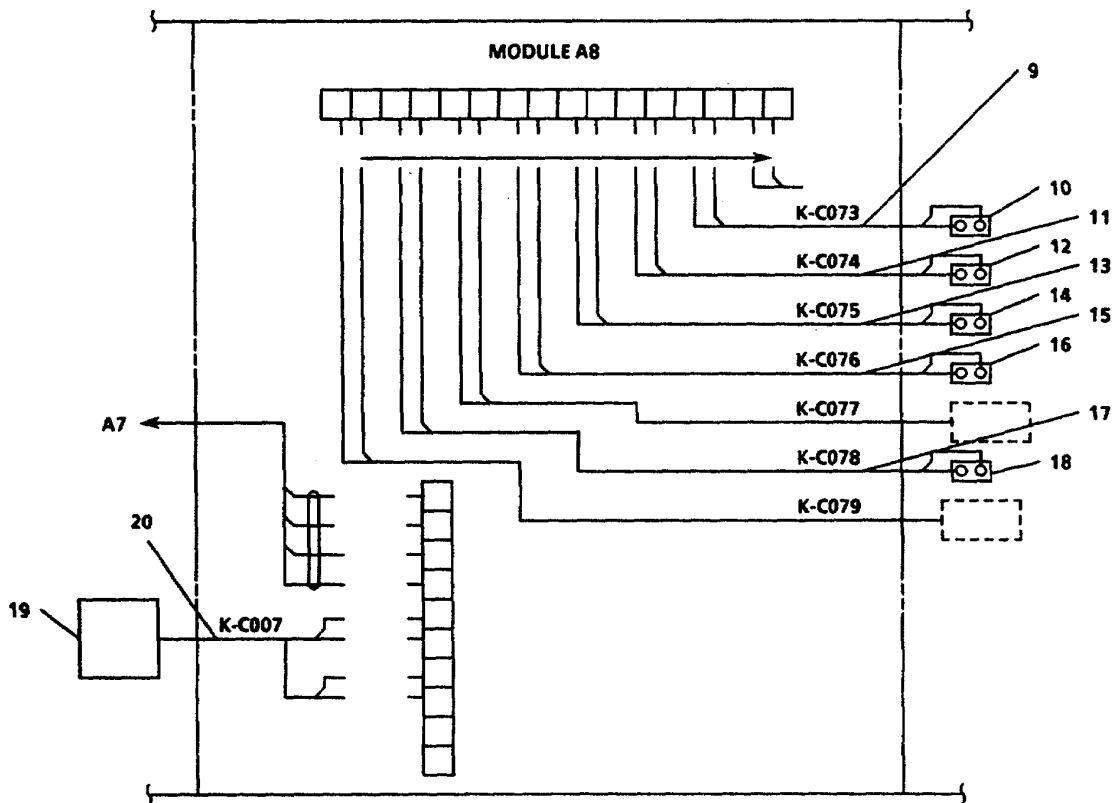
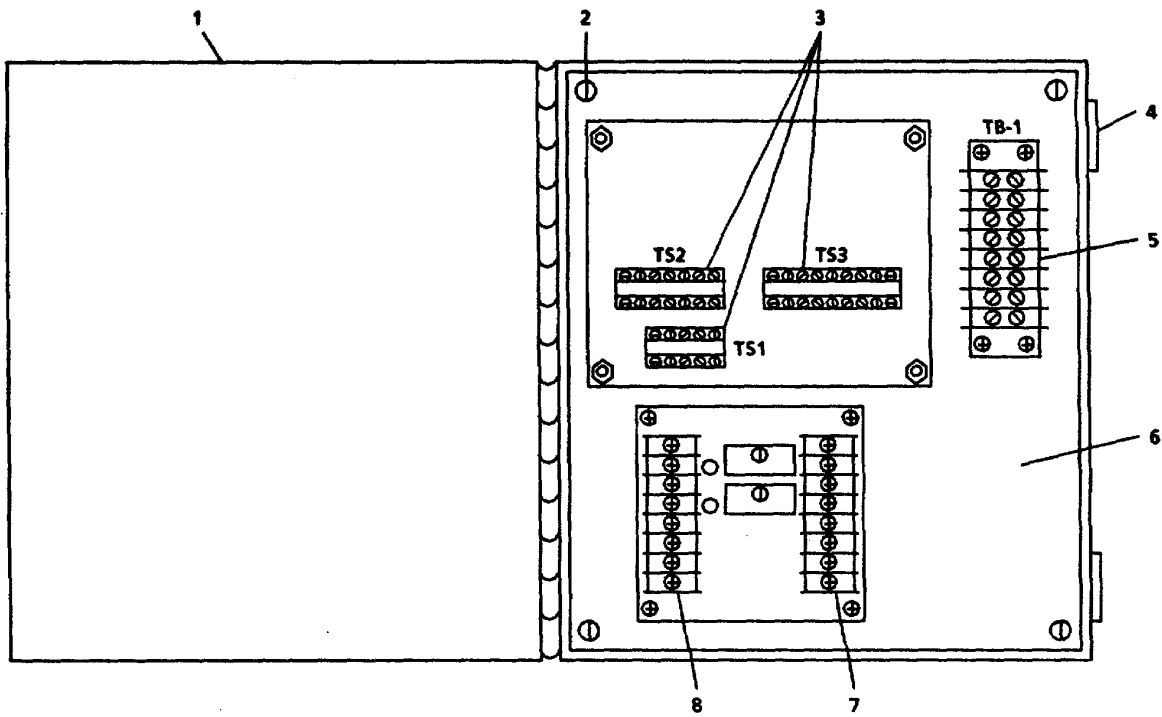

FIGURE 3-113. Starboard Engine Remote Module.



REPAIR

Repair at this level of maintenance is by replacement of starboard engine remote module (6) and cables.

REPLACEMENT

- a. Install starboard engine remote module (6) and screws (2).
- b. Remove tag and connect electrical cable (20) to liquid level switch (19).
- c. Remove tag and connect electrical power cable (17) to pressure switch (18).
- d. Remove tag and connect electrical power cable (15) to pressure switch (16).
- e. Remove tag and connect electrical power cable (13) to liquid level switch (14).
- f. Remove tag and connect electrical power cable (11) to liquid level switch (12).
- g. Remove tag and connect electrical power cable (9) to liquid level switch (10).
- h. Remove tags and connect electrical power cables to terminal boards (7, 8).
- i. Remove tags and connect electrical power cables to terminal board (5).
- j. Remove tags and connect electrical power cables to terminal switches (3).
- k. Close cover (1) and tighten captive screws (2).
- l. Remove tag and turn on electrical power to machinery plant monitoring and alarm system.

---

**3-127. Replace/Repair Bridge Panel Assembly. (Figure 3-114)**

---

**This task covers:****a. Removal****b. Repair****c. Replacement**

---

INITIAL SETUPTools

Tool kit, electrician's,  
5180-00-391-1087

Materials/Parts

Warning tags, Item 1, Appendix C

Equipment Condition

Power to machinery plant monitoring and  
alarm system secured and tagged "Out  
of Service - Do Not Operate."  
(TM 55-1905-223-10).

---

REMOVAL

- a. Remove six captive screws (2) securing bridge panel assembly (1) to control console.
- b. Carefully lift panel assembly up by handles (3) until electrical leads are accessible.
- c. Tag and disconnect electrical leads to panel assembly.
- d. Remove panel assembly from control console.

REPAIR

Repair at this level of maintenance is by replacement of bridge panel assembly.

REPLACEMENT

- a. Position panel assembly over slot in control console.
- b. Connect power leads to panel assembly. Remove tags.
- c. Install panel assembly (3) in engine room control console.
- d. Secure with six captive screws (2).
- e. Restore power to engine room panel assembly. Remove tags.
- f. Press POWER ON LAMP TEST to ensure indicators are working.

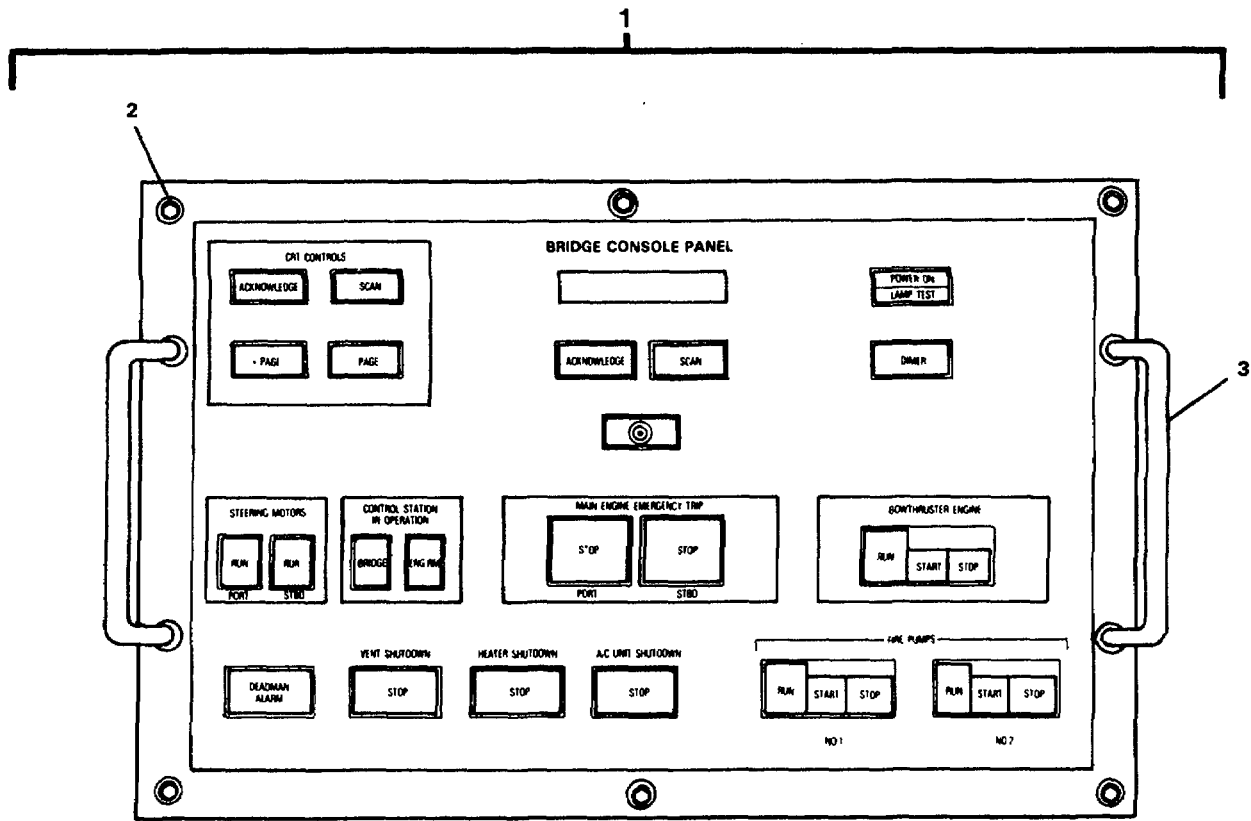

FIGURE 3-114. Machinery Plant Monitoring and Alarm System Pilothouse.

---

### 3-128. Replace/Repair Central Processing Unit.

---

#### This task covers:

- a. Removal                      b. Repair                      c. Replacement
- 

#### INITIAL SETUP

##### Tools

Tool kit, electrician's,  
5180-391-1087

##### Materials/Parts

Data entry keyboard P/N 03-09505-000  
Printed circuit board (Z-8)  
P/N 05-10301-000  
Printed circuit board (master card)  
P/N 05-09502-000  
Printed circuit board (multi-card)  
P/N 05-09503-000  
Printed circuit board (power supply)  
P/N 05-09504-100  
Warning tags, Item 1, Appendix C

##### Equipment Condition

Electrical power to machinery plant  
monitoring and alarm system secured  
and tagged "Out of Service - Do Not  
Operate."  
(TM 55-1905-223-24-10)

---

#### REMOVAL

- a. Open door (1, Figure 3-115) of enclosure (3).
- b. Tag and disconnect electrical leads to central processing unit (CPU) at connections (4).
- c. Remove four hex head bolts (2) securing CPU (5) and enclosure (3) to bulkhead.
- d. Remove CPU and enclosure.
- e. Remove screws (1, Figure 3-116) and sleeves (2) securing crossbar (3) to terminal board (10). Remove crossbar (3).
- f. Grasp printed circuit board (multi-card) (5) near the bottom and pull slightly upward until board is free of connector (4).
- g. Slide circuit board straight out until free of upper retaining slide (6).
- h. Repeat steps e. through g. for printed circuit boards (7, 12, Z-8), (8, 13, master card), (9, 14, power supply), and (11, multi-card).
- i. Tag and disconnect electrical leads at terminal strip (15).

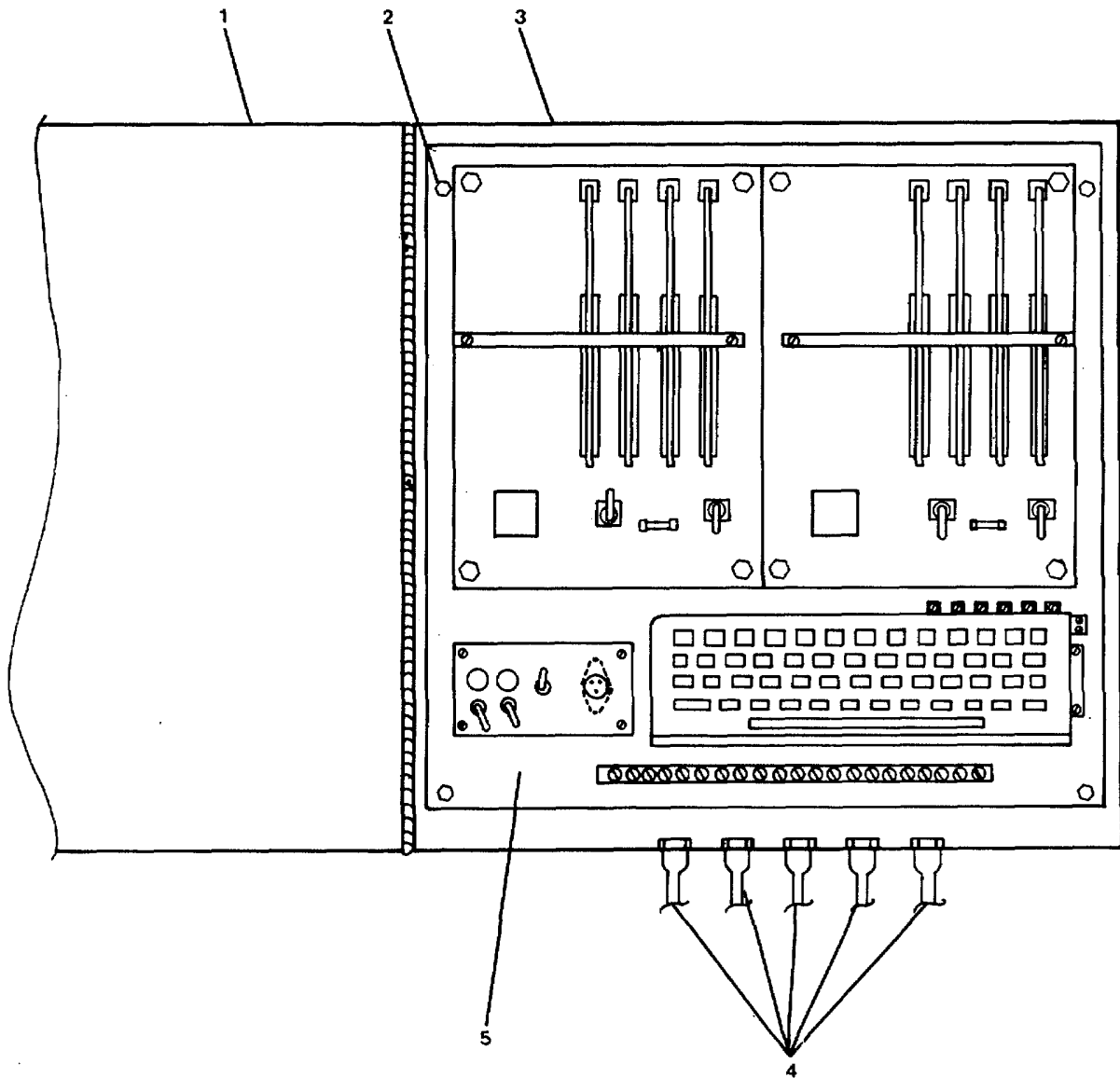

FIGURE 3-115. Central Processing Unit Removal.

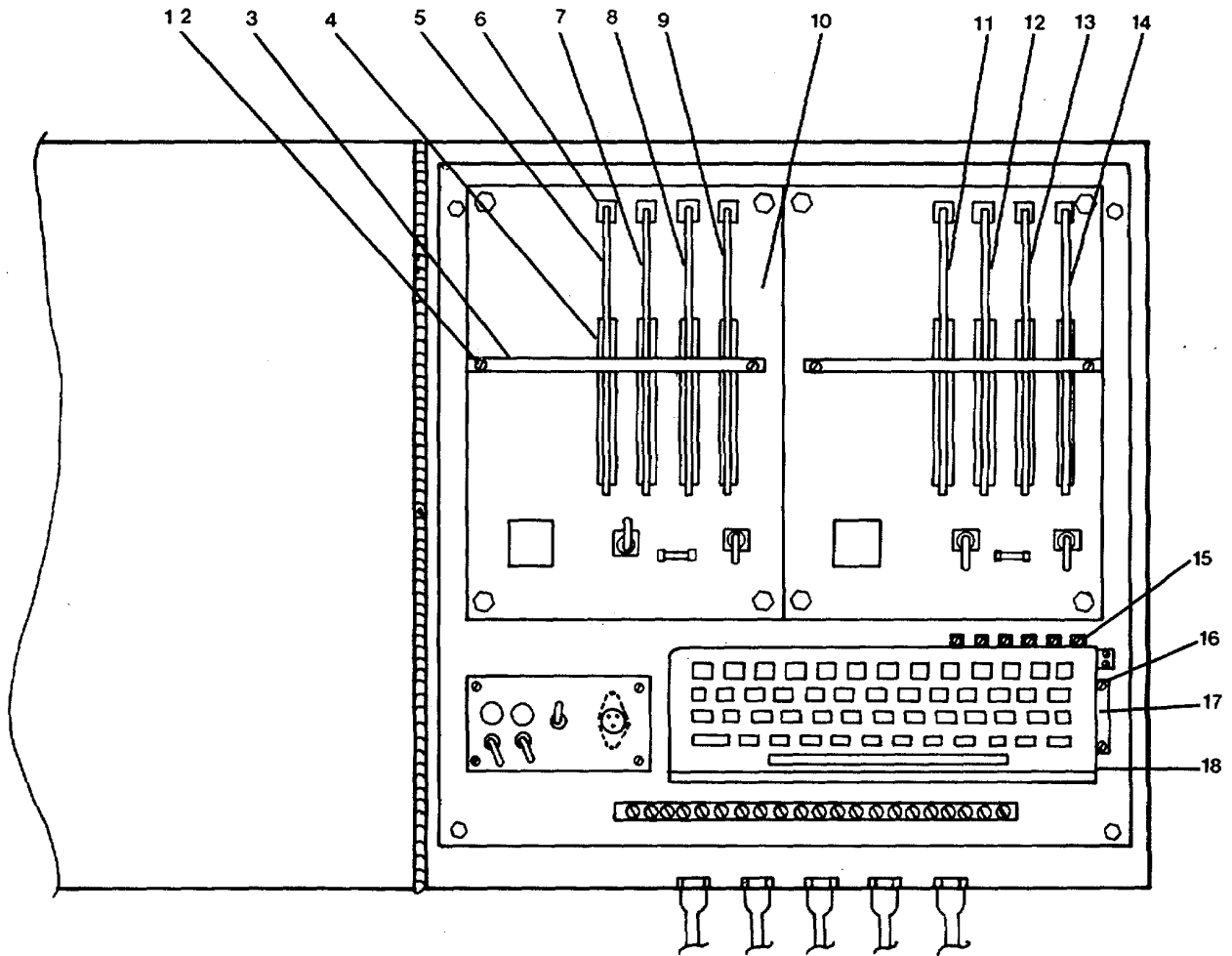

FIGURE 3-116. Central Processing Unit Repair.

- j. Remove two machine screws (16) from bracket (17) securing keyboard (18) to enclosure.
- k. Remove data entry keyboard (18).

---

## REPAIR

Repair at this level of maintenance is by replacement of printed circuit boards (5, 7, 8, 9, 11, 12, 13, and 14) and data entry keyboard (18).

---

## REPLACEMENT

- a. Install data entry keyboard (18, Figure 3-116) and secure to bracket (17) with two machine screws (16).
- b. Connect electrical leads at terminal strip (15).
- c. Slide printed circuit board (multi-card) (5) into upper retaining slide (6).
- d. Push on the circuit board until it is firmly seated in connector (4).
- e. Repeat steps c. and d. for printed circuit boards (7, 12, Z-8), (8, 13, master card), (9, 14, power supply), and (11, multi-card).
- f. Position sleeves (2) and install crossbar (3); secure with screws (1).
- g. Position central processing unit (5, Figure 3-115) and enclosure (3) on bulkhead.
- h. Secure with four hex head bolts (2).
- i. Connect electrical leads to CPU at connections (4).
- j. Close door (1).
- k. Restore electrical power to CPU and remove tags.

**3-129. Replace/Repair Analog Remote Module Assembly.**

**This task covers:**

- |   |  |                         |
|---|--|-------------------------|
| <p><b>a. Removal</b><br/><b>d. Assembly</b></p> | <p><b>b. Disassembly</b><br/><b>e. Replacement</b></p> | <p><b>c. Repair</b></p> |
|---|--|-------------------------|

INITIAL SETUP

Tools

Tool kit, electrician's,  
5180-00-391-1087

Materials/Parts

Electrical self-generating  
tachometer  
P/N 62-7008-000  
Tachometer connector  
P/N 62-7008-001  
Pressure transmitter  
P/N 62-2300-000  
Pressure transmitter  
P/N 62-2150-000  
Pressure transmitter  
P/N 62-2100-000  
Pressure transmitter  
P/N 62-2061-000  
Pressure transmitter  
P/N 62-2500-000  
Temperature sensor  
P/N 62-6005-001  
Temperature sensor  
P/N 62-6009-001  
Temperature sensor  
P/N 62-6007-001  
Temperature sensor  
P/N 62-6010-001  
Warning tags, Item 1, Appendix C  
Teflon tape, Item 5, Appendix C  
Anti-seize compound, Item 15,  
Appendix C

Equipment Condition

Electrical power to machinery plant monitoring and alarm system No. 1 and No. 2 main engine, port and starboard reduction gear, No. 1 and No. 2 ship service diesel generator, emergency fire pump and bowthruster engine secured and tagged "Out of Service - Do Not Operate." (TM 55-1905-223-10).  
Control air pressure secured and tagged "Out of Service - Do Not Operate." (TM 55-1905-223-10).  
Fire main pressure secured and tagged "Out of Service - Do Not Operate". (TM 55-1905-223-10).

REMOVAL

(Figure 3-117)

- a. Unscrew two captive screws (1) securing door (2) to enclosure (6).



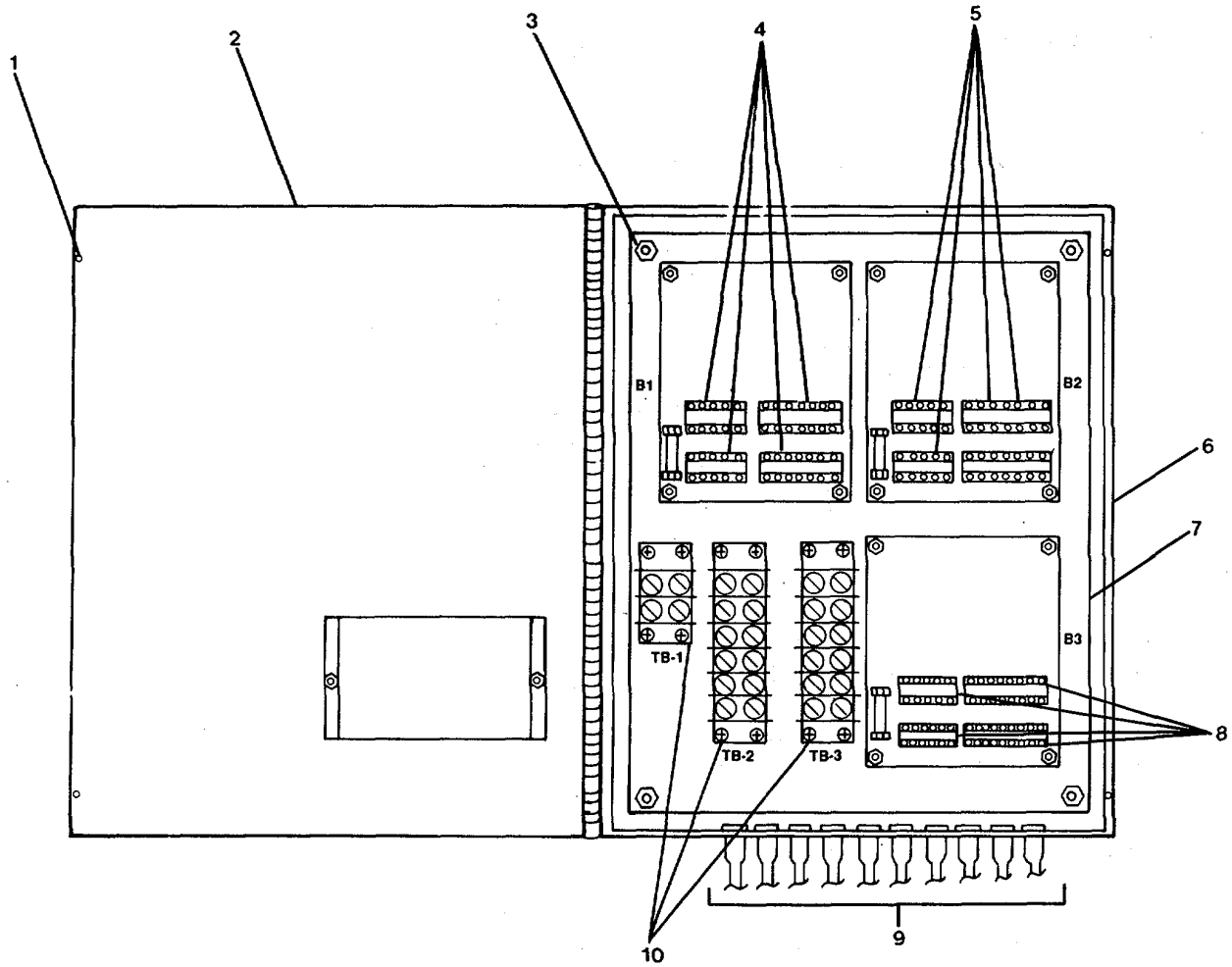

FIGURE 3-117. Analog Remote Module Assembly Removal.

- b. Swing door to the left to open.
- c. Tag and disconnect electrical leads (4, 5, and 8) at terminal strips on printed circuit boards B1, B2, and B3.
- d. Tag and disconnect electrical leads (10) at terminal boards TB1, TB2, and TB3.
- e. Let electrical leads lay down at stuffing tubes (9).
- f. Remove four hex head nuts (3).
- g. Remove analog remote module assembly (7) from enclosure (6).

WARNING

Make sure main engines, reduction gears, ship service diesel generators, bowthruster engine, and emergency fire pump are cooled down and pressures vented prior to performing maintenance to prevent personal injury from hot components, escaping air pressure or fluids.

DISASSEMBLY

(Figure 3-118)

- a. Tag and disconnect electrical power cable (11) from module B1 (1) and tachometer connector (10, Sheet 1).
- b. Unscrew electrical self-generating tachometer (9) from connector (10). Remove tachometer (9) from port engine.
- c. Tag and disconnect electrical power cable (6) from module B1 (1) and tachometer connector (8).
- d. Unscrew electrical self-generating tachometer (7) from connector (8). Remove tachometer (7) from starboard engine.
- e. Tag and disconnect electrical power cable (3) from module B1 (1) and pressure transmitter (2).
- f. Remove pressure transmitter (2) from fire main.
- g. Tag and disconnect electrical power cable (5) from module B1 (1) and pressure transmitter (4).
- h. Remove pressure transmitter (4) from control air pressure system.
- i. Tag and disconnect electrical power cable (13) from terminal box (12) and pressure transmitter (14, Sheet 2).
- j. Remove pressure transmitter (14) from bowthruster engine.

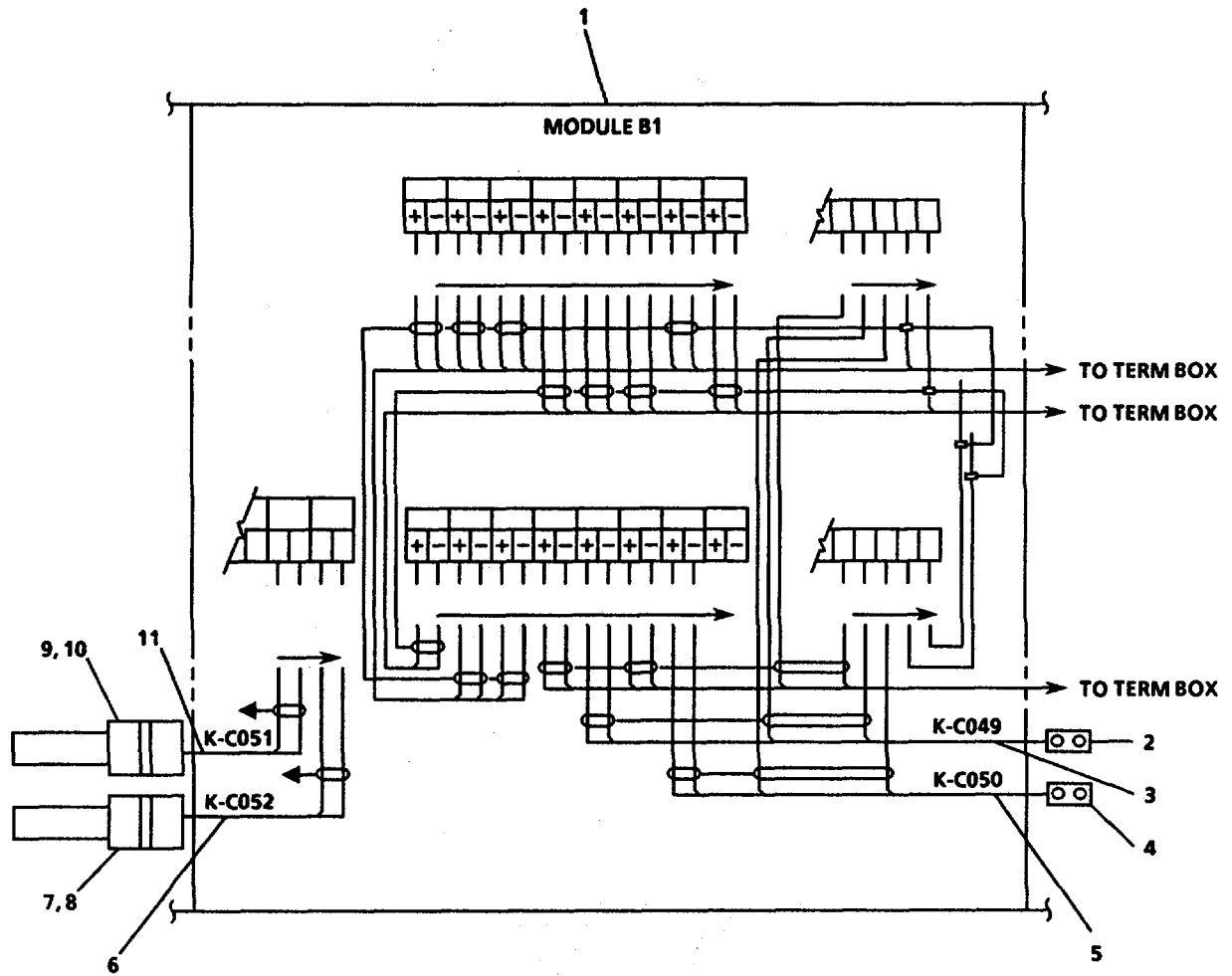

FIGURE 3-118. *Analog Remote Module Assembly. Repair (Sheet 1 of 6).*

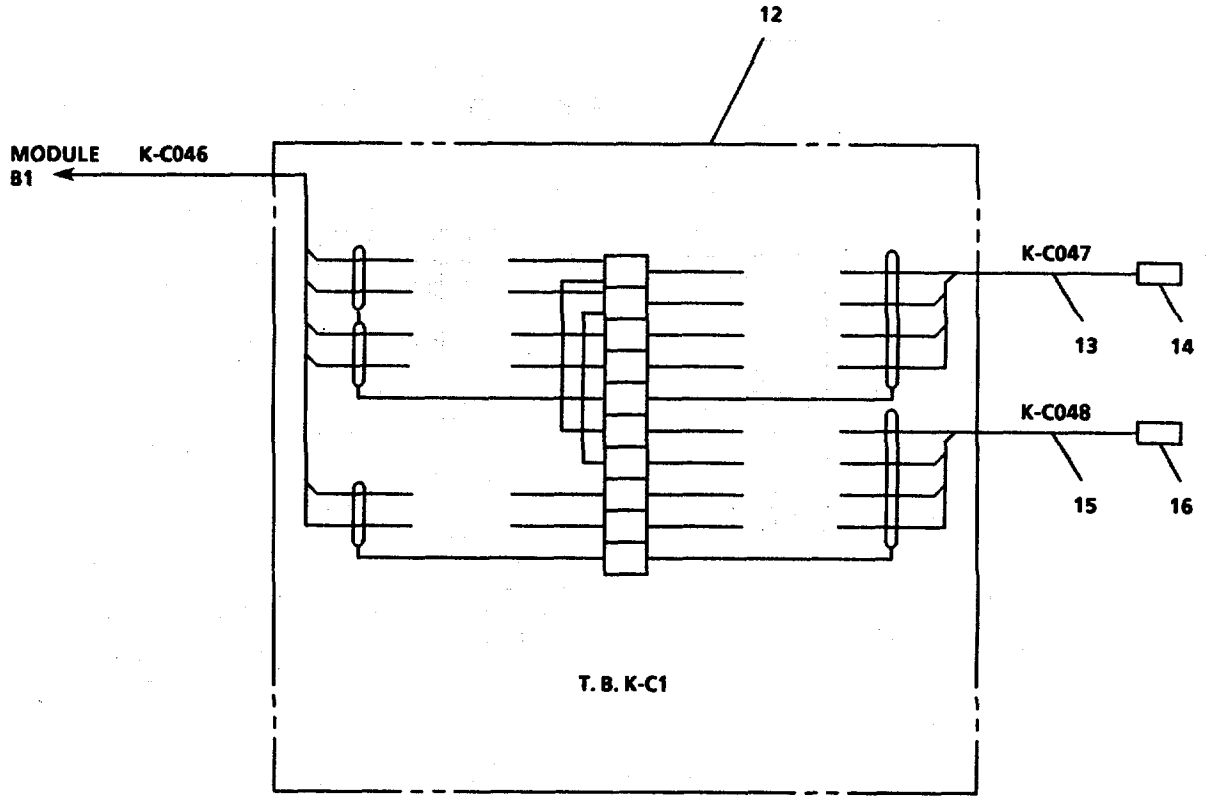

FIGURE 3-118. Analog Remote Module Assembly. Repair (Sheet 2 of 6).

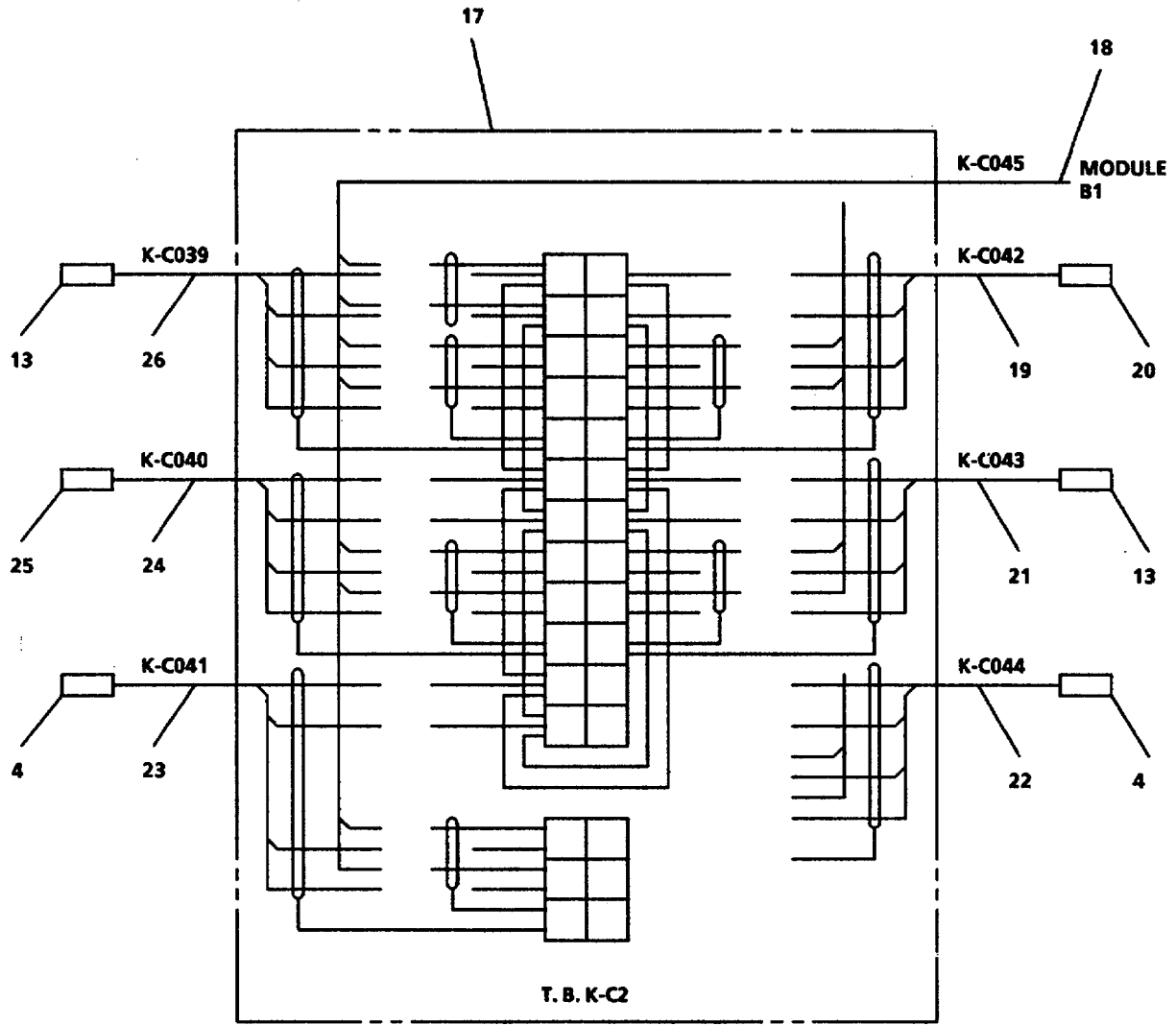

FIGURE 3-118. *Analog Remote Assembly. Repair (Sheet 3 of 6).*

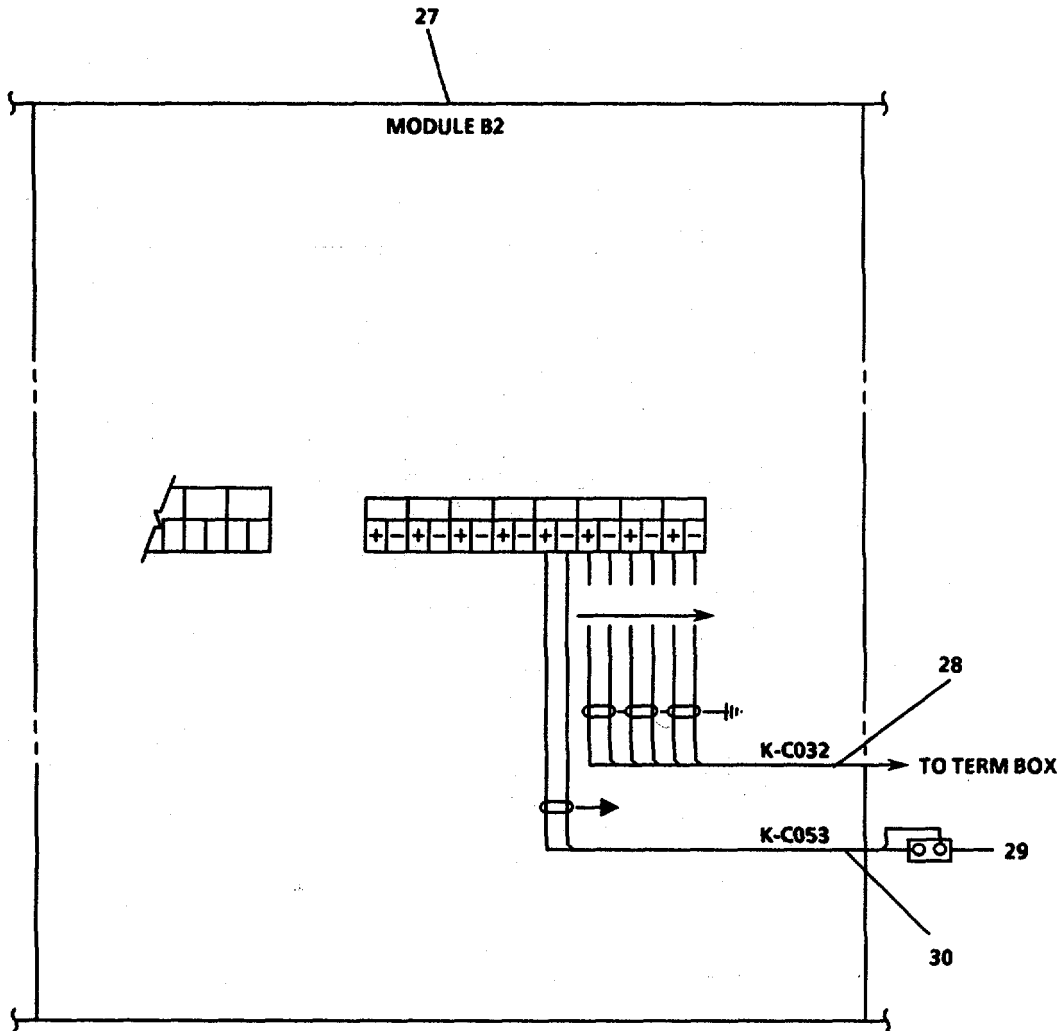

FIGURE 3-118. Analog Remote Module Assembly. Repair (Sheet 4 of 6).

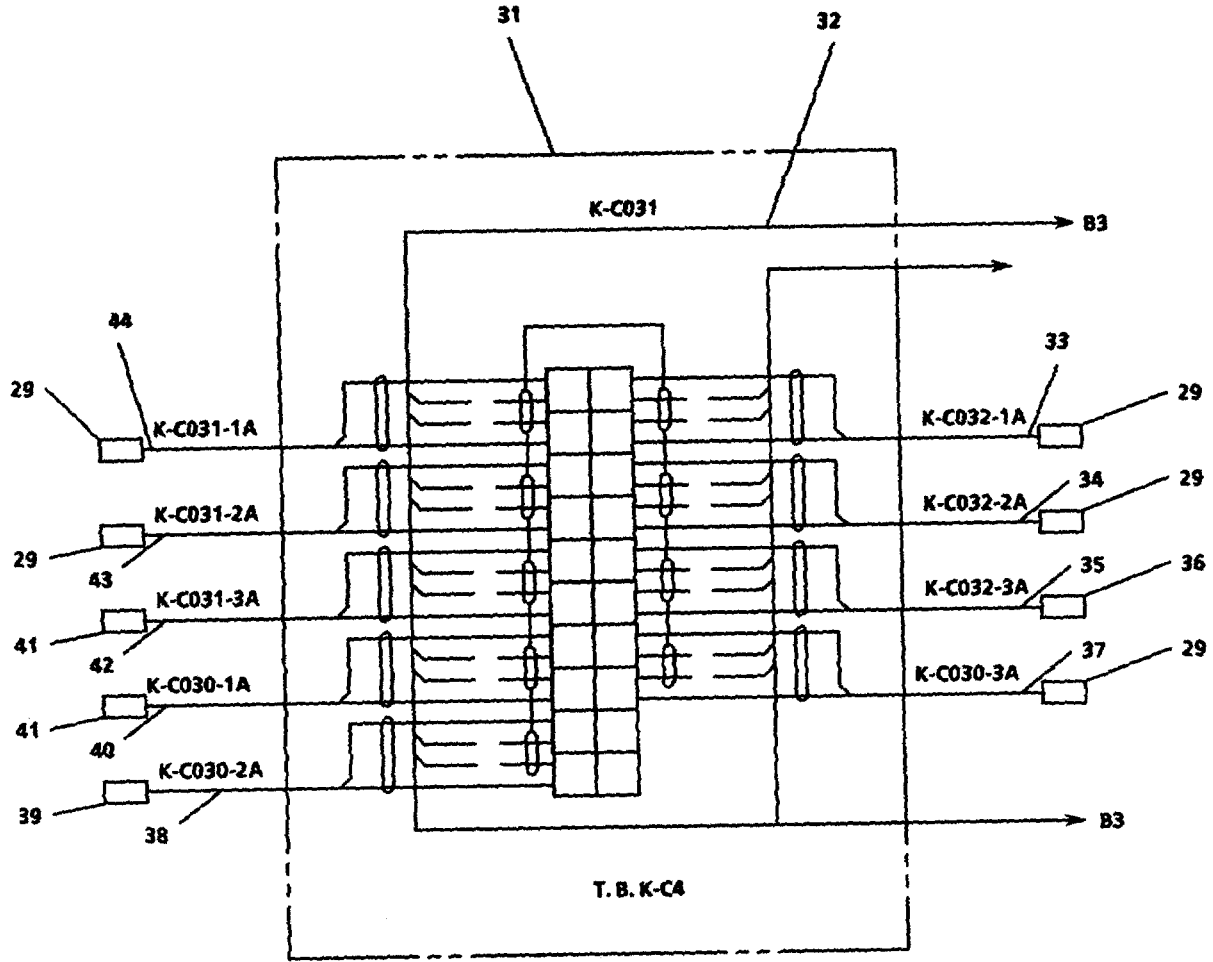

FIGURE 3-118. Analog Remote Module Assembly. Repair (Sheet 5 of 6).

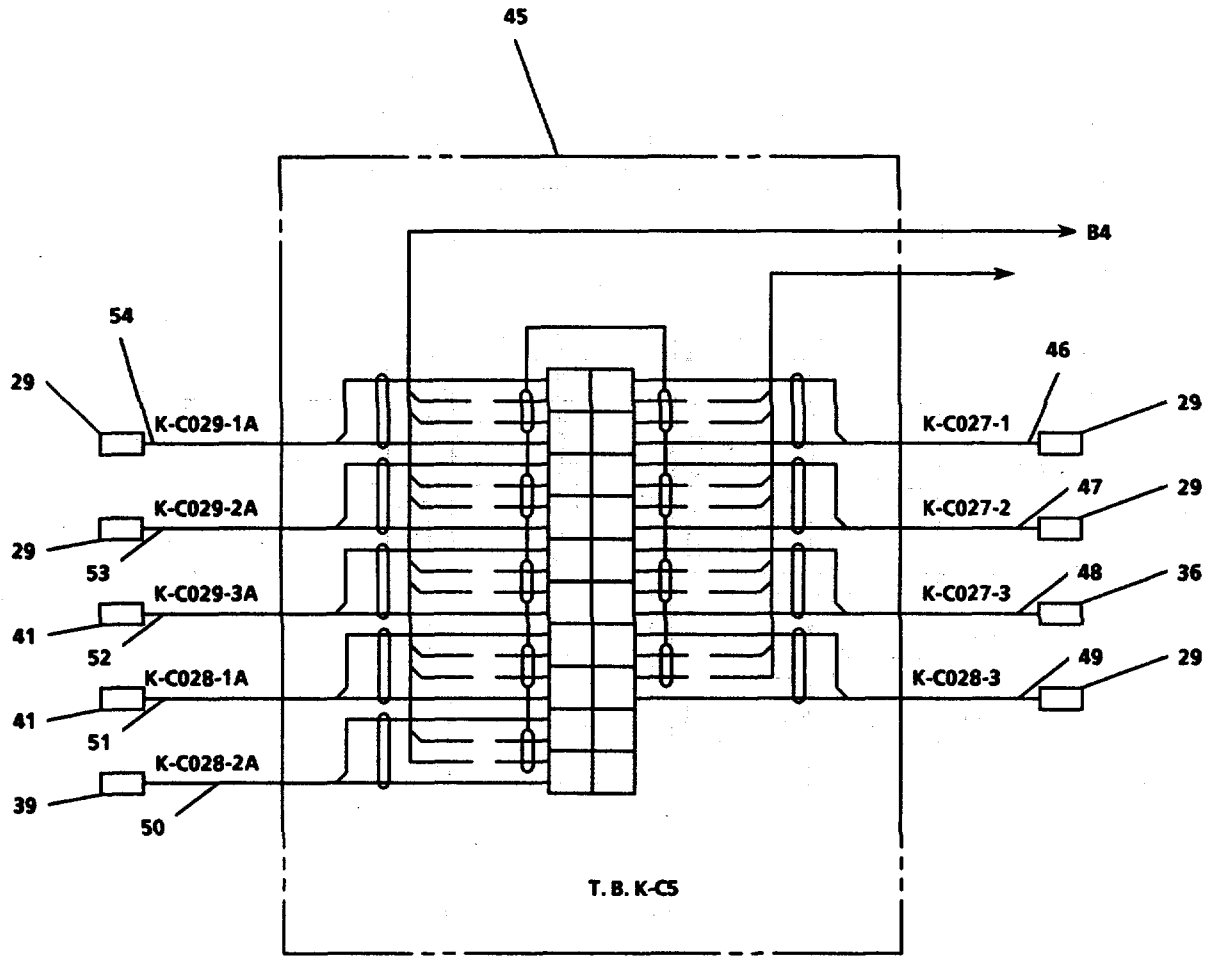

FIGURE 3-118. Analog Remote Module Assembly. Repair (Sheet 6 of 6).



- k. Tag and disconnect electrical power cable (15) from terminal box (12) and pressure transmitter (16).
- l. Remove pressure transmitter (16) from emergency fire pump.
- m. Tag and disconnect electrical power cable (19) from terminal box (17) and pressure transmitter (20, Sheet 3).
- n. Remove pressure transmitter (20) from port reduction gear.
- o. Tag and disconnect electrical power cable (21) from terminal box (17) and pressure transmitter (13).
- p. Remove pressure transmitter (13) from No. 2 ship service diesel generator.
- q. Tag and disconnect electrical power cable (22) from terminal box (17) and pressure transmitter (4).
- r. Remove pressure transmitter (4) from No. 2 ship service diesel generator.
- s. Tag and disconnect electrical power cable (23) from terminal box (17) and pressure transmitter (4).
- t. Remove pressure transmitter (4) from propulsion diesel engine No. 2.
- u. Tag and disconnect electrical power cable (24) from terminal box (17) and pressure transmitter (25).  
Remove pressure transmitter (25) from propulsion diesel engine No. 2.
- v. Tag and disconnect electrical power cable (26) from terminal box (17) and pressure transmitter (13).
- w. Remove pressure transmitter (13) from propulsion diesel engine No. 2.
- x. Tag and disconnect electrical power cable (30) from module B2 (27) and temperature sensor (29, Sheet 4).
- y. Remove temperature sensor (29) from bowthruster engine.
- z. Tag and disconnect electrical power cable (33) from terminal box (31) and temperature sensor (29, Sheet 5).
- aa. Remove temperature sensor (29) from No. 2 ship service diesel generator.
- ab. Tag and disconnect electrical power cable (34) from terminal box (31) and temperature sensor (29).
- ac. Remove temperature sensor (29) from No. 2 ship service diesel generator.
- ad. Tag and disconnect electrical power cable (35) from terminal box (31) and temperature sensor (36).
- ae. Remove temperature sensor (36) from No. 2 ship service diesel generator.

- af. Tag and disconnect electrical power cable (37) from terminal box (31) and temperature sensor (29).
- ag. Remove temperature sensor (29) from port reduction gear.
- ah. Tag and disconnect electrical power cable (38) from terminal box (31) and temperature sensor (39).
- ai. Remove temperature sensor (39) from propulsion diesel engine No. 2.
- aj. Tag and disconnect electrical power cable (40) from terminal box (31) and temperature sensor (41).
- ak. Remove temperature sensor (41) from propulsion diesel engine No. 2.
- al. Tag and disconnect electrical power cable (42) from terminal box (31) and temperature sensor (41).
- am. Remove temperature sensor (41) from propulsion diesel engine No. 2.
- an. Tag and disconnect electrical power cable (43) from terminal box (31) and temperature sensor (29).
- ao. Remove temperature sensor (29) from propulsion diesel engine No. 2.
- ap. Tag and disconnect electrical power cable (44) from terminal box (31) and temperature sensor (29).
- aq. Remove temperature sensor (29) from propulsion diesel engine No. 2.
- ar. Tag and disconnect electrical power cable (46) from terminal box (45) and temperature sensor (29, Sheet 6).
- as. Remove temperature sensor (29) from No. 1 ship service diesel generator.
- at. Tag and disconnect electrical power cable (47) from terminal box (45) and temperature sensor (29).
- au. Remove temperature sensor (29) from No. 1 ship service diesel generator.
- av. Tag and disconnect electrical power cable (48) from terminal box (45) and temperature sensor (36).
- aw. Remove temperature sensor (36) from No. 1 ship service diesel generator.
- ax. Tag and disconnect electrical power cable (49) from terminal box (45) and temperature sensor (29).
- ay. Remove temperature sensor (29) from starboard reduction gear.
- az. Tag and disconnect electrical power cable (50) from terminal box (45) and temperature sensor (39).
- ba. Remove temperature sensor (39) from propulsion diesel engine No. 1.

- bb. Tag and disconnect electrical power cable (51) from terminal box (45) and temperature sensor (41).
- bc. Remove temperature sensor (41) from propulsion diesel engine No. 1.
- bd. Tag and disconnect electrical power cable (52) from terminal box (45) and temperature sensor (41).
- be. Remove temperature sensor (41) from propulsion diesel engine No. 1.
- bf. Tag and disconnect electrical power cable (53) from terminal box (45) and temperature sensor (29).
- bg. Remove temperature sensor (29) from propulsion diesel engine No. 1.
- bh. Tag and disconnect electrical power cable (54) from terminal box (45) and temperature sensor (29).
- bi. Remove temperature sensor (29) from propulsion diesel engine No. 1.

### REPAIR

Repair at this level of maintenance is by replacement of analog remote module assembly (7, Figure 3-125), electrical self-generating tachometers (7, 9), tachometer connectors (8, 10), pressure transmitters (2, 16), pressure transmitters (4), pressure transmitters (11), pressure transmitter (20), pressure transmitter (25), temperature sensors (29), temperature sensors (36), temperature sensors (41), and temperature sensors (39).

### ASSEMBLY (Figure 3-118)

#### NOTE

- Apply anti-seize compound to the threads of temperature sensors prior to installation.
  - Apply teflon tape to the threads of temperature transmitters prior to installation.
- a. Install temperature sensor (29) in propulsion diesel engine No. 1 (Sheet 6).
  - b. Connect electrical power cable (54) at terminal box (45) and temperature sensor (29). Remove tags.
  - c. Install temperature sensor (29) in propulsion diesel engine No. 1.
  - d. Connect electrical power cable (53) at terminal box (45) and temperature sensor (29). Remove tags.
  - e. Install temperature sensor (41) in propulsion diesel engine No. 1.

- f. Connect electrical power cable (52) at terminal box (45) and temperature sensor (41). Remove tags.
- g. Install temperature sensor (41) in propulsion diesel engine No. 1.
- h. Connect electrical power cable (51) at terminal box (45) and temperature sensor (41). Remove tags.
- i. Install temperature sensor (39) in propulsion diesel engine No. 1.
- j. Connect electrical power cable (50) at terminal box (45) and temperature sensor (39). Remove tags.
- k. Install temperature sensor (29) in starboard reduction gear.
- l. Connect electrical power cable (49) at terminal box (45) and temperature sensor (29). Remove tags.
- m. Install temperature sensor (36) in No. 1 ship service diesel generator.
- n. Connect electrical power cable (48) at terminal box (45) and temperature sensor (36). Remove tags.
- o. Install temperature sensor (29) in No. 1 ship service diesel generator.
- p. Connect electrical power cable (47) at terminal box (45) and temperature sensor (29). Remove tags.
- q. Install temperature sensor (29) in No. 1 ship service diesel generator.
- r. Connect electrical power cable (46) at terminal box (45) and temperature sensor (29). Remove tags.
- s. Install temperature sensor (29) in propulsion diesel engine No. 2.
- t. Connect electrical power cable (44) at terminal box (31) and temperature sensor (29). Remove tags (Sheet 5).
- u. Install temperature sensor (29) in propulsion diesel engine No. 2.
- v. Connect electrical power cable (43) at terminal box (31) and temperature sensor (29). Remove tag.
- w. Install temperature sensor (41) in propulsion diesel engine No. 2.
- x. Connect electrical power cable (42) at terminal box (31) and temperature sensor (41). Remove tags.
- y. Install temperature sensor (41) in propulsion diesel engine No. 2.
- z. Connect electrical power cable (40) at terminal box (31) and temperature sensor (41). Remove tags.
- aa. Install temperature sensor (39) in propulsion diesel engine No. 2.

- ab. Connect electrical power cable (38) at terminal box (31) and temperature sensor (39). Remove tags.
- ac. Install temperature sensor (29) in port reduction gear.
- ad. Connect electrical power cable (37) at terminal box (31) and temperature sensor (29). Remove tags.
- ae. Install temperature sensor (36) in No. 2 ship service diesel generator.
- af. Connect electrical power cable (35) at terminal box (31) and temperature sensor (36). Remove tags.
- ag. Install temperature sensor (29) in No. 2 ship service diesel generator.
- ah. Connect electrical power cable (34) at terminal box (31) and temperature sensor (29). Remove tags.
- ai. Install temperature sensor (29) in No. 2 ship service diesel generator.
- aj. Connect electrical power cable (33) at terminal box (31) and temperature sensor (29). Remove tags.
- ak. Install temperature sensor (29) in bowthruster engine.
- al. Connect electrical power cable (30) at module B2 (27) and temperature sensor (29). Remove tags (Sheet 4).
- am. Install pressure transmitter (13) in propulsion diesel engine No. 2 (Sheet 3).
- an. Connect electrical power cable (26) at terminal box (17) and pressure transmitter (13). Remove tags.
- ao. Install pressure transmitter (25) in propulsion diesel engine No. 2.
- ap. Connect electrical power cable (24) at terminal box (17) and pressure transmitter (25). Remove tags.
- aq. Install pressure transmitter (4) in propulsion diesel engine No. 2.
- ar. Connect electrical power cable (23) at terminal box (17) and pressure transmitter (4). Remove tags.
- as. Install pressure transmitter (4) in No. 2 ship service diesel generator.
- at. Connect electrical power cable (22) at terminal box (17) and pressure transmitter (4). Remove tags.
- au. Install pressure transmitter (13) in No. 2 ship service diesel generator.
- av. Connect electrical power cable (21) at terminal box (17) and pressure transmitter (13). Remove tags.
- aw. Install pressure transmitter (20) in port reduction gear.

- ax. Connect electrical power cable (19) at terminal box (17) and pressure transmitter (20). Remove tags.
- ay. Install pressure transmitter (16) in emergency fire pump (Sheet 2).
- az. Connect electrical power cable (15) at terminal box (12) and pressure transmitter (16). Remove tags.
- ba. Install pressure transmitter (14) in bowthruster engine.
- bb. Connect electrical power cable (13) at terminal box (12) and pressure transmitter (14). Remove tags.
- bc. Install pressure transmitter (4) in control air pressure system (Sheet 1).
- bd. Connect electrical power cable (5) in module B1 (1) and pressure transmitter (4). Remove tags.
- be. Install pressure transmitter (2) in fire main control panel.
- bf. Connect electrical power cable (3) in module B1 (1) and pressure transmitter (2)-. Remove tags.
- bg. Install electrical self-generating tachometer (7) in starboard engine.
- bh. Secure tachometer connector (8).
- bi. Connect electrical power cable (6) in module B1 (1) and at tachometer connector (8). Remove tags.
- bj. Install electrical self-generating tachometer (9) in port engine.
- bk. Secure tachometer connector (10).
- bl. Connect electrical power cable (11) in module B1 (1) and at tachometer connector (10). Remove tags.

**REPLACEMENT** (Figure 3-117)

- a. Position analog remote module assembly (7) in enclosure (6, Sheet 1).
- b. Secure with four hex head nuts (3).
- c. Lift electrical leads up and away from stuffing tubes (9).
- d. Connect electrical leads (10) at terminal boards TB1, TB2, and TB3. Remove tags.
- e. Connect electrical leads (4, 5, and 7) at terminal strips on printed circuit boards B1, B2, and B3. Remove tags.
- f. Close door (2) by swinging to the right. Secure to enclosure (6) with two captive screws (1).

- g. Restore fire main pressure; reference Operator's Manual TM 55-1905-223-10. Remove tag.
- h. Restore control air pressure; reference Operator's Manual TM 55-1905-223-10.
- i. Restore bowthruster engine, emergency fire pump, No. 1 and No. 2 ship service diesel generator, port and starboard reduction gear, and No. 1 and No. 2 main engines to operational condition and remove tags.
- j. Restore electrical power to bowthruster engine, emergency fire pump, No. 1 and No. 2 ship service diesel generator, port and starboard reduction gears, No. 1 and No. 2 main engines, and analog remote module assembly. Remove tags.

**3-130. Replace/Repair Generators Remote Module. (Figure 3-119)**

**This task covers:**

**a. Removal**

**b. Cleaning**

**c. Replacement**

**INITIAL SETUP:**

Tools

Tool kit, electrician's,  
5180-00-391-1087

Equipment Condition

Electrical power to machinery plant  
monitoring and alarm system  
secured and tag 'Out of Service -  
Do Not Operate.' TM 55-1905-223-10

Materials/Parts

Warning tag, Item 1, Appendix C

LOCATION	ITEM	ACTION	REMARKS
----------	------	--------	---------

**REMOVAL**

- a. Loosen captive screws (1) and open cover (2).
- b. Tag and disconnect electrical leads.
- c. Remove generators remote module (4) from enclosure (3).
- d. Tag and disconnect electrical power cable (19) from liquid level switch (18).
- e. Tag and disconnect electrical power cable (17) from liquid level switch (16).
- f. Tag and disconnect electrical power cable (14) from liquid level switch (15).
- g. Tag and disconnect electrical power cable (12) from MCCP210 (13).
- h. Tag and disconnect electrical power cable (11) from INTFC (6).
- i. Tag and disconnect electrical power cable (9) from INTFC (7).
- j. Tag and disconnect electrical power cable (10) from INTFC (8).
- k. Tag and disconnect electrical power cable (5).

**Change 1 3-464**



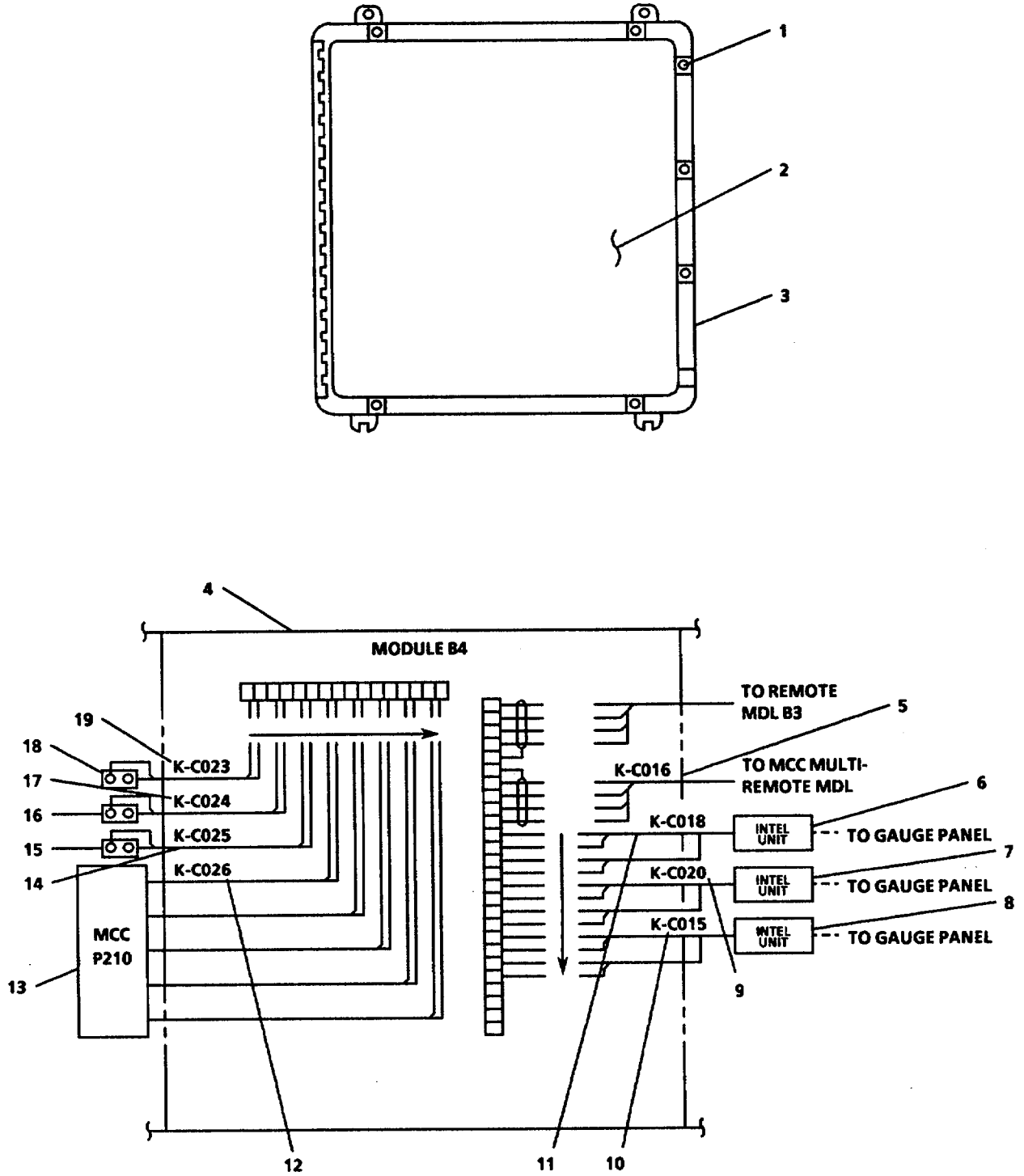

FIGURE 3-119. *Generators Remote Module.*  
3-465

## REPAIR

Repair at this level of maintenance is by replacement of generators remote module (4) and cables.

## REPLACEMENT

- a. Remove tag and connect electrical power cable (5).
- b. Remove tag and connect electrical power cable (10) to INTFC (8).
- c. Remove tag and connect electrical power cable (9) to INTFC (7).
- d. Remove tag and connect electrical power cable (11) to INTFC (6).
- e. Remove tag and connect electrical power cable (12) to MCCP210 (12).
- f. Remove tag and connect electrical power cable (14) to liquid level switch (15).
- g. Remove tag and connect electrical power cable (17) to liquid level switch (16).
- h. Remove tag and connect electrical power cable (19) to liquid level switch (18).
- i. Install generators remote module (4) in enclosure (3).
- j. Remove tags and connect electrical leads.
- k. Close cover (2).and tighten captive screws (1).
- l. Remove tag and turn on electrical power to machinery plant monitoring and alarm system.

**3-131. Replace/Repair Interface Unit Assembly. (Figure 3-120)**

This task covers:

a. Removal

b. Repair

c. Replacement

**INITIAL SETUP :**

Tools

Tool kit, electrician's,  
5180-00-391-1087

Equipment Condition

Electrical power to machinery plant  
monitoring and alarm system  
secured and tag 'Out of Service -  
Do Not Operate.' TM 55-1905-223-10

Materials/Parts

Warning tag, Item 1, Appendix C

LOCATION	ITEM	ACTION	REMARKS
----------	------	--------	---------

**NOTE**

This task applies to the three interface unit assemblies associated with the machinery plant monitoring and alarm system.

**REMOVAL**

- a. Loosen captive screws (1) and open cover (2).
- b. Tag and disconnect wiring from terminal boards.
- c. Remove mounting screws (4).
- d. Remove interface unit assembly (3).

**REPAIR**

Repair at this level is by replacement of interface unit assembly.

**REPLACEMENT**

- a. Mount interface unit assembly (3) on bulkhead. Secure with mounting screws (4).
- b. Connect wiring to terminal boards. Remove tags.
- c. Close door (2), Tighten captive screws (1).
- d. Turn power to machinery plant monitoring and alarm system on and remove tags.

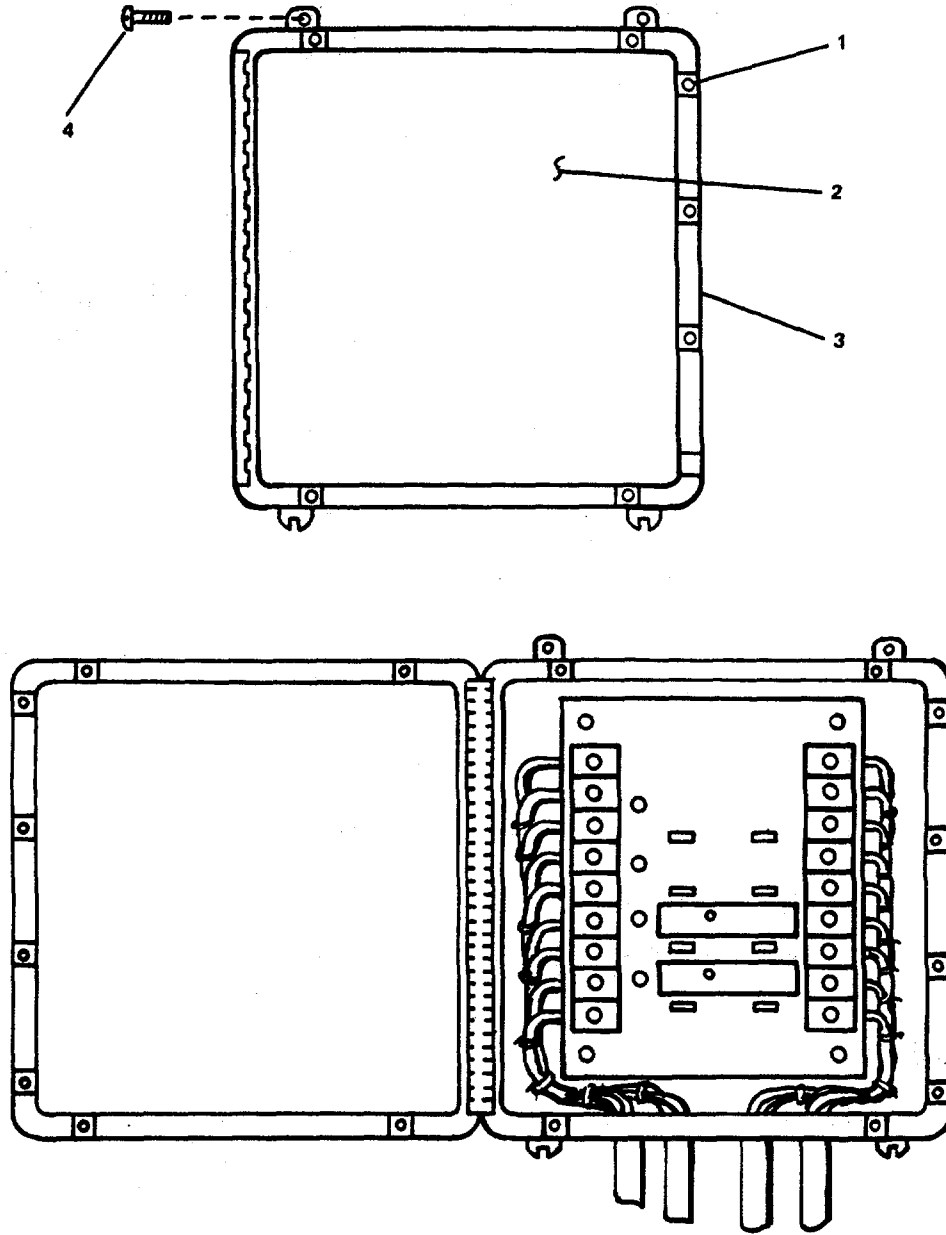

FIGURE 3-120. Interface Unit Assembly.

**3-132. Replace/Repair Motor Controllers Multi-Remote Module. (Figure 3-121)**

This task covers:

a. Removal

b. Repair

c. Replacement

**INITIAL SETUP :**

Tools

Tool kit, electrician's,  
5180-00-391-1087

Equipment Condition

Electrical power to machinery plant  
monitoring and alarm system  
secured and tag 'Out of Service -  
Do Not Operate.' (TM 55-1905-223-10)

Materials/Parts

Warning tags, Item 1, Appendix C

LOCATION	ITEM	ACTION	REMARKS
----------	------	--------	---------

**REMOVAL**

- a. Loosen captive screws (1) and open cover (2, Sheet 1).
- b. Tag and disconnect electrical leads.
- c. Remove motor controller multi-remote module (5) from enclosure (3).
- d. Tag and disconnect electrical power cable (4) from PORT STRG GEAR PUMP (17).
- e. Tag and disconnect electrical power cable (13) from MCCP205 (16).
- f. Tag and disconnect electrical power cable (14) from MCCP205 (15).
- g. Tag and disconnect electrical power cable (6) from STBD STRG GEAR PUMP (7).
- h. Tag and disconnect electrical power cable (24) from FIRE PUMP NO. 2 (27, Sheet 2).
- i. Tag and disconnect electrical power cable (23) from FIRE PUMP NO. 1 (28).
- j. Tag and disconnect electrical power cable (11) from F.W. PRESS PUMP NO. 2 (10, Sheet 1).
- k. Tag and disconnect electrical power cable (25) from BILGE/BALLAST PUMP (26, Sheet 2).

**Change 1 3-469**

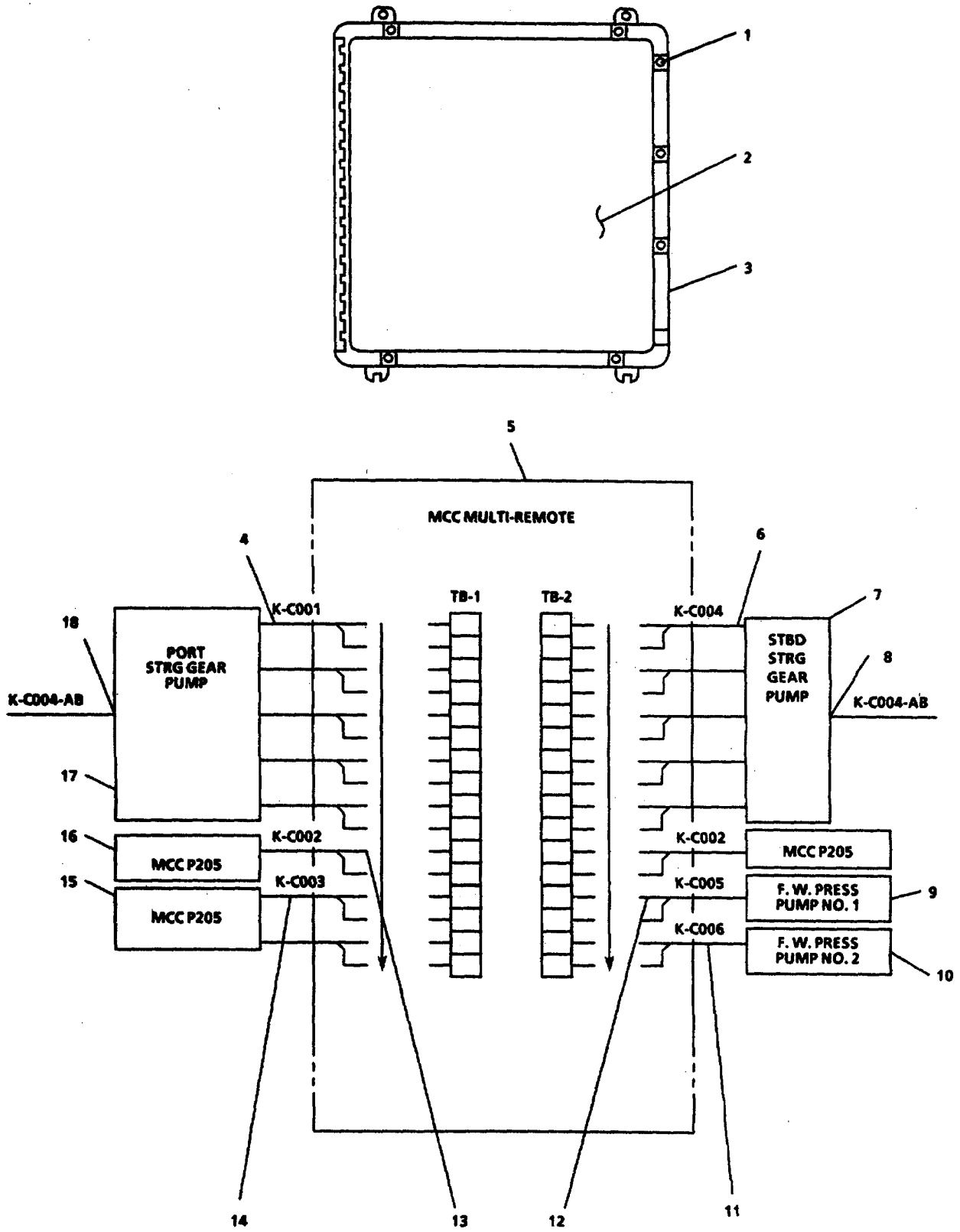

FIGURE 3-121. Motor Controllers Multi-Remote Module (Sheet 1 of 4).  
3-470

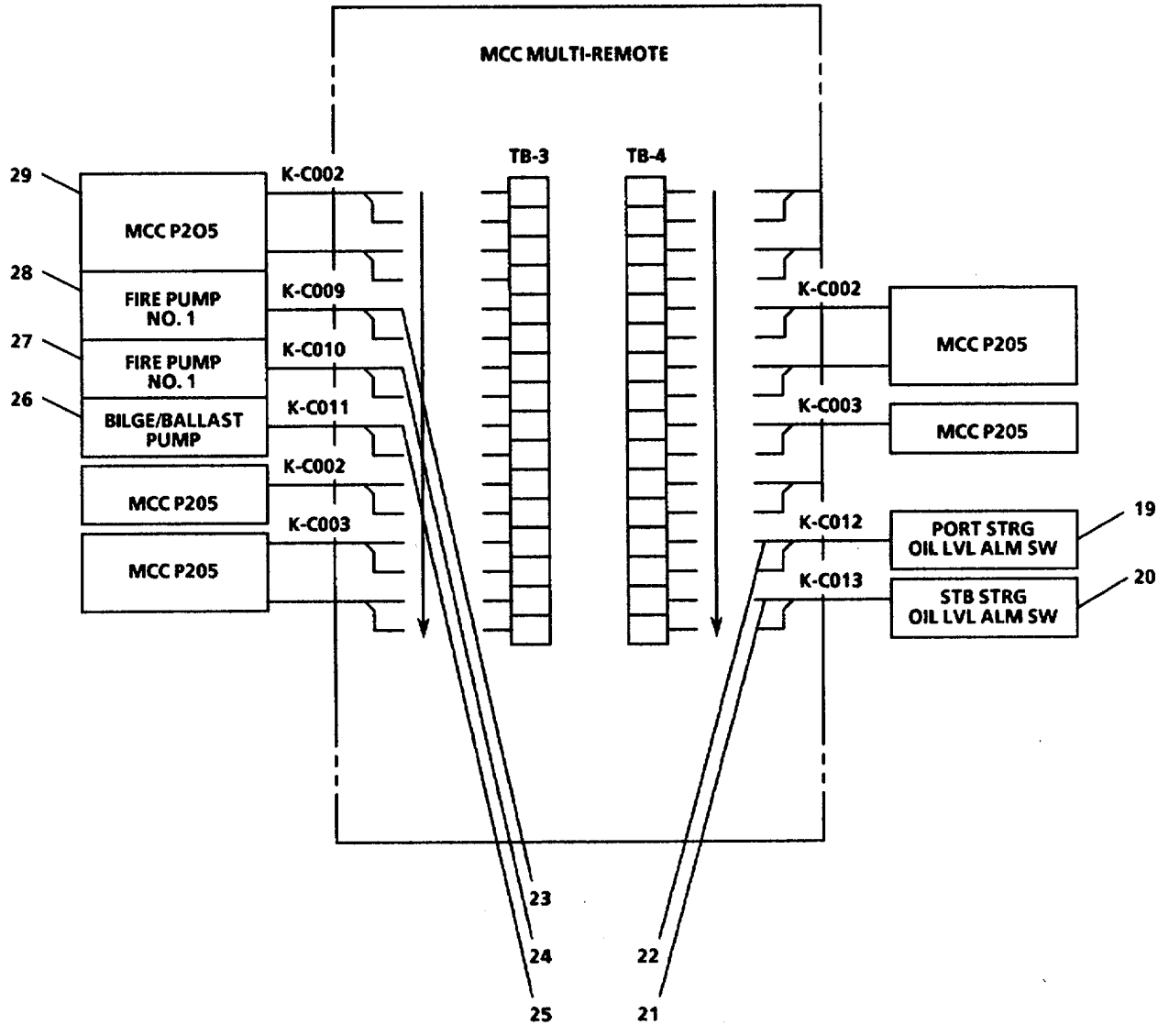

FIGURE 3-121. Motor Controllers Multi-Remote Module (Sheet 2 of 4).

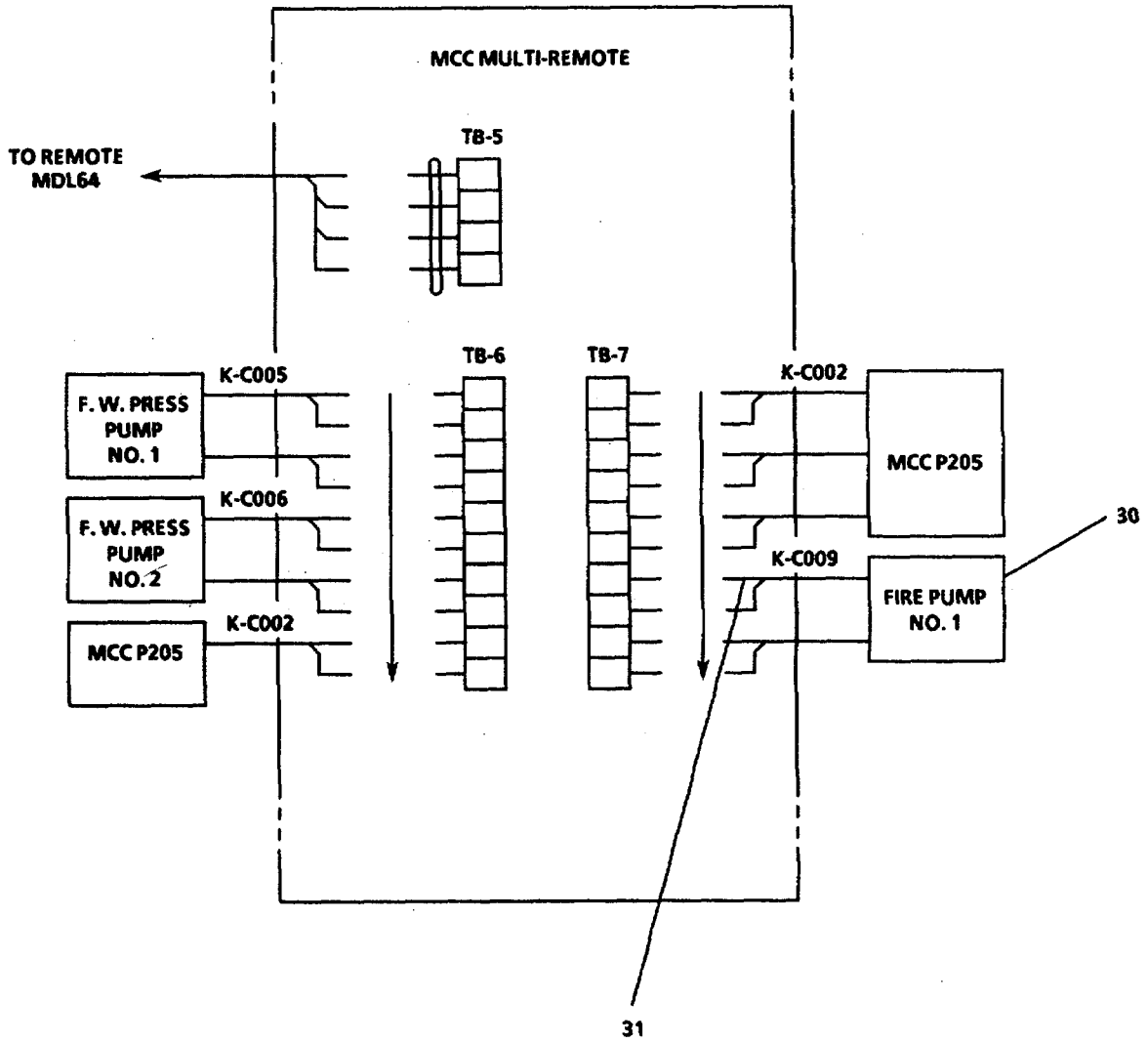

FIGURE 3-121. Motor Controllers Multi-Remote Module (Sheet 3 of 4).



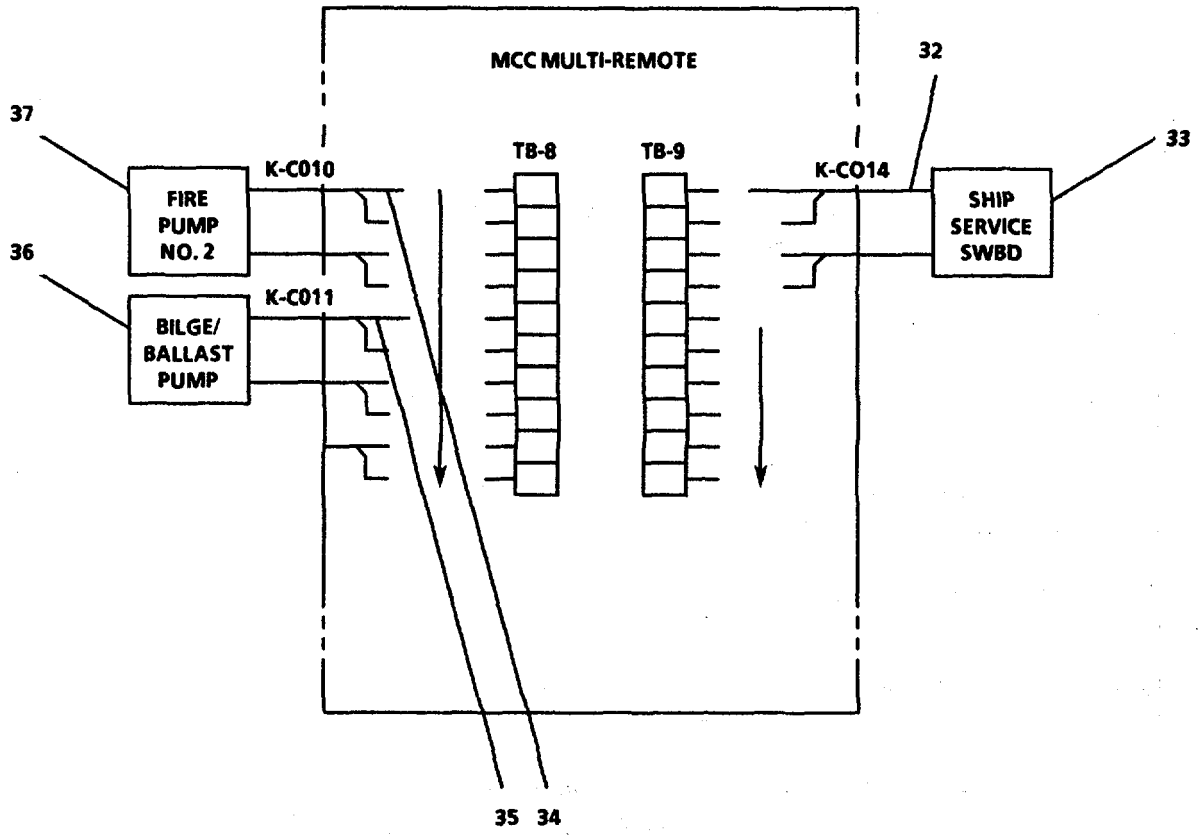

FIGURE 3-121. Motor Controllers Multi-Remote Module (Sheet 4 of 4).

- l. Tag and disconnect electrical power cable (12) from F.W. PRESS PUMP NO. 1 (9, Sheet 1).
- m. Tag and disconnect electrical power cable (18) from PORT STRG GEAR PUMP (17).
- n. Tag and disconnect electrical power cable (8) from STBD STRG GEAR PUMP (7).
- o. Tag and disconnect electrical power cable (22) from PORT STRG OIL LVL ALM SYS (19, Sheet 2).
- p. Tag and disconnect electrical power cable (21) from STBD STRG OIL LVL ALM SYS (20).
- q. Tag and disconnect electrical power cable (32) from SHIP SERVICE SWBD (33, Sheet 4).

## REPAIR

Repair at this level of maintenance is by replacement of motor controller multi-remote module (5, Sheet 1) and cables.

## REPLACEMENT

- a. Remove tag and connect electrical power cable (32) to SHIP SERVICE SWBD (33, Sheet 4).
- b. Remove tag and connect electrical power cable (21) to STBD STRG OIL LVL ALM SYS (20, Sheet 2).
- c. Remove tag and connect electrical power cable (22) to PORT STRG OIL LVL ALM SYS (19).
- d. Remove tag and connect electrical power cable (6) to STBD STRG GEAR PUMP (7, Sheet 1).
- e. Remove tag and connect electrical power cable (18) to PORT STRG GEAR PUMP (17).
- f. Remove tag and connect electrical power cable (12) to F.W. PRESS PUMP NO. 1 (9).
- g. Remove tag and connect electrical power cable (25) to BILGE/BALLAST PUMP (26, Sheet 2).
- h. Remove tag and connect electrical power cable (11) to F.W. PRESS PUMP NO. 2 (10, Sheet 1).
- i. Remove tag and connect electrical power cable (23) to FIRE PUMP NO. 1 (28, Sheet 2).
- j. Remove tag and connect electrical power cable (24) to FIRE PUMP NO. 2 (27).
- k. Remove tag and connect electrical power cable (8) to STBD STRG GEAR PUMP (7).

- l. Remove tag and connect electrical power cable (14) to MCCP205 (15).
- m. Remove tag and connect electrical power (13) to MCCP205 (16).
- n. Remove tag and connect electrical power cable (4) to PORT STRG GEAR PUMP (17).
- o. Install motor controller multi-remote module (5) in enclosure (3, Sheet 1).
- p. Remove tags and connect electrical leads.
- q. Close cover (2) and tighten captive screws (1).
- r. Remove tag and turn on electrical power to machinery plant monitoring and alarm system.



---

**3-134. Replace/Repair Bridge Panel Assembly. (Figure 3-122)**

---

**This task covers:**

- a. Removal,                      b. Repair,                      f. Replacement**
- 

**INITIAL SETUP:**Tools

Tool kit, electrician's,  
5180-00-391-1087

Equipment Condition

Electrical power to engine order  
telegraph system secured and tagged  
"Out of Service - Do Not Operate."  
(TM 55-1905-223-10)

Materials/Parts

Warning tags, Item 1, Appendix C

---

**REMOVAL**

- a. Remove eight round head screws (2).
- b. Remove four allen head screws (3).
- c. Grasp handles (4) and carefully pull panel (1) upward until electrical leads are accessible.
- d. Tag and disconnect electrical leads to 28 push switches.

**REPAIR**

Repair at this level of maintenance is by replacement of the panel assembly.

**REPLACEMENT**

- a. Connect electrical leads to 28 push switches and remove tags.
- b. Grasp handles (4) and insert engine room panel assembly (1) into engine room control console.
- c. Secure with four allen head screws (3) and eight round head screws (2).
- d. Restore power to panel and remove tags.
- e. Press POWER ON LAMP TEST to ensure indicators are working properly.

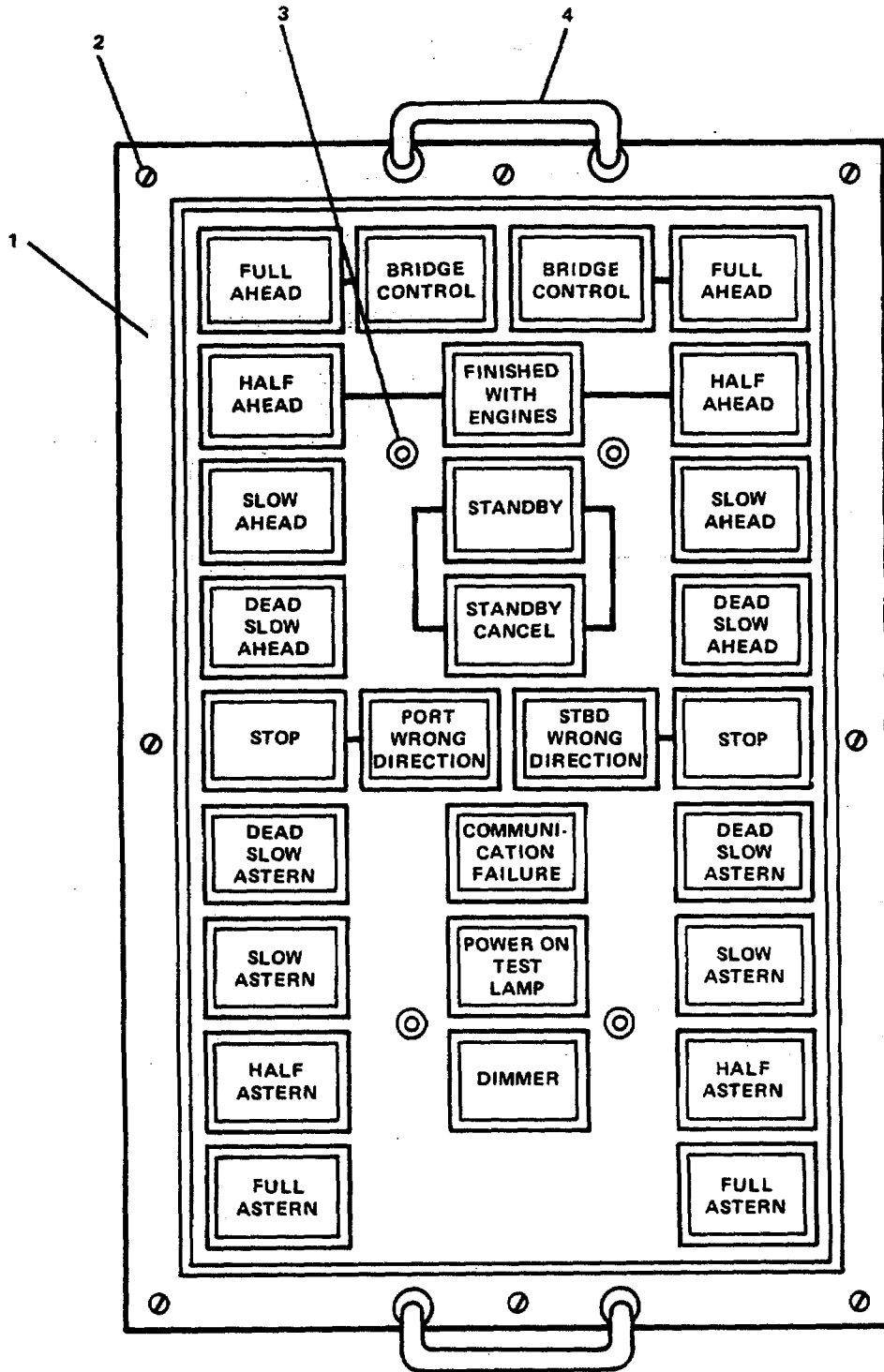

FIGURE 3-122. EOT Bridge Panel Assembly.

---

**3-135. Replace/Repair Bridge Multi-Remove Module. (Figure 3-123)**

---

**This task covers:**

- a. Removal,                      b. Repair,                      f. Replacement**
- 

**INITIAL SETUP:**Tools

Tool kit, electrician's,  
5180-00-391-1087

Equipment Condition

Electrical power to engine order  
telegraph system secured and  
tagged "Out of Service - Do Not  
Operate." (TM 55-1905-223-10).

Materials/Parts

Warning tags, Item 1, Appendix C

---

**REMOVAL**

- a. Loosen captive screws (1) and open cover (2).
- b. Tag and disconnect wiring from terminal boards.
- c. Remove mounting screws (4).
- d. Remove bridge multi-remote module (3).

**REPAIR**

Repair at this level is by replacement of bridge multi-remote module.

**REPLACEMENT**

- a. Mount bridge multi-remote module (3) on bulkhead. Secure with mounting screws (4).
- b. Connect wiring to terminal boards. Remove tags.
- c. Close door (2). Tighten captive screws (1).
- d. Turn power to engine order telegraph system on and remove tags.

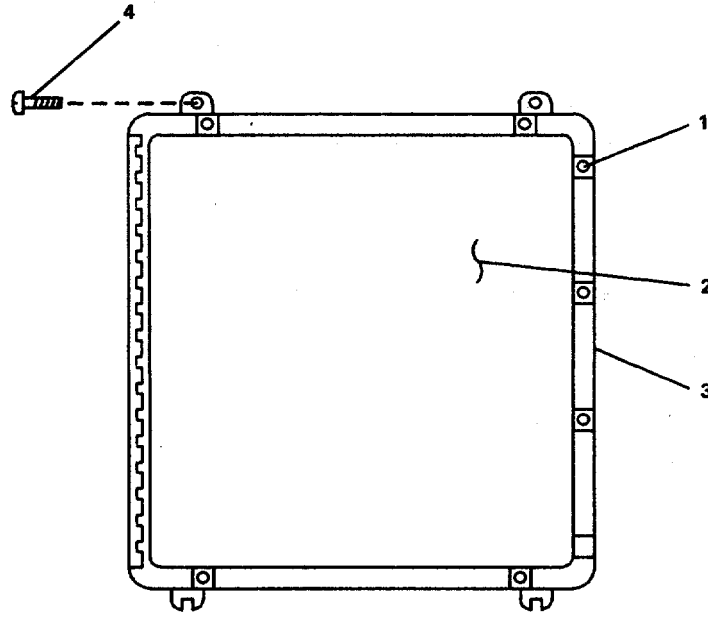

FIGURE 3-123. Bridge Multi-Remote Module.



---

**3-136. Replace/Repair Central Processing Unit. (Figure 3-124)**

---

**This task covers:**

- |                             |                                   |            |
|-----------------------------|-----------------------------------|------------|
| a. Removal,<br>d. Assembly, | b. Disassembly,<br>e. Replacement | c. Repair, |
|-----------------------------|-----------------------------------|------------|
- 

**INITIAL SETUP:**Tools

Tool kit, electrician's,  
5180-00-391-1087

Equipment Condition

Electrical power to engine order  
telegraph system secured and  
tagged "Out of Service - Do Not  
Operate." (TM 55-1905-223-10)

Materials/Parts

Printed circuit board  
P/N 05-09601-000  
Printed circuit board  
P/N 05-09506-000  
Printed circuit board  
P/N 05-09502-000  
Warning Tags, Item 1, Appendix C

---

**REMOVAL**

- a. Loosen captive screw (1) and open cover (2) on enclosure (3).
- b. Tag and disconnect electrical leads.
- c. Remove central processing unit (5).

**DISASSEMBLY**

- a. Remove printed circuit boards (6).
- b. Tag and remove electrical power cable (4).

**REPAIR**

Repair at this level of maintenance is by replacement of printed circuit boards (6).

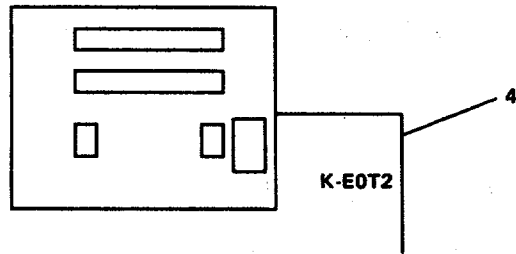
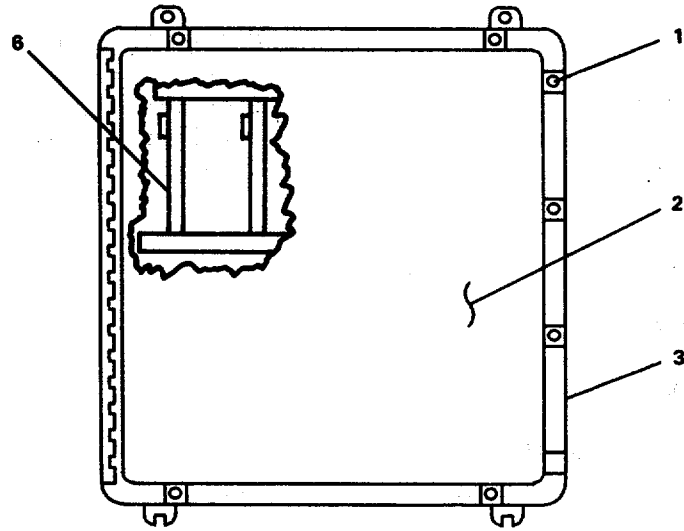

(MOUNTED INSIDE CONSOLE)

FIGURE 3-124. Central Processing Unit.

**ASSEMBLY**

- a. Remove tag and connect electrical power cable (4).
- b. Install printed circuit boards (6).

**REPLACEMENT**

- a. Install central processing unit (3).
- b. Remove tags and connect electrical leads.
- c. Close cover (2) on enclosure (3) and tighten captive screws (1).

---

**3-137. Replace/Repair Engine Room Multi-Remote Module. (Figure 3-125)**

---

**This task covers:**

- a. Removal,                      b. Repair,                      f. Replacement**
- 

**INITIAL SETUP:**Tools

Tool kit, electrician's,  
5180-00-391-1087

Equipment Condition

Electrical power to engine order  
telegraph system secured and  
tagged "Out of Service - Do Not  
Operate." (TM 55-1905-223-10)

Materials/Parts

Warning tag, Item 1, Appendix C

---

**REMOVAL**

- a. Loosen captive screws (1) and open cover (2) on enclosure (3).
- b. Tag and disconnect electrical leads.
- c. Remove engine room multi-remote module (4).
- d. Tag and remove electrical power cable (16) from digital indicator (17).
- e. Tag and remove electrical power cable (18) from digital indicator (19).
- f. Tag and disconnect electrical power cable (5) from liquid level switch (6).
- g. Tag and disconnect electrical power cable (7) from liquid level switch (8).
- h. Tag and disconnect electrical power cable (23) from S.S. SWBD (22).
- i. Tag and disconnect electrical power cable (20) from BTRY (21).
- J. Tag and disconnect electrical power cables (9, 10, 11).
- k. Tag and disconnect electrical power cable (14) from A7 (15).
- l. Tag and disconnect electrical power cable (13) from CPU (12).

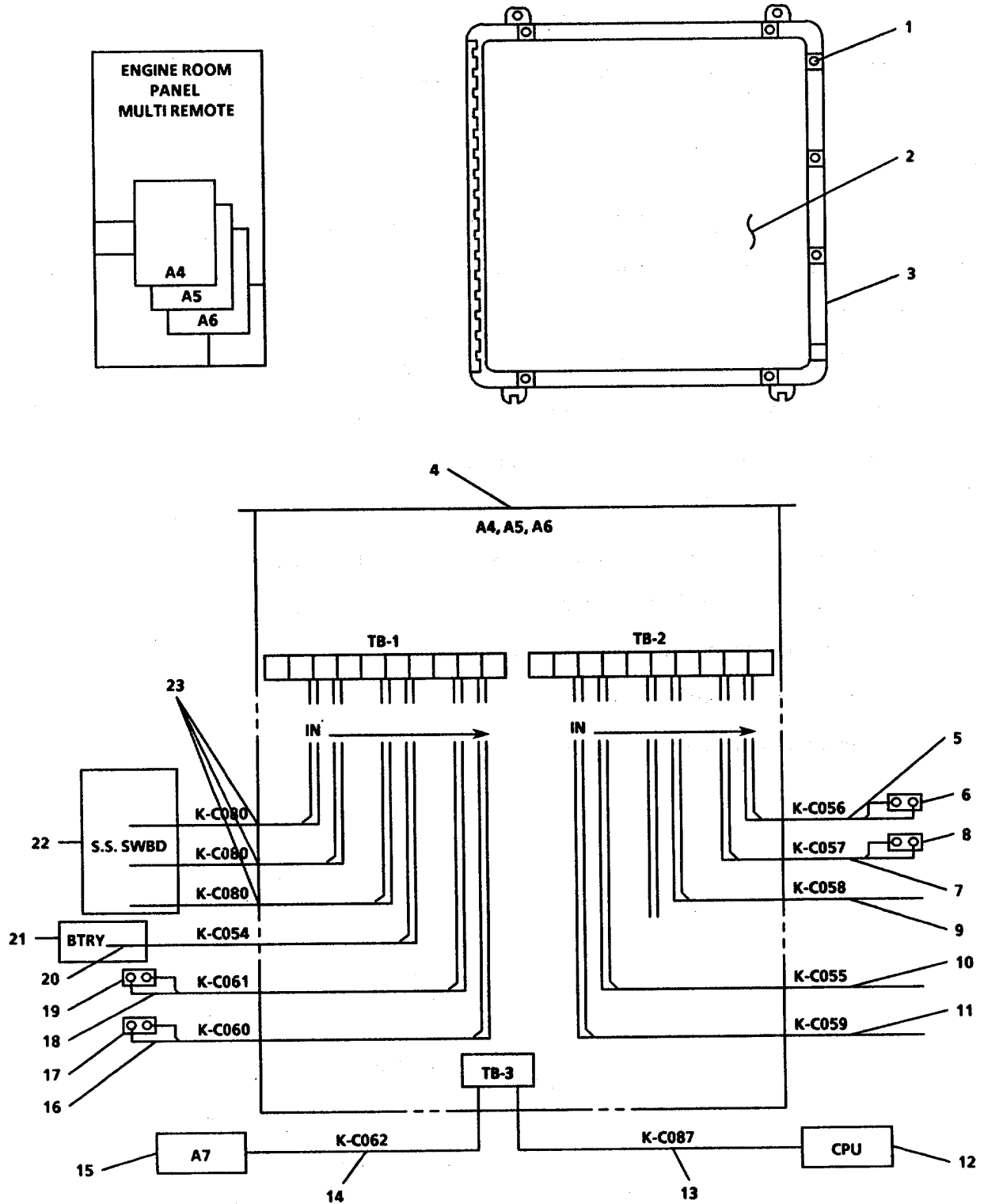

FIGURE 3-125. Engine Room Multi-Remote Module.

## REPAIR

Repair at this level of maintenance is by replacement of engine room multi-remote module (4) and cables.

## REPLACEMENT

- a. Remove tag and connect electrical power cable (13) to CPU (12).
- b. Remove tag and connect electrical power cable (14) to A7 (15).
- c. Remove tag and connect electrical power cables (9, 10, 11).
- d. Remove tag and connect electrical power cable (20) to BTRY (21).
- e. Remove tag and connect electrical power cable (23) to S.S. SWBD (22).
- f. Remove tag and connect electrical power cable (7) to liquid level switch (8).
- g. Remove tag and connect electrical power cable (5) to liquid level switch (6).
- h. Remove tag and connect electrical power cable (18) to digital indicator (19).
- i. Remove tag and connect electrical power cable (16) to digital indicator (17).
- j. Install engine room multi-remote module (4).
- k. Remove tags and connect electrical lead.
- l. Close cover (2) on enclosure (3) and tighten captive screws (1).

---

**3-138. Replace/Repair Engine Room Panel Assembly. (Figure 3-126)**

---

**This task covers:**

- a. Removal,                      b. Repair,                      f. Replacement**
- 

**INITIAL SETUP:**Tools

Tool kit, electrician's  
5180-00-391-1087

Equipment Condition

Electrical power to engine order  
telegraph system secured and tagged  
"Out of Service - Do Not Operate."  
(TM 55-1905-223-10)

Materials/Parts

Warning tags, Item 1, Appendix C

---

**REMOVAL**

- a. Remove eight round head screws (2).
- b. Remove four allen head screws (3).
- c. Grasp handles (4) and carefully pull panel (1) upward until electrical leads are accessible.
- d. Tag and disconnect electrical leads to 28 push switches.

**REPAIR**

Repair at this level of maintenance is by replacement of the panel assembly.

**REPLACEMENT**

- a. Connect electrical leads to 28 push switches and remove tags.
- b. Grasp handles (4) and insert engine room panel assembly (1) into engine room control console.
- c. Secure with four allen head screws (3) and eight round head screws (2).
- d. Restore power to panel and remove tags.
- e. Press POWER ON LAMP TEST to ensure indicators are working properly.

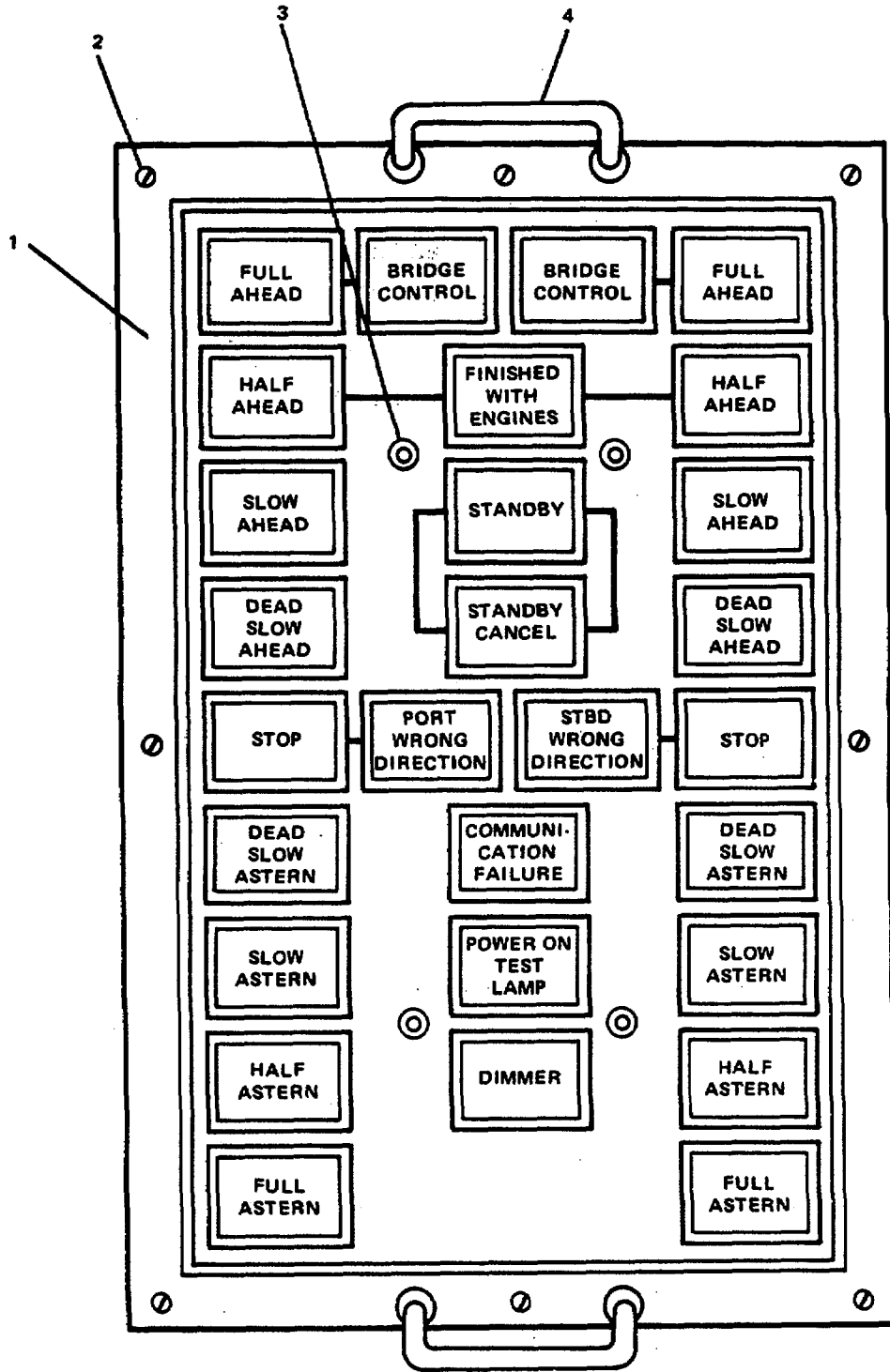

FIGURE 3-126. *EOT Engine Room Panel Assembly.*





---

**3-140. Replace/Repair Fire Detection Control Panel with Thermostats.**

---

**This task covers:**

- a. Removal,                      b. Disassembly,                      c. Repair,**
- 

**INITIAL SETUP:**

Tools

Tool kit, electrician's,  
5180-00-391-1087

Materials/Parts

Power supply P/N PS-35  
Voltmeter (meter module) P/N MM-35  
Zone module (3) P/N ZU-35TS  
Storage battery P/N BM-31  
Electrical bell P/N BDC-624  
Power transformer (isolation)  
P/N 7450-1.55  
Power transformer (battery charger  
transfer) P/N BC-35  
Warning tags, Item 1, Appendix C

Equipment Condition

Notify Vessel Master.  
Secure power to fire detection  
control panel at EP102, circuit  
breaker 16.  
Disconnect battery inside fire  
detection control panel.  
Tag "Out of Service - Do Not Operate."  
(TM 55-1905-223-10)

---

**WARNING**

Notify the bridge that the fire detection system will be secured  
for an extended period of time for maintenance.

**REMOVAL**

- a. Tag and disconnect electrical cables (5, 14, 15, and 16, Sheet 1).
- b. Remove 12 mounting screws (3).
- c. Remove fire detection control panel (1).

**DISASSEMBLY**

- a. Tag and disconnect electrical cables (9) to power transformer (8).

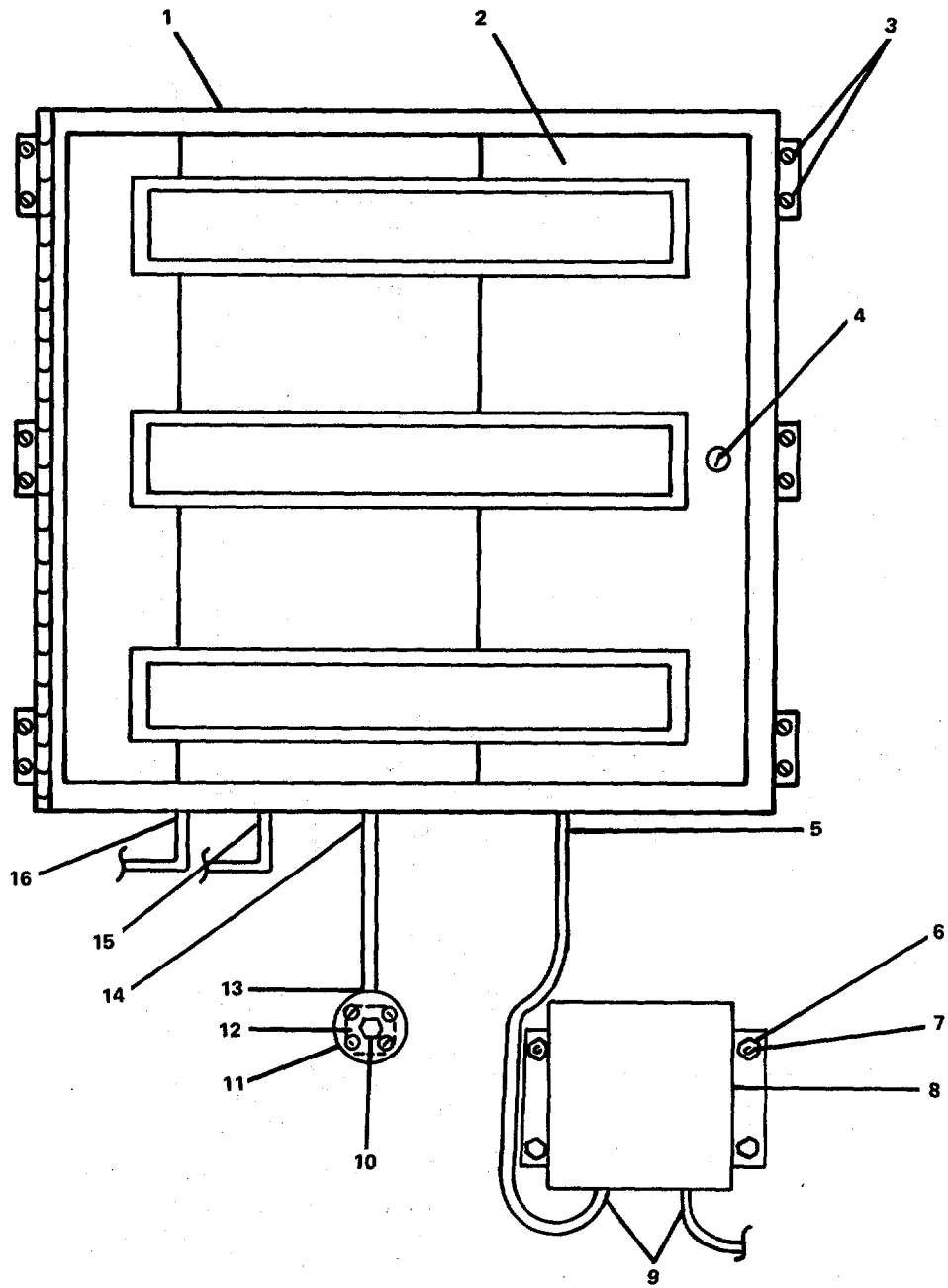

FIGURE 3-127. Fire Detection Control Panel (Sheet 1 of 2).

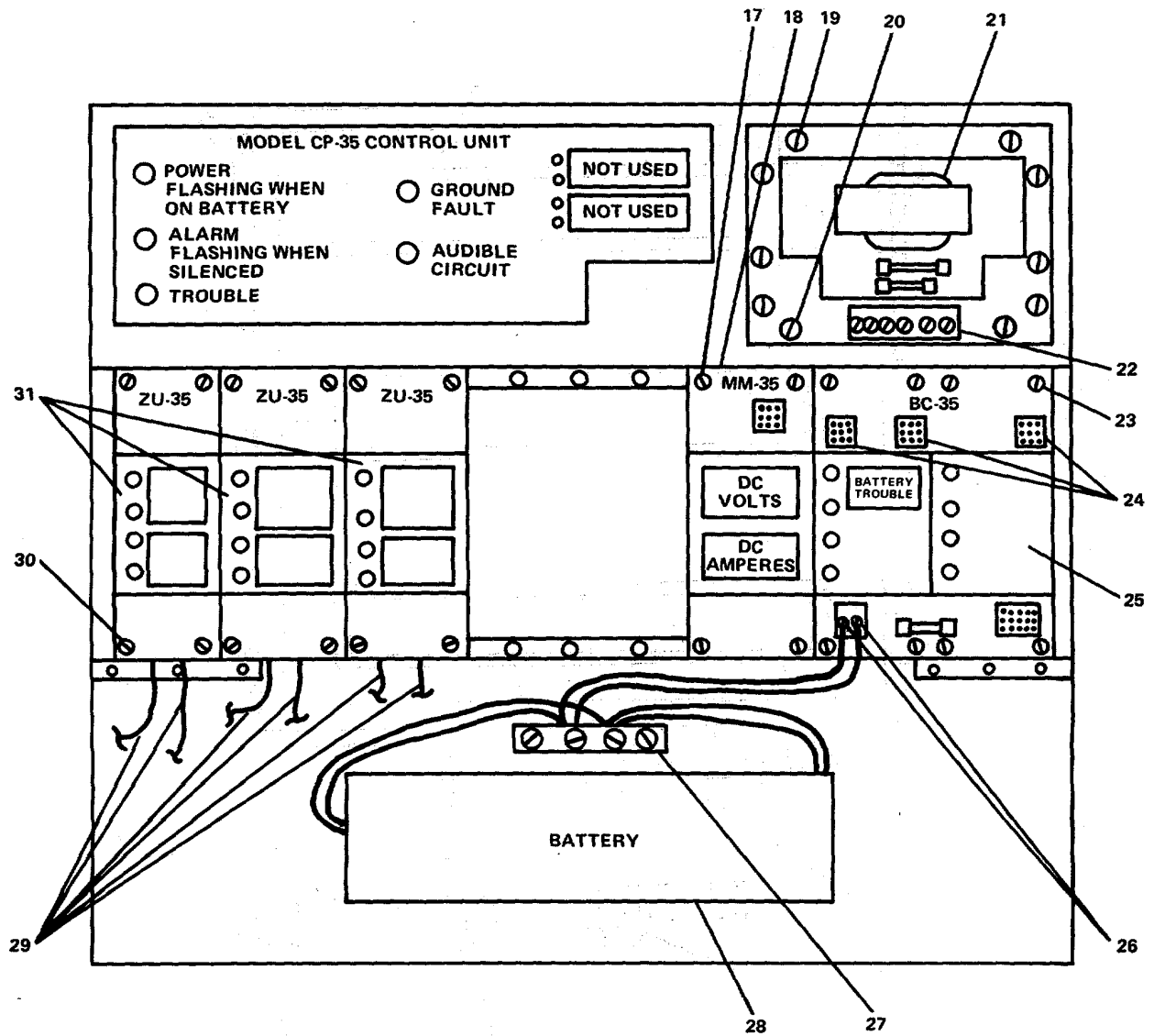

FIGURE 3-127. Fire Detection Control Panel (Sheet 2, of 2).

- b. Remove hex head nuts (6) from mounting studs (7).
- c. Remove power transformer (8).
- d. Disconnect electrical cable (13) to electrical bell (11).
- e. Remove hex head screw (10).
- f. Remove electrical bell (11) from mounting bracket (12).
- g. Insert key in keyhole (4) and open door (2).
- h. Unplug electrical plug (19) from voltmeter (meter module) (18, Sheet 2).
- i. Remove four retaining screws (17).
- j. Remove meter module (18).
- k. Tag and disconnect electrical leads to terminal board (22).
- l. Remove ten retaining screws (20).
- m. Remove power supply (21).
- n. Unplug electrical plugs (24) from power transformer (battery charger transfer) (25).
- o. Remove eight retaining screws (23).
- p. Remove power transformer (25).
- q. Tag and disconnect electrical leads at terminal blocks (26, 27).
- r. Remove storage battery (28).
- s. Tag and disconnect electrical leads (29) to zone modules (31).
- t. Remove 12 retaining screws (30).
- u. Remove zone modules (31).

---

**REPAIR**

Repair at this level of maintenance is by replacement of power transformer (isolation) (8), electrical bell (11), voltmeter (meter module) (18), power supply (21), power transformer (battery charger transfer) (25), storage battery (28), and zone modules (31, Sheets 1 and 2).

**ASSEMBLY**

- a. Install zone modules (31) and secure with 12 retaining screws (30, Sheet 2).
- b. Connect electrical leads (29) to zone modules. Remove tags.
- c. Replace storage battery (28).
- d. Connect electrical leads at terminal blocks (26, 27).
- e. Install power transformer (battery charger transfer) (25) and secure with eight retaining screws (23).
- f. Plug-in electrical plugs (24).
- g. Install power supply (21) and secure with ten retaining screws (20).
- h. Connect electrical leads at terminal board (22). Remove tags.
- i. Install voltmeter (meter module) (18) and secure with four retaining screws (17).
- j. Plug-in electrical plug (19).
- k. Insert key in keyhole (4) and close and lock door (2, Sheet 1).
- l. Install electrical bell (11) on mounting bracket (12). Replace hex head screw (10).
- m. Connect electrical cable (13) to bell.
- n. Install power transformer (isolation) (8) on mounting studs (7).
- o. Secure with hex head nuts (6).
- p. Connect electrical cables (9) to power transformer. Remove tags.

**WARNING**

To prevent personal injury from the weight of the panel, two soldiers are required for this procedure.

**REPLACEMENT**

- a. Position fire detection control panel (1) on bulkhead (sheet 1).
- b. Secure with 12 mounting screws (3).
- c. Connect electrical cables (5, 14, 15, and 16). Remove tags.
- d. Turn circuit breaker 16 on in EP102. Remove tags.
- e. Notify the bridge that maintenance on the fire detection system is complete.

---

**3-141. Replace/Repair Shipboard Alarm Panel. (Figure 3-128)**

---

This task covers:

a. Removal

b. Repair

c. Replacement

---

**INITIAL SETUP:****Tools**

Tool kit, electrician's,  
5180-00-391-1087

**Materials/Parts**

Warning tags, Item 1, Appendix C

**Equipment Condition**

Electrical power to shipboard alarm panel secured and tagged "Out of Service - Do Not Operate."  
(TM 55-1905-223-10)

---

---

**WARNING**

---

Notify the bridge that the shipboard alarm system will be secured for an extended period of time for maintenance.

**REMOVAL**

- a. Tag and disconnect electrical power cables (3, 4).
- b. Remove two mounting screws (2).
- c. Remove shipboard alarm panel (1) from bulkhead.

**REPAIR**

Repair at this level of maintenance is by replacement of shipboard alarm panel (1).

**REPLACEMENT**

- a. Position shipboard alarm panel (1) on bulkhead.
- b. Secure with two mounting screws (2).
- c. Connect electrical power cables (3, 4). Remove tags.
- d. Restore power to shipboard alarm panel. Remove tags.
- e. Notify bridge that maintenance on the shipboard alarm panel is complete.

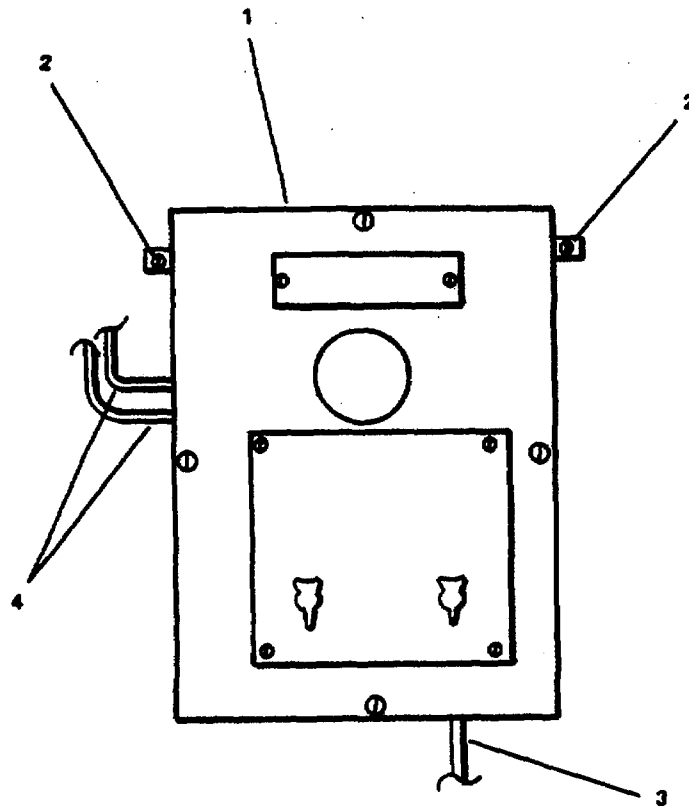

FIGURE 3-128. *Shipboard Alarm Panel.*



**MAINTENANCE OF ELECTRICAL SYSTEM**

---

**3-142. Repair 240V Power Distribution.**

---

**This task covers:**

- a. Repair**
- 

Repair of 240V Power Distribution is by replacement/repair of the components in the power distribution system. Refer to paragraphs 3-143 through 3-164 .

---

**3-143. Repair Power Distribution Panel P201. (Figure 3-129)**

---

**This task covers:**  
**Repair**

---

**INITIAL SETUP:**Tools

Tool kit, electrician's,  
5180-00-391-1087

Materials/Parts

Warning tag, Item 1, Appendix C

---

Equipment Condition

Main switchboard FWD HDR POWER PANEL  
P201 175AT circuit breaker OFF and  
tagged "Out of Service - Do Not  
Operate." TM 55-1905-223-10.

---

**WARNING**

Death, serious injury, or equipment damage can result from contact with live electrical circuits. Before beginning work on this, or any other electrical equipment, turn power and control voltage circuit breakers OFF and tag "Out of Service - Do Not Operate."

---

**REPAIR****NOTE**

Repair of power distribution panel P201 (7) is by replacement of associated electrical cables (1 through 6).

- a. Disconnect cable (1 through 6) from power distribution panel and termination point.
- b. Run new cable. Attach to power distribution panel and termination point.

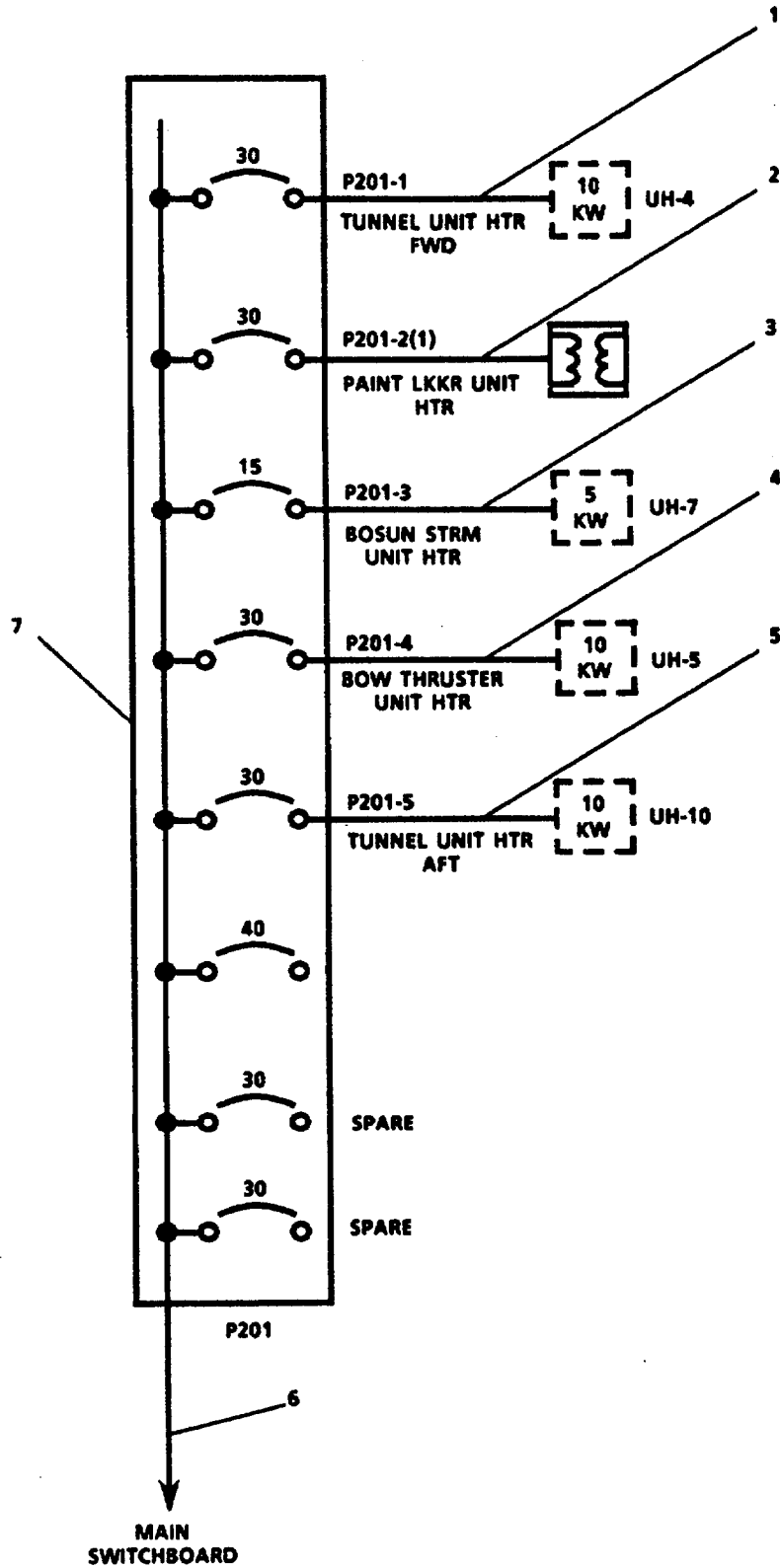

FIGURE 3-129. Power Distribution Panel (P201).

---

**3-144. Repair Power Distribution Panel, Galley P202. (Figure 3-130)**

---

**This task covers:**  
**Repair**

---

**INITIAL SETUP:****Tools**

Tool kit, electrician's,  
5180-00-391-1087

**Materials/Parts**

Warning tags, Item 1, Appendix C

---

**Equipment Condition**

Main switchboard GALLEY POWER PANEL  
P202 250AT circuit breaker OFF and  
tagged "Out of Service - Do Not  
Operate." TM 55-1905-223-10.

---

**WARNING**

Death, serious injury or equipment damage can result from contact with live electrical circuits. -Before beginning work on this, or any other electrical equipment, turn power and control voltage circuit breakers OFF and tag "Out of Service - Do Not Operate."

**REPAIR****NOTE**

Repair of power distribution panel P202 (10) is by replacement of associated electrical cables (1 through 9).

- a. Disconnect cable (1 through 9) from power distribution panel and termination point.
- b. Run new cable. Attach to power distribution panel and termination point.

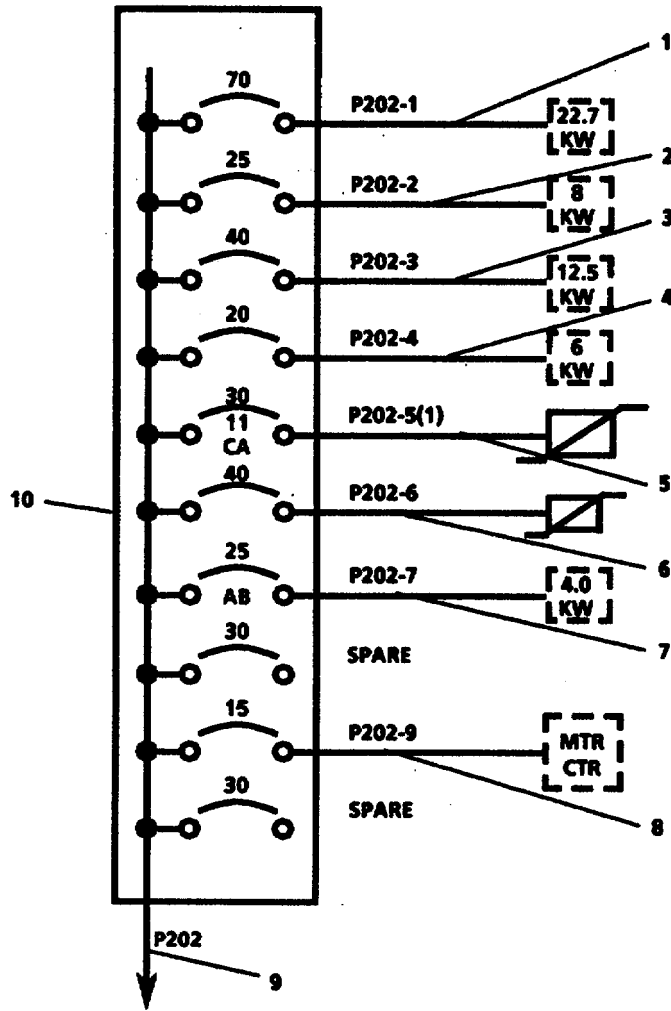

FIGURE 3-130. Power Distribution Panel. Galley (P202).

---

**3-145. Repair Power Distribution Panel P203. (Figure 3-131)**

---

**This task covers:**  
**Repair**

---

**INITIAL SETUP:****Tools**

Tool kit, electrician's,  
5180-00-391-1087

**Materials/Parts**

Warning tag, Item 1, Appendix C

---

**Equipment Condition**

Main switchboard MCHRY SPACES HTR PWR  
PNL P203 150AT circuit breaker OFF  
and tagged "Out of Service - Do Not  
Operate." TM 55-1905-223.10.

---

**WARNING**

---

Death, serious injury, or equipment damage can result from contact with live electrical circuits. Before beginning work on this, or any other electrical equipment, turn power and control voltage circuit breakers OFF and tag "Out of Service - Do Not Operate."

---

**REPAIR****NOTE**

Repair of power distribution panel P204 (9) is by replacement of associated electrical cables (1 through 8).

- a. Disconnect cable (1 through 8) from power distribution panel and termination point.
- b. Run new cable. Attach to power distribution panel and termination point.

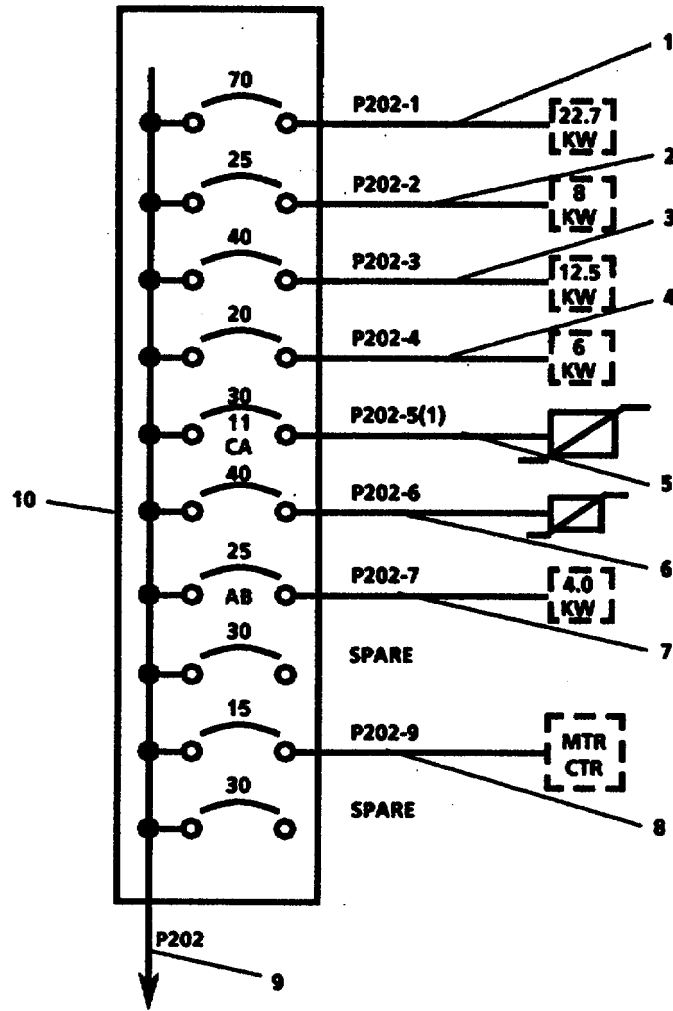

FIGURE 3-131. Power Distribution Panel (P203).

---

**3-146. Repair Power Distribution Panel P204. (Figure 3-132)**

---

**This task covers:**  
**Repair**

---

**INITIAL SETUP:****Tools**

Tool kit, electrician's,  
5180-00-391-1087

**Materials/Parts**

Warning tag, Item 1, Appendix C

---

**Equipment Condition**

Main switchboard MISC MCHRY POWER PANEL  
P204 60AT circuit breaker OFF and  
tagged "Out of Service - Do Not  
Operate." TM 55-1905-223-10.

---

**WARNING**

---

Death, serious injury, or equipment damage can result from contact with live electrical circuits. Before beginning work on this, or any other electrical equipment, turn power and control voltage circuit breakers OFF and tag "Out of Service - Do Not Operate."

---

**REPAIR****NOTE**

Repair of power distribution panel P204 (5) is by replacement of associated electrical cables (1 through 4).

- a. Disconnect cable (1 through 4) from power distribution panel and termination point.
- b. Run new cable. Attach to power distribution panel and termination point.



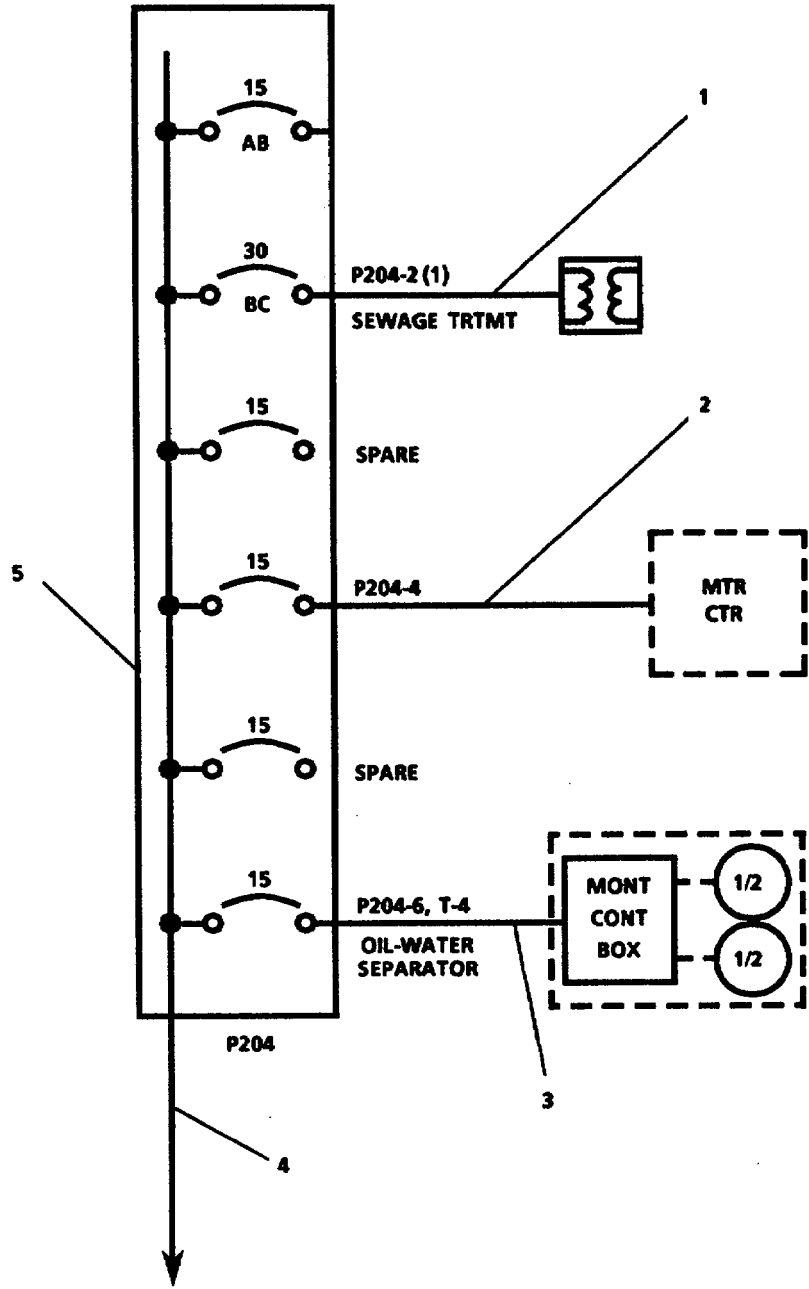

FIGURE 3-132. Power Distribution Panel (P204).



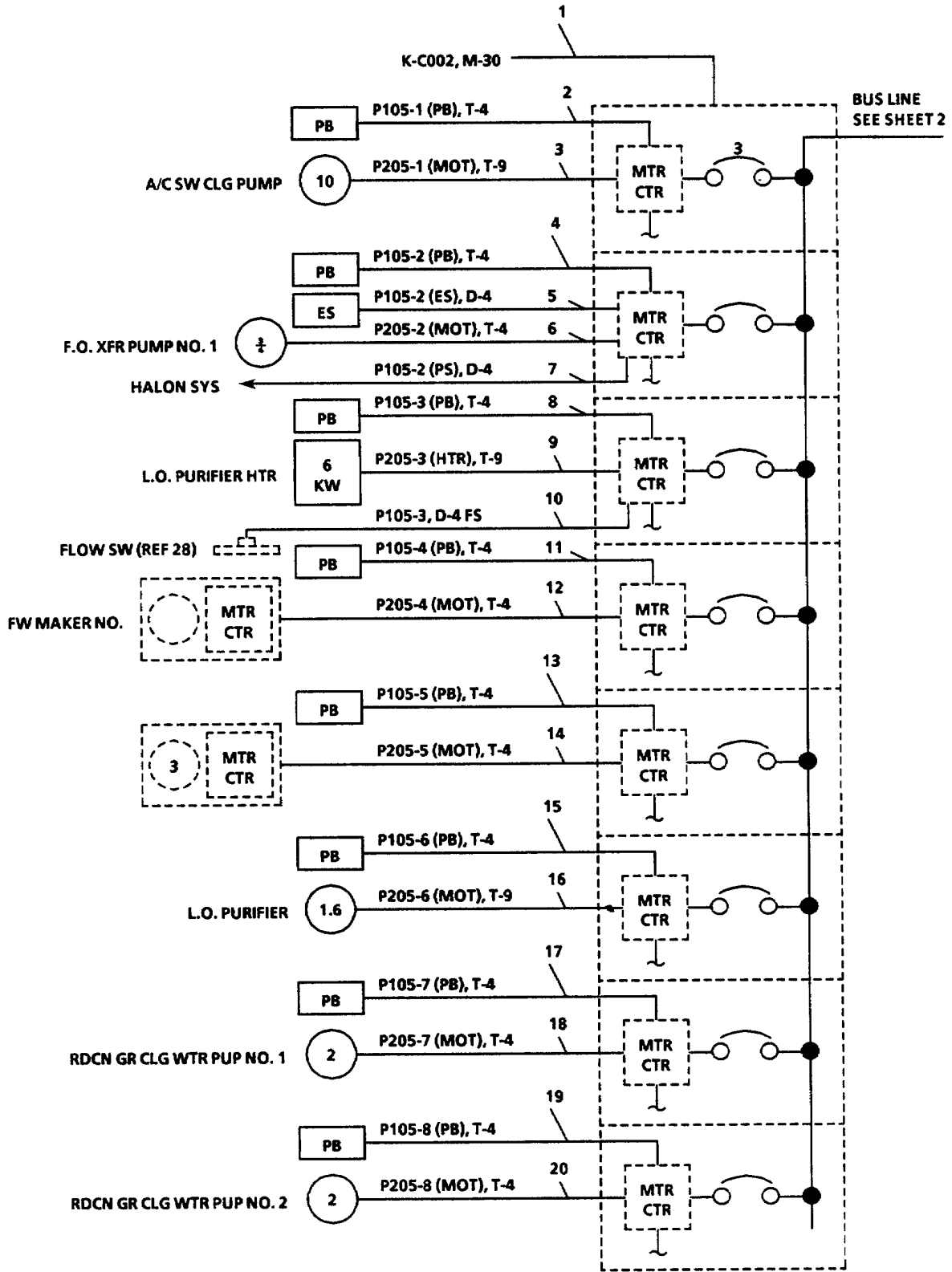

FIGURE 3-133. Auxiliary Machinery Motor Control Center Power Distribution. (Sheet 1 of 2).

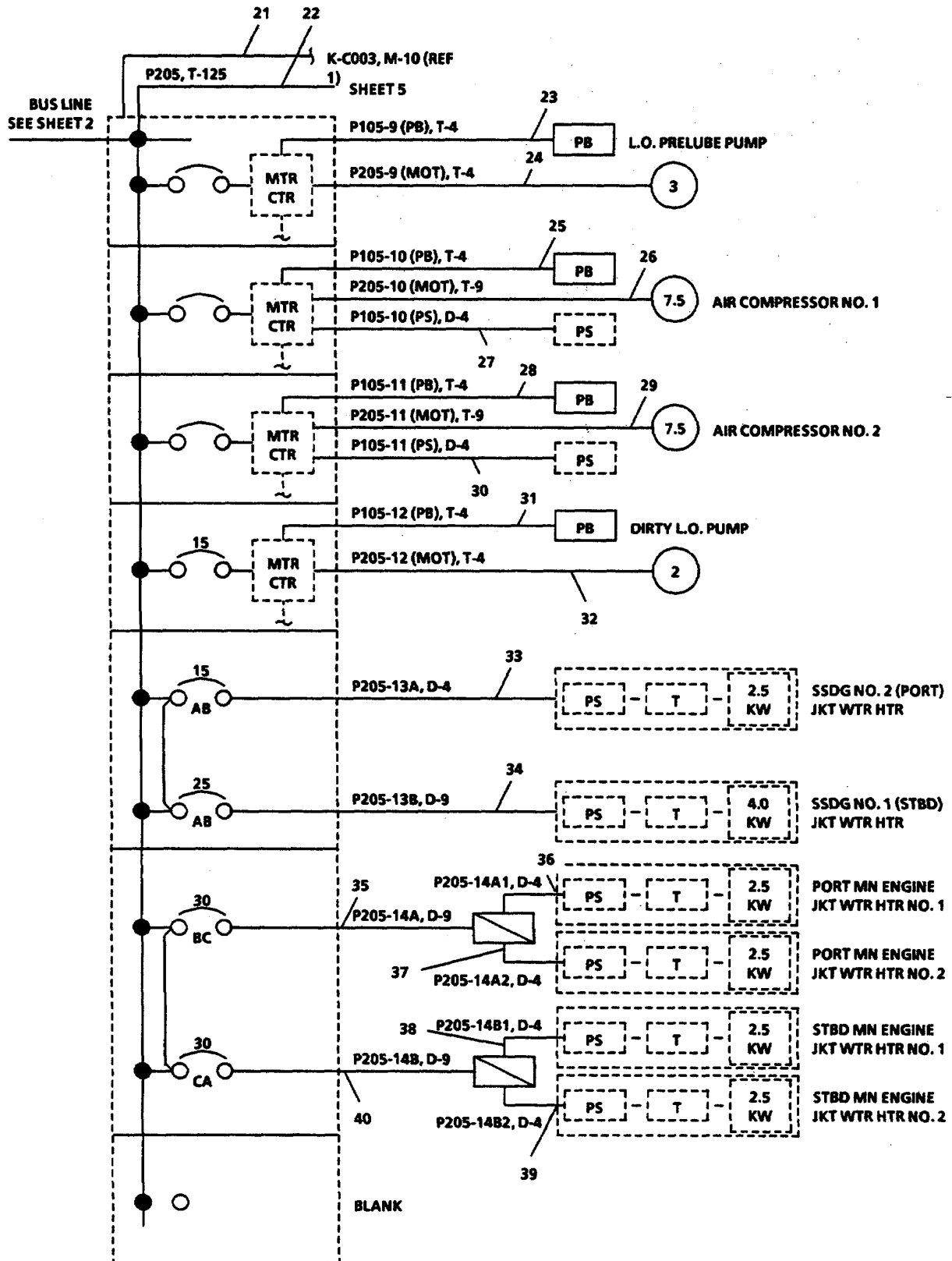

FIGURE 3-133. Auxiliary Machinery Motor Control Center Power Distribution. (Sheet 2 of 2).

---

**3-148. Replace/Repair Forward Deck Machinery Motor Control Center, Power Distribution.**

---

(Figure 3-134)

This task covers:

- a. Removal,                      b. Repair,                      c. Replacement.**
- 

**INITIAL SETUP:**

Tools

Tool kit, electrician's,  
5180-00-391-1087

Equipment Condition

Main switchboard FWD DECK MCHRY MCC  
P206 200AT circuit breaker OFF and  
tagged "Out of Service - Do Not  
Operate." (TM 55-1905-223-10).

Materials/Parts

Warning tags, Item 1, Appendix C

---

**WARNING**

Death, serious injury, or equipment damage can result from contact with live electrical circuits. Before beginning work on this, or any other electrical equipment, turn power and control voltage circuit breakers OFF and tag "Out of Service - Do Not Operate."

**NOTE**

Repair and replacement of motor control centers is covered in the control centers switchboards section of this manual.

**REMOVAL**

- a. Disconnect electrical cable (1 through 16) from motor control center.
- b. Disconnect electrical cable from termination.

**REPAIR**

Repair at this level of maintenance is by replacement of electrical cables.

**REPLACEMENT**

- a. Connect electrical cable (1 through 16) to motor control center.
- b. Connect electrical cable to termination.

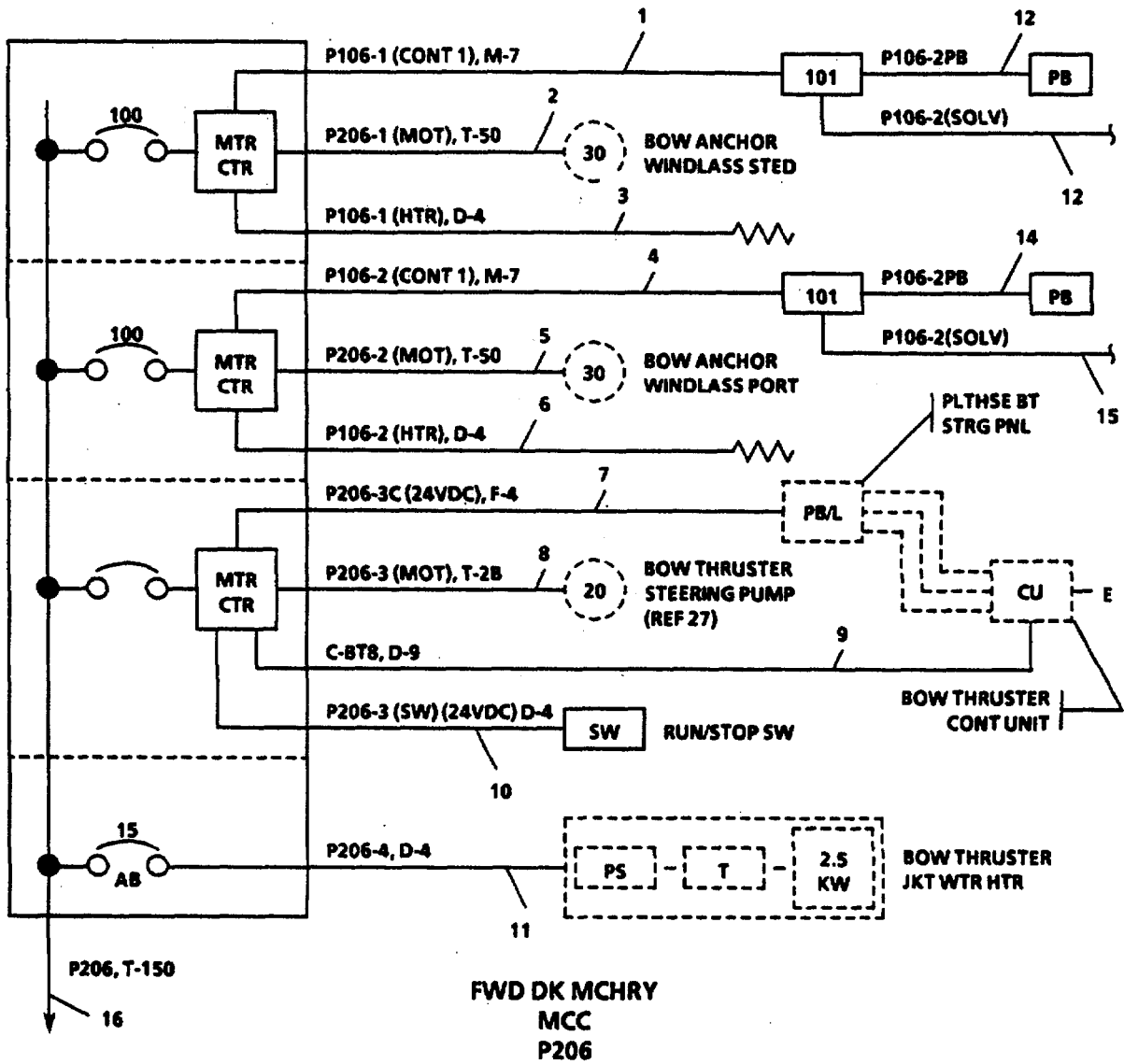

FIGURE 3-134. Forward Deck Machinery Motor Control Center Power Distribution.



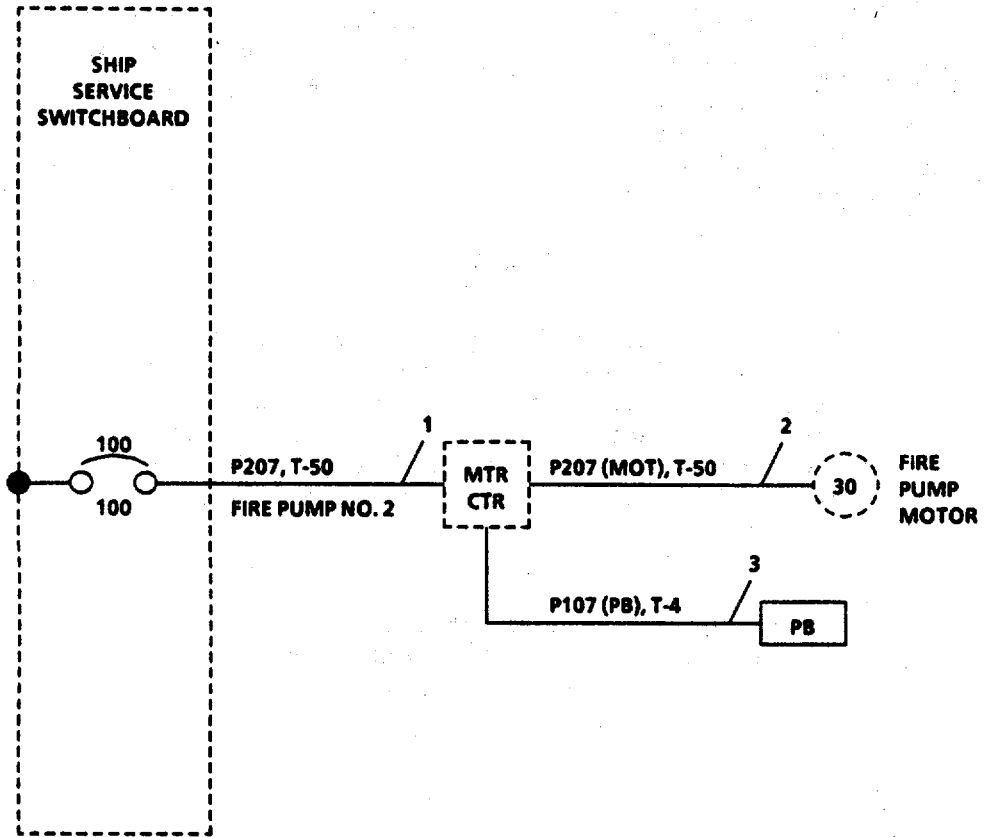

FIGURE 3-135. Fire Pump Number Two Power Distribution.





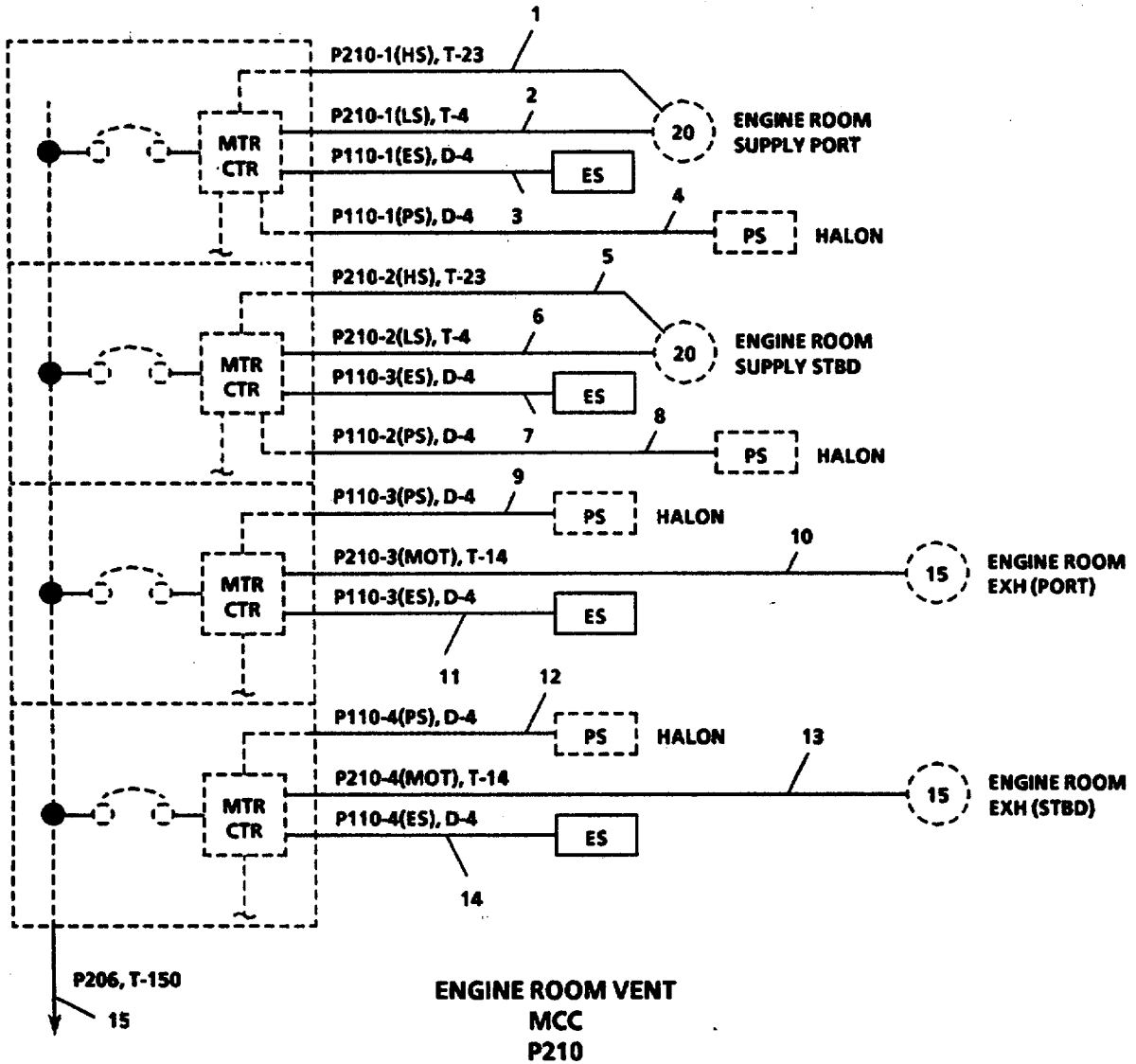

FIGURE 3-136. Engine Room Vent Motor Control Center Power Distribution.

---

**3-151. Repair Power Distribution Panel P211. (Figure 3-137)**

---

**This task covers:****a. Removal****b. Repair****c. Replacement**

---

**INITIAL SETUP:**ToolsTool kit, electrician's,  
5180-00-391-1087Materials Parts

Warning tag, Item 1, Appendix C

Equipment ConditionMain switchboard MCHRY SPACES VENT  
PANEL P211 125AT/UVT circuit breaker  
OFF and tagged "Out of Service - Do  
Not Operate." TM 55-1905-223-10.

---

**WARNING**

Death, serious injury, or equipment damage can result from contact with live electrical circuits. Before beginning work on this, or any other electrical equipment, turn power and control voltage circuit breakers OFF and tag "Out of Service - Do Not Operate."

**REPAIR****NOTE**

Repair of power distribution panel P211 is by replacement of associated electrical cables (1 through 13).

- a. Disconnect cable (1 through 13) from power distribution panel and termination point.
- b. Run new cable (1 through 13). Attach to power distribution panel and termination point.

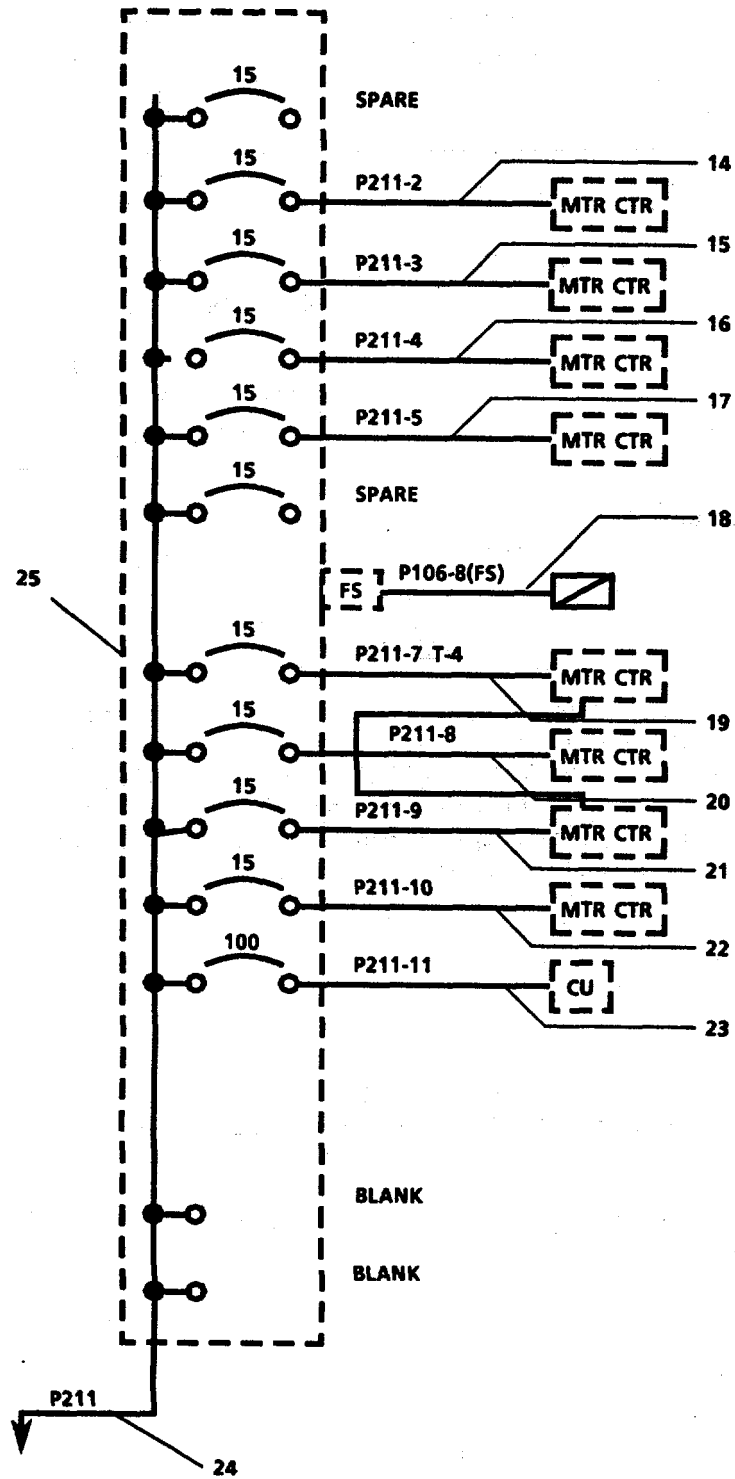

FIGURE 3-137. Power Distribution Panel (P211).

**3-152. Replace/Repair Pilothouse Air Condition Power Distribution.  
(Figure 3-138)**

**This task covers:**

**a. Removal**

**b. Repair**

**c. Replacement**

**INITIAL SETUP:**

Tools

Tool kit, electrician's,  
5180-00-391-1087

Materials/Parts

Warning tag, Item 1, Appendix C

Equipment Condition

Electrical power secured to ship  
service switchboard 240V distribution  
and tagged "Out of Service - Do Not  
Operate."

**WARNING**

Death, serious injury, or equipment damage can result from contact with live electrical circuits. Before beginning work on this, or any other electrical equipment, turn power and control voltage circuit breakers OFF and tag "Out of Service - Do Not Operate."

**REMOVAL**

- a. Disconnect electrical power cable (P213) (F9) (2, Sheet 1) from ship service switchboard (1) and AC-2 (3). Remove cable.
- b. Tag and disconnect electrical power cable (P113) (CONT) (4).
- c. Tag and disconnect electrical power cable (P113) (Thermo) (AC) (F-4) (5) from thermostat (6).
- d. Remove cover (9) and mounting screw (8, Sheet 2).
- e. Remove thermostat (7).

**REPAIR**

Repair at this level of maintenance is by replacement of worn or defective parts.

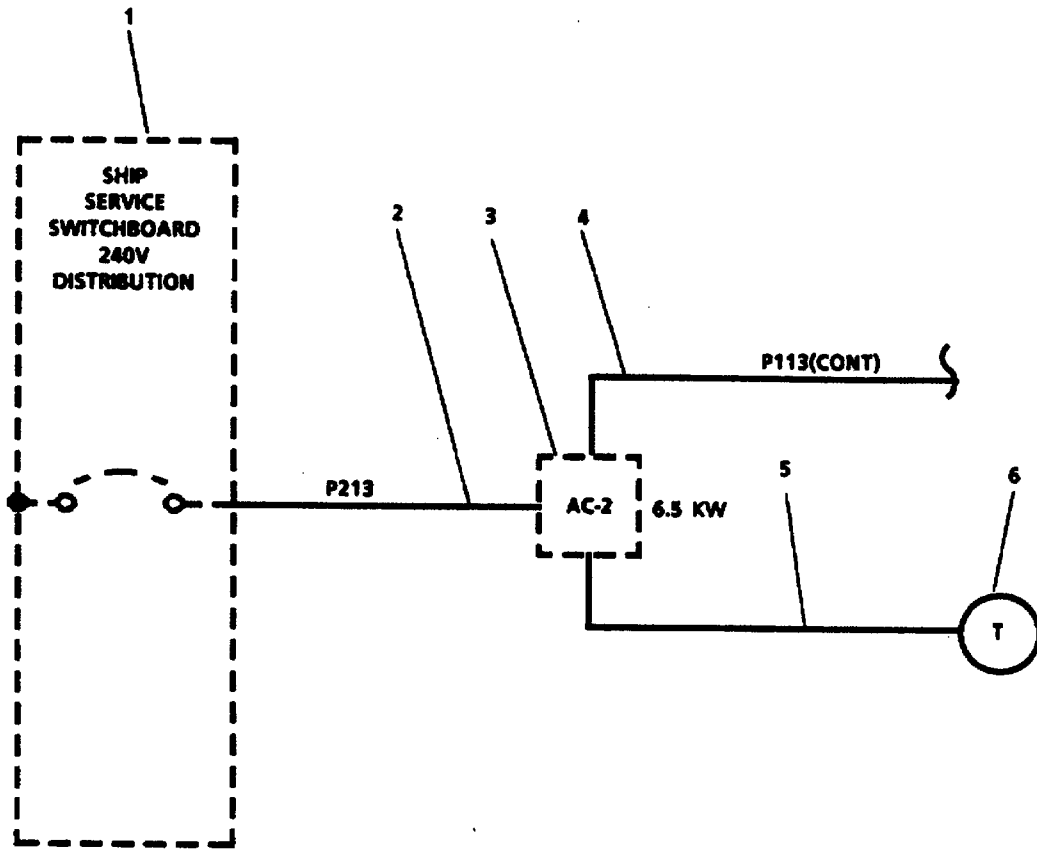

FIGURE 3-138. *Pilothouse Air Condition Power Distribution (Sheet 1 of 2).*

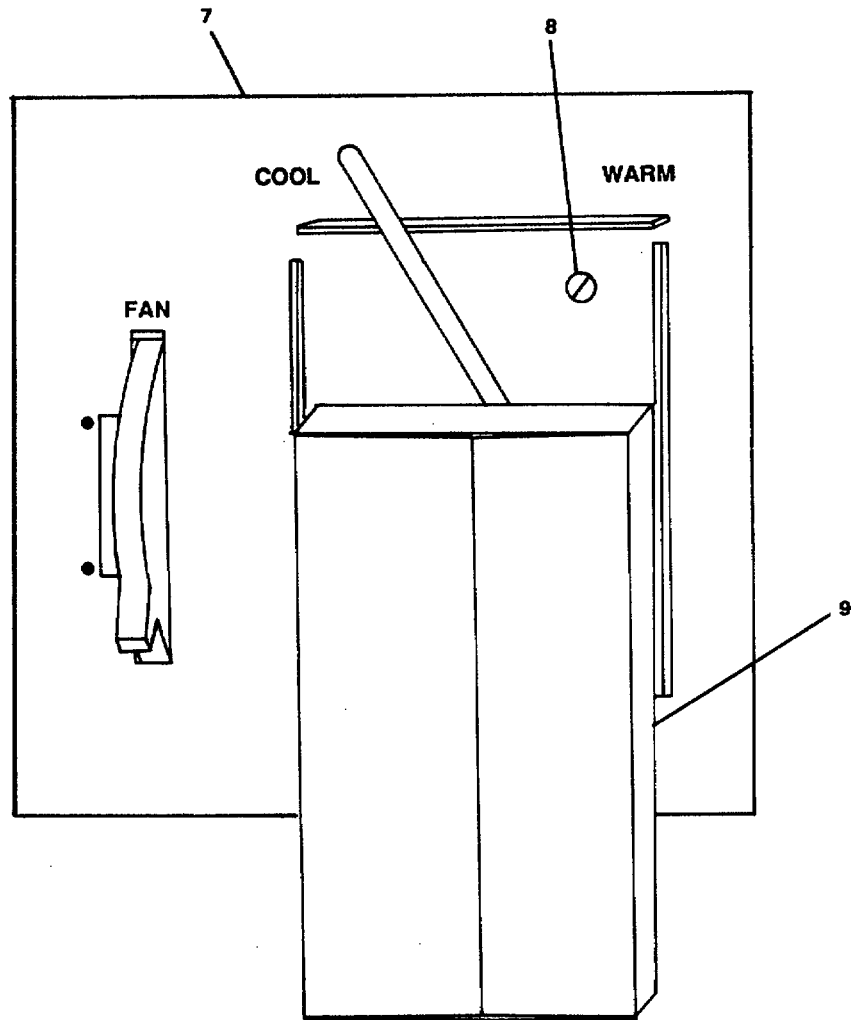

FIGURE 3-138. *Pilothouse Air Condition Power Distribution-(Sheet 2 of 2).*

## REPLACEMENT

- a. Install thermostat (7, Sheet 2).
- b. Install mounting screw (8) and cover (9).
- c. Remove tag and connect electrical power cable (P113) (thermo) (AC) (F-4) (5) to thermostat (Sheet 1).
- d. Remove tag and connect electrical power cable (P113) (CONT) (4).
- e. Install electrical power cable (P213) (F9) (2) to ship service switchboard (1) and AC-2(3). Connect cable.



**3-153. Replace/Repair Accommodation Air Condition Power Distribution.  
(Figure 3-139)**

**This task covers:**

**a. Removal**

**b. Repair**

**c. Replacement**

**INITIAL SETUP:**

Tools

Tool kit, electrician's,  
5180-00-391-1087

Materials/Parts

Warning tag, Item 1, Appendix C

Equipment Condition

Electrical power secured to ship  
service switchboard 240V distribution  
and tagged "Out of Service - Do Not  
Operate."

**WARNING**

Death, serious injury, or equipment damage can result from contact with live electrical circuits. Before beginning work on this, or any other electrical equipment, turn power and control voltage circuit breakers OFF and tag "Out of Service - Do Not Operate."

**REMOVAL**

Disconnect electrical power cable (P214) (T-50) (2) from ship service switchboard (1) and accommodation air conditioner (3).

**REPAIR**

Repair at this level of maintenance is by replacement electrical cables.

**REPLACEMENT**

Connect electrical power cable (P214) (T-50) (2) to accommodation air conditioner (3) and ship service switchboard (1).

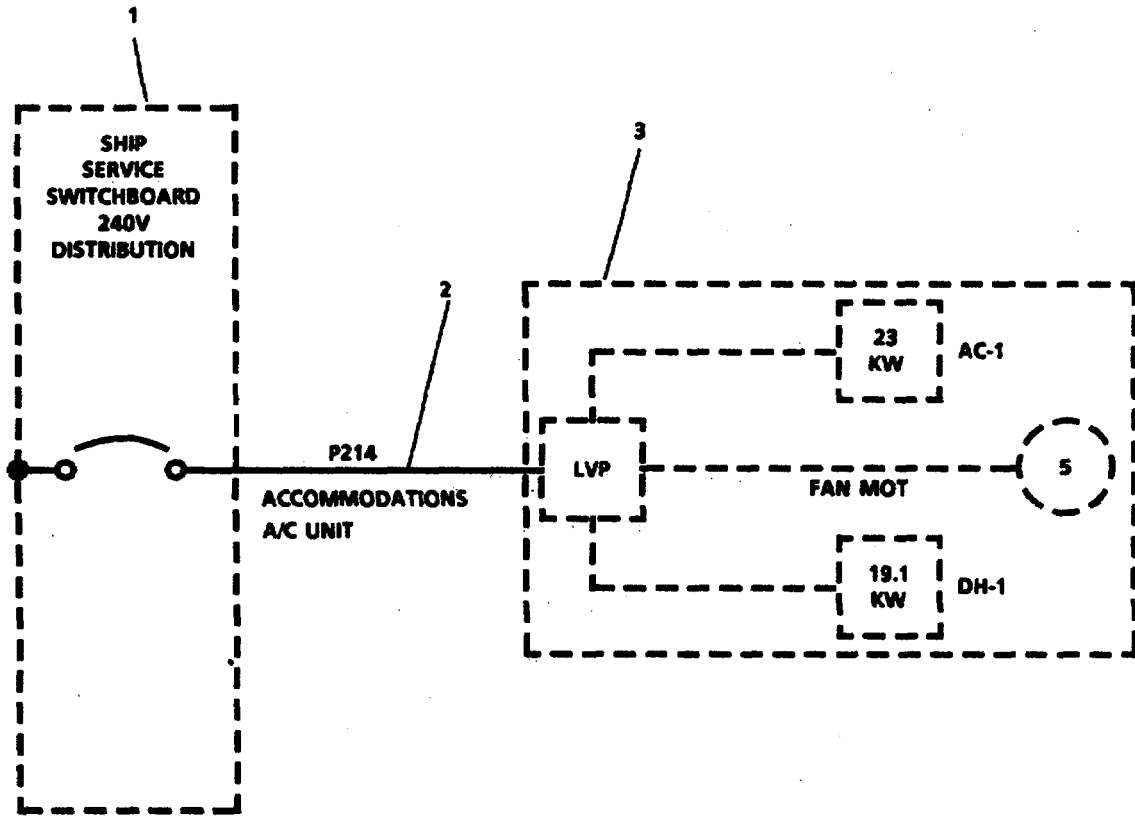

FIGURE 3-139. Accommodation Air Condition Power Distribution.

---

### 3-154. Replace/Repair Engine Room Air Condition Power Distribution. (Figure 3-140)

---

**This task covers:**

**a. Removal**

**b. Repair**

**c. Replacement**

---

#### INITIAL SETUP:

##### Tools

Tool kit, electrician's,  
5180-00-391-1087

##### Materials/Parts

Warning tag, Item 1, Appendix C

---

##### Equipment Condition

Electrical power secured to ship  
service switchboard 240V distribution  
and tagged "Out of Service - Do Not  
Operate.'

### **WARNING**

Death, serious injury, or equipment damage can result from contact with live electrical circuits. Before beginning work on this, or any other electrical equipment, turn power and control voltage circuit breakers OFF and tag "Out of Service - Do Not Operate.'

### **REMOVAL**

- a. Disconnect electrical power cable (P215) (F9) (2, Sheet 1) from ship service switchboard (1) and AC-3 (3). Remove cable.
- b. Tag and disconnect electrical power cable (P115) (CONT) (4).
- c. Tag and disconnect electrical power cable (P115) (Thermo) (F-4) (5) from thermostat (6).
- d. Remove cover (9) and mounting screw (8, Sheet 2).
- e. Remove thermostat (7).

### **REPAIR**

Repair at this level of maintenance is by replacement of worn or defective parts.

### **REPLACEMENT**

- a. Install thermostat (7).

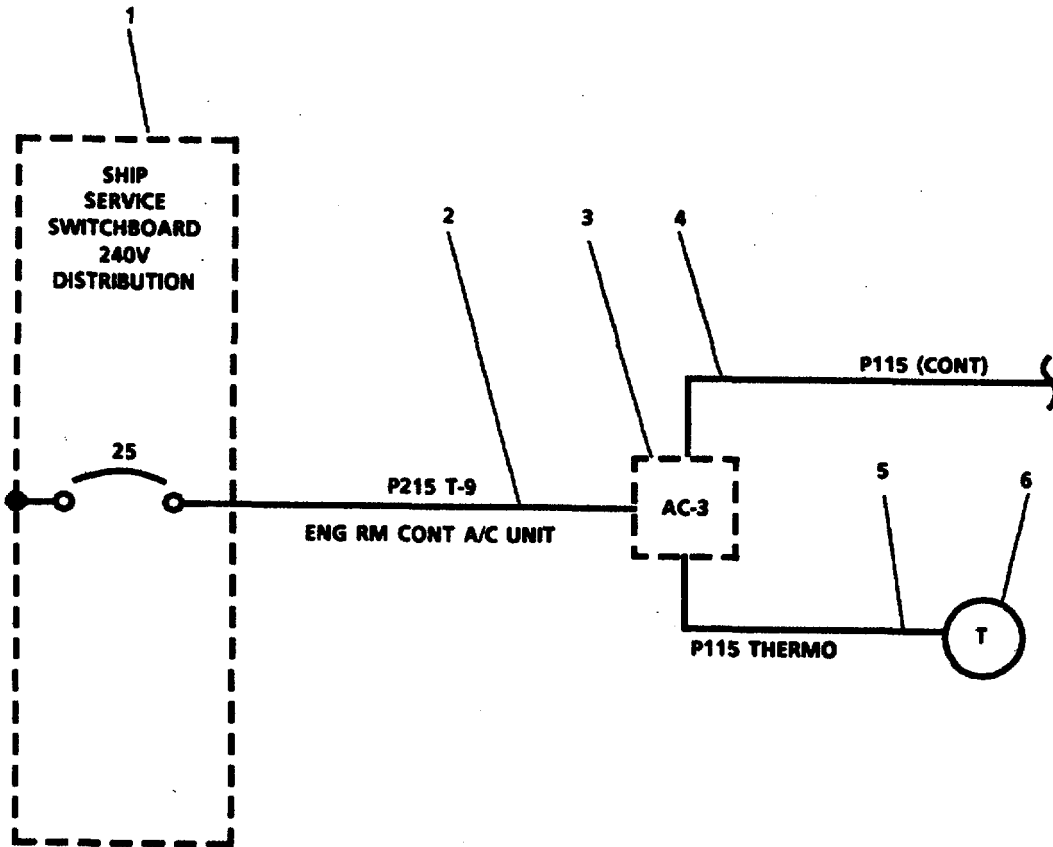

FIGURE 3-140. Engine Room Air Condition Power Distribution (Sheet 1 of 2).

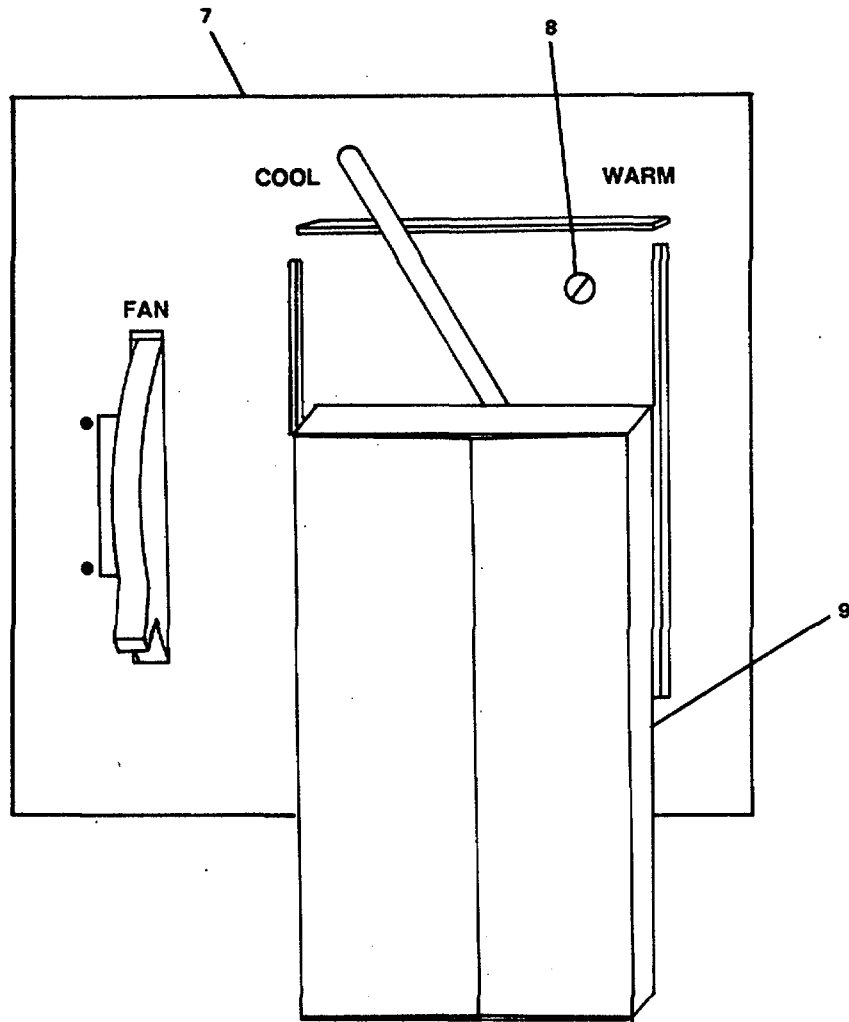

FIGURE 3-140. Engine Room Air Condition Power Distribution (Sheet 2 of 2).

- b. Install mounting screw (8) and cover (9).
- c. Remove tag and connect electrical power cable (P115) (thermo) (F-4) (5) to thermostat (Sheet 1).
- d. Remove tag and connect electrical power cable (P115) (CONT) (4).
- e. Install electrical power cable (P215) (F9) (2) to ship service switchboard (1) and AC-3(3). Connect cable.

---

**3-155. Replace/Repair Water Heater Power Distribution. (Figure 3-141)**

---

**This task covers:****a. Removal****b. Repair****c. Replacement****INITIAL SETUP:****Materials/Parts**

Disconnect switch P/N DH323FRK  
Warning tag, Item 1, Appendix C

**Equipment Condition**

Electrical power secured at ship  
service switchboard and tagged "  
"Out of Service - Do Not Operate."

---

**WARNING**

Death, serious injury, or equipment damage can result from contact with live electrical circuits. Before beginning work on this, or any other electrical equipment, turn power and control voltage circuit breakers OFF and tag "Out of Service - Do Not Operate."

**REMOVAL**

- a. Tag and disconnect electrical power cable (P216(1)) (T-14) (2, Sheet 1) from ship service switchboard (1).
- b. Tag and disconnect electrical power cable (P216(2)) (T-14) (3).
- c. Remove switching base (5, Sheet 2).
- d. Remove line shield (6).
- e. Remove operating handle (8).
- f. Remove operating mechanism (7).
- g. Remove attaching hardware and disconnect switch (4).

**REPAIR**

Repair at this level of maintenance is by replacement of disconnect switch (4).

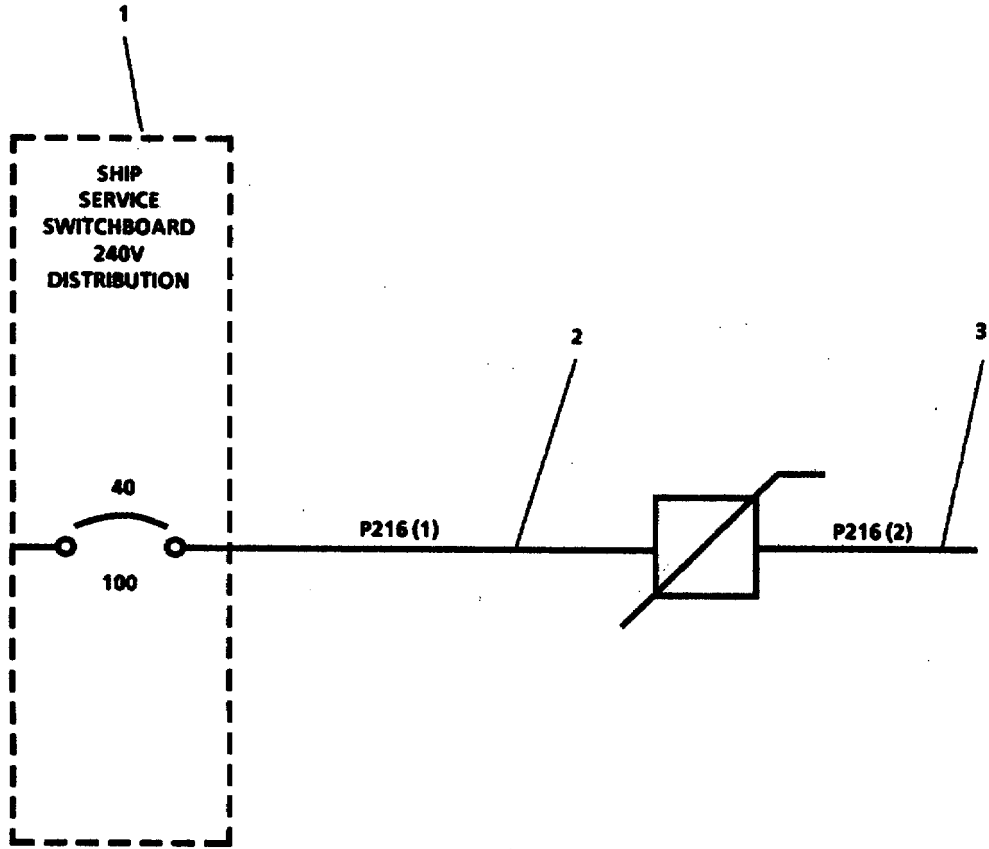

FIGURE 3-141. Water Heater Power Distribution (Sheet 1 of 2).



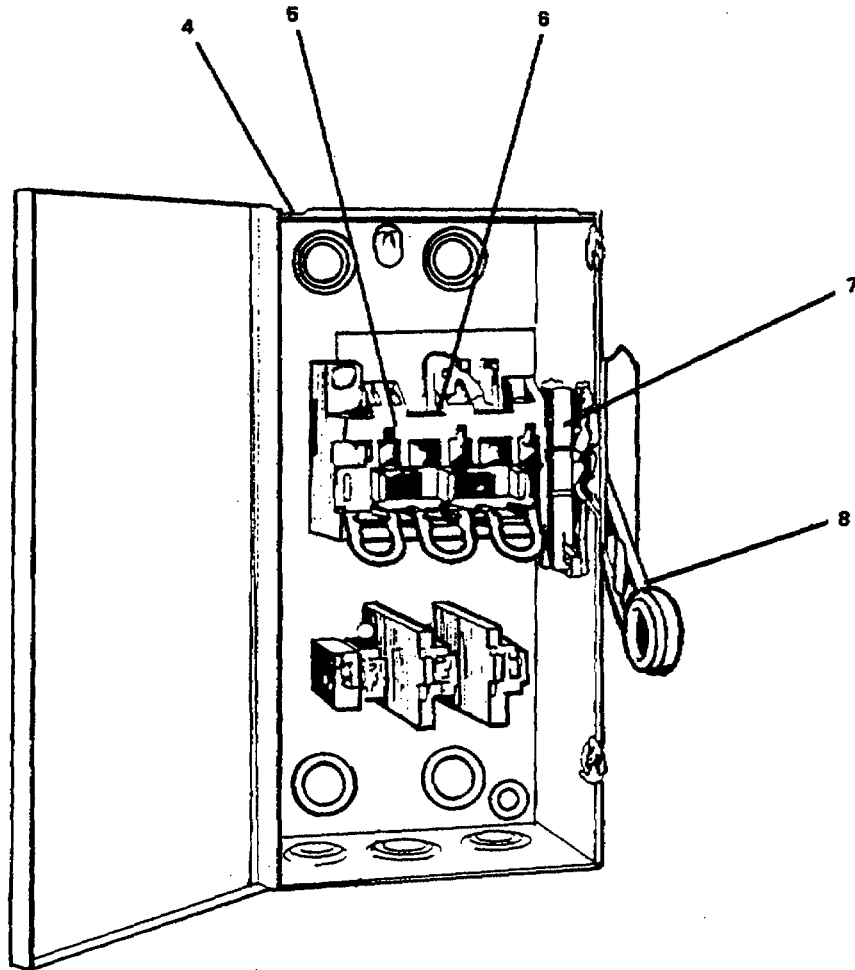

FIGURE 3-141. Water Heater Power Distribution (Sheet 2 of 2).

## REPLACEMENT

- a. Install disconnect switch (4).
- b. Install operating mechanism (7).
- c. Install operating handle (8).
- d. Install line shield (6).
- e. Install switching base (5).
- f. Remove tag and connect electrical power cable (P216(2)) (T-14) (3, Sheet 1).
- g. Remove tag and connect electrical power cable (P216(1)) (2) to ship service switchboard (1).
- h. Remove tag and turn ON electrical power.

---

**3-156. Repair Fresh Water Pump Number 1 Power Distribution.  
(Figure 3-142)**

---

**This task covers:**

- a. **Repair**
- 

**INITIAL SETUP:**

Tools

Tool kit, electrician's,  
5180-00-391-1087

Equipment Condition

Electrical power secured at ship  
service switchboard 240V distribution  
and tagged "Out of Service - Do Not Operate."  
(TM 55-1905-223-10).

Materials/Parts

Warning tag, Item 1, Appendix C

---

**WARNING**

Death, serious injury, or equipment damage can result from contact with live electrical circuits. Before beginning work on this, or any other electrical equipment, turn power and control voltage circuit breakers OFF and tag "Out of Service - Do Not Operate."

**REPAIR**

Repair at this level of maintenance is by replacement of electrical cables.

- a. Disconnect electrical power cables (2 through 4) from ship service switchboard (1) and associated equipment.
- b. Run new cable. Attach to ship service switchboard and associated equipment.

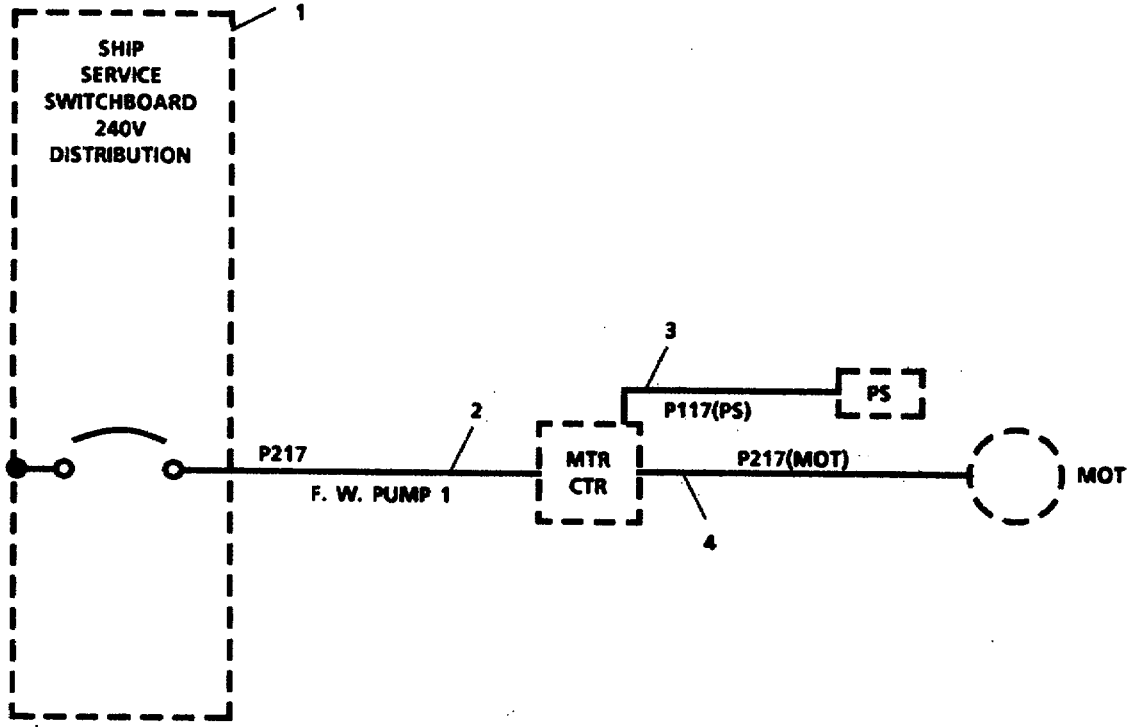

FIGURE 3-142. *Fresh Water Pump No. 1 Power Distribution.*

---

**3-157. Repair Fresh Water Pump Number 2 Power Distribution. (Figure 3-143)**

---

**This task covers:**

- a. Repair
- 

**INITIAL SETUP:**

Tools

Tool kit, electrician's,  
5180-00-391-1087

Materials/Parts

Warning tag, Item 1, Appendix C

---

Equipment Condition

Electrical power secured at ship  
service switchboard 240V distribution  
and tagged "Out of Service - Do Not  
Operate." TM 55-1905-223-10.

**WARNING**

Death, serious injury, or equipment damage can result from contact with live electrical circuits. Before beginning work on this, or any other electrical equipment, turn power and control voltage circuit breakers OFF and tag "Out of Service - Do Not Operate."

**REPAIR**

Repair at this level of maintenance is by replacement of electrical cables.

- a. Disconnect electrical power cables (1 through 3) from ship service switchboard and termination.
- b. Run new cable. Attach to ship service switchboard and termination.

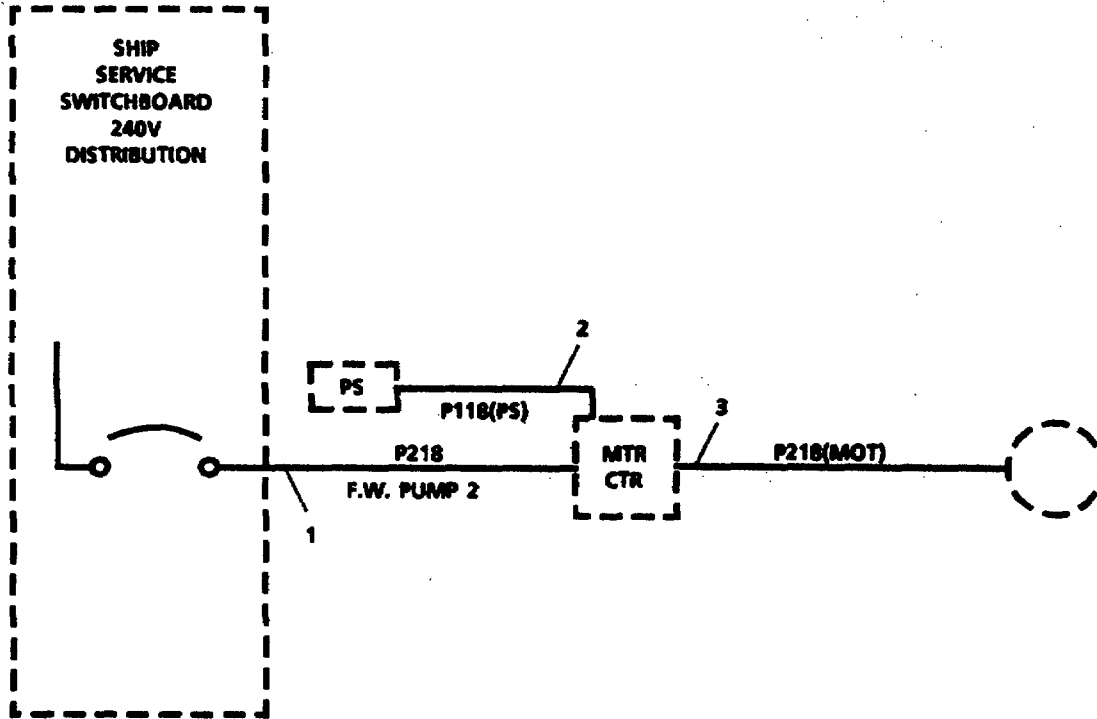

FIGURE 3-143. *Fresh Water Pump No. 2 Power Distribution.*

---

**3-158. Repair Stern Anchor Winch Power Distribution. (Figure 3-144)..**

---

**This task covers:**    a. **Repair.**

---

**INITIAL SETUP:**Tools

Tool kit, electrician's,  
5180-00-391-1087

Materials/Parts

Warning tag, Item 1, Appendix C

Equipment Condition

Electrical power secured at ship  
service switchboard 240V distribution  
and tagged "Out of Service - Do Not  
Operate." TM 55-1905-223-10.

---

**WARNING**

Death, serious injury, or equipment damage can result from contact with live electrical circuits. Before beginning work on this, or any other electrical equipment, turn power and control voltage circuit breakers OFF and tag "Out of Service - Do Not Operate."

**REPAIR**

Repair at this level of maintenance is by replacement of electrical cables.

- a. Disconnect electrical power cables (1 through 8) from ship service switchboard and termination.
- b. Run new cable. Attach to ship service switchboard and termination.

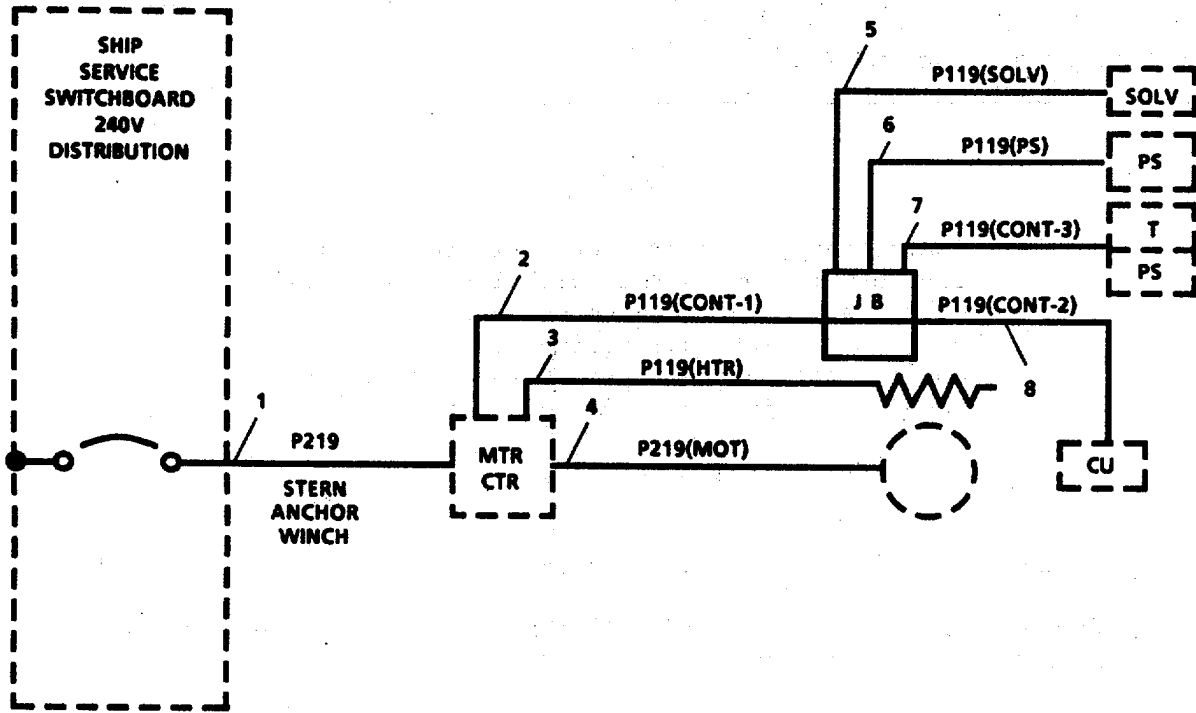

FIGURE 3-144. Stern Anchor Winch Power Distribution.



---

**3-159. Repair Boat Davit Power Distribution. (Figure 3-145).**

---

**This task covers:**    **a. Repair.**

---

**INITIAL SETUP:**Tools

Tool kit, electrician's,  
5180-00-391-1087

Materials/Parts

Warning tag, Item 1, Appendix C

Equipment Condition

Electrical power secured at ship  
service switchboard 240V distribution  
and tagged "Out of Service - Do Not  
Operate." TM 55-1905-223-10.

---

**WARNING**

Death, serious injury, or equipment damage can result from contact with live electrical circuits. Before beginning work on this, or any other electrical equipment, turn power and control voltage circuit breakers OFF and tag "Out of Service - Do Not Operate."

**REPAIR**

Repair at this level of maintenance is by replacement of electrical cables.

- a. Disconnect electrical power cables (1 through 4) from ship service switchboard and termination.
- b. Run new cable. Attach to ship service switchboard and termination.

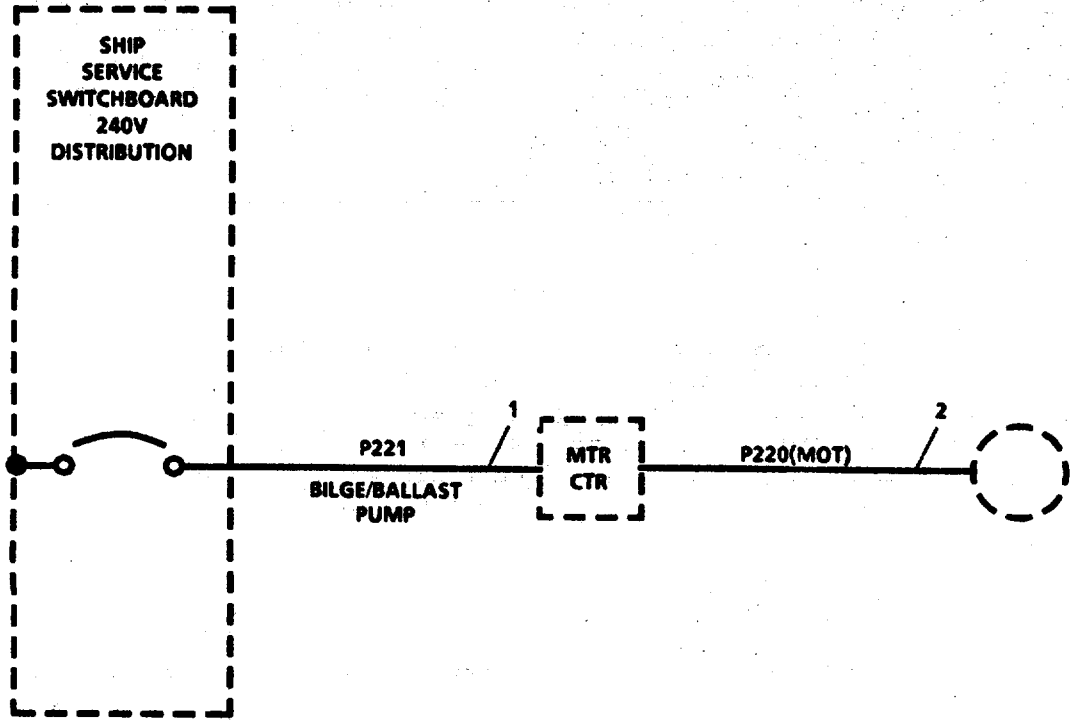

FIGURE 3-145. Boat Davit Power Distribution.

---

**3-160. Repair Bilge/Ballast Pump Power Distribution. (Figure 3-146)**

---

**This task covers:**    **a. Repair.**

---

**INITIAL SETUP:**Tools

Tool kit, electrician's,  
5180-00-391-1087

Materials/Parts

Warning tag, Item 1, Appendix C

Equipment Condition

Electrical power secured at ship  
service switchboard 240V distribution  
and tagged "Out of Service - Do Not  
Operate." TM 55-1905-223-10.

---

**WARNING**

Death, serious injury, or equipment damage can result from contact with live electrical circuits. Before beginning work on this, or any other electrical equipment, turn power and control voltage circuit breakers OFF and tag "Out of Service - Do Not Operate."

**REPAIR**

Repair at this level of maintenance is by replacement of electrical cables.

- a. Disconnect electrical power cables (1 and 2) from ship service switchboard and termination.
- b. Run new cable. Attach to ship service switchboard and termination.

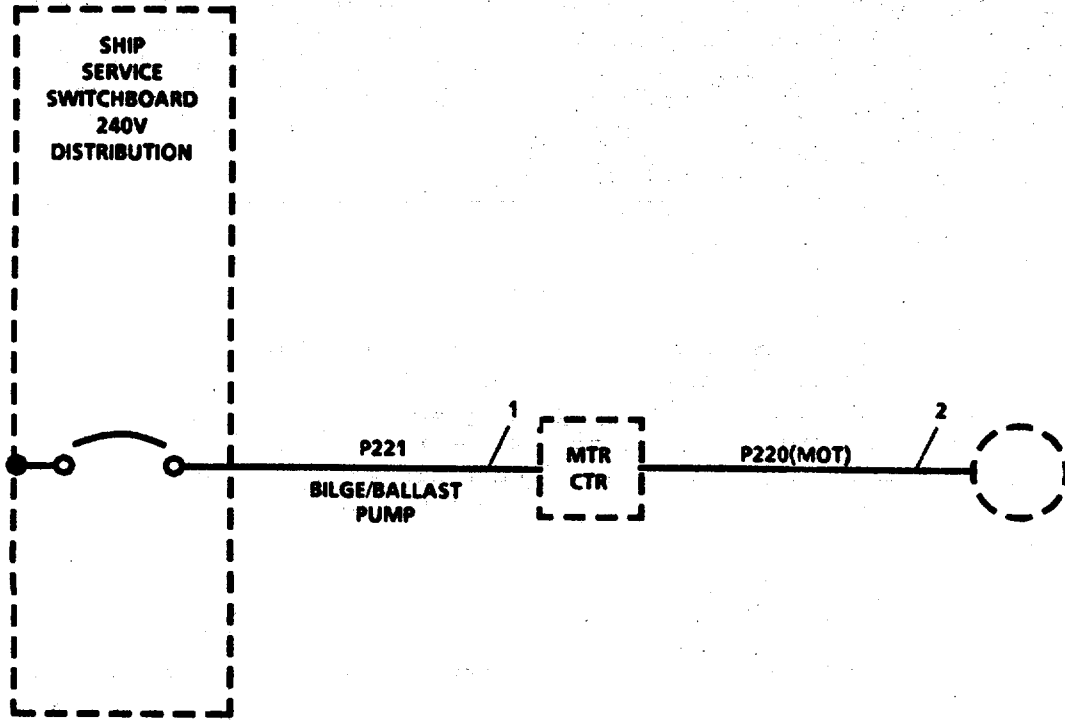

FIGURE 3-146. *Bilge/Ballast Pump Power Distribution.*

---

**3-161. Repair Boat Davit Power Distribution. (Figure 3-147).**

---

**This task covers:**    a. **Repair.**

---

**INITIAL SETUP:**Tools

Tool kit, electrician's,  
5180-00-391-1087

Materials/Parts

Warning tag, Item 1, Appendix C

Equipment Condition

Electrical power secured at ship  
service switchboard 240V distribution  
and tagged "Out of Service - Do Not  
Operate." TM 55-1905-223-10.

---

**WARNING**

Death, serious injury, or equipment damage can result from contact with live electrical circuits. Before beginning work on this, or any other electrical equipment, turn power and control voltage circuit breakers OFF and tag "Out of Service - Do Not Operate."

**REPAIR**

Repair at this level of maintenance is by replacement of electrical cables.

- a. Disconnect electrical power cables (1 and 2) from ship service switchboard and termination.
- b. Run new cable. Attach to ship service switchboard and termination.

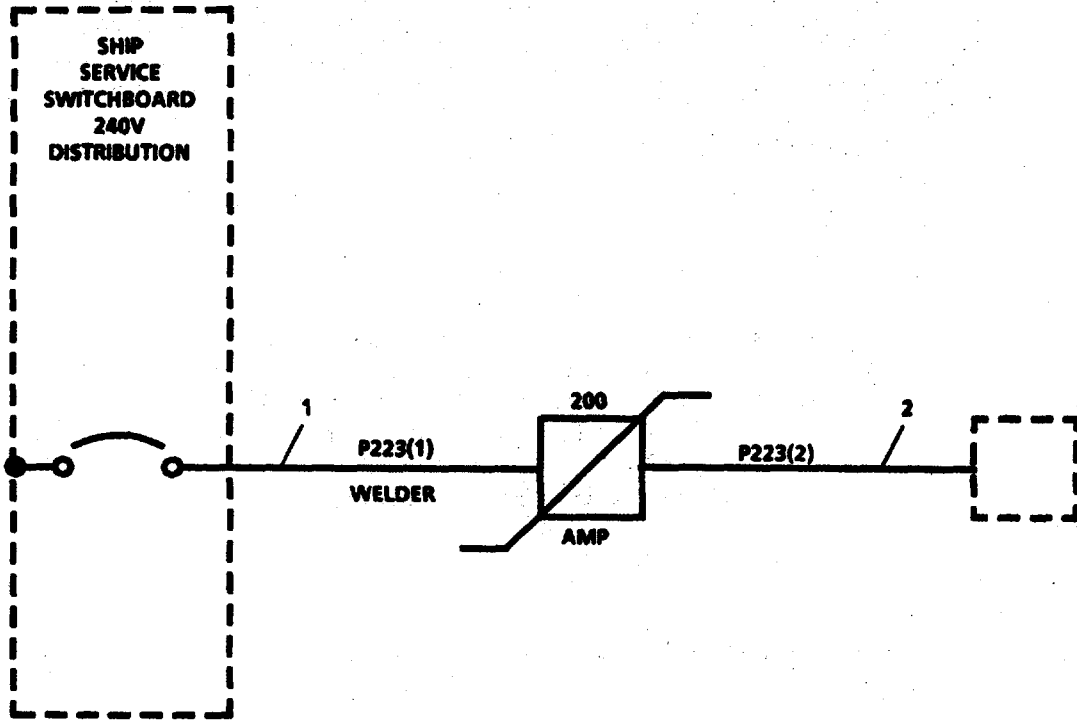

FIGURE 3-147. *Welder Power Distribution.*

---

**3-162. Replace/Repair Steering Gear, Port, Power Distribution. (Figure 3-148).**

---

**This task covers:**    **a. Repair.**

---

**INITIAL SETUP:**Tools

Tool kit, electrician's,  
5180-00-391-1087

Equipment Condition

Electrical power secured at ship  
service switchboard and tagged "Out  
of Service - Do Not Operate."

Materials/Parts

Warning tag, Item 1, Appendix C

---

**WARNING**

Death, serious injury, or equipment damage can result from contact with live electrical circuits. Before beginning work on this, or any other electrical equipment, turn power and control voltage circuit breakers OFF and tag "Out of Service - Do Not Operate."

**REMOVAL**

- a. Remove door assembly. Refer to 240V power distribution para. 2-125 .
- b. Tag and disconnect electrical power cable (P224) (T-9) (1).
- c. Tag and disconnect electrical power cable (P224MOT) (T-9) (2).
- d. Remove power distribution panel. Refer to 240V power distribution para. 2-125 .

**REPAIR**

Repair at this level of maintenance is by replacement of worn or defective parts.

**REPLACEMENT**

- a. Install power distribution panel. Refer to 240V power distribution para. 2-125 .

**Change 1 3-543**

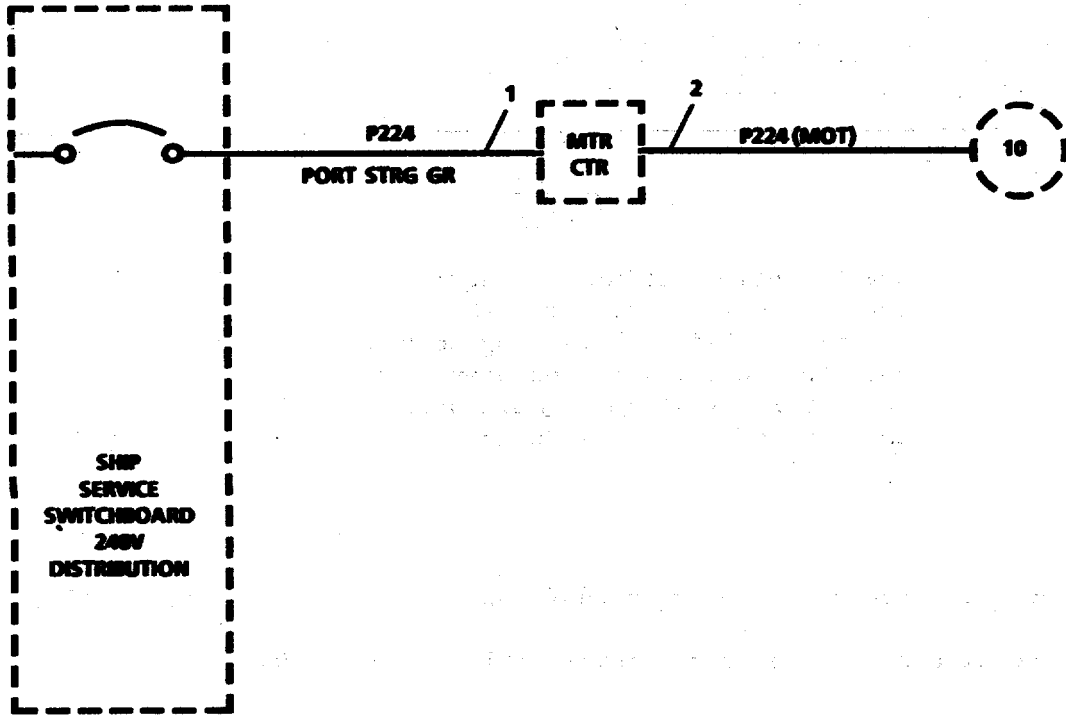

FIGURE 3-148. Steering Gear Port Power Distribution.



- b. Remove tag and connect electrical power cable (P224MOT) (T-9) (2).
- c. Remove tag and connect electrical power cable (P244) (T-9) (1).
- d. Install door assembly. Refer to 240V power distribution para. 2-157 .

---

**3-163. Repair Fire Pump Number 1 Power Distribution. (Figure 3-149).**

---

**This task covers:**    **a. Repair.**

---

**INITIAL SETUP:**Tools

Tool kit, electrician's,  
5180-00-391-1087

Materials/Parts

Warning tag, Item 1, Appendix C

Equipment Condition

Electrical power secured at ship  
service switchboard 240V distribution  
and tagged "Out of Service - Do Not  
Operate." TM 55-1905-223-10.

---

**WARNING**

Death, serious injury, or equipment damage can result from contact with live electrical circuits. Before beginning work on this, or any other electrical equipment, turn power and control voltage circuit breakers OFF and tag "Out of Service - Do Not Operate."

**REPAIR**

Repair at this level of maintenance is by replacement of electrical cables.

- a. Disconnect electrical power cables (1 through 3) from ship service switchboard and termination.
- b. Run new cable. Attach to ship service switchboard and termination.

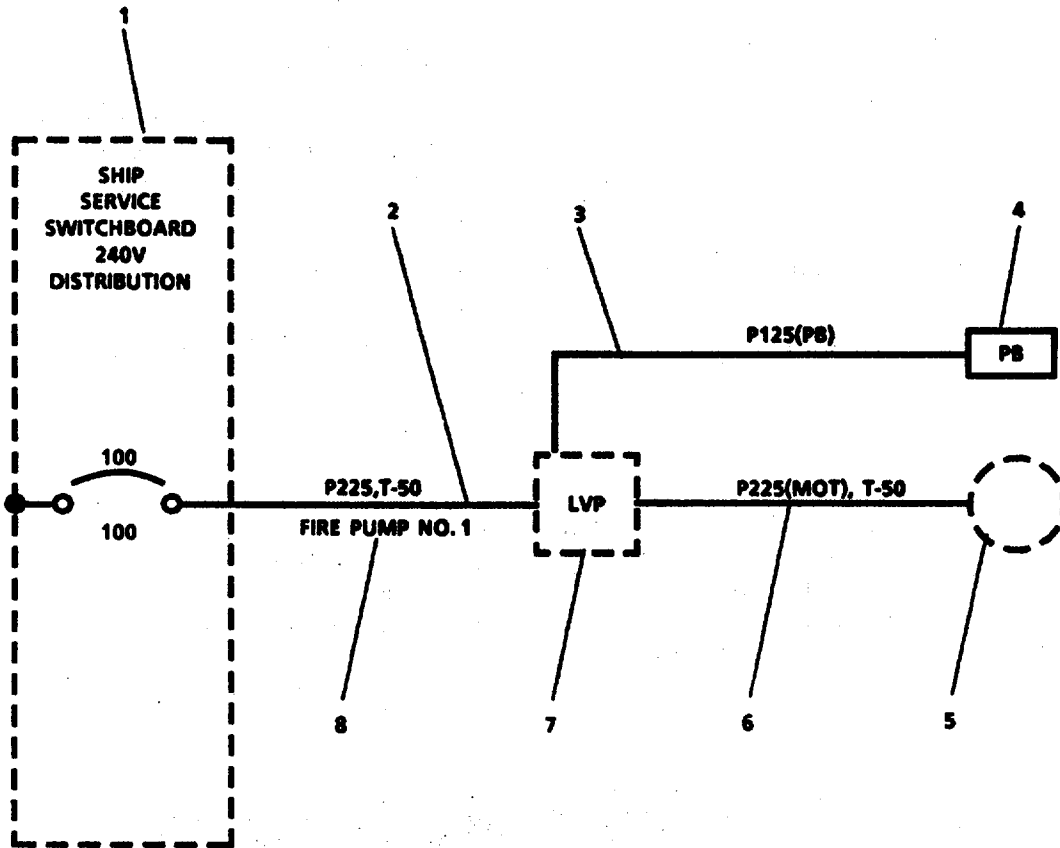

FIGURE 3-149. *Fire Pump No. 1 Power Distribution.*

---

**3-164. Replace/Repair Winch, Bow Ramp, Power Distribution. (Figure 3-150).**

---

**This task covers:**    a. **Repair.**

---

**INITIAL SETUP:**Tools

Tool kit, electrician's,  
5180-00-391-1087

Equipment Condition

Electrical power secured at ship  
service switchboard and tagged "Out  
of Service - Do No Operate."

Materials/Parts

Warning tag, Item 1, Appendix C

---

**WARNING**

Death, serious injury, or equipment damage can result from contact with live electrical circuits. Before beginning work on this, or any other electrical equipment, turn power and control voltage circuit breakers OFF and tag "Out of Service - Do Not Operate."

**REMOVAL**

- a. Remove door assembly. Refer to 240V power distribution para. 2-125 .
- b. Tag and disconnect electrical power cable (P226) (T-100) (1).
- c. Tag and disconnect electrical power cable (C-BR3) (M-10) (3).
- d. Tag and disconnect electrical power cable (P226MOT) (T-100) (2).
- e. Remove power distribution panel. Refer to 240V power distribution para. 2-125 .

**REPAIR**

Repair at this level of maintenance is by replacement of worn or defective parts.

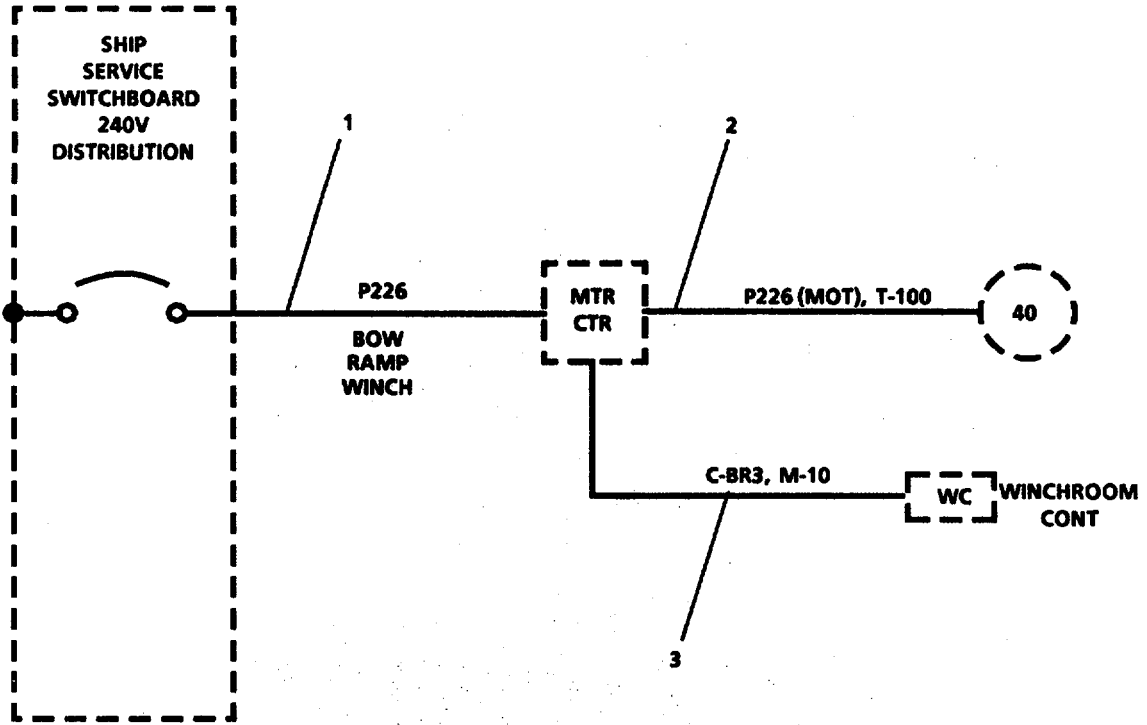

FIGURE 3-150. Winch Bow Ramp Power Distribution

## REPLACEMENT

- a. Install power distribution panel. Refer to 240V power distribution para. 2-157 .
- b. Remove tag and connect electrical power cable (P226MOT) (T-100) (2).
- c. Remove tag and connect electrical power cable (C-BR3) (M-10) (3).
- d. Remove tag and connect electrical power cable (P226) (T-100) (1).
- e. Install door assembly. Refer to 240V power distribution para. 2-157 .

---

**3-165. Repair 120V Power Distribution.**

---

**This task covers:**    a. **Repair.**

---

**REPAIR**

Repair of 120V Power Distribution is by repair of the components in the power distribution system. Refer to paragraphs 3-16.6 through 3-173.

---

**3-166. Repair Power Distribution.Panel P101 (Figure 3-151).**

---

**This task covers:**    a. **Repair.**

---

**INITIAL SETUP:**Tools

Tool kit, electrician's,  
5180-00-391-1087

Materials/Parts

Warning tags, Item 1, Appendix C

Equipment Condition

Main switchboard QTRS HEATER PANEL  
P101 125AT UVT circuit breaker Off  
and tagged "Out of Service - Do Not  
Operate." TM 55-1905-223-10.

---

**WARNING**

Death, serious injury, or equipment damage can result from contact with live electrical circuits. Before beginning work on this, or any other electrical equipment, turn power and control voltage circuit breakers OFF and tag "Out of Service - Do Not Operate."

**REPAIR****NOTE**

Repair of power distribution panel P101 is by replacement of associated electrical cables (1 through 10).

- a. Disconnect cable from power distribution panel and termination point.
- b. Run new cable. Attach to power distribution panel and termination point.



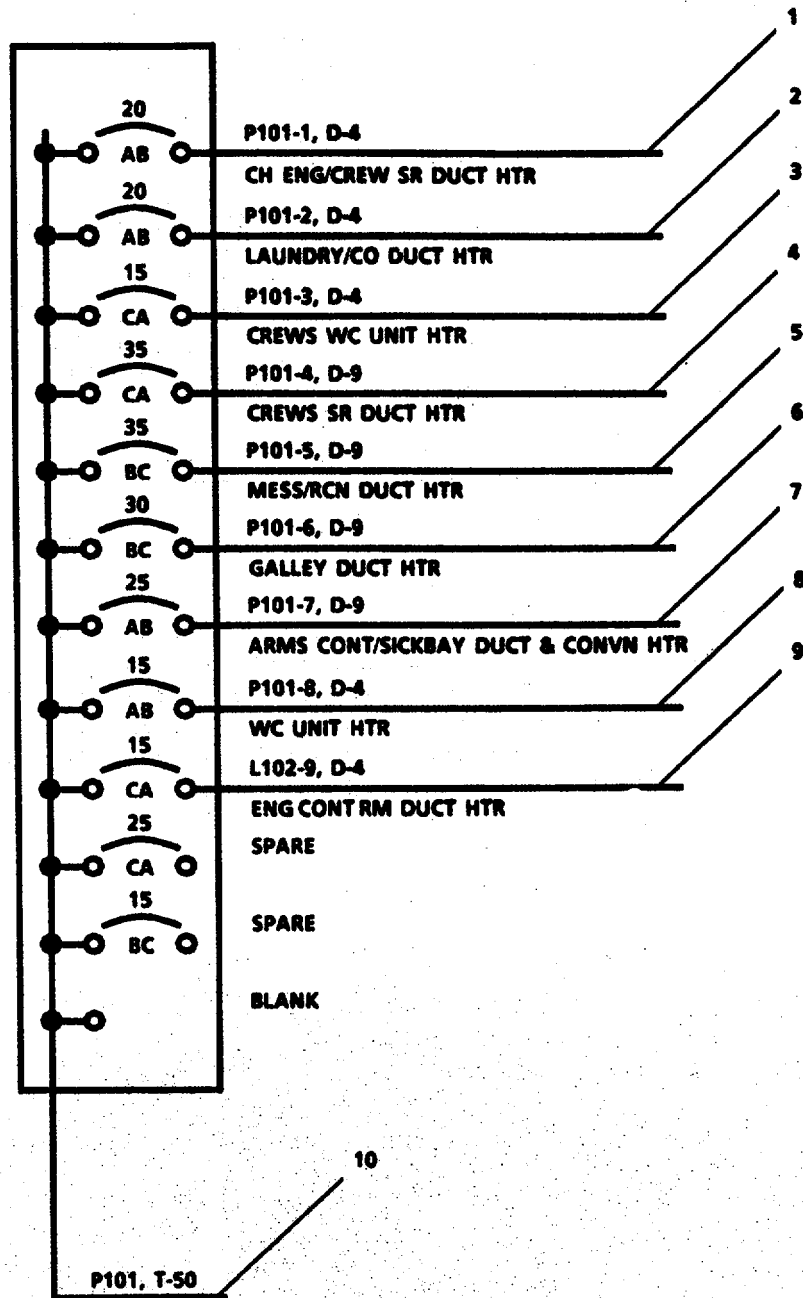

FIGURE 3-151. Power Distribution Panel P101.

---

**3-167. Repair Power Distribution.Panel L102. (Figure 3-152).**

---

**This task covers:**    **a. Repair.**

---

**INITIAL SETUP:**Tools

Tool kit, electrician's,  
5180-00-391-1087

Materials/Parts

Warning tag, Item 1, Appendix C

Equipment Condition

Main switchboard ENG ROOM LIGHTING  
PANEL L102 100AT circuit breaker OFF  
and tagged "Out of Service - Do Not  
Operate." TM 55-1905-223-10.

---

**WARNING**

Death, ,serious injury, equipment damage-can result from contact with live electrical circuits. Before beginning work on this, or any other electrical equipment, turn power and control voltage circuit breakers OFF and tag "Out of Service - Do Not Operate."

**REPAIR****NOTE**

Repair of power distribution panel L102-is by replacement of associated electrical cables (1 through 15).

- a. Disconnect cable from power distribution-panel and termination panel.
- b. Run new cable. Attach to power distribution pale and termination point.

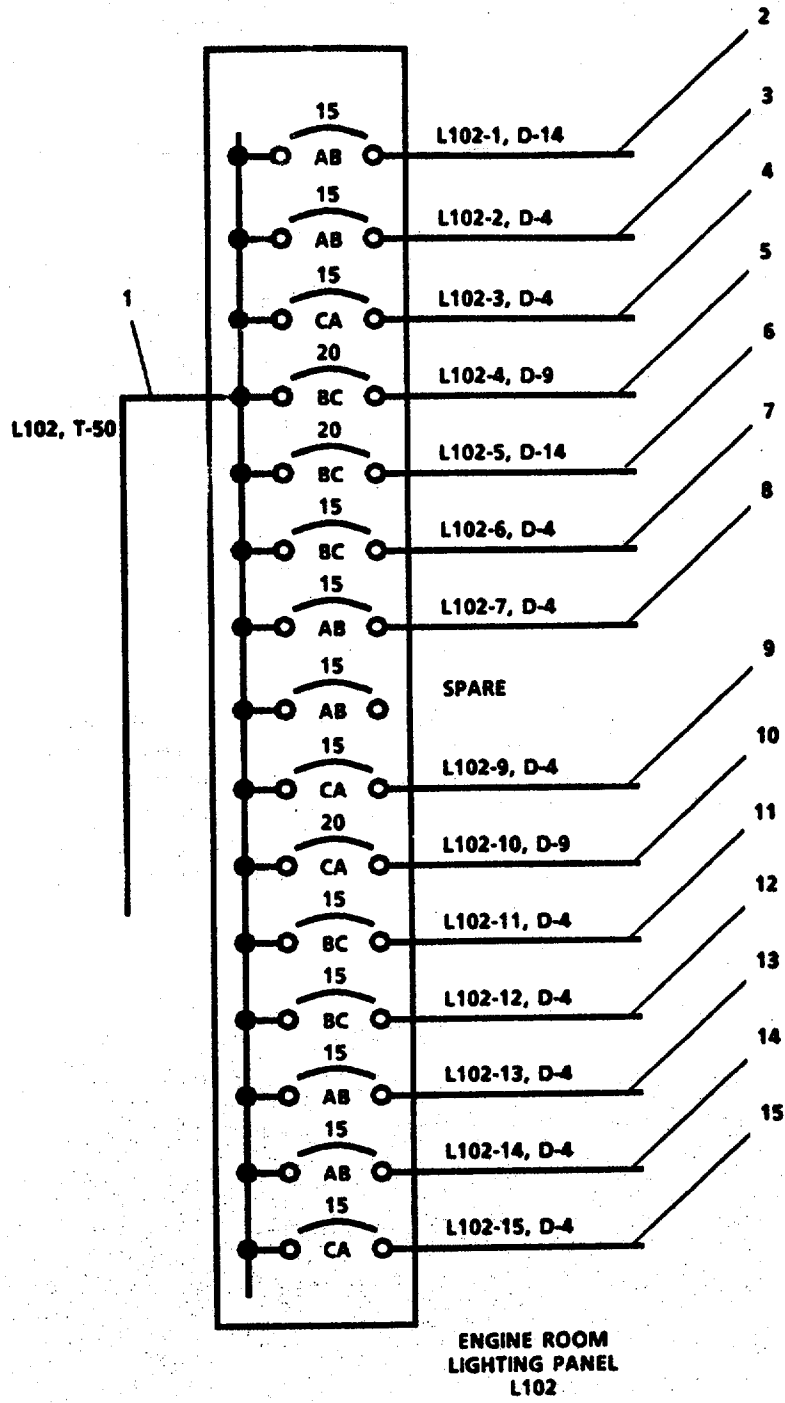

FIGURE 3-152. Power Distribution Panel L102

---

**3-168. Repair Power Distribution.Panel L104. (Figure 3-153).**

---

**This task covers:**    **a. Repair.**

---

**INITIAL SETUP:**Tools

Tool kit, electrician's,  
5180-00-391-1087

Materials/Parts

Warning tag, Item 1, Appendix C

Equipment Condition

Main switchboard MN DECK LIGHTING  
PANEL L104 100AT circuit breaker  
OFF and tagged "Out of Service -  
Do Not Operate." TM 55-1905-223-10.

---

**WARNING**

Death, serious injury, or equipment damage can result from contact with live electrical circuits. Before beginning work on this, or any other electrical equipment, turn power and control voltage circuit breakers OFF and tag "Out of Service - Do Not Operate."

**REPAIR****NOTE**

Repair of power distribution panel L104 is by replacement of associated electrical cables (1 through 19).

- a. Disconnect cable from power distribution panel and termination point.
- b. Run new cable. Attach to power distribution panel and termination point.

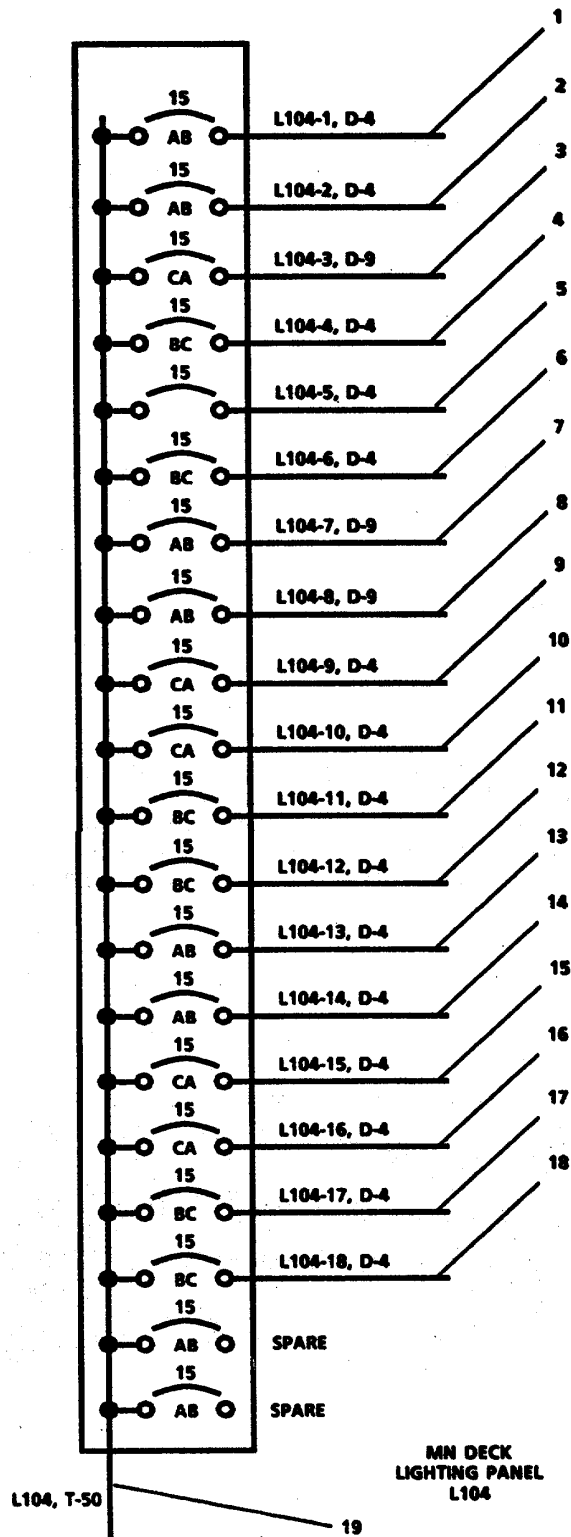

FIGURE 3-153. Power Distribution Panel L104.

---

**3-169. Repair Power Distribution.Panel L105. (Figure 3-154).**

---

**This task covers:**    a. **Repair.**

---

**INITIAL SETUP:**Tools

Tool kit, electrician's,  
5180-00-391-1087

Materials/Parts

Warning tag, Item 1, Appendix C

Equipment Condition

Main switchboard WHEEL HOUSE LIGHTING  
PANEL L105 45AT circuit breaker OFF  
and tagged "Out of Service - Do Not  
Operate." TM 55-1905-223-10.

---

**WARNING**

Death, serious injury, or equipment damage can result from contact with live electrical circuits. Before beginning work on this, or any other electrical equipment, turn power and control voltage circuit breakers OFF and tag "Out of Service - Do Not Operate."

**REPAIR****NOTE**

Repair of power distribution panel L105 (1) is by replacement of associated electrical cables (2 through 9).

- a. Disconnect cable from power distribution panel and termination point.
- b. Run new cable. Attach to power distribution panel and termination point.

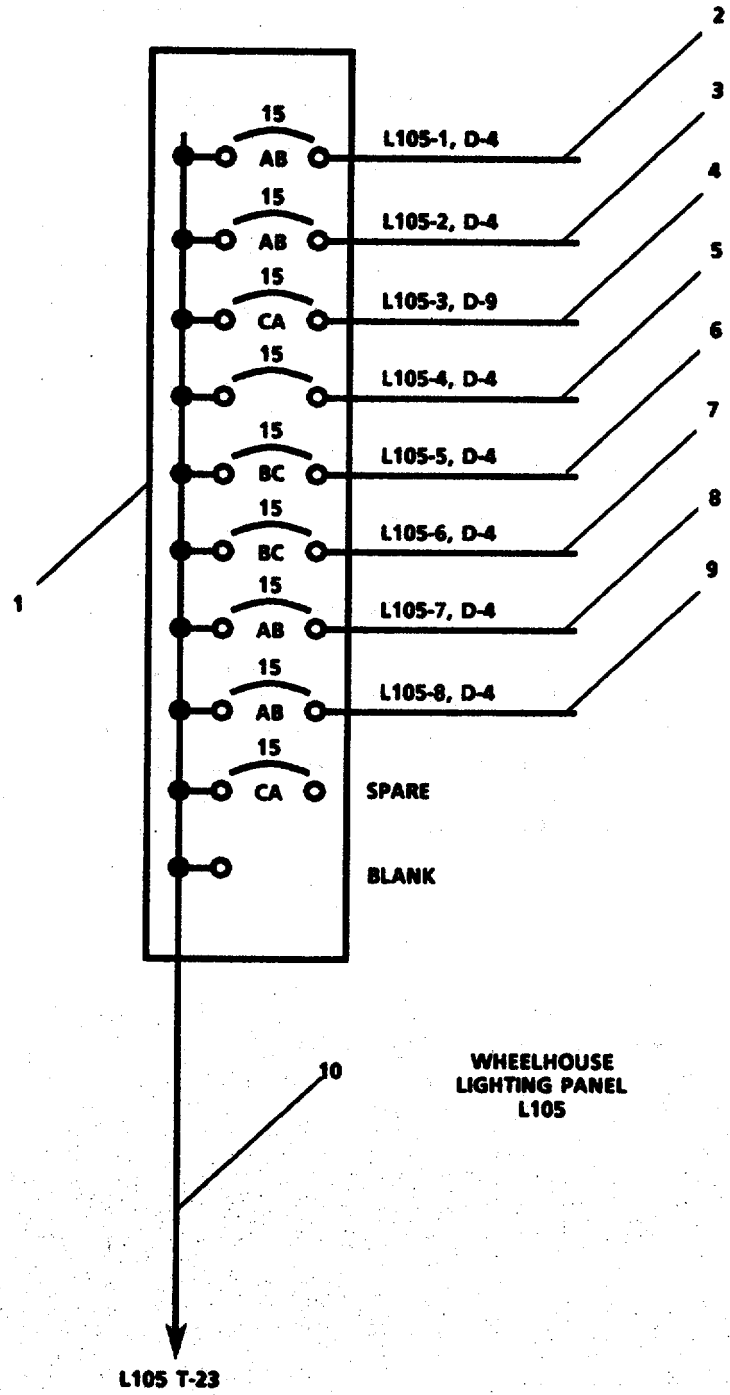

FIGURE 3-154. *Power Distribution Panel L105.*

---

**3-170. Repair Power Distribution Panel P106. (Figure 3-155)**

---

**This task covers:****a. Repair**

---

INITIAL SETUPToolsTool kit, electrician's,  
5180-00-391-1087Materials/Parts

Warning tag, Item 1, Appendix C

Equipment ConditionMain switchboard GALLEY 120V PANEL  
P106 80AT circuit breaker OFF and  
tagged "Out of Service - Do Not  
Operate." TM 55-1905-223-10.

---

WARNING

---

Death; serious injury, or equipment damage can result from contact with live electrical circuits. Before beginning work on this, or any other electrical equipment, turn power and control voltage circuit breakers OFF and tag "Out of Service - Do Not Operate.'

---

REPAIR

---

## NOTE

Repair of power distribution panel P106 is by replacement of associated electrical cables (1 through 15).

- a. Disconnect cable from power distribution panel and termination point.
- b. Run new cable. Attach to power distribution panel and termination point.



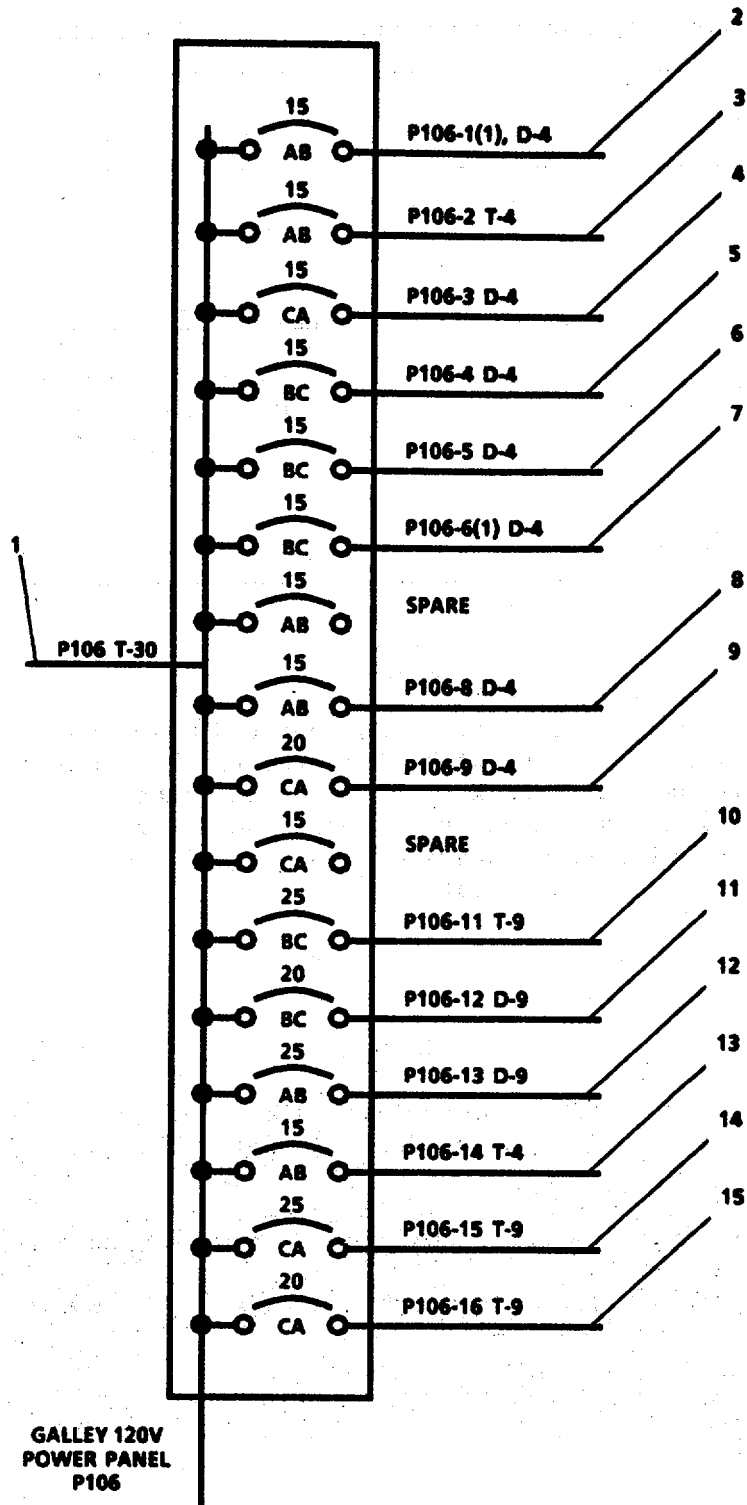

FIGURE 3-155. Power Distribution Panel P106.

---

**3-171. Repair 240V Emergency Power Distribution. (Figure 3-156)**

---

**This task covers:**

**a. Repair**

---

INITIAL SETUP

Tools

Tool kit, electrician's,  
5180-00-391-1087

Equipment Condition

Emergency switchboard circuit breakers  
OFF and tagged "Out of Service - Do  
Not Operate." TM 55-1905-223-10.

Materials/Parts

Warning tag, Item 1, Appendix C

---

WARNING

Death, serious injury, or equipment damage can result from contact with live electrical circuits. Before beginning work on this, or any other electrical equipment, turn power and control voltage circuit breakers OFF and tag "Out of Service - Do Not Operate."

REPAIR

NOTE

Repair of 240V emergency power distribution is by replacement of associated electrical cables (1 through 8).

- a. Disconnect cable from emergency switchboard and termination point.
- b. Run new cable. Attach to switchboard and termination point.

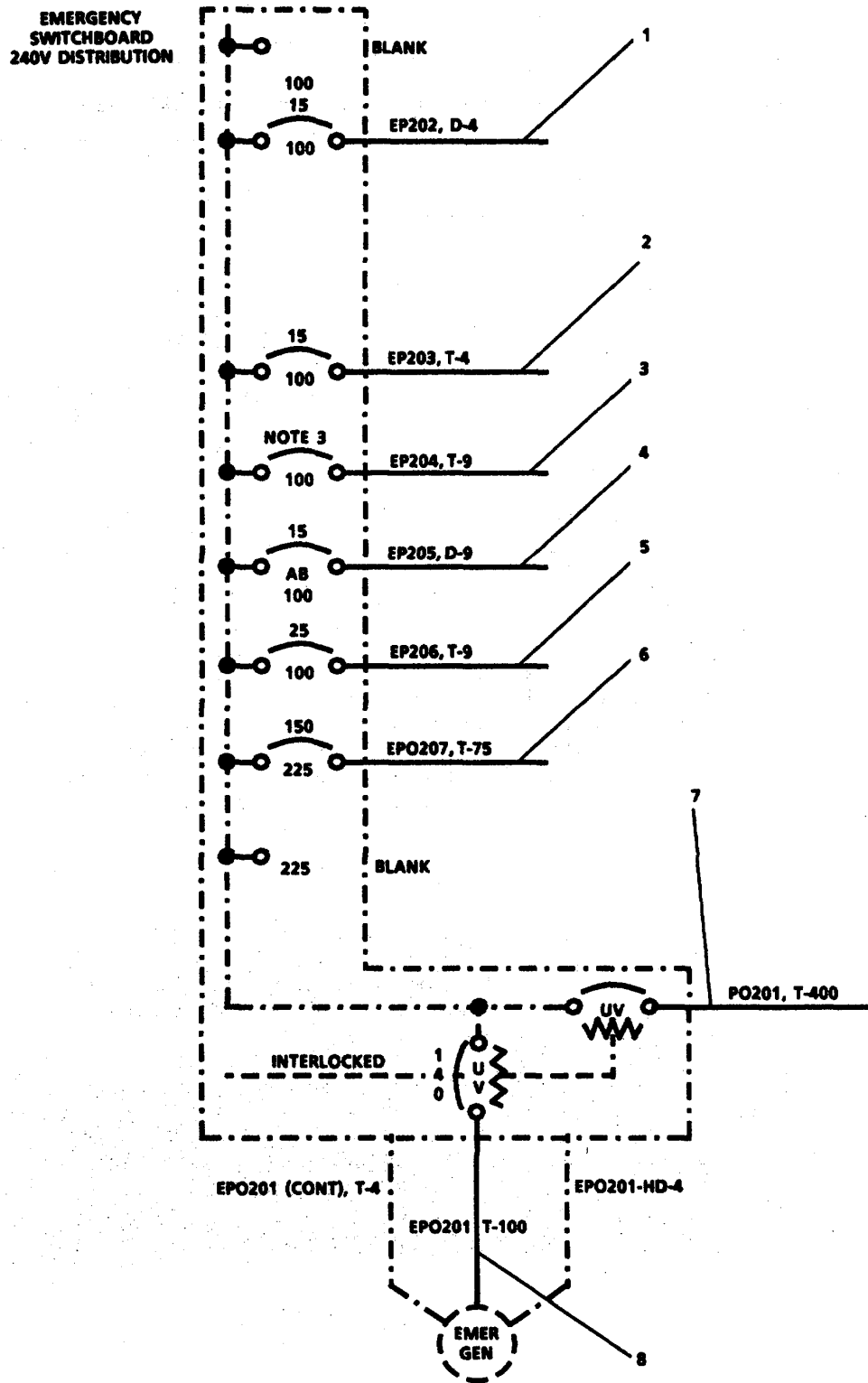

FIGURE 3-156. 240V Emergency Power Distribution.

**3-172. Repair 120V Emergency Power Distribution. (Figure 3-157)**

**This task covers:**

- a. Repair

INITIAL SETUP

Tools

Tool kit, electrician's,  
5180-00-391-1087

Materials/Parts

Warning tag, Item 1, Appendix C

Equipment Condition

Emergency switchboard circuit breakers  
OFF and tagged "Out of Service - Do  
Not Operate." TM 55-1905-223-10.

WARNING

Death, serious injury, or equipment damage can result from contact with live electrical circuits. Before beginning work on this, or any other electrical equipment, turn power and control voltage circuit breakers OFF and tag "Out of Service - Do Not Operate."

REPAIR

NOTE

Repair of 120V emergency power distribution is by replacement of associated electrical cables (1 through 10).

- a. Disconnect cable (1 through 10) from emergency switchboard and termination point.
- b. Run new cable. Attach to power distribution panel and switchboard.

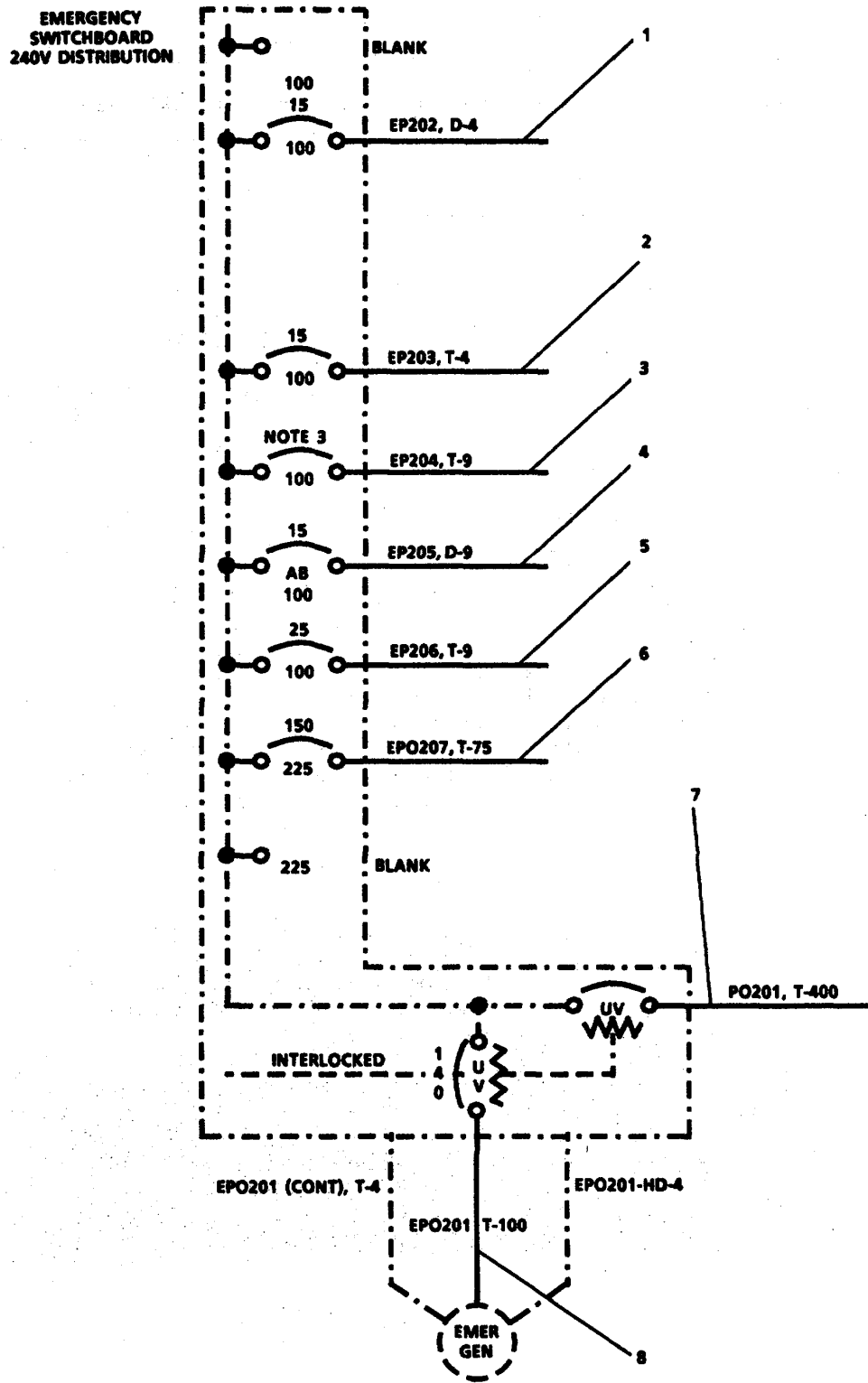

FIGURE 3-157. 120V Emergency Power Distribution.

---

**3-173. Repair Power Distribution Panel EL102. (Figure 3-158)**

---

**This task covers:****a. Repair**

---

INITIAL SETUPTools

Tool kit, electrician's,  
5180-00-391-1087

Materials/Parts

Warning tag, Item 1, Appendix, C

Equipment Condition

Emergency switchboard WHLHSE EMG LTG  
PNL EL 102 80AT circuit breaker OFF  
and tagged "Out of Service - Do Not  
Operate." TM 55-1905-223-10.

---

WARNING

Death, serious injury, or equipment damage can result from contact with live electrical circuits. Before beginning work on this, or any other electrical equipment, turn power and control voltage circuit breakers OFF and tag "Out of Service - Do Not Operate."

---

REPAIR

## NOTE

Repair of power distribution panel EL102 is by replacement of associated electrical cables (1 through 17).

- a. Disconnect cable (1 through 17) from power distribution panel and termination point.
- b. Run new cable. Attach to power distribution panel and termination point.

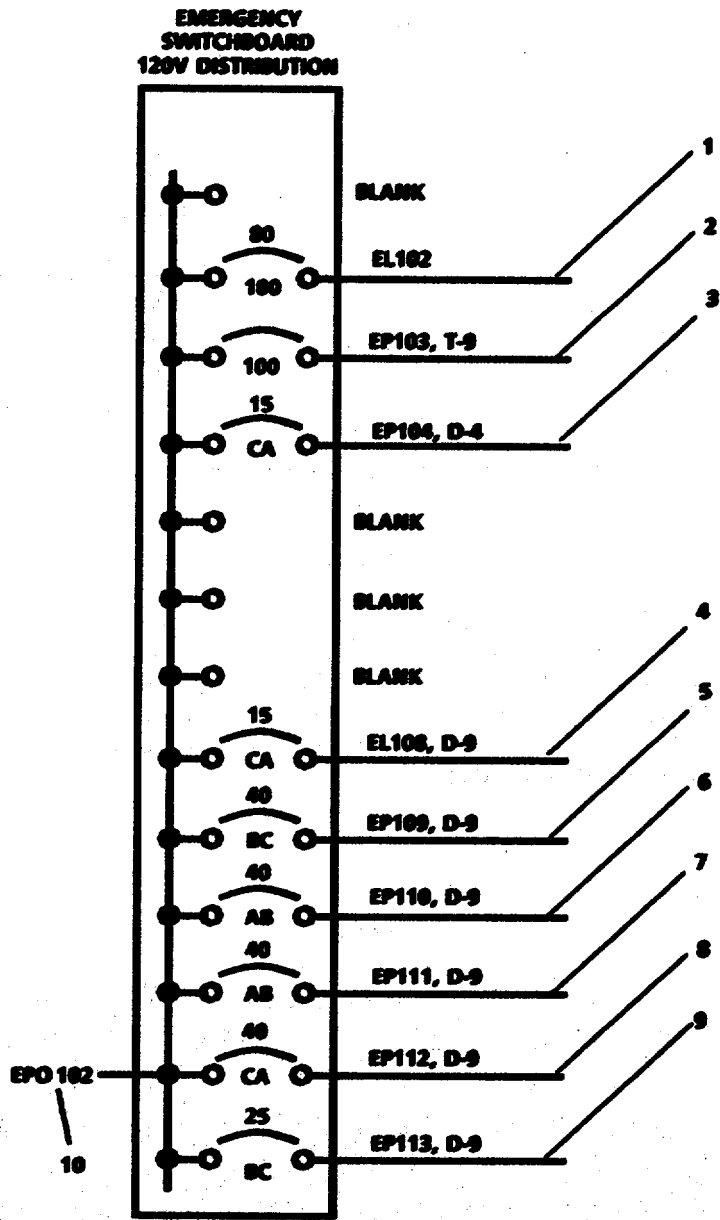

FIGURE 3-158. Power Distribution Panel EL102.

---

**3-174. Repair Power Distribution Panel EP103. (Figure 3-159)**

---

**This task covers:****a. Repair**

---

INITIAL SETUPTools

Tool kit, electrician's,  
5180-00-391-1087

Equipment Condition

Emergency switchboard WHL/HSE/ELEX  
PNL EP103 35AT circuit breaker OFF  
and tagged "Out of Service - Do Not  
Service." TM 55-1905-223-10.

Materials/Parts

Warning tag, Item 1, Appendix C

---

WARNING

Death, serious injury, or equipment damage can result from contact with live electrical circuits. Before beginning work on this, or any other electrical equipment, turn power and control voltage circuit breakers OFF and tag "Out of Service - Do Not Operate."

REPAIRNOTE

Repair of power distribution panel EP103 is by replacement of associated electrical cables (1 through 25).

- a. Disconnect cable (1 through 25) from power distribution panel and termination point.
- b. Run new cable. Attach to power distribution panel and termination point.



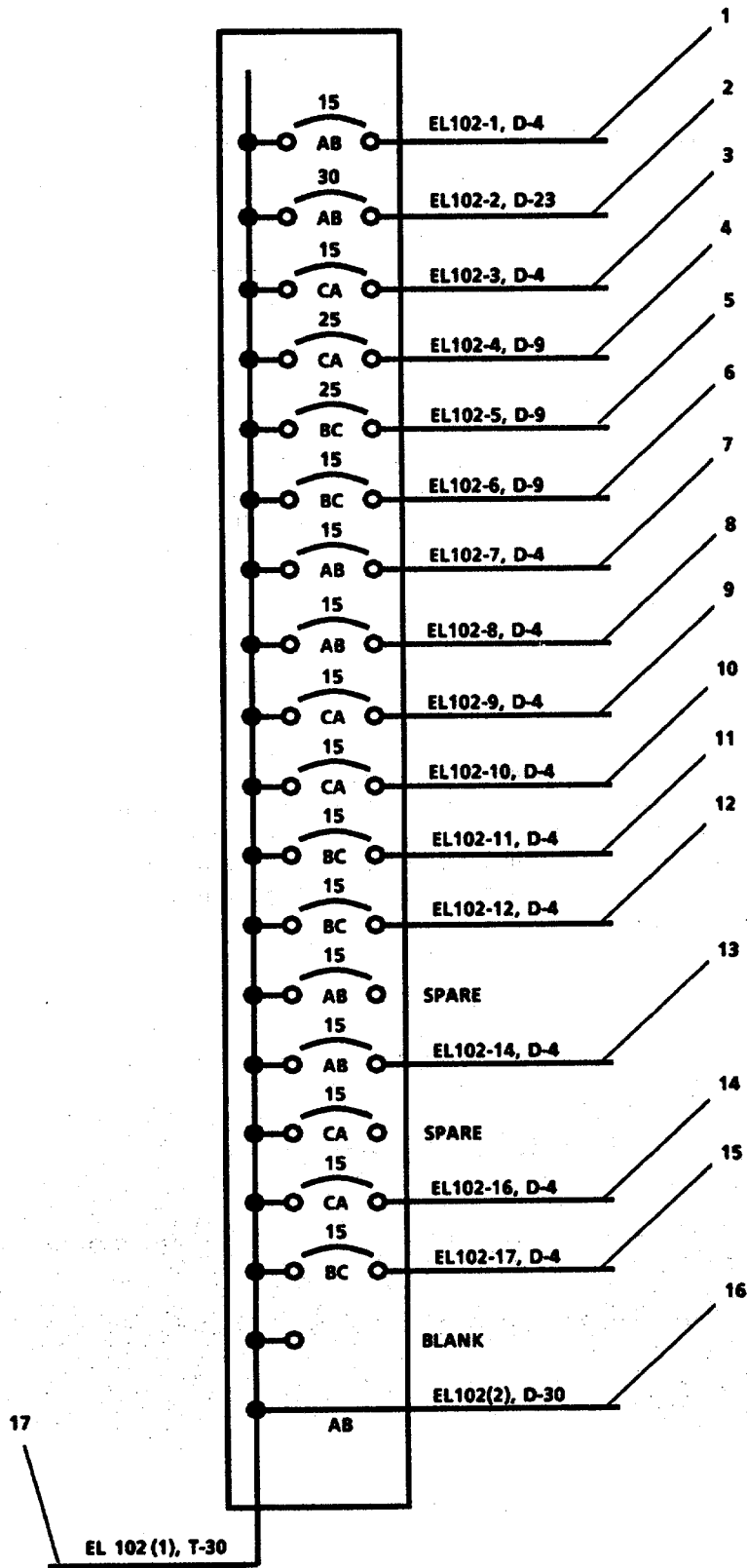

FIGURE 3-159. Power Distribution Panel (EP103) (Sheet 1 of 2).

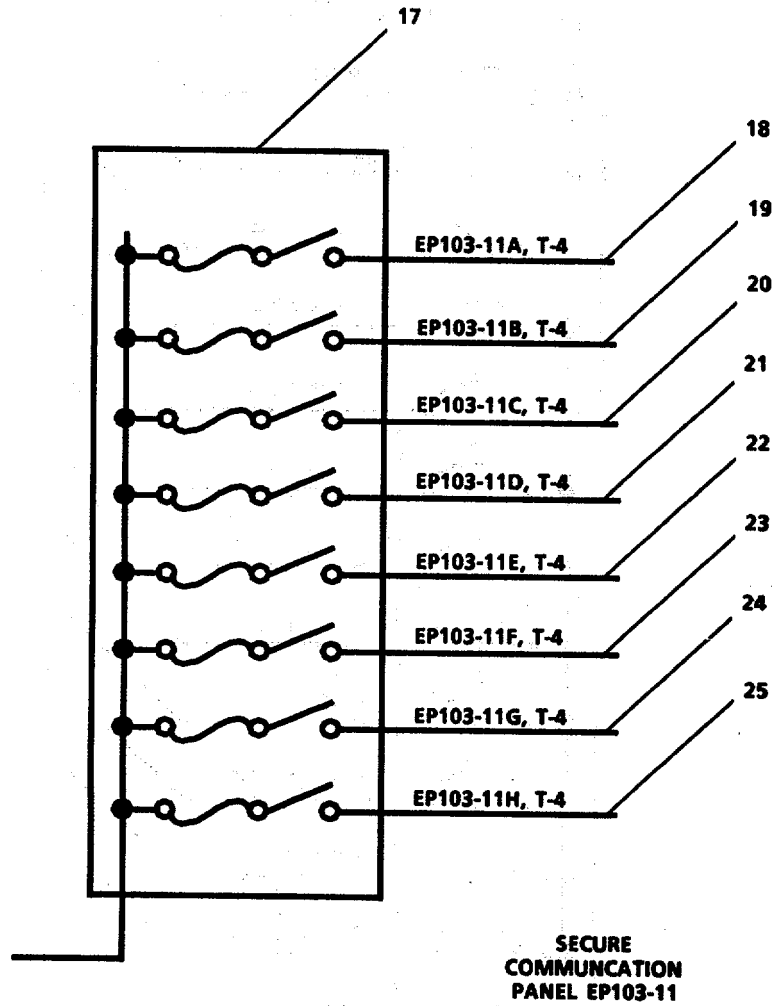

FIGURE 3-159. *Power Distribution Panel (EP103) (Sheet 2 of 2).*

**3-175. Repair Emergency Power Lighting. (Figure 3-160)**

**This task covers:**

**a. Repair**

INITIAL SETUP

Tools

Tool kit, electrician's,  
5180-00-391-1087

Materials/Parts

Warning tag, Item 1, Appendix C

Equipment Condition

Emergency switchboard circuit breakers  
OFF and tagged "Out of Service - Do  
Not Operate." TM 55-1905-223-10.

WARNING

Death, serious injury, or equipment damage can result from contact with live electrical circuits. Before beginning work on this, or any other electrical equipment, turn power and control voltage circuit breakers OFF and tag "Out of Service - Do Not Operate."

REPAIR

NOTE

Repair of emergency power lighting is by replacement of associated electrical cables (1 through 7).

- a. Disconnect cable (1 through 7) from emergency switchboard and termination point.
- b. Run new cable. Attach to switchboard and termination point.

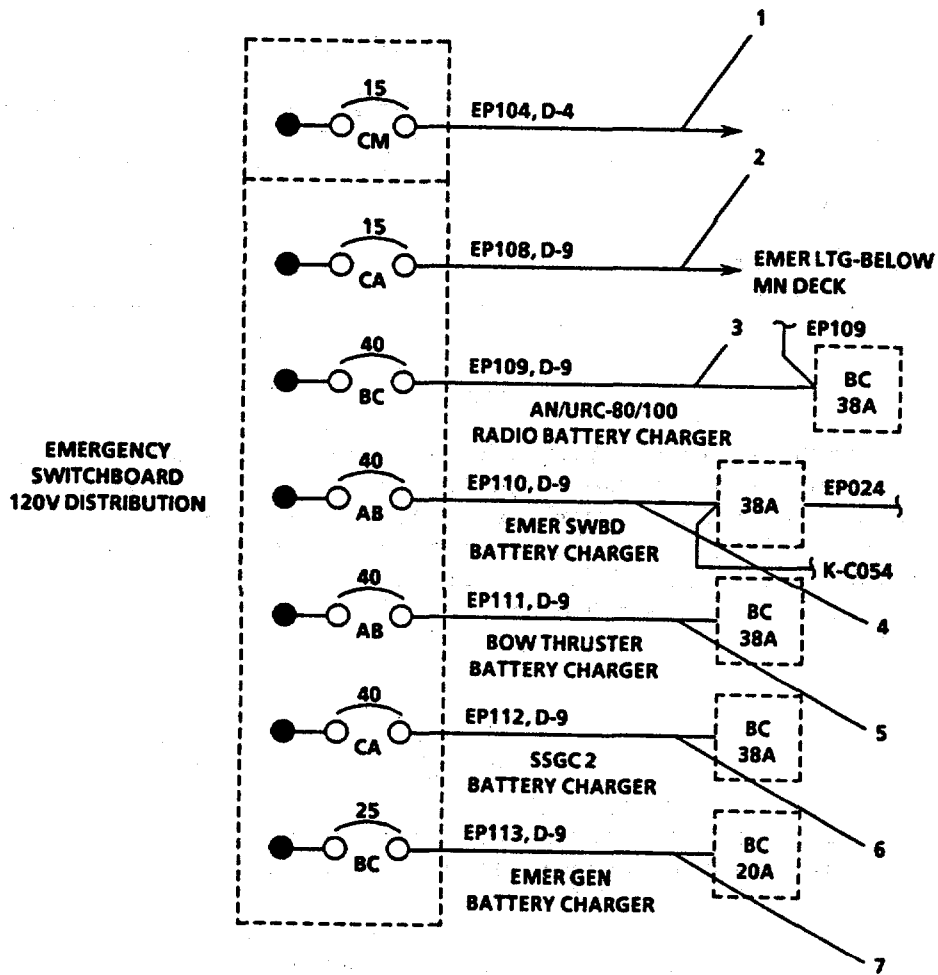

FIGURE 3-160. Emergency Power Lighting.

---

**3-176. Repair 24VDC Emergency Power Distribution.**

---

**This task covers:**

**a. Repair**

---

INITIAL SETUP

Tools

Tool kit, electrician's,  
5180-00-391-1087

Equipment Condition

Emergency switchboard circuit breakers  
OFF and tagged "Out of Service - Do  
Not Operate." TM 55-1905-223-10.

Materials/Parts

Warning tag, Item 1, Appendix C

---

WARNING

Death, serious injury, or equipment damage can result from contact with live electrical circuits. Before beginning work on this, or any other electrical equipment, turn power and control voltage circuit breakers OFF and tag 'Out of Service - Do Not Operate.'

REPAIR

Repair of 24VDC Emergency Power Distribution is by repair of power distribution panel EP024. Refer to paragraph 3-177 .

---

**3-177. Repair Power Distribution Panel EP024 (EP024-1 and EP024 Section B).  
(Figure 3-161)**

---

**This task covers:**

**a. Repair**

---

INITIAL SETUP

Tools

Tool kit, electrician's,  
5180-00-392-2895

Equipment Condition

Emergency switchboard circuit breakers  
OFF and tagged "Out of Service - Do  
Not Operate." TM 55-1905-223-10.

Materials/Parts

Warning tag, Item 1, Appendix C

---

WARNING

Death, serious injury, or equipment damage can- result from contact with live electrical circuits. Before beginning work on this, or any other electrical equipment, turn power and control voltage circuit breakers OFF and tag "Out of Service - Do Not Operate."

REPAIR

NOTE

Repair of power distribution panel EP024 is by replacement of associated electrical cables (1 through 20).

- a. Disconnect cable (1 through 20) from power distribution panel and termination point.
- b. Run new cable. Attach to power distribution panel and termination point.

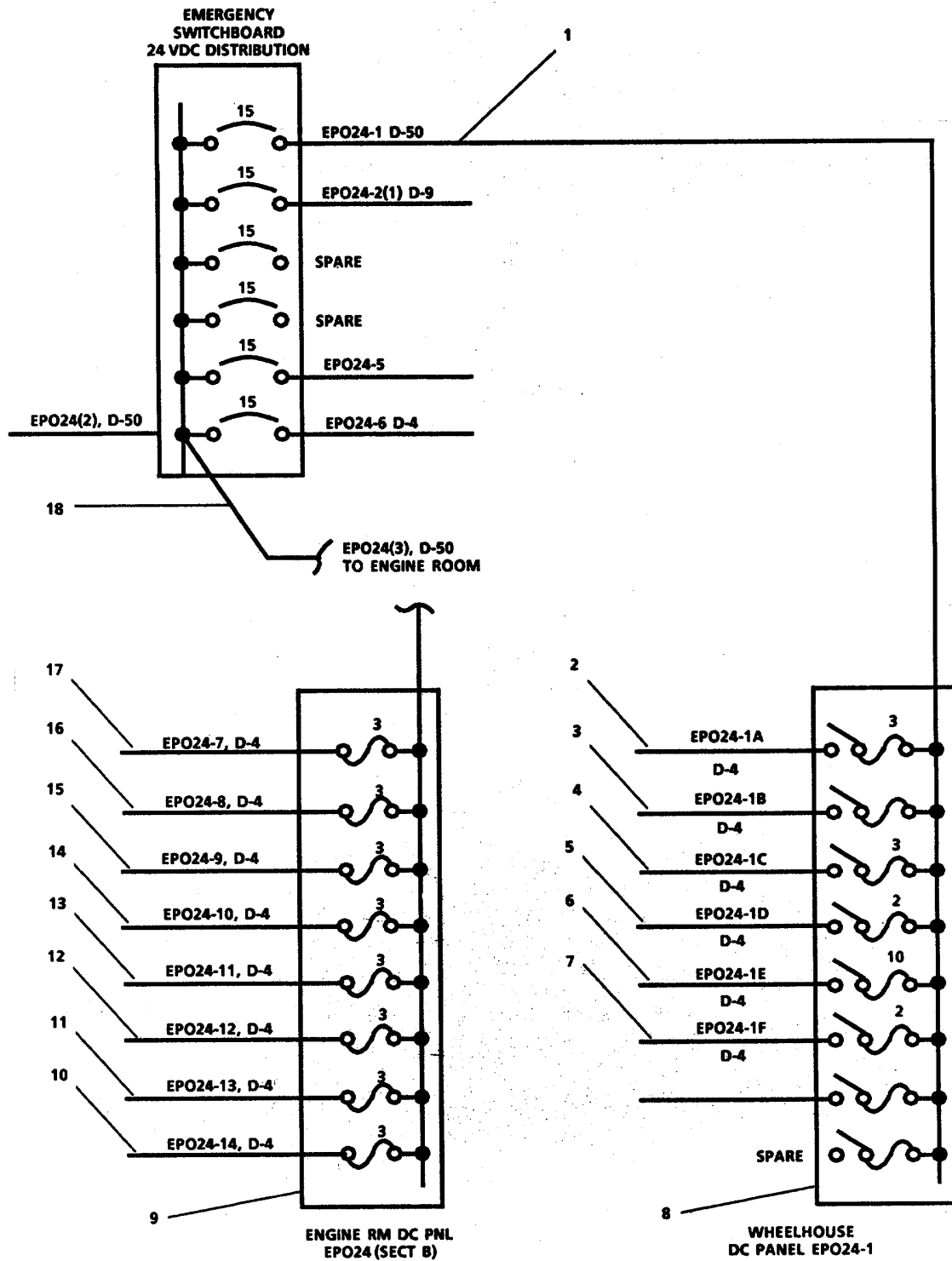

FIGURE 3-161. Emergency Power 24 Volt Distribution.

**3-178. Repair Battery Storage Group.**

---

Repair of battery storage group is by repair of the components in the group. Refer to paragraphs 3-179 through 3-184 .



---

**3-179. Repair Emergency Generator Switchboard Battery Assembly. (Figure 3-162)**

---

**This task covers:****a. Repair**

---

INITIAL SETUPTools

Tool kit, electrician's,  
5180-00-391-1087

Materials/Parts

Warning tag, Item 1, Appendix C

Equipment Condition

Emergency switchboard EMERG SWBD BATT  
CHGR EP1IO 40AT circuit breaker OFF  
and tagged "Out of Service - Do Not  
Operate." TM 55-1905-223-10.

---

WARNING

---

Death, serious injury, or equipment damage can result from contact with live electrical circuits. Before beginning work on this, or any other electrical equipment, turn power and control voltage circuit breakers OFF and tag "Out of Service - Do Not Operate."

---

REPAIRNOTE

Repair of emergency switchboard battery assembly is by replacement of associated electrical cables (1 through 3).

- a. Disconnect cable from emergency switchboard and termination point.
- b. Run new cable. Attach to power distribution panel and switchboard.

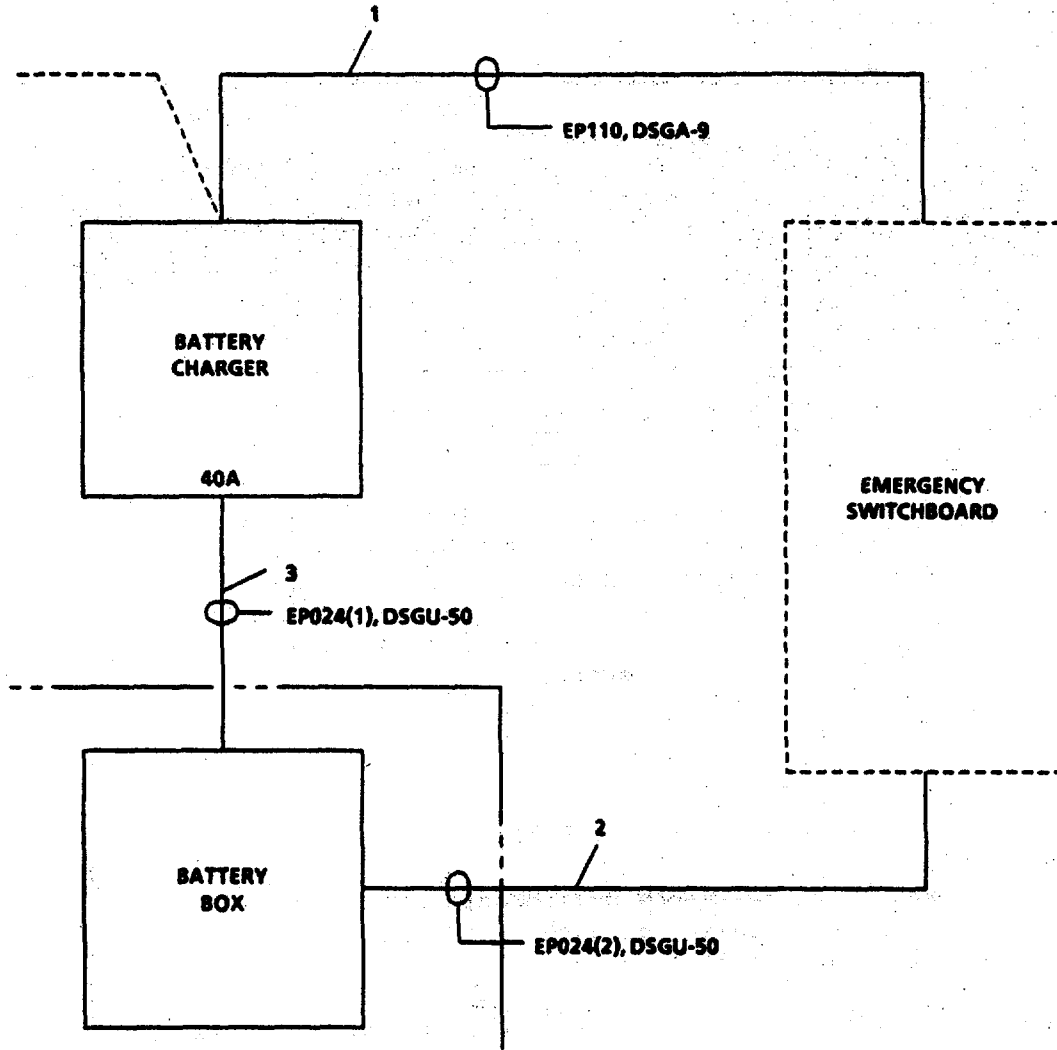

FIGURE 3-162. *Emergency Switchboard Battery Assembly.*

---

**3-180. Repair Emergency Switchboard Battery Charger. (Figure 3-163)**

---

**This task covers:****a. Repair**

---

INITIAL SETUPTools

Tool kit, electrician's,  
5180-00-391-1087

Equipment Condition

EMERG SWBD BATT CHGR EP110 40AT circuit  
breaker OFF and tagged "Out of  
Service - Do Not Operate."  
TM 55-1905-223-10

Materials/Parts

Transformer P/N IG2FI-02113A

---

WARNING

Death, serious injury, or equipment damage can result from contact with live electrical circuits. Before beginning work on this, or any other electrical equipment, turn power and control voltage circuit breakers OFF and tag "Out of Service - Do Not Operate."

REPAIR

## NOTE

Repair of battery charger at this level is by replacement of the transformer (3).

- a. Loosen door latch screw (2). Open door (1).
- b. Remove electrical connections and mounting screws from transformer (3).
- c. Remove transformer (3) (located behind fuse block).
- d. Install transformer (3). Secure with mounting screws.
- e. Attach electrical connections.
- f. Close door (1). Tighten door latch screws (3).
- g. Apply power. Remove tag.

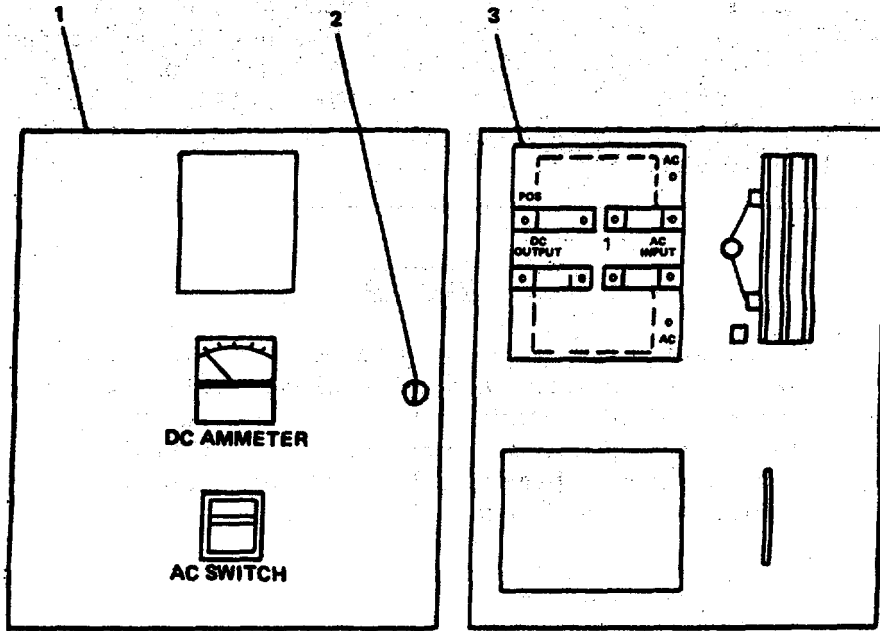

FIGURE 3-163. Battery Charger Repair.

**3-181. Repair Pilot House Battery Assembly. (Figure 3-164)**

**This task covers:**

- a. Repair

INITIAL SETUP

Tools

Tool kit, electrician's,  
5180-00-391-1087

Materials/Parts

Warning tag, Item 1, Appendix C  
Transformer P/N IG2FI-02113A

Equipment Condition

AN-VRC-80 BATT CHGR EP109 40AT circuit  
breaker OFF and tagged "Out of  
Service - Do Not Operate."  
TM 55-1905-223-10.

WARNING

Death, serious injury, or equipment damage can result from contact with live electrical circuits. Before beginning work on this, or any other electrical equipment, turn power and control voltage circuit breakers OFF and tag "Out of Service - Do Not Operate."

REPAIR

NOTE

Repair of pilot house battery assembly is by replacement of associated electrical cables (1 through 8) and by repair of battery charger. Refer to paragraph 3-180 for repair of battery charger.

- a. Disconnect cable from source and termination point.
- b. Run new cable. Attach to source and termination point.

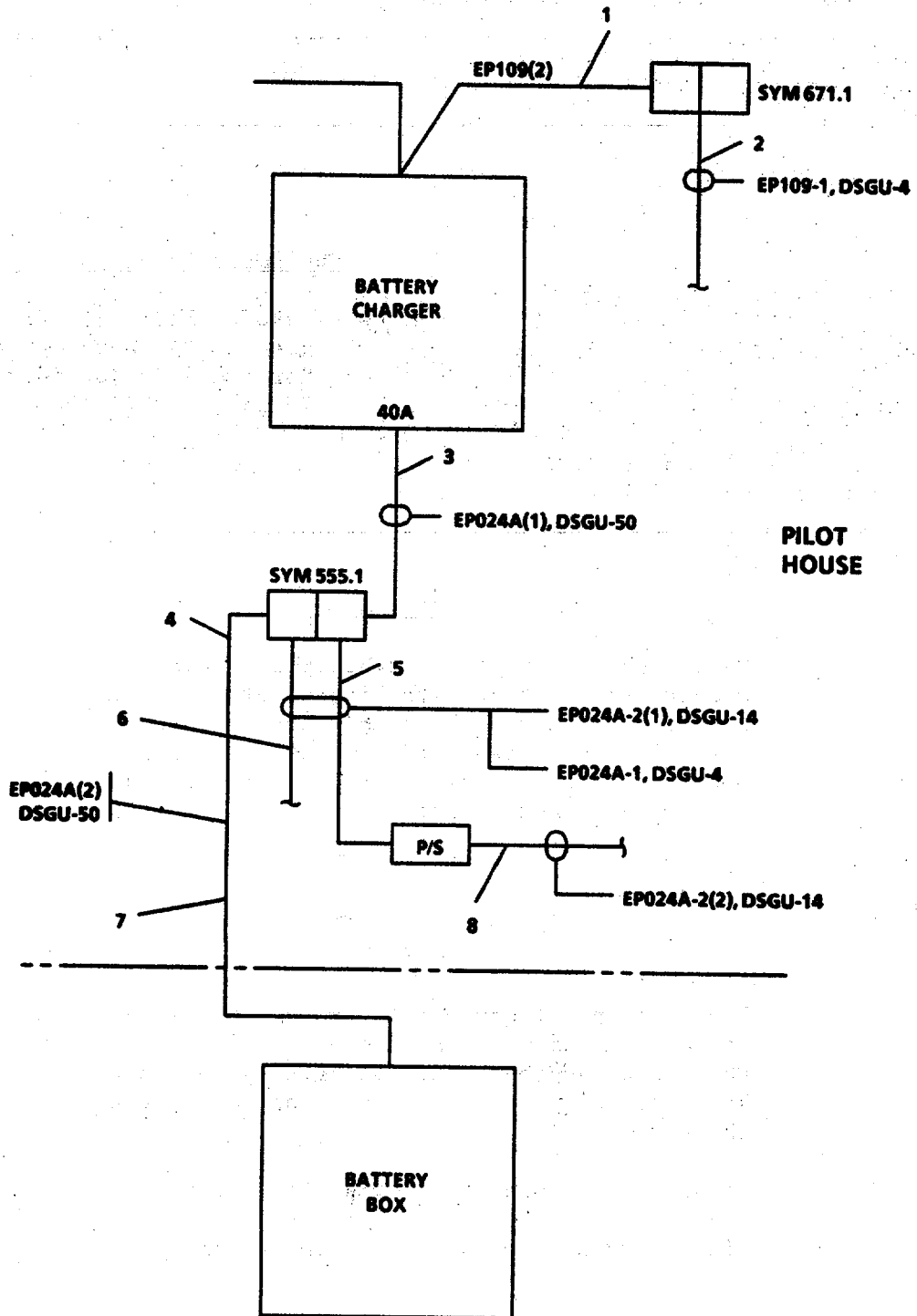

FIGURE 3-164. Pilot House Battery Assembly.

**3-182. Repair Emergency Generator Battery Assembly. (Figure 3-165)**

**This task covers:**

- a. Repair

INITIAL SETUP

Tools

Tool kit, electrician's,  
5180-00-391-1087

Materials/Parts

Warning tag, Item 1, Appendix C  
Transformer P/N IG2FI-02113A

Equipment Condition

EMERG GEN BATT CHGR EP113 25AT  
circuit breaker OFF and tagged  
"Out of Service - Do Not Operate."  
TM 55-1905-223-10.

WARNING

Death, serious injury, or equipment damage can result from contact with live electrical circuits. Before beginning work on this, or any other electrical equipment, turn power and control voltage circuit breakers OFF and tag "Out of Service - Do Not Operate."

REPAIR

NOTE

Repair of emergency generator battery assembly is by replacement of associated electrical cables (1 through 4), and by repair of battery charger. Refer to paragraph 3-141Q for repair of battery charger.

- a. Disconnect cable from, source and termination point.
- b. Run new cable. Attach to source and termination point.

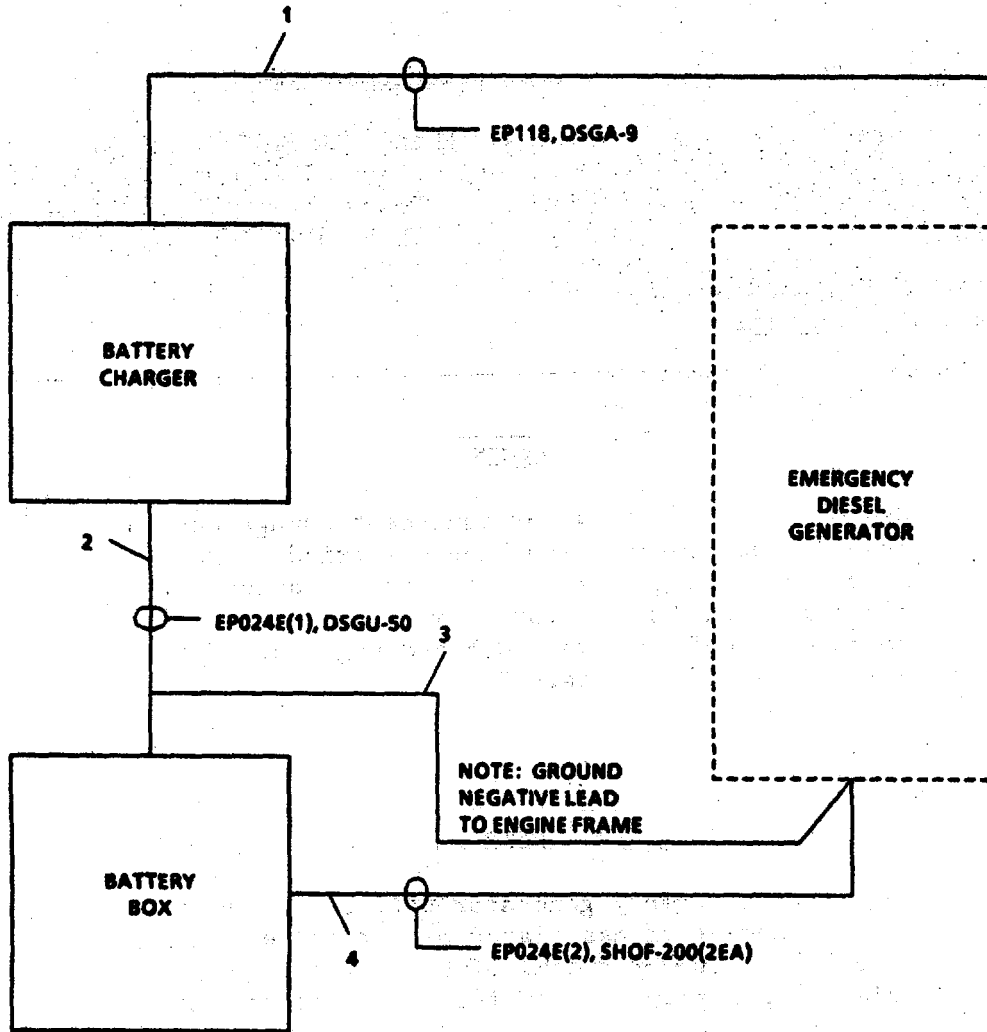

FIGURE 3-165. *Emergency Generator Battery Assembly.*  
3-584



---

**3-183. Repair Generator Number 1 Battery Assembly. (Figure 3-166)**

---

**This task covers:            Repair**

---

INITIAL SETUPTools

Tool kit, electrician's,  
5180-00-391-1087

Equipment Condition

SSGD-2 BATT CHGR EP112 40AT circuit  
breaker OFF and tagged "Out of  
Service - Do Not Operate."  
TM 55-1905-223-10.

Materials/Parts

Warning tag, Item 1, Appendix C  
Transformer P/N 113B1-02717A

---

WARNING

Death, serious injury, or equipment damage can result from contact with live electrical circuits. Before beginning work on this, or any other electrical equipment, turn power and control voltage circuit breakers OFF and tag "Out of Service - Do Not Operate."

REPAIR

## NOTE

Repair of generator number one battery assembly is by replacement of associated electrical cables (1 through 3), and by repair of battery charger. Refer to paragraph 3-141Q for repair of battery charger.

- a. Disconnect cable from source and termination point.
- b. Run new cable. Attach to source and termination point.

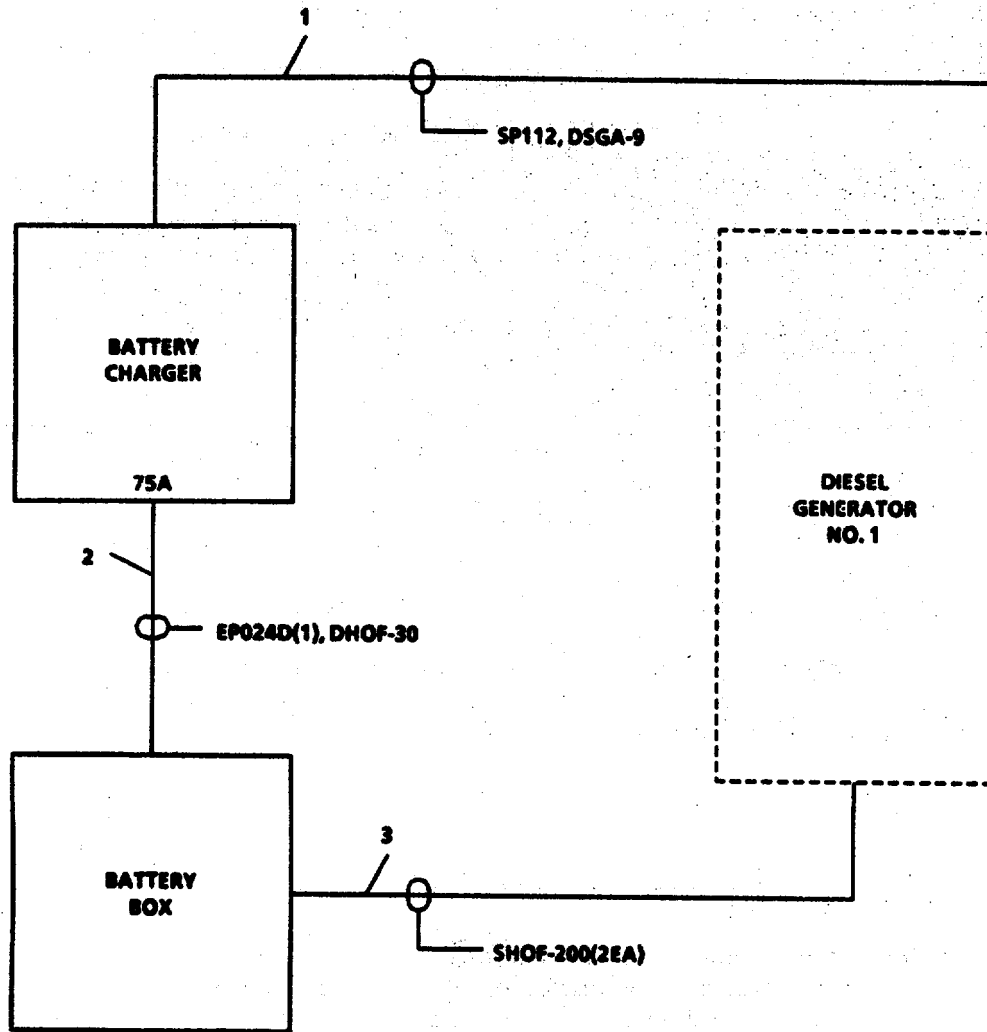

FIGURE 3-166. Generator No. 1 Battery Assembly.

---

**3-184. Repair Bow Thruster Battery Assembly. (Figure 3-167)**

---

**This task covers:            Repair**

---

INITIAL SETUPTools

Tool kit, electrician's,  
5180-00-391-1087

Materials/Parts

Warning tag, Item 1, Appendix C  
Transformer P/N 113B1-02717A

Equipment Condition

BOWTHRUSTER BATT CHGR EP111 40AT  
circuit breaker OFF and tagged  
"Out of Service - Do Not Operate."  
TM 55-1905-223-10.

WARNING

Death, serious injury, or equipment damage can result from contact with live electrical circuits. Before beginning work on this, or any other electrical equipment, turn power and control voltage circuit breakers OFF and tag "Out of Service - Do Not Operate."

REPAIR

## NOTE

Repair of bow thruster battery assembly is by replacement of associated electrical cables (1 through 5) and by repair of battery charger. Refer to paragraph 3-141Q for repair of battery charger.

- a. Disconnect cable from source and termination point.
- b. Run new cable. Attach to source and termination point.

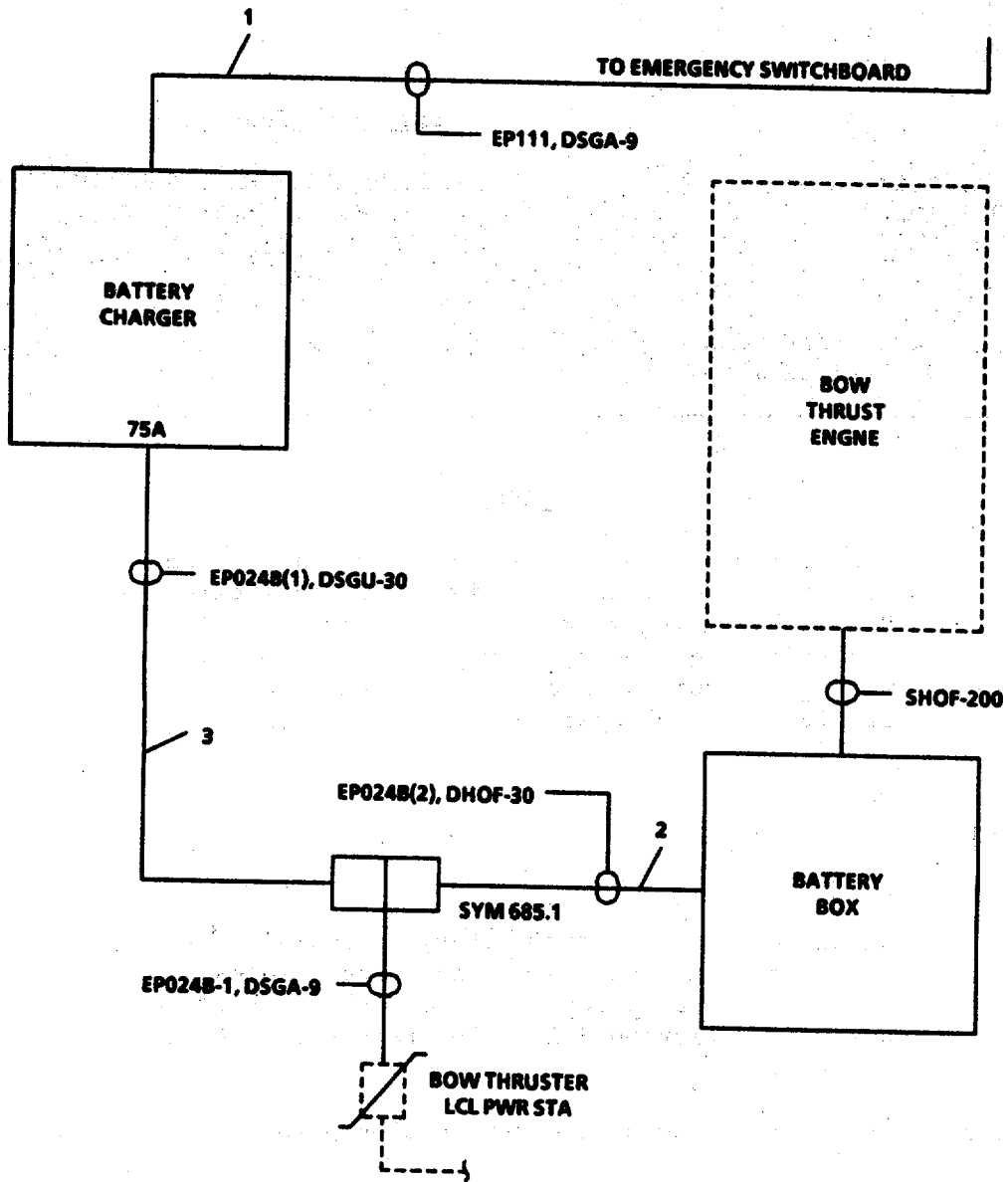

FIGURE 3-167. *Bowthruster Engine Battery Assembly.*

<b>MAINTENANCE OF DOORS, HATCHES, AND MANHOLES/WINDOWS GROUP</b>
--

---

**3-185. Repair Watertight Door, 30 x 51 (with Fixed Light). (Figure 3-168)**

---

**This task covers:**            **a. Disassembly**            **b. Repair**            **c. Assembly**

---

INITIAL SETUP
Tools

Tool kit, general mechanic's,  
5180-00-699-5273  
Torch outfit, cutting and welding  
medium duty, oxygen and acetylene,  
3433-00-357-8116  
Tool kit, welder, 5180-00-754-0661

Equipment Condition

Door removed, paragraph 2-206 .

Materials/Parts

Refer to doors, hatches, and  
manholes/windows group  
P/N 8167011, TM 55-1905-223-24P

---

DISASSEMBLY

NOTE

Disassembly/assembly procedures for both left- and right-hand doors are the same.

NOTE

Refer to TM 55-1900-204-24 for detailed cutting and welding procedures.

- a. Remove eye (8) and hasp (7) from door (1).
- b. Remove grab handle (6) from door.
- c. Remove hinge blade (2) and hinge pad (3) from door.
- d. Remove frame wedge (4) and frame angle (5) from door.

REPAIR

Repair at this level of maintenance is by replacement of defective structural parts of the door.

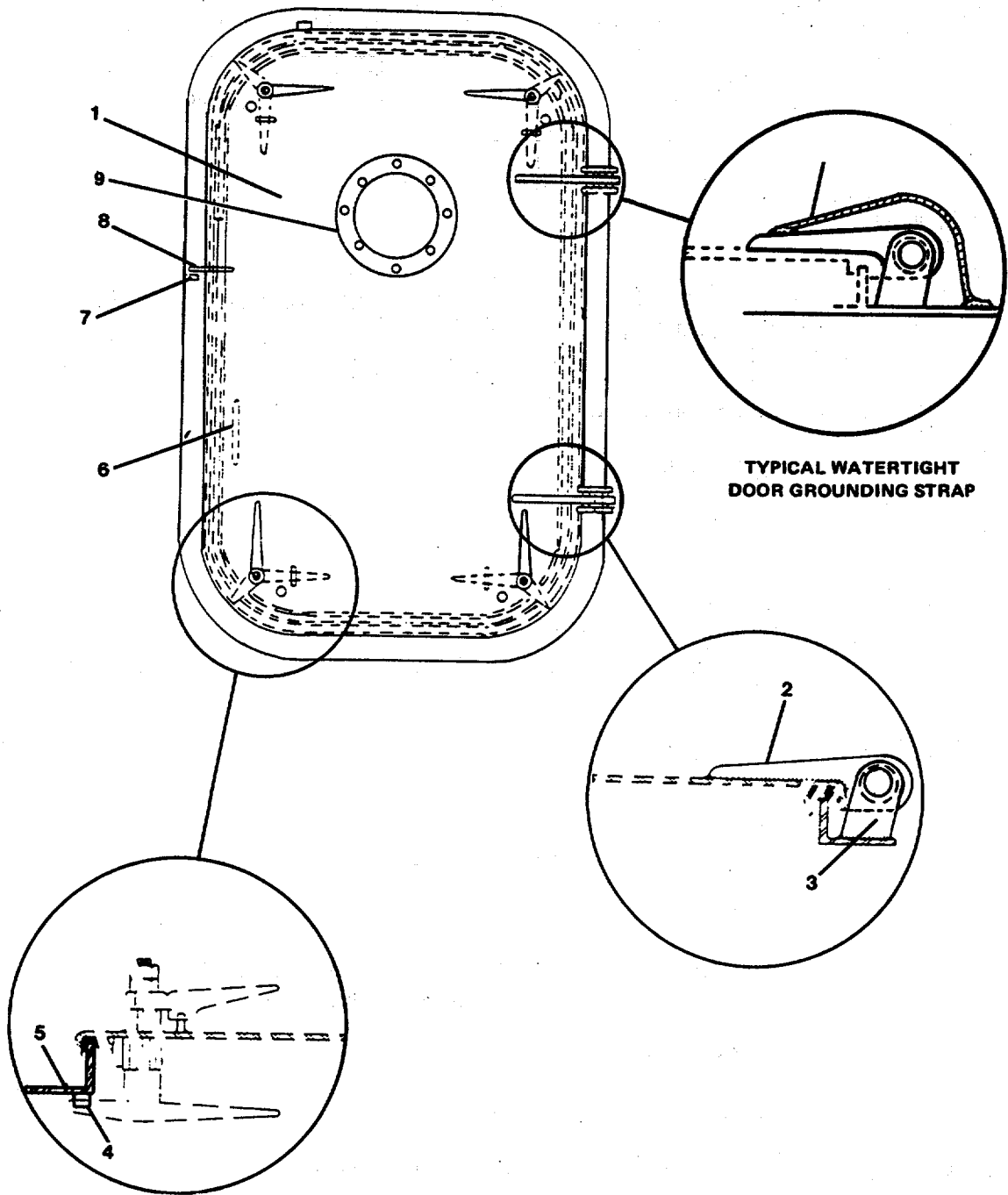

FIGURE 3-168. *Repair Watertight Door. 30 x 51 (with Fixed Light).*

ASSEMBLY

- a. Install frame angle (5) and wedge (4) on door (1).
- b. Install hinge pad (3) and hinge blade (2) on door.
- c. Install grab handle (6) on door.
- d. Install hasp (7) and eye (8) on door.
- e. Install fixed light assembly (9) on door.
- f. Install door (para. 2-206).
- g. Install (if removed in step a of removal procedures) grounding straps to hinge blades and to bulkhead.

**3-186. Repair Watertight Door (30 x 51). (Figure 3-169)**

**This task covers:**            **a. Disassembly**            **b. Repair**            **c. Assembly**

INITIAL SETUP

Tools

Tool kit, general mechanic's,  
5180-00-699-5273  
Torch outfit, cutting and welding  
medium duty, oxygen and acetylene,  
3433-00-357-8116  
Tool kit, welder, 5180-00-754-0661

Equipment Condition

Door removed, paragraph 2-207 .

Materials/Parts

Refer to doors, hatches, and  
manholes/windows group  
P/N 8167011, TM 55-1905-223-24P

DISASSEMBLY

NOTE

Disassembly/assembly procedures for both left- and right-hand doors are the same.

NOTE

Refer to TM 55-1900-204-24 for detailed cutting and welding procedures.

- a. Remove eye (8) and hasp (7) from door (1).
- b. Remove grab handle (6) from door.
- c. Remove hinge blade (2) and hinge pad (3) from door.
- d. Remove frame wedge (4) and frame angle (5) from door.

REPAIR

Repair at this level of maintenance is by replacement of defective structural parts of the door.



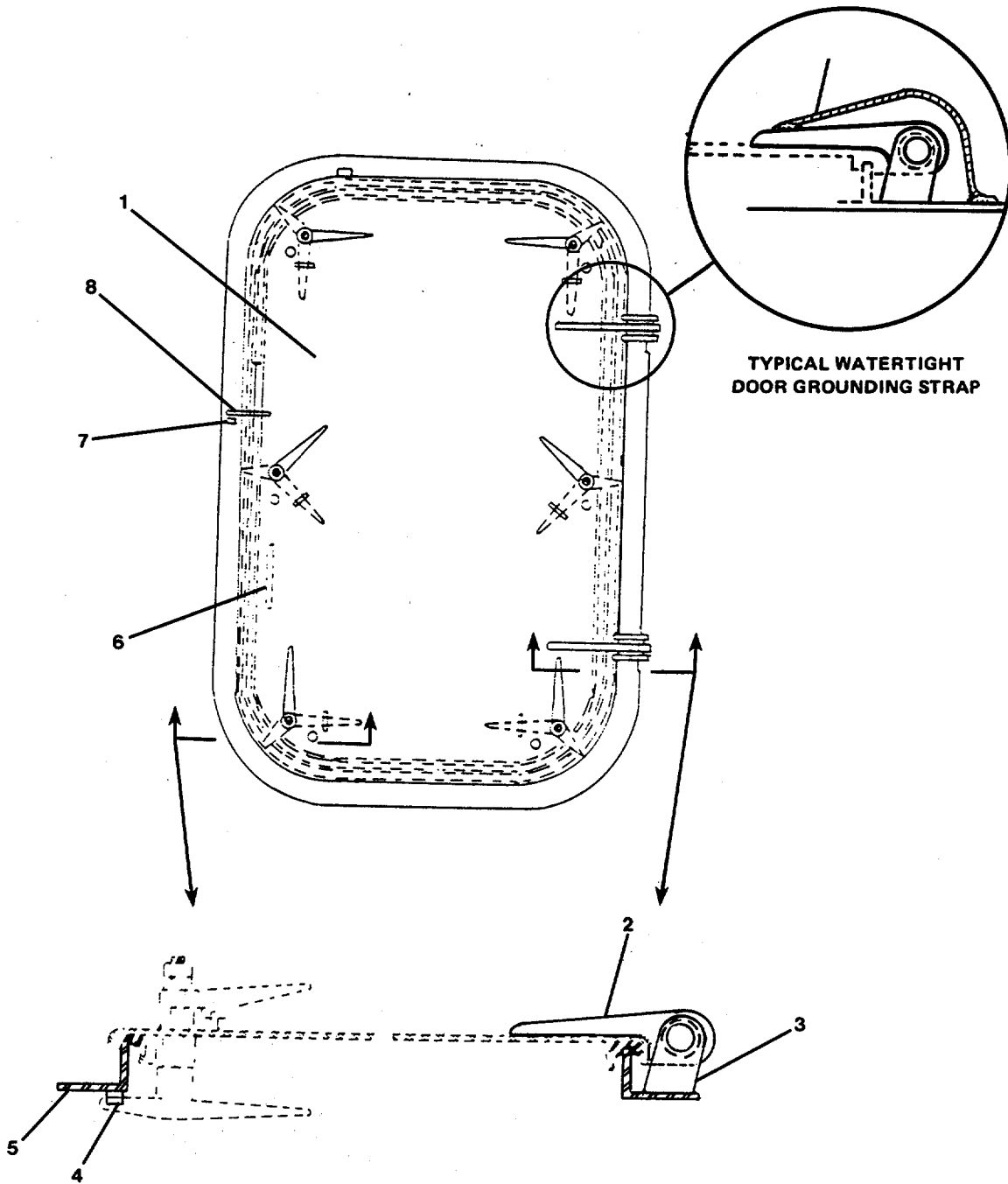

FIGURE 3-169. *Repair Watertight Door (30 x 51).*

ASSEMBLY

- a. Install frame angle (5) and frame wedge (4) on door (1).
- b. Install hinge pad (3) and hinge blade (2) on door.
- c. Install grab handle (6) on door.
- d. Install hasp (7) and eye (8) on door.
- e. Install door (para. 2-207).

---

**3-187. Repair Watertight Door, Quick Action, Left Hand (30 x 66). (Figure 3-170)**

---

**This task covers:**

- a. **Disassembly**      b. **Repair**      c. **Assembly**
- 

INITIAL SETUPTools

Tool kit, general mechanic's,  
5180-00-699-5273  
Torch outfit, cutting and welding  
medium duty, oxygen and acetylene,  
3433-00-357-8116  
Tool kit, welder, 5180-00-754-0661

Equipment Condition

Door removed, paragraph 2-208 .

Materials/Parts

Refer to doors, hatches, and  
manholes/windows group  
P/N 8167011, TM 55-1905-223-24P

---

DISASSEMBLY

## NOTE

Refer to TM 55-1900-204-24 for detailed cutting and welding procedures.

- a. Remove eye (6) and hasp (7) from door (1).
- b. Remove grab handle (8) from door.
- c. Remove hinge blade (2) from door and hinge pad (3) from frame angle (5).
- d. Remove frame wedge (4) and frame angle (5) from bulkhead.

REPAIR

Repair at this level of maintenance is by replacement of defective structural parts of the door.

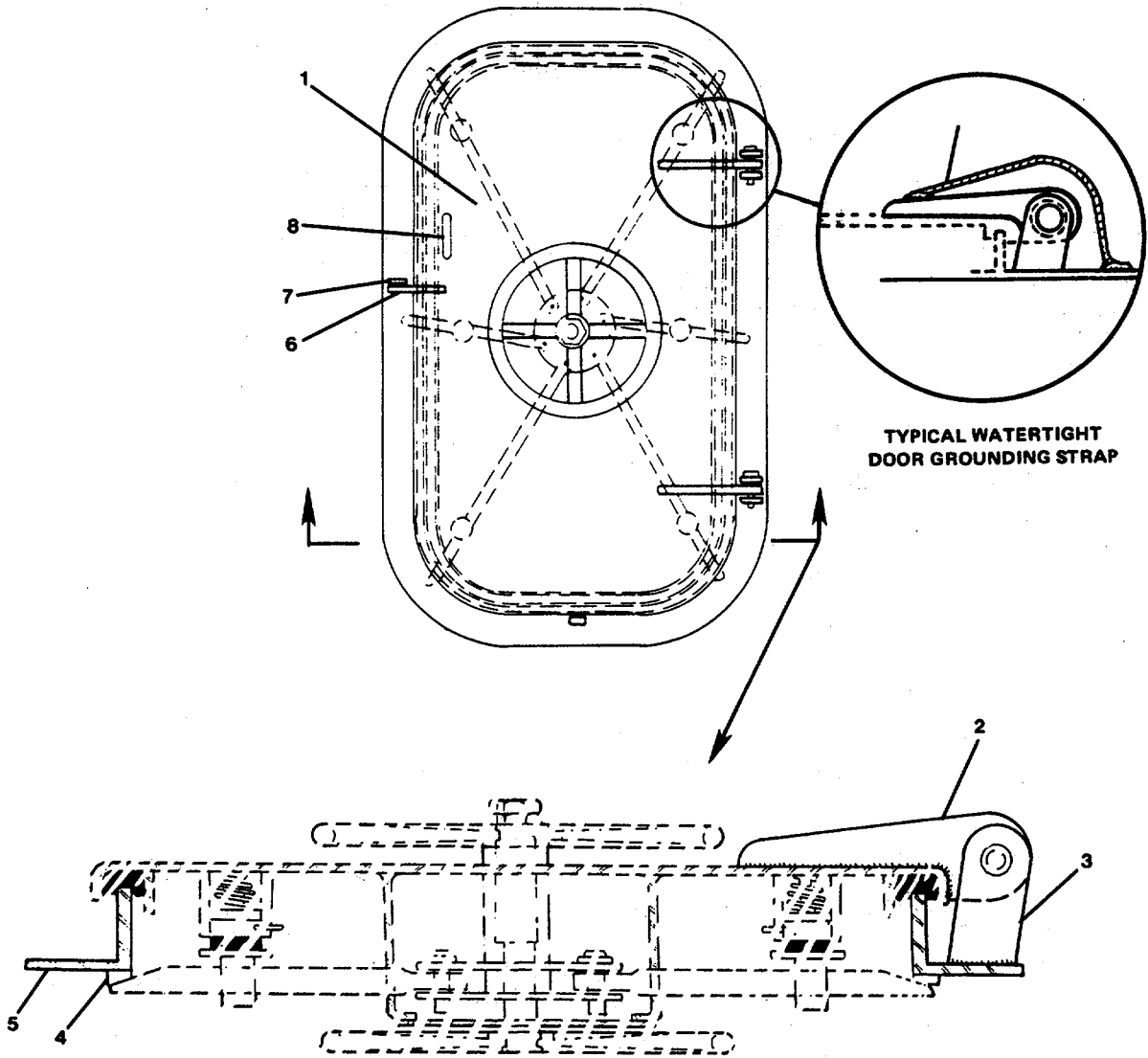

FIGURE 3-170. Repair Watertight Door, Quick Action, Left Hand (30 x 66).

ASSEMBLY

- a. Install frame angle (5) and frame wedge (4) on bulkhead.
- b. Install hinge pad (3) on frame angle (5) and hinge blade (2) on door.
- c. Install grab handle (8) on door.
- d. Install hasp (7) and eye (6) on door.
- e. Install door (para. 2-208).
- f. Install (if removed in step a of removal procedure) grounding straps to hinge blades and to bulkhead.

**3-188. Repair Watertight Door, Six Dogs (30 x 60). (Figure 3-172)**

**This task covers:**            **a. Disassembly**            **b. Repair**            **c. Assembly**

INITIAL SETUP

Tools

Tool kit, general mechanic's,  
5180-00-699-5273  
Torch outfit, cutting and welding  
medium duty, oxygen and acetylene,  
3433-00-357-8116  
Tool kit, welder, 5180-00-754-0661

Equipment Condition

Door removed, paragraph 2-209 .

Materials/Parts

Refer to doors, hatches, and  
manholes/windows group  
P/N 8167011, TM 55-1905-223-24P

DISASSEMBLY

NOTE

Disassembly/assembly procedures for both left- and right-hand doors are the same.

NOTE

Refer to TM 55-1900-204-24 for detailed cutting and welding procedures.

- a. Remove eye (7) and hasp (8) from door (1).
- b. Remove hinge blade (2) from door and hinge pad (3) from frame angle (5).
- c. Remove frame wedge (4) and frame angle (5) from bulkhead.

REPAIR

Repair at this level of maintenance is by replacement of defective structural parts of the door.

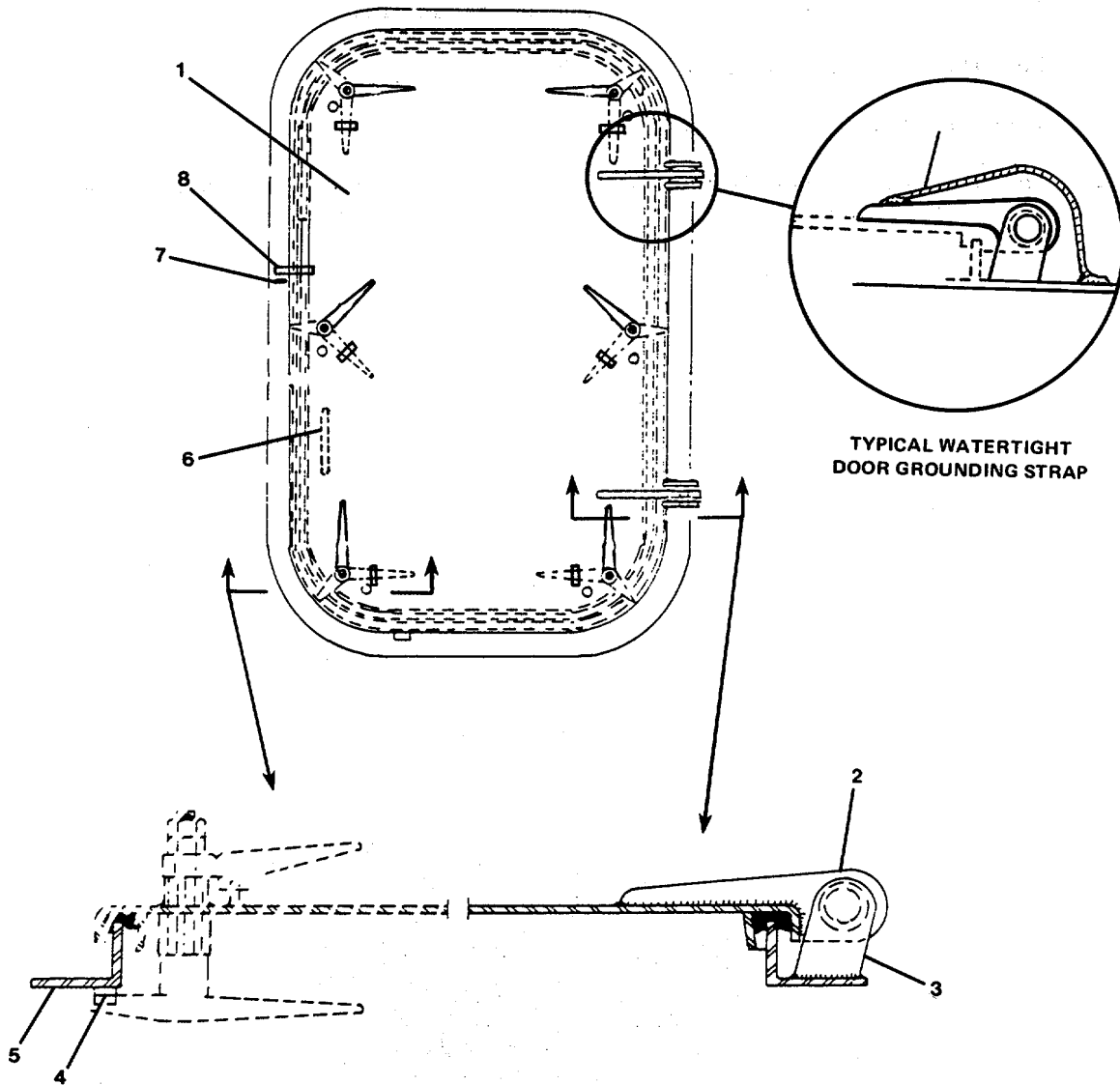

FIGURE 3-172. *Repair Watertight Door. Six Dogs (30 x 60).*

---

ASSEMBLY

---

- a. Install grab handle (6) on door (1).
- b. Install frame angle (5) and frame wedge (4) on bulkhead.
- c. Install hinge pad (3) on frame angle (5) and hinge blade (2) on door.
- d. Install hasp (8) and eye (7) on door.
- e. Install door (para. 2-209).
- f. Install (if removed in step a of removal procedure) grounding straps to hinge blades and to bulkhead.



**3-189. Repair Watertight Door, Four Dogs (30 x 60). (Figure 3-173)**

**This task covers:**            **a. Disassembly**            **b. Repair**            **c. Assembly**

INITIAL SETUP

Tools

Tool kit, general mechanic's,  
5180-00-699-5273  
Torch outfit, cutting and welding  
medium duty, oxygen and acetylene,  
3433-00-357-8116  
Tool kit, welder, 5180-00-754-0661

Equipment Condition

Door removed, paragraph 2-210 .

Materials/Parts

Refer to doors, hatches, and  
manhole/windows group  
P/N 8167011, TM 55-1905-223-24P

DISASSEMBLY

NOTE

Disassembly/assembly procedures for both left- and right-hand doors are the same.

NOTE

Refer to TM 55-1900-204-24 for detailed cutting and welding procedures.

- a. Remove eye (2) and hasp (3) from door (1).
- b. Remove grab handle (4) from door.
- c. Remove hinge blade (8) from door and hinge pad (7) from frame angle (6).
- d. Remove frame angle (6) from bulkhead.

REPAIR

Repair at this level of maintenance is by replacement of defective structural parts of the door.

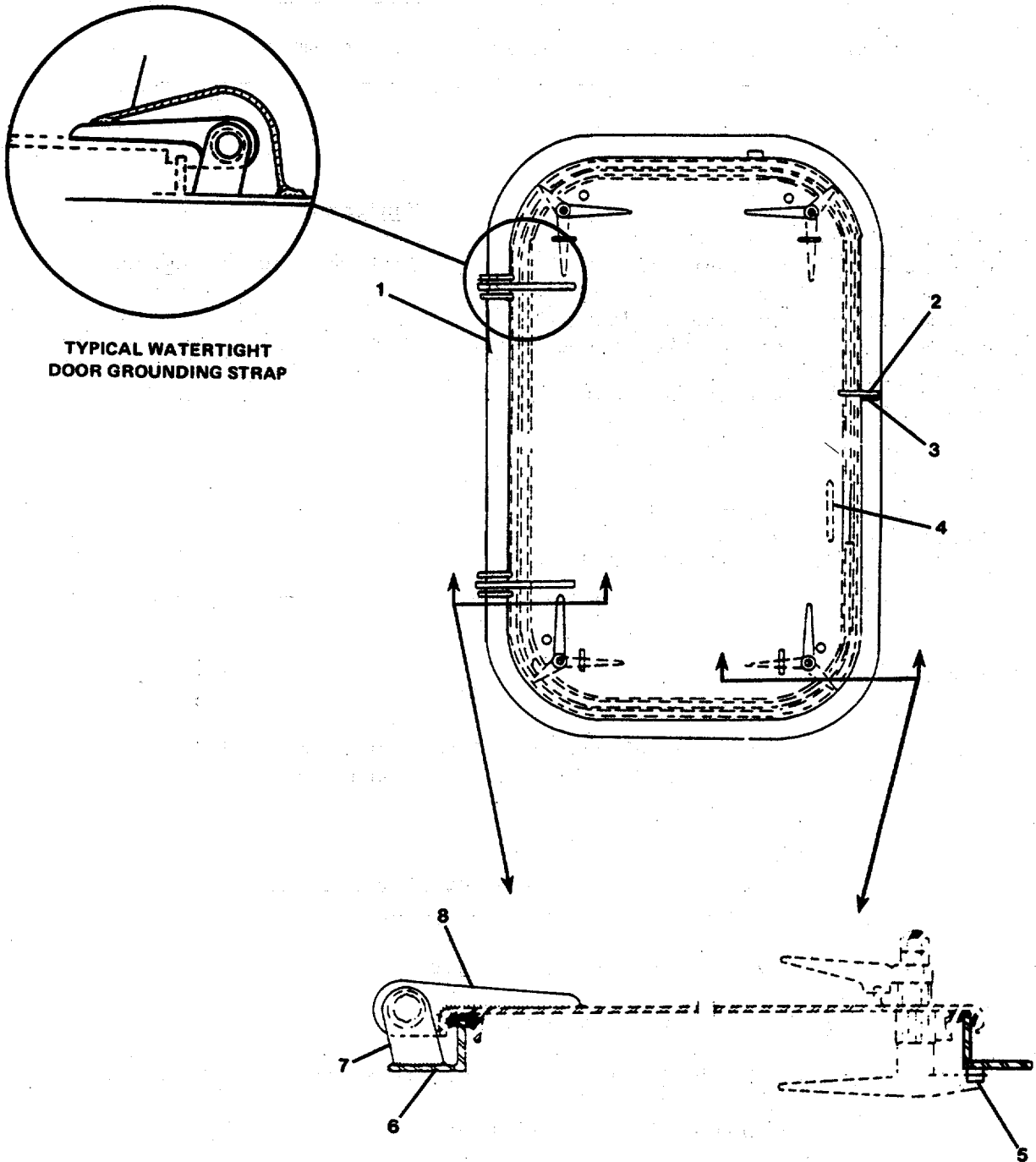

FIGURE 3-173. Repair Watertight Door. Four Dogs (30 x 60).

---

ASSEMBLY

---

- a. Install frame angle (6) on bulkhead.
- b. Install hinge pad (7) on frame angle (6) and hinge blade (8) on door.
- c. Install grab handle (4) on door.
- d. Install hasp (3) and eye (2) on door.
- e. Install door (para. 2-210).
- f. Install (if removed in step a of removal procedure) grounding straps to hinge blades and to bulkhead.

---

**3-190. Repair Watertight Hatch, Quick Action. (Figure 3-174)**

---

**This task covers:**            a. **Disassembly**            b. **Repair**            c. **Assembly**

---

INITIAL SETUPTools

Tool kit, general mechanic's,  
5180-00-699-5273  
Torch outfit, cutting and welding  
medium duty, oxygen and acetylene,  
3433-00-357-8116  
Tool kit, welder, 5180-00-754-0661

Equipment Condition

Door removed, paragraph 2-211 .

Materials/Parts

Refer to doors, hatches, and  
manholes/windows group  
P/N 8167011, TM 55-1905-223-24P

---

DISASSEMBLY

## NOTE

Refer to TM 55-190Q-204-24 for detailed cutting and welding procedures.

- a. Remove hinge blade (2) from hatch (1) and hinge pad (3) from ship structure.
- b. Remove sprocket pad (4) from ship structure.

REPAIR

Repair at this level of maintenance is by replacement of defective structural parts of the hatch.

ASSEMBLY

- a. Install sprocket pad (4) on ship structure.
- b. Install hinge pad (3) on ship structure and hinge blade (2) on hatch (1).
- d. Install hatch (para. 2-211).

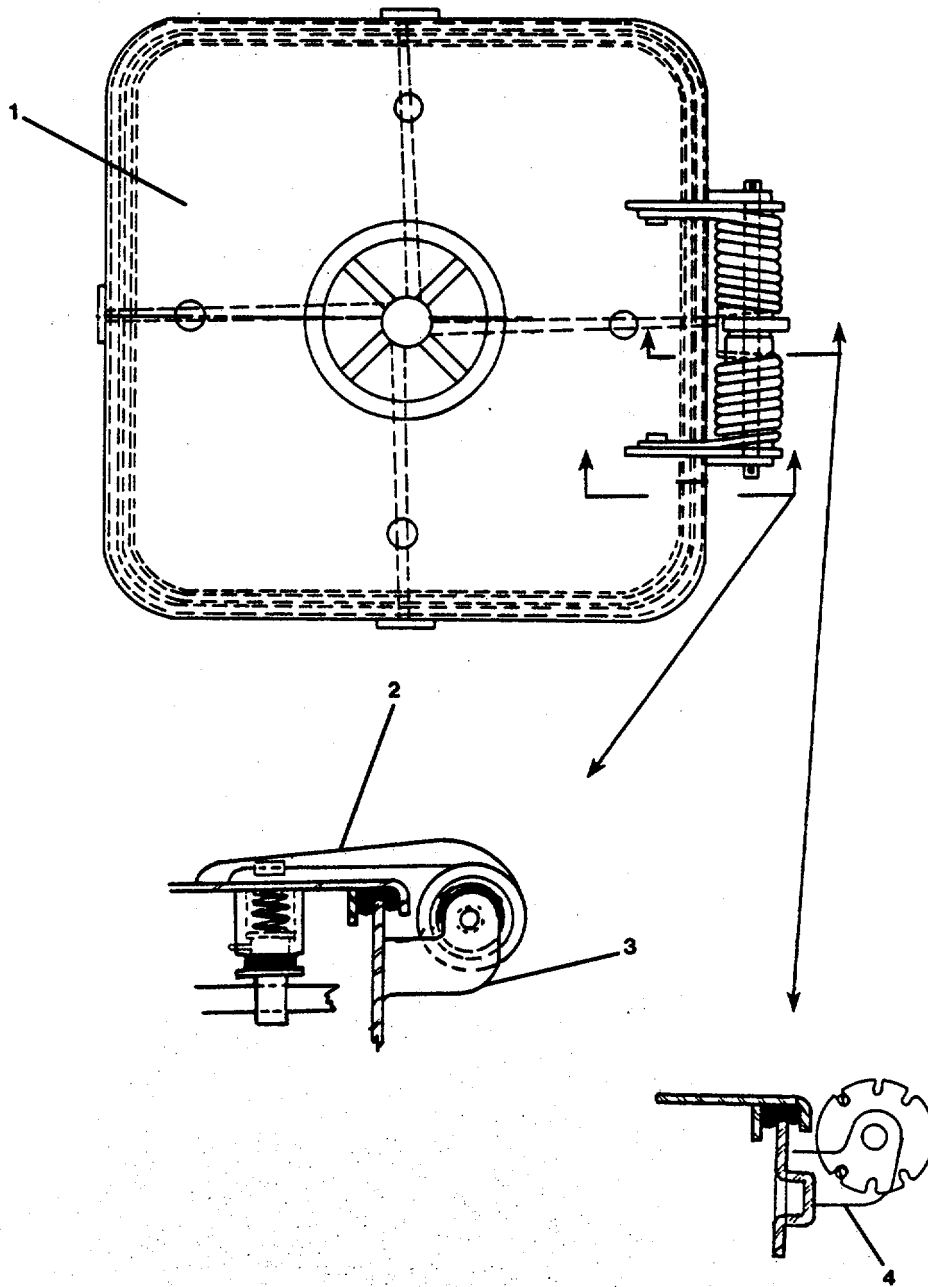

FIGURE 3-174. Repair Watertight Hatch. Quick Action.

---

**3-191. Repair Watertight Scuttle, Quick Action (Flush). (Figure 3-175)**

---

**This task covers:**

- a. **Disassembly**                      b. **Repair**                                      c. **Assembly**
- 

INITIAL SETUPTools

Tool kit, general mechanic's,  
5180-00-699-5273  
Torch outfit, cutting and welding  
medium duty, oxygen and acetylene,  
3433-00-357-8116  
Tool kit, welder, 5180-00-754-0661

Equipment Condition

Scuttle removed, paragraph 2-212.

Materials/Parts

Refer to doors, hatches, and  
manholes/windows group  
P/N 8167011, TM 55-1905-223-24P

---

DISASSEMBLY

## NOTE

Refer to TM 55-1900-204-24 for detailed cutting and welding procedures.

- a. Remove hinge pad (3) from coaming (2)
- b. Remove coaming (2) from ship structure.

REPAIR

Repair at this level of maintenance is by replacement of defective structural parts of the scuttle.

ASSEMBLY

- a. Install coaming (2) on ship structure.
- b. Install hinge pad (3) on coaming (2).
- c. Install scuttle (para. 2-212).

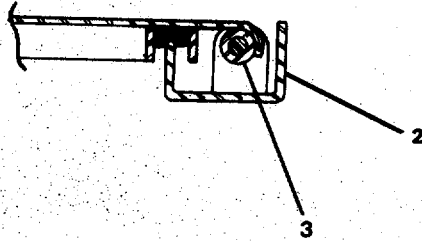
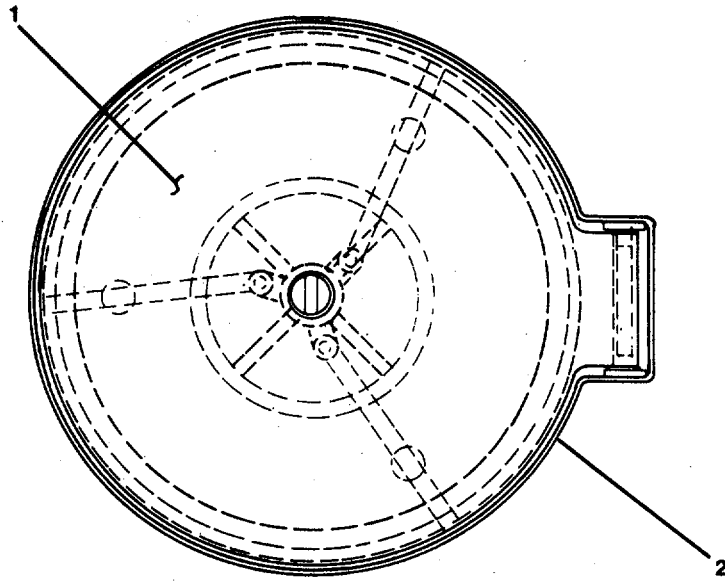

FIGURE 3-175. Repair Watertight Scuttle. Quick Action (Flush).

---

**3-192. Repair Watertight Scuttle, Quick Action (Raised). (Figure 3-176)**

---

**This task covers:**            **a. Disassembly**            **b. Repair**            **c. Assembly**

---

---

INITIAL SETUPTools

Tool kit, general mechanic's,  
5180-00-699-5273  
Torch outfit, cutting and welding  
medium duty, oxygen and acetylene,  
3433-00-357-8116  
Tool kit, welder, 5180-00-754-0661

Equipment Condition

Scuttle, removed, paragraph 2-213 .

Materials/Parts

Refer to doors, hatches, and  
manholes/windows group  
P/N 8167011, TM 55-1905-223-24P

---

---

DISASSEMBLY

## NOTE

Refer to TM 55-1900-204-24 for detailed cutting and welding procedures.

- a. Remove hinge blade (2) from scuttle and hinge pad (3) from coaming (4).
- b. Remove coaming (4) from ship structure.

---

REPAIR

Repair at this level of maintenance is by replacement of defective structural parts of the scuttle.

---

ASSEMBLY

- a. Install coaming (4) on ship structure.
- b. Install hinge pad (3) on coaming (4) and hinge blade (2) on scuttle (1).
- c. Install scuttle, paragraph 2-213 .



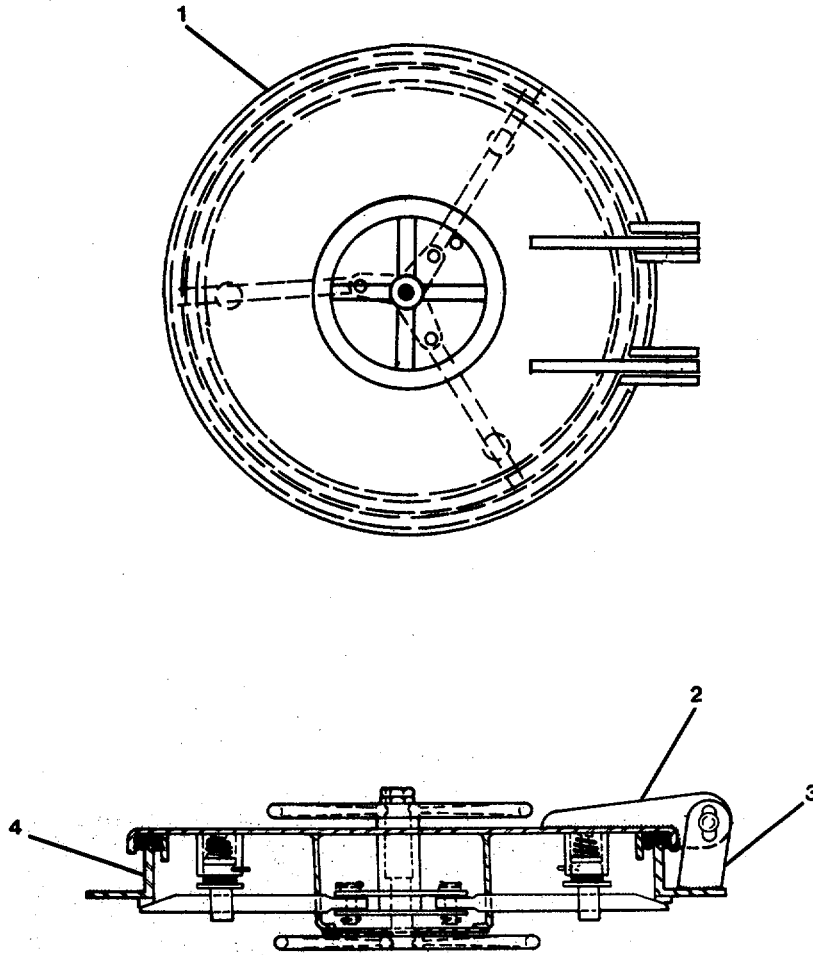

FIGURE 3-176. Repair Watertight Scuttle. Quick Action (Raised).

---

**3-193. Repair Fixed Window, Double Pane.**

---

**This task covers:**

- |                    |                       |                  |
|--------------------|-----------------------|------------------|
| <b>a. Removal</b>  | <b>b. Disassembly</b> | <b>c. Repair</b> |
| <b>d. Assembly</b> | <b>e. Replacement</b> |                  |
- 

INITIAL SETUPTools

Tool kit, general mechanic's,  
5180-00-699-5273

Materials/Parts

Sealing tape P/N 91-7790-0000  
Adhesive sealant P/N 91-0047-0000  
Glazing gasket P/N KS-16184  
Rubber strip P/N 1140  
Window glass (heat treated)  
P/N KS-25537-8  
Window glass (wire insert)  
P/N KS-25537-9

---

REMOVALWARNING

Care must be taken while handling windows to prevent personal injury or equipment damage.

- Support fixed windows (4, Figure 3-177).
- Remove self-locking nuts (1), capscrews (2), and flat washers (3).
- Remove fixed windows (4) from bulkhead.

DISASSEMBLY

- Clean off old adhesive sealant (1, Figure 3-178) and sealing tape (2) from around bulkhead opening.
- Remove glazing gaskets (6, 7) from window frames (3, 10).
- Carefully remove (heat treated) window glass (5) and (wire inserted) window glass (8) from window frames (3, 10).

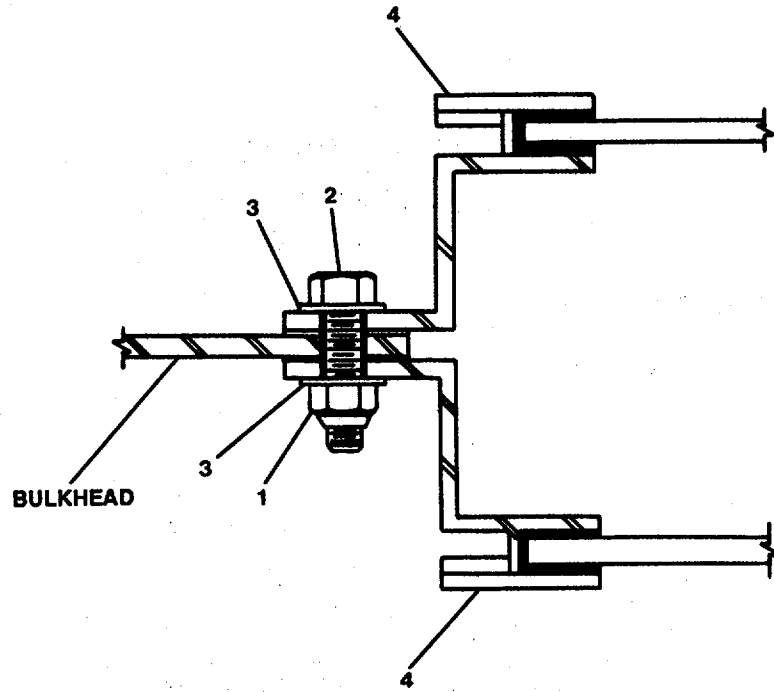

FIGURE 3-177. *Remove Fixed Window. Double Pane.*

NOTE

If window glass is to be replaced disregard the following step.

- d. Clean off old rubber strips (4, 9) from window glass (5, 8).

REPAIR

Repair at this level of maintenance is by replacement of: sealing tape (2), adhesive sealant (1), window glass (heat treated) (5), window glass (wire inserted) (8), glazing gaskets (6, 7), and rubber strips (4, 9).

ASSEMBLY

- a. Apply new rubber strips (4, 9) on window glass (5, 8).
- b. Install (heat treated) window glass (5) and (wire inserted) window glass (8) in window frames (3, 10).
- c. Insert glazing gaskets (6,7) in window frames (3, 10).
- d. Apply sealing tape (2) and adhesive sealant (1) around bulkhead opening.

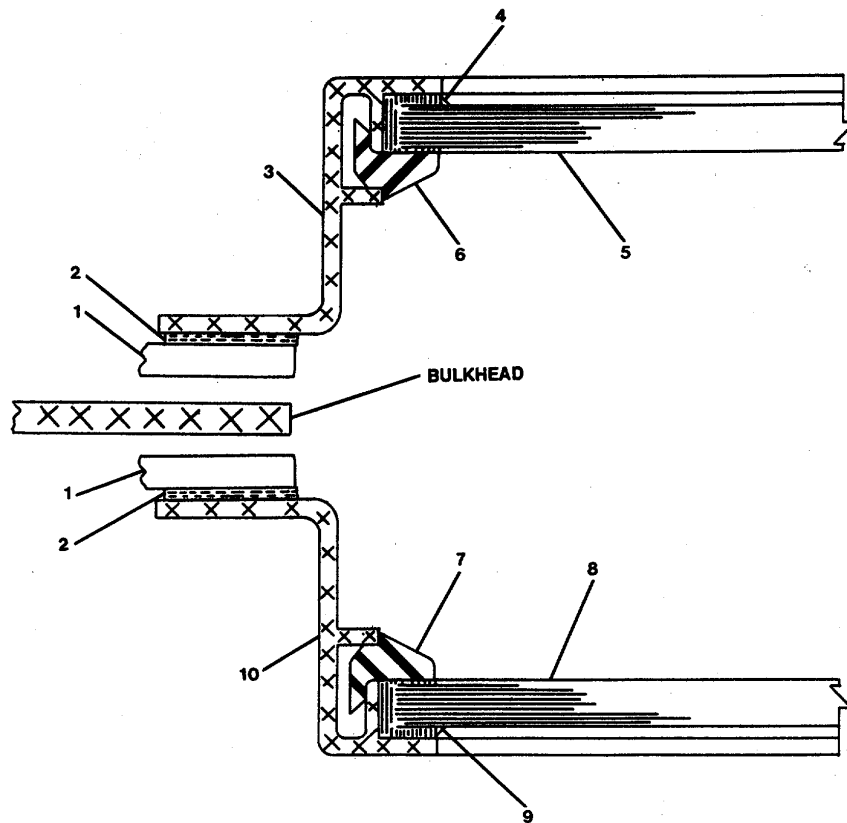

FIGURE 3-178. *Repair Fixed Window. Double Pane.*

REPLACEMENT

NOTE

Be sure to install heat treated window glass on outside of engine operating station bulkhead.

- a. Position fixed windows (4, Figure 3-177) in bulkhead opening.
- b. Secure using cap screws (2), flat washers (3), and self-locking nuts (1).

**3-194. Replace/Repair Fixed Window, With Rotary Window.**

**This task covers:**

- |                                   |  |                  |
|-----------------------------------|--|------------------|
| <p>a. Removal<br/>d. Assembly</p> | <p>b. Disassembly<br/>e. Replacement</p> | <p>c. Repair</p> |
|-----------------------------------|--|------------------|

INITIAL SETUP

Tools

Tool kit, electrician's,  
5180-00-391-1087  
Tool kit, general mechanic's  
5180-00-699-5273

Equipment Condition

At EL 102 panel, set clearview screen  
heater switch to the OFF position.  
Tag "Out of Service - Do Not  
Operate."

Materials/Parts

Sealing tape P/N 91-7790-0000  
Adhesive sealant P/N 91-0047-0000  
Glazing gasket P/N KS-16184  
Window glass (heat treated)  
P/N KS-25537-6  
Rubber strip P/N 1139  
Junction box P/N KS-23560-6  
Fixed glass P/N KS-23560-8  
DC motor P/N KS-23560-10  
Motor brushes P/N KS-23560-15  
Cable feed tube P/N KS-23560-12  
Defroster4heater P/N KS-23560-11  
Rotating glass P/N KS-23560-7  
Gasket P/N KS-23560-14  
Warning tags, Item 1, Appendix C

REMOVAL

WARNING

Window assembly weighs approximately 100 pounds. To prevent personal injury at least two soldiers should handle window.

Prior to working on window, ensure that all switches and circuit breakers are placed in the OFF position.

- a. Remove screw (3, Figure 3-179) and junction box cover (2) from junction box (1).
- b. Tag and disconnect electrical wiring at terminal block.
- c. Remove self-locking nuts (8), capscrews (7), and washers (6) from window frame.

**CAUTION**

To prevent equipment damage. Care must be taken while handling window.

- d. Carefully remove rotary window assembly (9) from bulkhead opening.
- e. Clean off old sealant adhesive (5) and sealing tape (4) from around bulkhead opening and window frame.

**DISASSEMBLY**

**CAUTION**

To prevent equipment damage. Care must be taken while handling window.

- a. Disassemble rotary window assembly as follows:

**NOTE**

To remove rotating glass, hold glass firmly while turning the rotating cap counterclockwise.

- (1) Remove rotating cap (13, Figure 3-180).
- (2) Carefully remove rotating glass (12).
- (3) Remove frame retaining bezel ring (6).
- (4) Carefully remove fixed glass (7) with motor (10) attached.
- (5) Remove bezel ring (8) and motor (10) from fixed glass (7).
- (6) Remove cable feed tube (14) from motor (10).
- (7) Remove screws (11), junction box (5), and retaining ring (4).
- (8) Remove frame ring (2) from fixed window assembly.
- (9) Remove gasket (3) from around frame ring (2).
- (10) Remove defroster/heater (1) from frame ring (2).
- (11) Remove back plate of motor (10).
- (12) Inspect brushes (9) and replace as necessary.

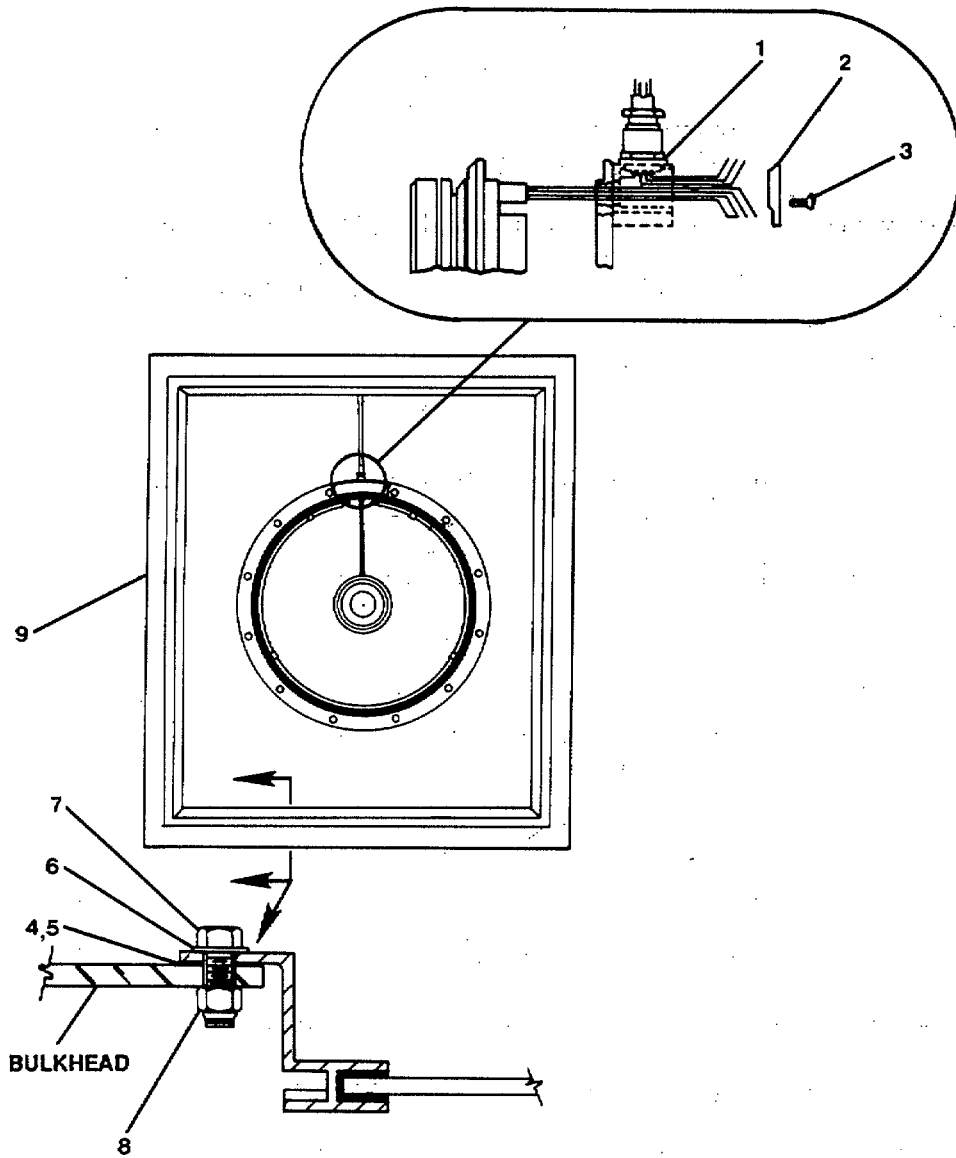

FIGURE 3-179. *Replace Fixed Window, with Rotary Window.*



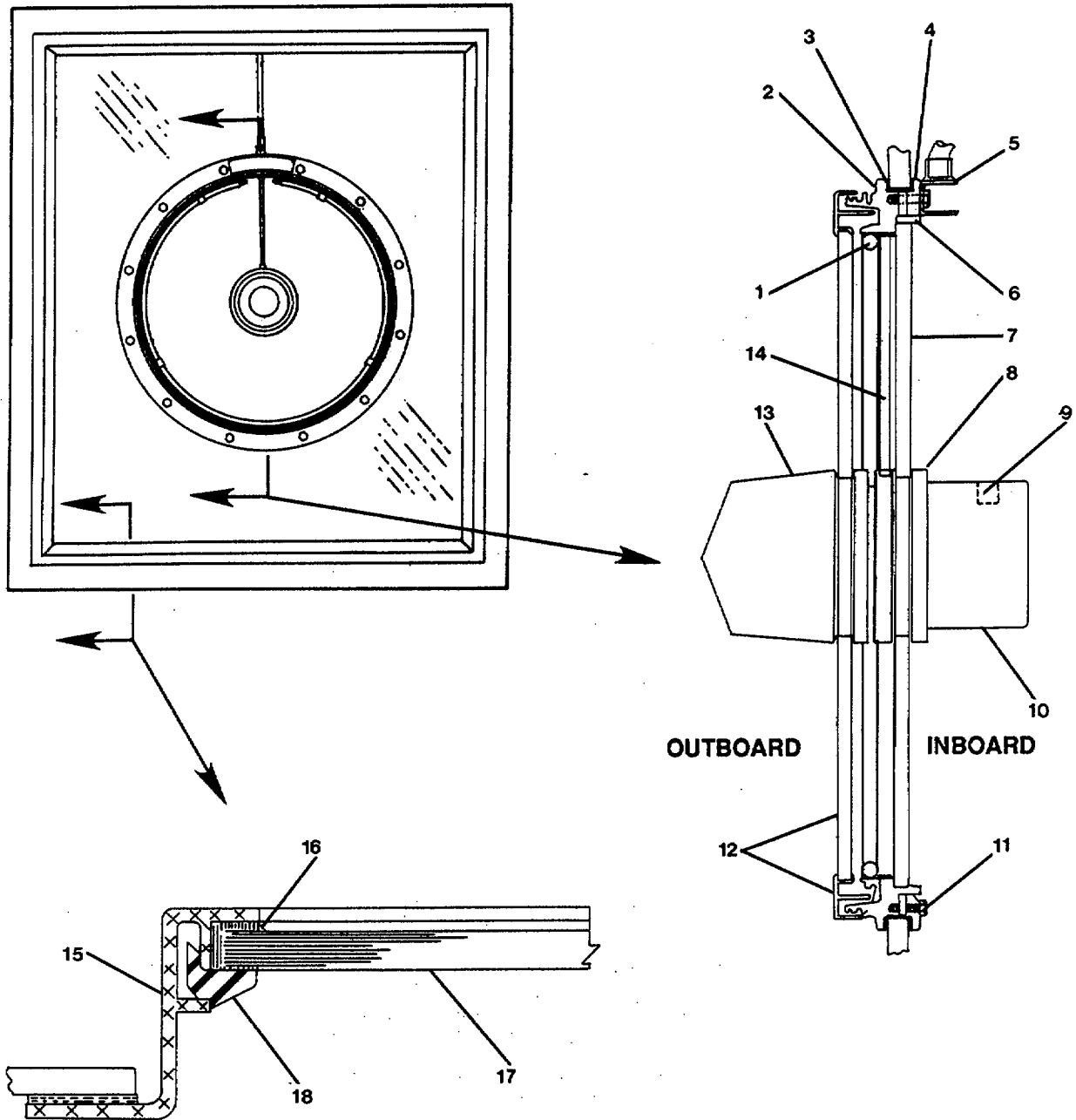

FIGURE 3-180. *Repair Fixed Window, With Rotary Window.*

b. Disassemble fixed window assembly as follows:

- (1) Remove glazing gasket (18) from window frame (15).
- (2) Carefully remove (heat treated) window glass (17) from window frame.

**NOTE**

If window glass is to be replaced disregard the following step.

- (3) Clean off old rubber strip (16) from window glass (17).

**REPAIR**

Repair at this level of maintenance is by replacement of: sealing tape(4), adhesive sealant (5), glazing gasket (18), (heat treated) window glass (17), rubber strip (16), junction box (5), fixed glass (7), d.c. motor (10), motor brushes (9), cable feed tube (12), defroster/heater (1), rotating glass (12), and gasket (3).

**ASSEMBLY**

**WARNING**

Care must be taken while handling windows to prevent personal injury or equipment damage.

a. Assemble fixed window assembly as follows:

- (1) Install rubber strip (16) on window glass (17).
- (2) Carefully install (heat treated) window glass (17) in window frame (15).
- (3) Insert glazing gasket (18) in window frame.

b. Assemble rotary window assembly as follows:

- (1) Install defroster/heater (1) in frame ring (2).
- (2) Install gasket (3) around frame ring (2).
- (3) Position frame ring (2) in fixed window assembly.
- (4) Install retaining ring (4), junction box (5), and secure using screws (11).
- (5) Install cable feed tube (14) in motor (10).
- (6) Install back plate on motor (10).
- (7) Inspect drain holes at the bottom of the frame ring (2) for obstructions prior to installing glass.
- (8) Clear drain holes as necessary.

- (9) Place fixed glass (7) on motor (10) and secure using bezel ring (8).

**NOTE**

Be sure glass is clean on both sides before installing.

- (10) Place fixed glass (7) with motor (10) in frame ring (2) and secure using frame retaining bezel ring (6).

**NOTE**

To install rotating glass hold glass firmly while turning the rotating cap clockwise.

- (11) Install rotating glass (12) and secure using rotating cap (13).

**REPLACEMENT**

- a. Apply sealing tape (4, Figure 3-179) and sealant adhesive (5) around bulkhead opening and window frame.

**WARNING**

Window assembly weighs approximately 100 pounds. To prevent personal injury at least two soldiers should handle window.

- b. Carefully place rotary window assembly (9) in position.
- c. Install washers (6), capscrews (7), and self-locking nuts (8).
- d. Remove tags and connect electrical wiring at terminal block.
- e. Install junction box cover (2) on junction box (1).
- f. Secure cover using screw (3).
- g. Remove tag and turn clearview screen heater Switch to the ON position.
- h. Check rotary window assembly for proper operation.

---

**3-195. Replace/Repair Fixed Window, Right/Left Hand.**

---

This task covers:

- |             |                |           |
|-------------|----------------|-----------|
| a. Removal  | b. Disassembly | c. Repair |
| d. Assembly | e. Replacement |           |
- 

---

**INITIAL SETUP**

---

Tools

Tool kit, general mechanic's,  
5180-00-699-5273

Materials/Parts

Sealing tape P/N 91-7790-0000  
Adhesive sealant P/N 91-0047-0000  
Glazing gasket P/N KS-16184  
Window glass (heat treated)  
P/N KS-25547  
Rubber-strip P/N 1139

---

---

**REMOVAL**

---

**NOTE**

Procedures are the same for both right and left hand windows.

- a. Support fixed window (1, Figure 3-181).

**WARNING**

Care must be taken while handling windows to prevent personal injury or equipment damage.

- b. Remove self-locking nuts (2), capscrews (4), and flat washers (3).
- c. Remove fixed window (1) from bulkhead opening.

**3-620**

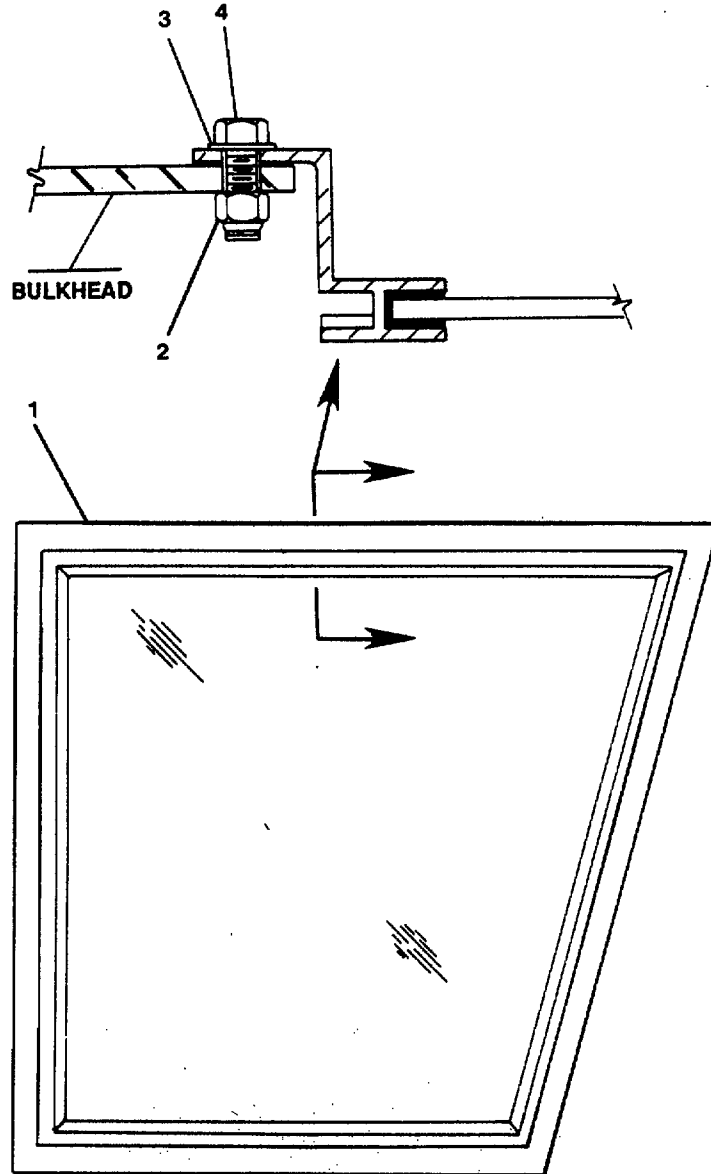

FIGURE 3-181. Replace Fixed Window, Right/Left Hand.

**DISASSEMBLY**

- a. Clean off old sealant adhesive (1, Figure 3-182) and sealing tape (2) from around bulkhead opening.
- b. Remove glazing gasket (6) from window frame (3).
- c. Carefully remove (heat treated) window glass (5) from window frame (3).

**NOTE**

IF window is to be replaced,: disregard the following step.

- d. Clean off old rubber strip (4) from window glass (5).

**REPAIR**

Repair at this level of maintenance is by replacement of: sealing tape (2), adhesive sealant (1), glazing gasket (6), heat treated window glass (5), and rubber strip (4).

**ASSEMBLY**

- a. Apply rubber strip (4) on window glass (5).
- b. Install (heat treated) window glass (5) in window frame (3).
- c. Insert glazing gasket (6) in window frame.
- d. Apply sealing tape (2) and adhesive sealant (1) around bulkhead opening.

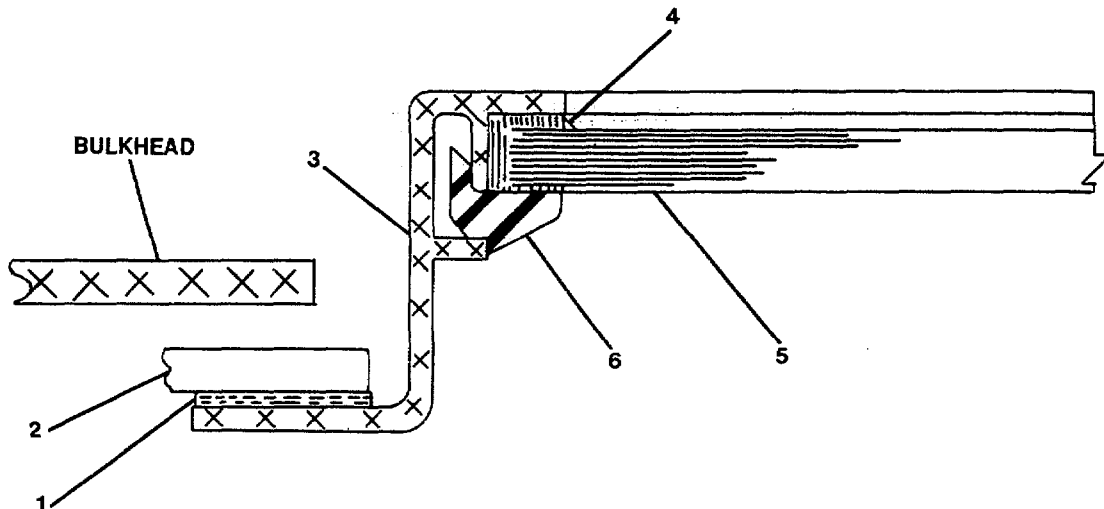

FIGURE 3-182. Repair Fixed Window, Right/Left-Hand.

**REPLACEMENT**

- a. Position fixed window (1, Figure 3-155) in bulkhead opening.
- b. Support window while-installing hardware.
- c. Install flat washers (3), capscrews (4), and self-locking nuts (2).

**3-623**

---

**3-196. Replace/Repair Fixed Window, Single Pane.**

---

**This task covers:**

- |             |                |           |
|-------------|----------------|-----------|
| a. Removal  | b. Disassembly | c. Repair |
| d. Assembly | e. Replacement |           |
- 

**INITIAL SETUP****Tools**

Tool kit, general mechanic's,  
5180-00-699-5273

**Materials/Parts**

Sealing tape P/N 91-7790-0000  
Adhesive sealant P/N 91-0047-0000  
Glazing gasket P/N KS-16184  
Window glass (heat treated)  
P/N KS-25537-5  
Rubber strip P/N 1139

---

**REMOVAL**

- a. Support fixed window (1, Figure 3-133).

**WARNING**

Care must be taken while handling windows to prevent personal injury or equipment damage.

- b. Remove self-locking nuts (2), capscrews (4), and flat washers (3).
- c. Remove fixed window (1) from bulkhead.

**3-624**



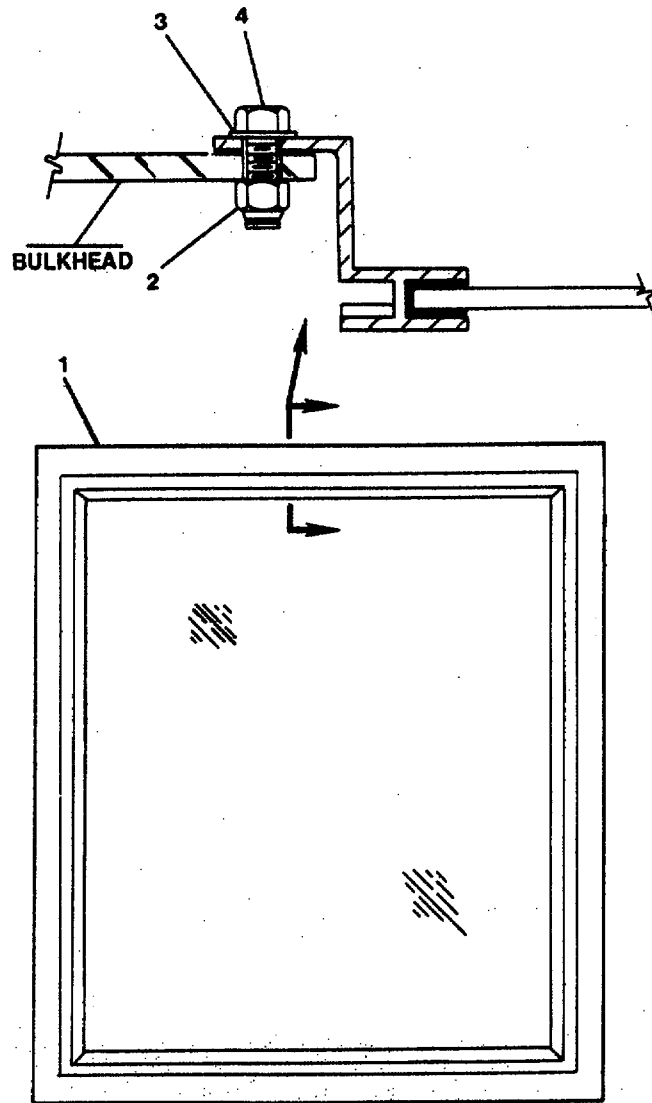

FIGURE 3-183. *Replace Fixed Window, Single Pane.*

**DISASSEMBLY****WARNING**

Care must be taken while handling windows to prevent personal injury or equipment damage.

- a. Clean off old adhesive sealant (1, Figure 3-184) and sealing tape (2) from around bulkhead opening.
- b. Remove glazing gasket (6) from window frame (3).
- c. Carefully remove (heat treated) window glass (5) from window frame (3).

**NOTE**

If window glass is to be replaced disregard the following step.

- d. Clean off old rubber strip (4) from window glass (5).

**REPAIR**

Repair at this level of maintenance is by -replacement of: sealing tape (2), adhesive sealant (1), glazing gasket (6), (heat treated) window glass (5), and rubber strip (4).

**ASSEMBLY**

- a. Apply rubber strip (4) on window glass (5).
- b. Install (heat treated) window glass (5) in window frame (3).
- c. Insert glazing gasket (6) in window frame (3).
- d. Apply sealing tape (2) and sealant adhesive (1) around bulkhead opening.

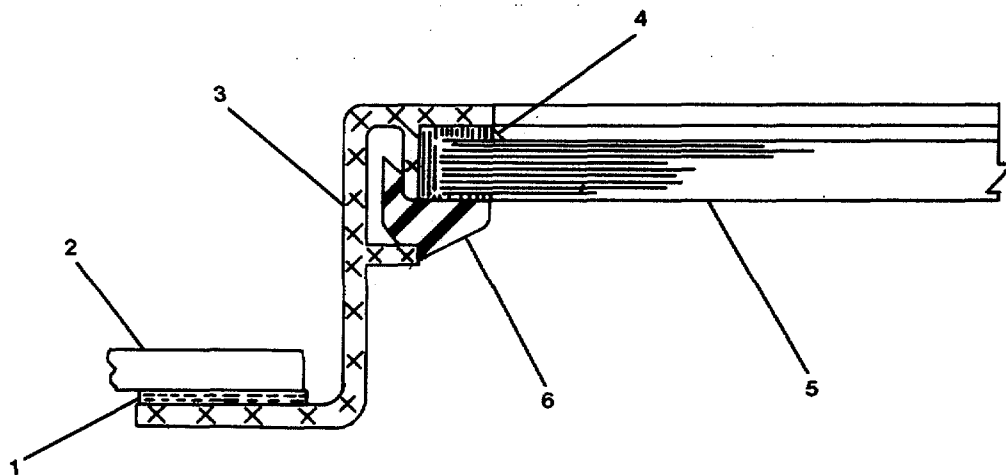

FIGURE 3-184. Repair Fixed-Window, Single Pane.

**REPLACEMENT**

- a. Position fixed window (1, Figure 3-183) in bulkhead opening.
- b. Support window while securing.
- c. Secure fixed window (1) using flat washers (3), capscrews (4, and selflocking nuts (2).

**3-627**

<b>MAINTENANCE OF LASHING GEAR EQUIPMENT</b>
--

---

**3-197. Replace Lashing Gear Sockets. (Figure 3-185)**

---

This task covers:

a. Removal

b. Repair

c. Replacement.

---

**INITIAL SETUP:**
Tools

Tool kit, welders,  
5180-00-754-0661 removed.  
Burning torch outfit,  
3433-00-357-8116  
Arc welding machine  
P/N 1341-0354

Equipment Condition

Lashing gear and toggle assembly

---

**REMOVAL**

- a. Using a burning torch, remove lashing socket (1).
- b. Using a burning torch, remove single flush, shallow deck socket (2).
- c. Using a burning torch, remove double flush, shallow deck socket (3).

---

**REPAIR**

Repair at this level of maintenance is by replacement of worn or defective parts.

---

**REPLACEMENT**

- a. Using an arc welding machine, install lashing socket (1).
- b. Using an arc welding machine, install single flush, shallow deck socket (2).
- c. Using an arc welding machine, install double flush, shallow deck socket (3).

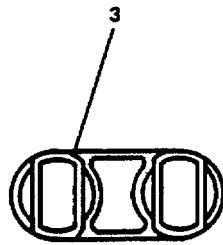
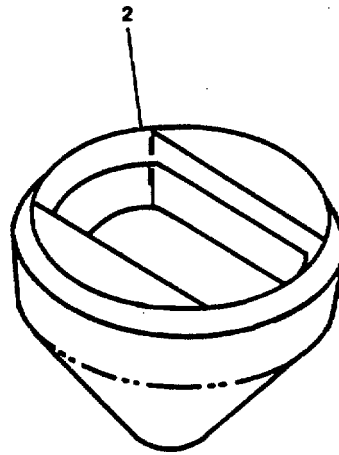
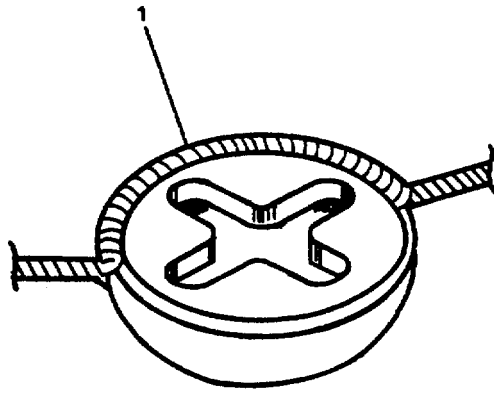

FIGURE 3-185. *Lashing Gear (Sockets).*

<b>MAINTENANCE OF WORKBOAT, LIFEBOATS/DAVITS</b>
--

**3-197. Replace/Repair Crane Assembly. (Figure 3-186)****This task covers:**

- |                    |                       |                  |
|--------------------|-----------------------|------------------|
| <b>a. Removal</b>  | <b>b. Disassembly</b> | <b>c. Repair</b> |
| <b>d. Assembly</b> | <b>e. Replacement</b> |                  |

**INITIAL SETUP:****Tools**

Tool kit, general mechanic's,  
5180-00-699-5273  
Tool kit, electrician's,  
5180-00-391-1087

Torque wrench,  
Kit PN 3377216

**Equipment Condition**

Electrical power OFF and cable removed,  
para. 2-167 .

**Materials/Parts**

Warning tags:, Item 1, Appendix

**REMOVAL**

- Connect pierside crane to four shackles (22).
- Tag and disconnect electrical leads (16) from deck socket (15).
- Remove 12 hexagon bolts (13) and lockwashers (14) from mounting flange (12).
- Remove crane assembly.

**DISASSEMBLY**

- Remove remote control (11).
- Remove plain hexagon nut (1), plain washer:(2), end: hexagon capscrews (3).
- Remove hexagon capscrew (5) and lockwasher (4).
- Remove gear guard (6).
- Remove hexagon capscrews (20) and lockwasher (21).
- Remove gear guard (19).
- Remove hexagon capscrews (8) and plain washer (7).

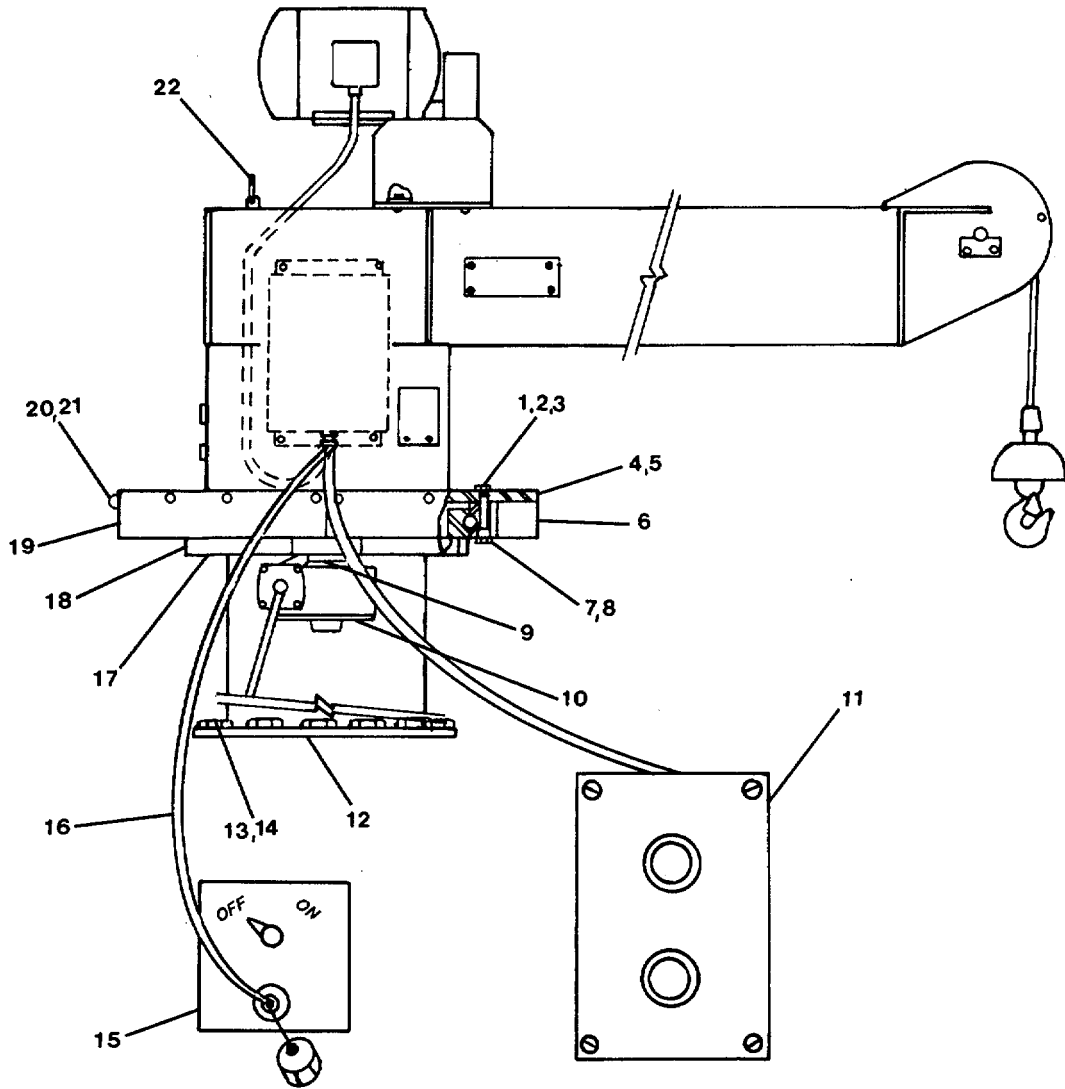

FIGURE 3-186. *Replace/Repair Crane Assembly.*

- h. Remove pipe plug (17).
- i. Remove base (18).
- j. Remove hexagon capscrew (9).
- k. Remove swing drive (10).

### **REPAIR**

Repair at this level of maintenance is by replacement of worn or defective parts.

### **ASSEMBLY**

- a. Install swing drive (10).
- b. Install hexagon capscrew (9).
- c. Install base (18).
- d. Install pipe plug (17).
- e. Install plain washer (7) and hexagon head capscrew (8).
- f. Install gear guard (19).
- g. Install lockwasher (21) and hexagon cap screw: (20).
- h. install gear guard (6).
- i. Install lockwasher (4) and hexagon capscrew (5).
- j. Install hexagon capscrew (3), plain washer (2), and plain hexagon nut (1).
- k. Install remote control (11).

### **REPLACEMENT**

- a. Install crane assembly.
- b. Install hexagon bolts (13). lockwashers- (14) and torque to 135 ft-lb.
- c. Remove tag and connect electrical leads (16) to deck socket (15).
- d. Disconnect pierside crane.



---

**3-199. Replace/Repair Winch Assembly. (Figure 3-187)**

---

**This task covers:**

- |                    |                       |                  |
|--------------------|-----------------------|------------------|
| <b>a. Removal</b>  | <b>b. Disassembly</b> | <b>c. Repair</b> |
| <b>d. Assembly</b> | <b>e. Replacement</b> |                  |
- 

---

**INITIAL SETUP**

---

Tools

Tool kit, general mechanic's,  
5180-00-699-5273  
Tool kit, electrician's,  
5180-00-391-1087  
Torque wrench,  
Kit PN 3377216

Equipment Condition

Electrical power to winch assembly  
turned OFF and tagged "Out of  
Service - Do Not Operate.  
Rope cable assembly removed  
para. 2-218

Material/Parts

A/C motor (with brake) P/N YMD 5225  
Plain unit bearing P/N YMD-5222  
Winch repair kit P/N YMD-4888R

---



---

**REMOVAL**

---

- a. Disconnect power cable; refer to para 2-131 .
- b. Remove hexagon capscrews (9), lockwashers (10), and plain hexagon nuts (11) .
- c. Remove winch assembly from crane assembly.

---

**DISASSEMBLY**

---

- a. Remove hexagon capscrews (5), lockwashers (6), and plain washers (7).
- b. Loosen hexagon capscrews (13) and lockwashers (14).
- c. Lift drum (12) and remove plain unit bearing (8).
- d. Remove hexagon capscrews (16) and lockwashers (17) attaching coupling guard (15).
- e. Remove coupling (18).
- f. Remove key (4).
- g. Remove hexagon capscrews (2) and lockwashers (3).

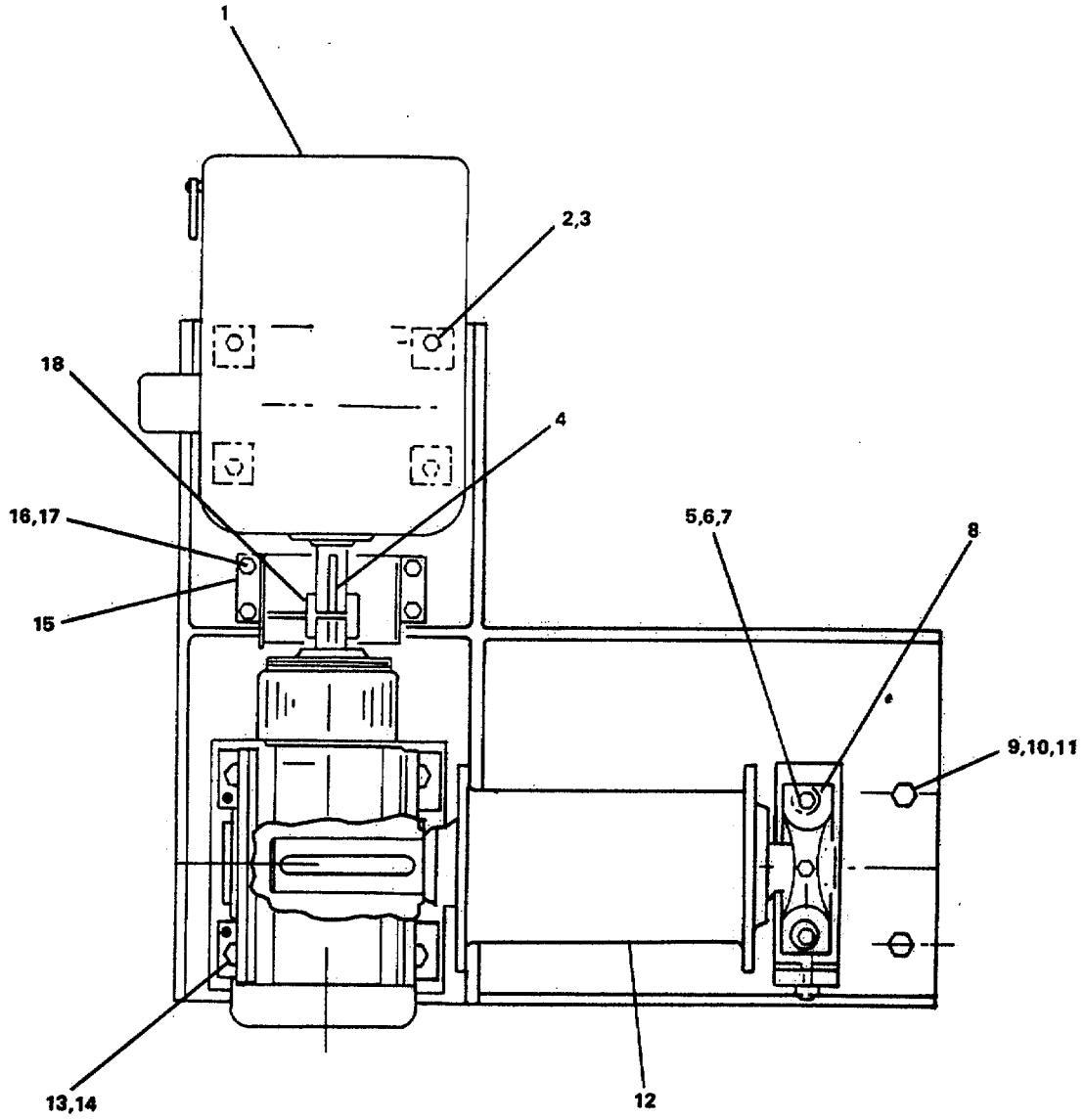

FIGURE 3-187. *Replace/Repair Winch.*

- h. Remove alternating motor (1).

## REPAIR

Repair at this level of maintenance is by replacement of plain unit bearing (8) and alternating motor (1).

## ASSEMBLY

- a. Install alternating motor (1) on winch assembly.
- b. Install lockwashers (3) and hexagon capscrews (2) and torque to 75 ft- lbs (102 N•m).
- c. Install key (4).
- d. Install coupling (18).
- e. Install coupling guard (15) and attach with hexagon capscrews (16) and lockwashers (17).
- f. Lift drum (12) and install plain unit bearing (8).
- g. Secure hexagon capscrews (13) on washers (14).
- h. Install plain washers (7), lockwashers (6), and hexagon capscrews (5).
- i. Grease plain unit bearing.

## REPLACEMENT

- a. Install winch assembly on crane assembly.
- b. Install capscrews (9), lockwashers (10), and plain hexagon nuts (11).
- c. Connect power cable; refer to para. 2-167.

**MOTOR CONTROL CENTERS/SWITCHBOARDS |**

---

**3-200. Replace/Repair Ship Service Switchboard.**

---

**This task covers:**

**a. Removal**

**b. Repair**

**c. Replacement**

---

**INITIAL SETUP:**

Tools

Tool kit, electrician's,  
E5180-00-391-1087  
Lifting fixture, P/N ST-125

Materials/Parts

Warning tag, Item 1, Appendix C

Equipment Condition

Power to ship service switchboard OFF,  
locked out, and tagged "Out of  
Service - Do Not Operate".  
All switchboard circuit breakers OFF.  
Circuit breakers, indicators, switches,  
meters, variable resistors, voltage  
regulators, rheostat, transformers,  
cartridge fuses, block fuseholders,  
relays and terminal boards removed  
as specified in paras. 2-291,  
paras. 2-292, 2-293, 2-294,  
2-295, 2-296, and 2-297.

---

**WARNING**

Electrocution, serious injury, or equipment damage can result from contact with live electrical circuits. Before beginning work on electrical systems, ensure electrical power is OFF, locked out and tagged to prevent turn on during maintenance.

**REMOVAL**

**NOTE**

The following procedure describes actions required to make ship service switchboard ready for removal from vessel.

- a. Disconnect and tag all wiring to ship service switchboard buses and terminal boards.
- b. Remove associated hardware from cable entrance plates and remove plates with attached electrical cables.
- c. Remove associated hardware holding switchboard to channel mounting base.

**Change 1 3-636**

- d. Install removable lifting eyes on top of ship service switchboard, if removed.
- e. Attach lifting fixture to lifting eyes.

## REPAIR

Repair is by replacement of ship service switchboard.

## REPLACEMENT

### NOTE

The following procedure describes actions required to complete installation of ship service switchboard once the switchboard has been placed into position in vessel.

- a. Remove lifting fixture from lifting eyes.
- b. Install associated hardware to secure switchboard to channel mounting base.
- c. Install cable entrance plates with attached electrical cables with associated hardware.
- d. Connect all electrical wiring to buses and terminal boards. Remove tags.
- e. Install all removed component parts as specified in paragraphs 2-291 through 2-297 .
- f. Turn on power to ship service switchboard and remove tags.
- g. Set circuit breakers, switches, rheostats, voltage regulators, and variable resistors to their required positions and observe meters and indicators.

**3-201. Replace/Repair Emergency Generator Switchboard.**

**This task covers:**

**a. Removal**

**b. Repair**

**c. Replacement**

**INITIAL SETUP:**

Tools

Tool kit, electrician's,  
5180-00-391-1087  
Lifting fixture, P/N ST-125

Materials/Parts

Warning tag, Item 1, Appendix C

Equipment Condition

Power to emergency generator switchboard OFF, locked out, and tagged "Out of Service - Do Not Operate".  
All switchboard circuit breakers OFF.  
Circuit breakers, indicators, switches, meters, rheostat, transformers, cartridge fuses, block fuseholders, relays and terminal boards removed as specified in paras. 2-291, 2-292, 2-293, 2-294, 2-295, 2-296, 2-297, 2-301, and 2-304.

**WARNING**

Electrocution, serious injury, or equipment damage can result from contact with live electrical circuits. Before beginning work on electrical systems, ensure electrical power is OFF, locked out and tagged to prevent turn on during maintenance.

**REMOVAL**

**NOTE**

The following procedure describes actions required to make emergency generator switchboard ready for removal from vessel.

- a. Disconnect and tag all wiring to emergency generator switchboard buses and terminal boards.

- b. Remove associated hardware from cable entrance plates and remove plates with attached electrical cables.
- c. Remove associated hardware holding switchboard to channel mounting base.
- d. Install removable lifting eyes on top of emergency generator switchboard, if removed.
- e. Attach lifting fixture to lifting eyes.

## REPAIR

Repair is by replacement of emergency generator switchboard.

## REPLACEMENT

### NOTE

The following procedure describes actions required to complete installation of emergency generator switchboard once the switchboard has been placed into position in vessel.

- a. Remove lifting fixture from lifting eyes.
- b. Install associated hardware to secure switchboard to channel mounting base.
- c. Install cable entrance plates with attached electrical cables with associated hardware.
- d. Connect all electrical wiring to buses and terminal boards. Remove tags.
- e. Install all removed component parts as specified in paragraphs 2-291 through 2-297, 2-301 and 2-304 .
- f. Turn on power to emergency generator switchboard and remove tags.
- g. Set circuit breakers, switches, and rheostats to their required positions and observe meters and indicators.

## MAINTENANCE OF PROPELLER SHAFT ASSEMBLY

---

### 3-202. Repair Propeller Shaft Assembly.

---

This task covers:

a. Removal

b. Repair

c. Replacement

---

#### INITIAL SETUP:

##### Tools

Tool kit, general mechanic's,  
5180-00-699-5273  
Torque wrench kit P/N 3377216

##### Materials/Parts

Gasket P/N D4-0138-0604  
Packing material P/N 44-1345-8060  
Lock wire P/N 43-0922-0040  
Loctite kit, Item 12, Appendix C  
Silicone grease, Item 11, Appendix C

##### Equipment Condition

Main engine stopped with propulsion control in NEUTRAL. Refer to TM 55-1905-223-10.  
Propulsion control on wheelhouse and engine control station consoles tagged "Out of Service - Do Not Operate."  
Vessel in shipyard dry dock facility

#### **NOTE**

With propulsion control in NEUTRAL, shaft will be locked by shaft expander tube brake.

---

#### **DISASSEMBLY (Figure 3-188)**

a. Remove packing material.

- (1) Secure S.W.-12 (isolation valve to port stern tube) or S.W.-13 (isolation valve to starboard stern tube) as appropriate.
- (2) Remove eight packing gland nuts (8) securing packing gland (9) to stuffing box assembly (4).
- (3) Pull packing gland (9) out of stern tube, sliding towards the reduction gear.
- (4) Using a packing puller, remove all but last ring of packing material (5). There is approximately 19 total rings



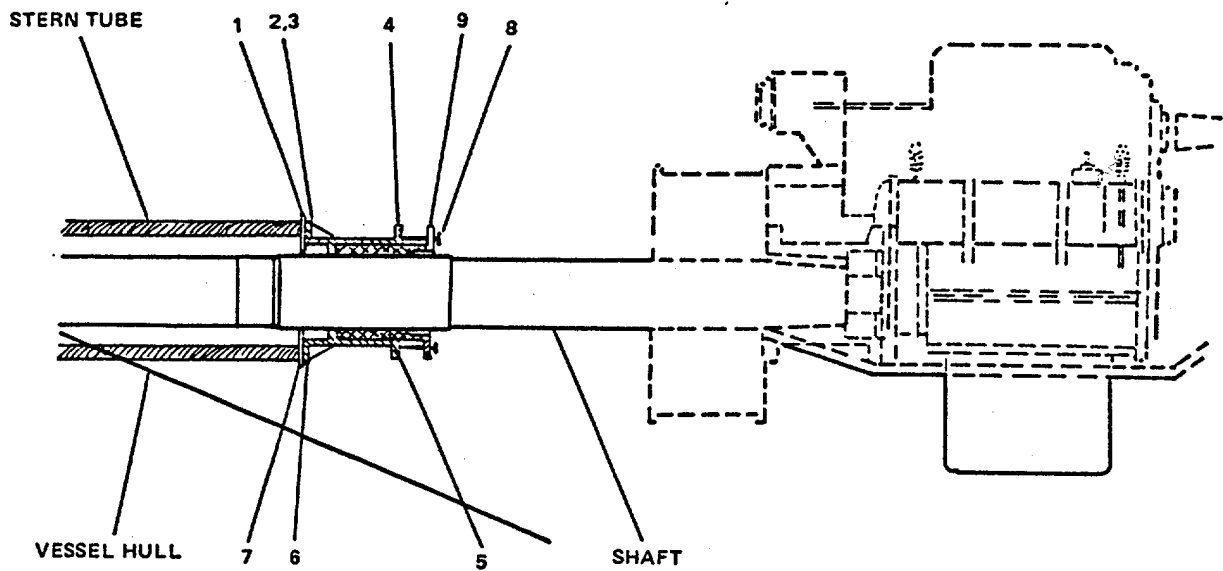

FIGURE 3-188. Repair Propeller Shaft Assembly.

b. Remove gasket.

- (1) Remove lock wire (1) from eight hex head capscrews (2) securing stern tube plate (7) to stern tube.
- (2) Remove eight hex head capscrews (2) and split-wing lockwashers (3).
- (3) Slide plate (7) forward toward engine along shaft far enough to gain access to aft portion of stuffing box assembly (4).
- (4) Remove gasket (6) from around stern tube.

**REPAIR**

Repair consists of replacing gasket (6) and packing material (5).

**ASSEMBLY**

- a. Replace gasket.

- (1) Adhesive splice new gasket (6). Replacement gasket (6) must be cut to fit around shaft and between stern tube and stern tube end plate (7) using Loctite, Catalog No. 0112, as follows:

**WARNING**

Clean-up solvent contains dimethyl formamide and is considered toxic. This solvent is provided with the Adhesive Kit for clean-up and is not essential to the splicing procedure. Using clean-up solvent, application should be used sparingly and limited to areas of the vessel having exhaust ventilation (such as under an exhaust hood). Use eye protection and rubber gloves. In case of skin contact, wash with soap and water. In case of eye contact, flush with water and seek medical attention as soon as possible.

- (2) Splicing. Clean razor blade with clean-up solvent, soap and water, or available degreasing solvent before each cut. Most razor blades are coated with a film of silicone oil to prevent rusting, which will interfere with good bonding of the spliced joint.

**CAUTION**

Ensure that the gasket being used is of the correctly sized cross section for the groove it will fit (check part number). Always use a sharp razor blade since excessive pressure during cutting will distort the rubber. Do not touch cut ends. Prevent contamination from dirt and oil during handling.

- (3) With gasket lying on a clean flat surface (Figure 3-189), use one slicing motion to cut the gasket to avoid jagged edges. Make the cut vertically, approximately on the radius, to form an "O" section.

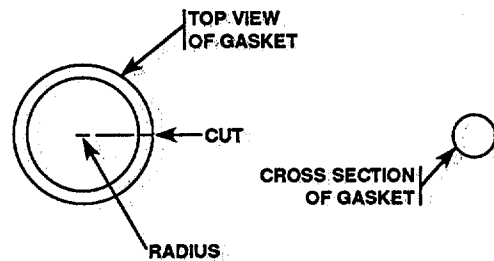

FIGURE 3-189. Cutting New Gasket.

**WARNING**

The adhesive is a cyanoacrylate type which is an eye irritant. In case of accident, flush with water only and seek medical attention as soon as possible. The adhesive bonds quickly and strongly on contact. In case of skin bonding, carefully peel or cut apart contacted areas. Do not pull apart as adhesive is stronger than skin and will tear skin off. Bond may be softened by soaking in nail polish remover or acetone.

- (4) Make the splice by applying a small drop of adhesive to one end of the cut gasket. If excess is applied, strike gasket on hard surface to shake off excess.
- (5) Immediately place gasket around shaft in groove on stern tube and plate and push ends of gasket together evenly in groove and maintain firm pressure on ends at joint for 10-30 seconds.
- (6) After 30 second cure, remove adhesive residue from end plate surface and gasket surface by wiping with clean, dry rag or scraping with a smooth plastic or brass tool, using care not to cut or scuff gasket surface.

**NOTE**

Do not use clean-up solvent to clean gasket. Allow adhesive to cure 1 hour minimum at room temperature before flexing or stretching.

- (7) After curing time of 1 hour, flex the bonded gasket joint and examine joint for lack of bond. Do not proceed with replacement if joint shows lack of bond.
- (8) Waterproof the bonded joint with a coating of Loctite waterproofing solution over the bond line. Apply just enough solution to cover the bond line completely and prevent air bubbles from forming in the coating, which will cause the coating to be porous.
- (9) Allow waterproofing solution to cure for 10 minutes. If still tacky, applying a coating of silicone grease in step (10) will ensure satisfactory installation.
- (10) Inspect new gasket (6, Figure 3-188) in groove on plate (7) to ensure it fits groove. Apply coating of silicone grease to new gasket (6).
- (11) Slide stuffing box assembly (4) and stern tube and plate (7) along shaft and against stern tube.
- (12) Install eight split-ring lockwashers (3) and hex head capscrews (2) to secure end plate (7) and stuffing box assembly (4) to stern tube. Tighten hex head capscrews to 350 ft-lb torque.
- (13) Install new lock wire (1) into hexhead capscrews (2) and secure.

b. Replace packing material.

- (1) Butt cut new 1-inch square waxed flat packing material in individual rings to exact length of shaft circumference.
- (2) Install new rings with butt and joints staggered in the upper half of the stuffing box around the shaft using packing gland (9) to push packing rings into stern tube. Ensure same number of rings are installed as was removed in step a(4), approximately 18 rings.
- (3) Install eight packing gland nuts (8) to secure packing gland (9) to stuffing box assembly (4).
- (4) Open appropriate seawater cooling valve, S.W.-12 (isolation valve to port stern tube) or S.W.-13 (isolation valve to starboard stern tube).
- (5) Operate main engine. Refer to TM 55-1905-223-10.
- (6) Adjust packing gland (9) until stern tube is cool to the touch and leakage is approximately 10 drops/minute.
- (7) Observe stern tube and plate (7) connection for leakage. If any leakage is present, gasket splice was not effective. Replace gasket.
- (8) Remove "Out of Service - Do Not Operate" tags.

**3-203. Replace Expander Tube Brake. (Figure 3-190)**

**This task covers:**

**a. Removal**

**b. Replacement**

**INITIAL SETUP:**

Tools

Tool kit, general mechanic's,  
5180-00-699-5273  
Lifting sling P/N 3375958  
Torque wrench kit P/N 3377216

Equipment Condition

Vessel in shipyard dry dock facility  
and propulsion shaft removed.

General Safety Instruction

Materials/Parts

Expander tube brake P/N 16VC 1000

**CAUTION**

The use of a lifting sling will be required to prevent injury to personnel and damage to equipment because of the weight (556 pounds) of the expander tube brake.

**REMOVAL**

**CAUTION**

Using a lifting sling to expander tube brake will prevent injury to personnel and damage to equipment.

- a. Attach lifting sling to expander tube brake (12) to support brake during removal. Weight of brake assembly exceeds 556 pounds.
- b. Remove four bolts and nuts (6) securing brake element support bracket (4) to mounting support brackets (7) welded to gear box (9) and engine foundation rail (8).
- c. Remove four dowels (1).
- d. Remove brake element support brackets (4).
- e. Remove twelve bolts (11) securing brake drum (2) to propeller shaft flange (10).
- f. Using lifting sling, lift brake (12) straight up, taking care not to damage propeller shaft flange (10).

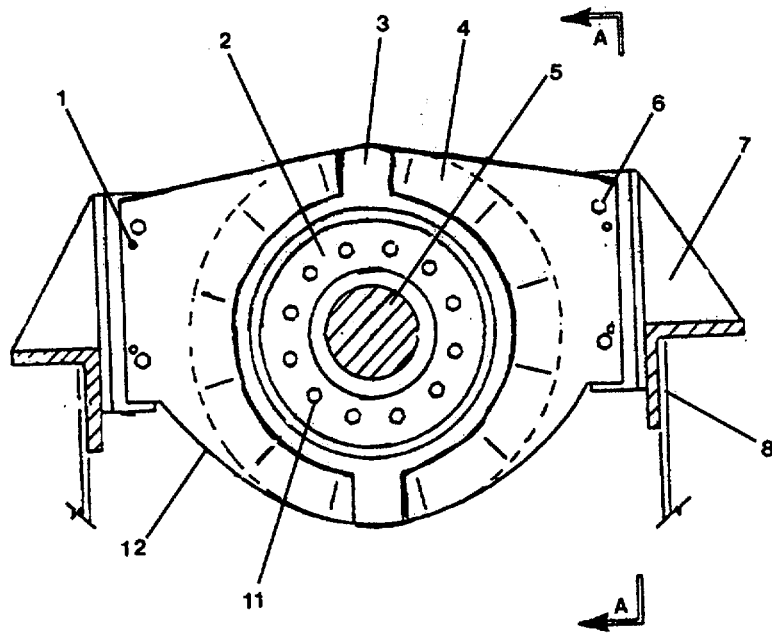

VIEW  
LOOKING FORWARD

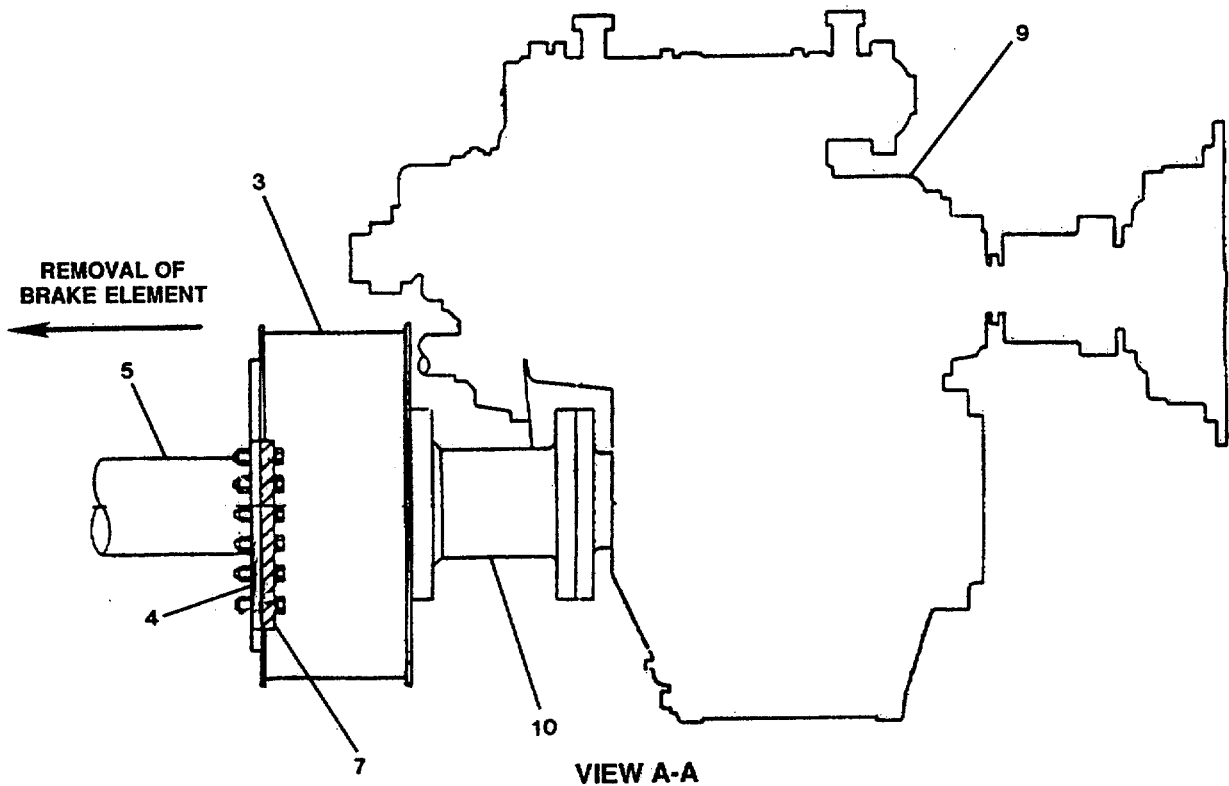

VIEW A-A

FIGURE 3-190. Expander Tube Brake.

## REPLACEMENT

### CAUTION

Using a lifting sling to expander tube brake will prevent injury to personnel and damage to equipment.

- a. Attach lifting sling to replacement expander tube brake (12) and support brake while installing. Brake weighs in excess of 556 pounds.
- b. Raise brake assembly (12) and position exactly above mounting support brackets (7) on engine/gearbox mounting foundation rails (8). Lower brake assembly down to match up with mounting holes on propeller shaft flange (10).
- c. Install twelve mounting bolts (11) and secure brake drum (2) and brake element (3) to propeller shaft flange (10).
- d. Install brake element support brackets (4) and four dowels (1).
- e. Install four bolts (6) and nuts and secure brake element support brackets (4) to mounting support brackets (7). Tighten bolts to 600 ft-lbs torque.
- f. Remove lifting sling.





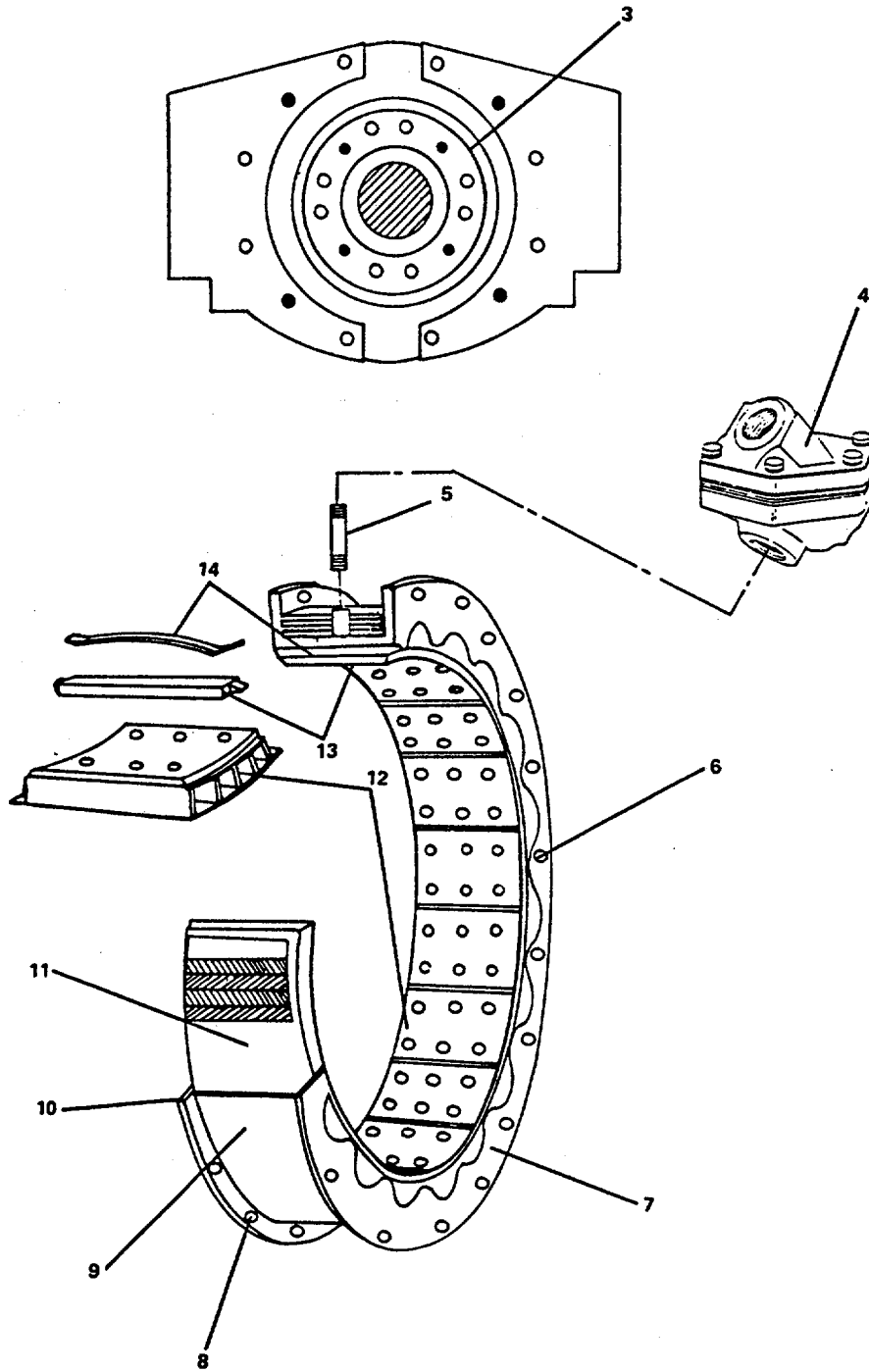

FIGURE 3-191. Expander Tube Brake Drum.

- (2) Remove capscrews (6 and 8), with washers and remove side plate (7) from brake element.
- b. Remove friction shoe assemblies.
- (1) Mark each friction shoe assembly (12) backing plate and its position on brake element rim (9) to ensure assembly in same position.
  - (2) Remove each friction shoe assembly (12) from brake element rim (9). The torque bar (13) and flat release spring (14) will come out with the friction shoe assembly as a unit.
  - (3) Using a block of wood, knock each torque bar (13) and flat release spring (14) from friction shoe assembly.

c. Remove rubber actuating tube.

- (1) Disconnect air tubing from IN port of quick exhaust safety release valve (4).
- (2) Remove quick exhaust safety release valve (4) from straight adapter (5).
- (3) Remove straight adapter (5) from rubber actuating tube valve (1), Figure 3-192 .

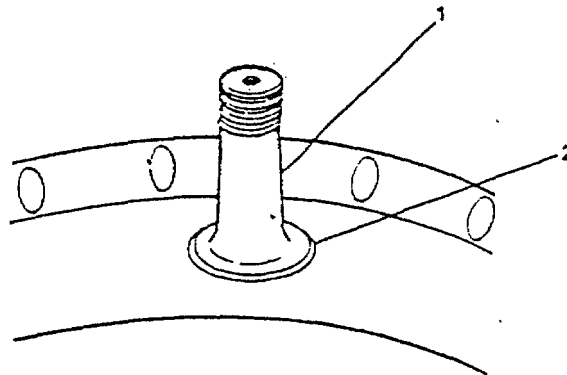

FIGURE 3-192. *Rubber Actuating Tube.*

- (4) Remove snap ring (2) securing rubber actuating tube valve (1) to the rim. Replacement snap ring is furnished with replacement tube.
- (5) Using smooth bar, insert bar between rubber actuating tube (11, Figure 3-191) and rim (9) and force actuating tube valve (1, Figure 3-192) to clear hole in rim and pull tube out of rim.

## REPAIR

a. Inspect friction shoe assembly.

- (1) Inspect each friction shoe assembly (12, Figure 3-191) for broken or cracked flat release springs (14) and torque bars (13). Replace defective springs and torque bars with new ones.

**CAUTION**

The eight friction shoe assemblies must be replaced as a set.  
Do not replace individual friction shoe assemblies.

- (2) Inspect friction shoe assembly (12) for wear, heat distortion or glazed condition. If any single assembly is distorted or worn more than 1/3 its original size (compare with new one), replace all eight friction shoe assemblies.
  - (3) Clean glazed friction shoe assembly (12) linings by roughing up surface with medium grit sandpaper.
- b. Inspect rubber actuating tube (11) for cracks, swellings, hardness or ply separation. Replace defective tube with new one.
  - c. Inspect quick release exhaust safety valve (4) for damaged port threads damaged, replace with new one.
  - d. Inspect brake drum (3) surface for grooved or worn surface spots. If found to be grooved or have worn spots, drum must be replaced after shaft removal, which will require shipyard dry dock facility maintenance.

**ASSEMBLY**

- a. Install rubber actuating tube.

**NOTE**

Original rubber actuating tube is manufactured in one continuous circle. Replacement butt end tubes, P/N 412594, are divided in half with each end sealed to facilitate installation.

- (1) Install replacement rubber actuating butt end tube (11) in brake element center rim (9), positioning tube air valve (1, Figure 3-192) up through rim opening.
  - (2) Install snap ring (2) on air valve (1).
  - (3) Install straight adapter (5, Figure 3-191) on actuator tube air valve (1, Figure 3-192).
  - (4) Install quick release exhaust valve (4, Figure 3-191) OUT port onto straight adapter (5).
  - (5) Connect air tubing to quick release exhaust valve (4) IN port.
- b. Install friction shoe assembly.
    - (1) Using a block of wood, drive torque bar (13) and flat release spring (14) into friction shoe assembly (12).

- (2) Install friction shoe assembly (12) onto rim (9) as marked during DISASSEMBLY.
- c. Install brake element side plate.
- (1) Install side plate (7) on center rim (9) as marked during DISASSEMBLY, ensuring dowel portion of torque bar (13) is seated in side plate (7) hole.
  - (2) Install capscrews (6 and 8) with washers (6) and secure side plate (7).
- d. Remove "Out of Service - Do Not Operate" tags.

---

**3-205. Replace/Repair Electrical Self Generating (Shaft) Tachometer. (Figure 3-193)**

---

**This task covers:**

**a. Removal**

**b. Repair**

**c. Replacement.**

---

**INITIAL SETUP:**

Tools

Tool kit, general mechanic's,  
5180-00-699-5273  
Fuse puller, 5120-00-224-9453

Materials/Parts

Electrical self generating (shaft)  
tachometer P/N DST 2000  
Terminal board P/N DST 257

Equipment Condition

Main engine shut down. Refer to  
TM 55-1905-223-10.  
Control and starting air valves to main  
engine closed (TM 55-1905-223-24-18)  
and tagged "Out of Service - Do  
Not Operate."

---

**REMOVAL**

- a. Motional transducer removed. Refer to paragraph 2-307 .
- b. Dimmer rheostats removed. Refer to paragraph 2-307 .
- c. Arbitrary scale meters for wheelhouse and engine control station consoles removed. Refer to paragraph 2-307 .

**WARNING**

ENGINE RM DC PNL EP024 contains 24 VDC. To prevent serious injury or damage to equipment, fuse pullers must be used to remove fuse cartridges.

- d. On ENGINE RM DC PNL EP024, use fuse puller and remove fuse cartridge #13, SFT TACH (STBD) or #14, SFT TACH (PORT) to remove 24 Vdc supply to shaft tachometer circuit.
- e. On steel box enclosure (1), release fastener (7) and open cover (6).
- f. Tag and disconnect cable (5) leads from terminals #16 and #17 on terminal board (3). Tag and disconnect ground shield on cable (5) from terminal #8 on terminal board (3).
- g. Disassemble cable (5) stuffing tube and remove cable (5) and stuffing tube from steel box enclosure (1).

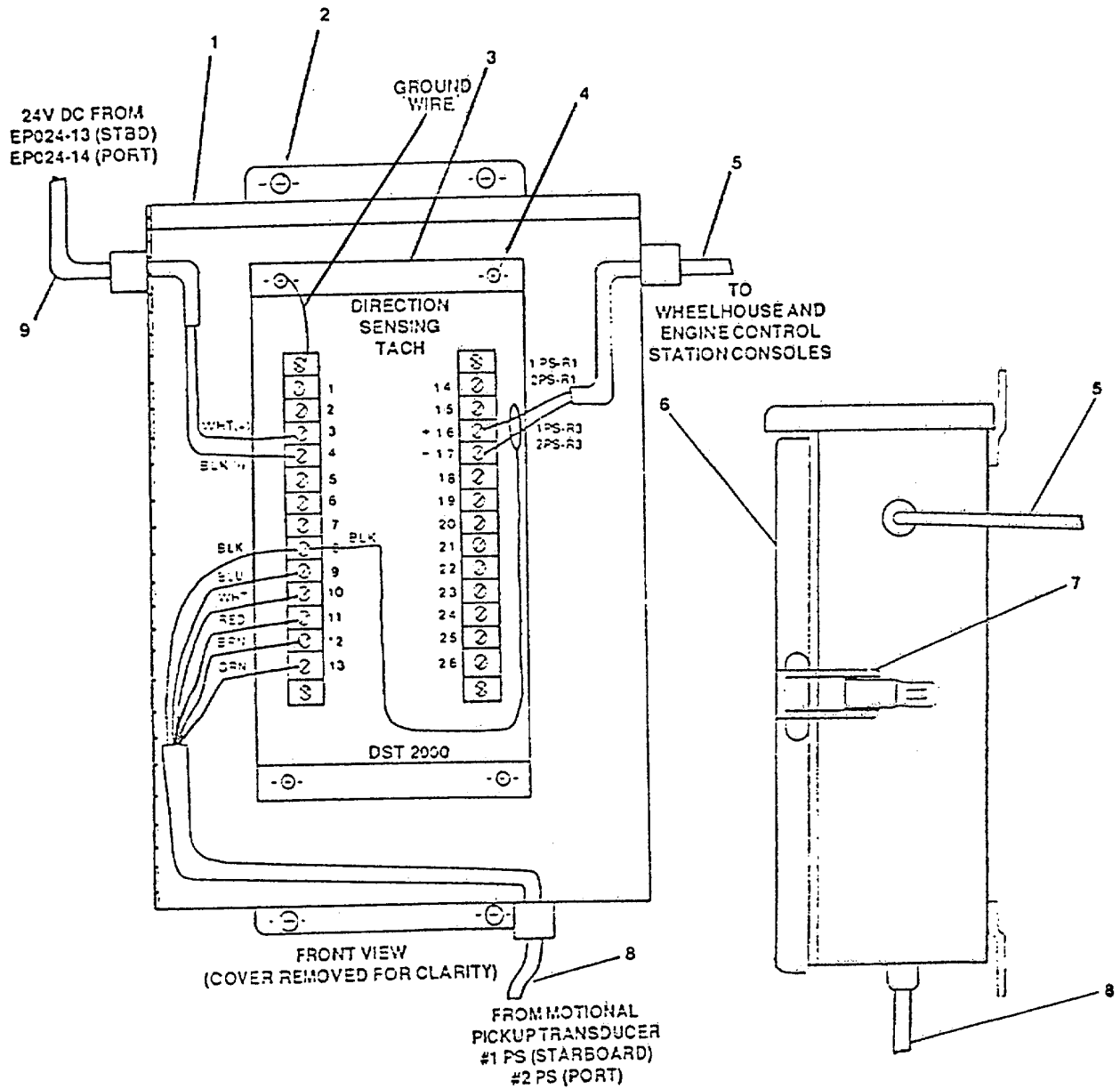

FIGURE 3-193. Electrical Self Generating (Shaft) Tachometer.

- h. Tag and disconnect cable (8) leads from terminals #8, 9, 10, 11, 12 and 13 on terminal board (3).
- i. Disassemble cable (8) stuffing tube and remove cable (8) and stuffing tube from steel box enclosure (1).
- j. Tag and disconnect cable (9) leads from terminals #3 and #4 on terminal board (3).
- k. Disassemble cable (9) stuffing tube and remove cable (9) and stuffing tube from steel box enclosure (1).
- l. Support steel box enclosure (1) and remove mounting screws (2) and steel box enclosure (1).
- m. Remove mounting screws (4) and remove terminal board (3) from steel box enclosure (1).

## REPAIR

Repair of the electrical self generating (shaft) tachometer is by replacement of terminal board (3).

## REPLACEMENT

- a. Install terminal board (3) in steel box enclosure (1) and secure with mounting screws (4).
- b. Support steel box enclosure (1) and align mounting holes and secure with screws (2).
- c. Route cable (9) with stuffing tube into knockout hole in steel enclosure box (1).
- d. Connect cable (9) leads to terminals #4 and #3. Remove tags.
- e. Assemble stuffing tube on cable (5) and secure to steel box enclosure (1).
- f. Route cable (8) with stuffing tube into knockout hole on steel box enclosure (1).
- g. Connect cable (8) leads to terminals #8, 9, 10, 11, 12 and 13. Remove tags.
- h. Assemble cable (8) stuffing tube and secure to steel box enclosure (1).
- i. Route cable (5) with stuffing tube into knockout hole in steel box enclosure (1).
- j. Connect cable (5) leads to terminals #16 and #17 and ground shield to terminal #8 on terminal board (3). Remove tags.
- k. Assemble cable (5) stuffing tube and secure to steel box enclosure (1).

- l. Close cover (6) and secure with fastener (7).
- m. Install arbitrary scale meters in wheelhouse and engine control station consoles. Refer to paragraph 2-307 .
- n. Install dimmer rheostats. Refer to paragraph 2-307 .
- o. Install motional pickup transducer. Refer to paragraph 2-307 .

**WARNING**

ENGINE RM DC PNL EP024 contains 24 Vdc. To prevent serious injury to personnel and damage to equipment, fuse puller must be used to install fuse cartridge.

- p. On ENGINE RM DC PNL EP024, use fuse puller and install fuse cartridge #13, SFT TACH (STBD) or #14, SFT TACH (PORT) to apply 24 Vdc supply to shaft tachometer circuit.



**MAINTENANCE OF VALVES/STRAINERS****3-206. Repair 2-1/2 Check Angle Valve. (Figure 3-194)****This task covers:****a. Disassembly****b. Repair****c. Assembly****INITIAL SETUP:**Tools

Tool kit, general mechanic's,  
5180-00-699-5273

Equipment Condition

Angle valve removed, para. 2-308 .

Materials/Parts

2-1/2 inch stop check angle  
valve P/N B-142-0000

**DISASSEMBLY**

- a. Remove wheelnut (1) and handwheel (2).
- b. Remove plain hexagon nut (14).
- c. Remove valve cap (4) and gasket (9).
- d. Remove gland nut (5), gland packing (6), gland stud (7), and packing material (8).
- e. Remove stem (3).
- f. Remove disc nut (10).
- g. Remove disc (11).
- h. Remove ring seat (12) from body (13).

**REPAIR**

Repair at this level of maintenance is by replacement of worn or defective parts.

**ASSEMBLY**

- a. Install ring seat (12) into body (13).

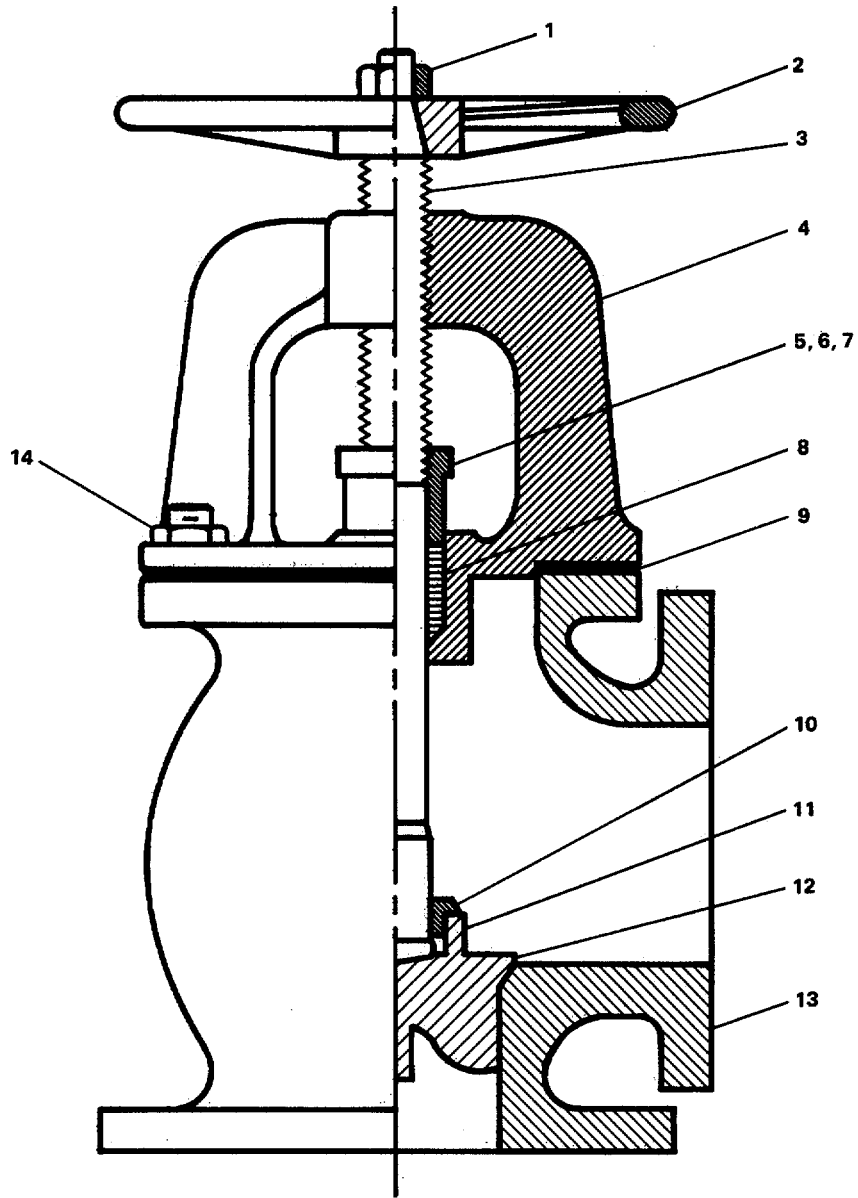

FIGURE 3-194. Stop Check Angle Valve. Repair.

- b. Install disc (11) and disc nut (10).
- c. Install stem (3).
- d. Install packing material (8).
- e. Install gland stud (7), gland packing (6), and gland nut (5).
- f. Install gasket (9).
- g. Install valve cap (4).
- h. Install plain hexagon nut (14).
- i. Install handwheel (2).
- j. Install wheelnut (1)
- k. Replace angle valve, paragraph 2-360 .

---

**3-207. Repair 4-Inch Three-Way Ball Valve. (Figure 3-195)**

---

**This task covers:****a. Disassembly****b. Repair****c. Assembly**

---

**INITIAL SETUP:****TOOLS**Tool kit, general mechanic's,  
5180-00-699-5273**Equipment Condition**

Ball valve removed, para. 2-309 .

**Materials/Parts**4 inch three-way ball valve  
P/N MP-20-86165

---

**DISASSEMBLY**

- a. Remove hexagon head capscrew (5) and lockwasher (6).
- b. Remove bracket (3) and handle (4).
- c. Remove packing retainer (26).
- d. Remove gland liner (27).
- e. Remove fluid valve stem (25).
- f. Remove packing retainer (24) and preformed packing (23).
- g. Remove screw (20) and lockwasher (19).
- h. Remove end fitting (21) and gasket (18) from body (30).
- i. Remove valve seat (22).
- j. Remove ball (15).
- k. Remove hexagon head capscrew (9) and lockwasher (10).
- l. Remove end fitting (11) and gasket (8).
- m. Remove valve seat (7).
- n. Remove hexagon head capscrew (13) and lockwasher (12).
- o. Remove end fitting (16) and gasket (17).

- p. Remove valve seat (14).
- q. Remove hexagon head capscrew (1) and lockwasher (2).
- r. Remove end fitting (28) and gasket (29).

## REPAIR

Repair at this level of maintenance is by replacement of worn or defective parts.

## ASSEMBLY

- a. Install gasket (29) and end fittings (28) on body (30).
- b. Install lockwasher (2) and hexagon head capscrew (1).
- c. Install valve seat (14).
- d. Install gasket (17) and end fitting (16).
- e. Install lockwasher (12) and hexagon head capscrew (13).
- f. Install valve seat (7).
- g. Install gasket (8) and end fitting (11).
- h. Install lockwasher (10) and hexagon head capscrew (9).
- i. Install ball (15).
- j. Install valve seat (22).
- k. Install gasket (18) and end fitting (21).
- l. Install lockwasher (19) and hexagon head capscrew (20).
- m. Install preformed packing (23) and packing retainer (24).
- n. Install fluid valve stem (25).
- o. Install gland liner (27).
- p. Install packing retainer (26).
- q. Install handle (4) and bracket (3).
- r. Install lockwasher (6) and hexagon head capscrew (5).
- s. Replace ball valve, paragraph 2-309 .

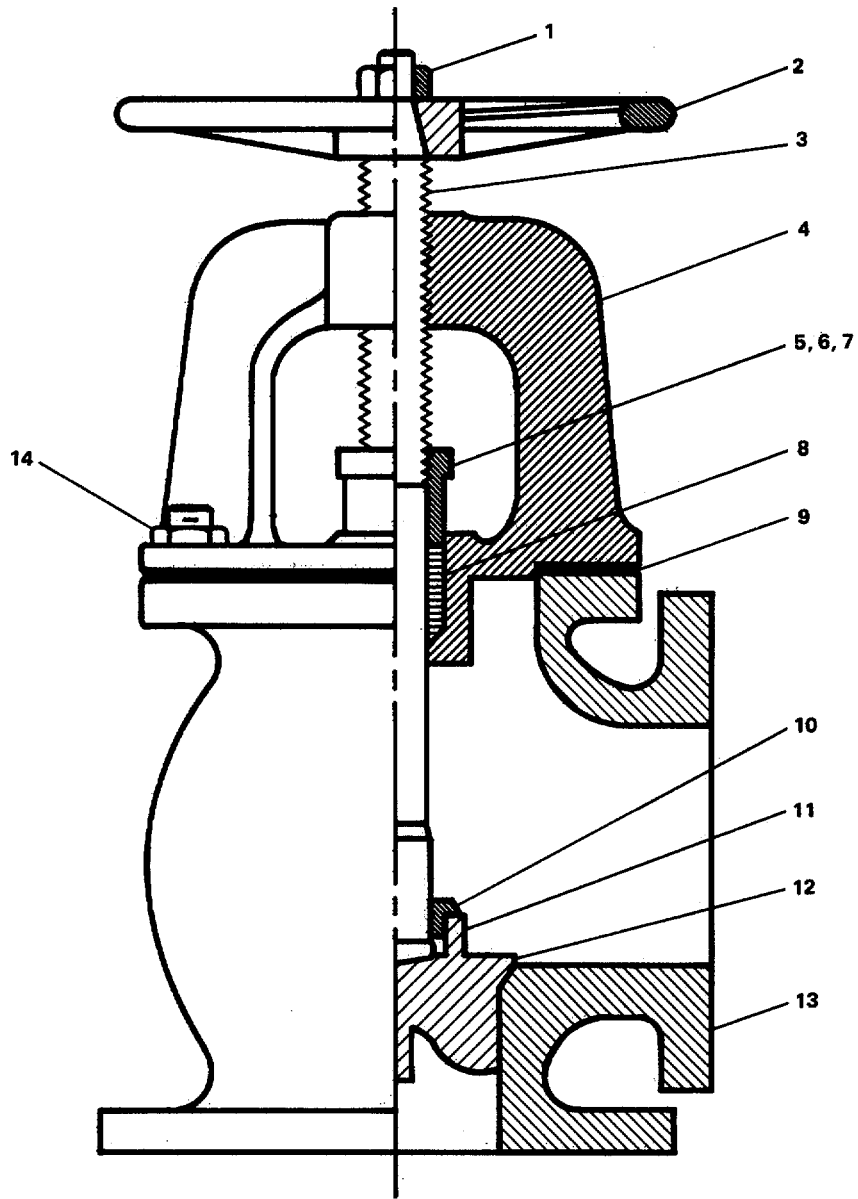

FIGURE 3-195. 4-Inch Three Way Ball Valve. Repair.

---

**3-208. Repair 4-Inch Three-Way Ball Valve. (Figure 3-196)**

---

**This task covers:****a. Disassembly****b. Repair****c. Assembly****INITIAL SETUP:**Tools

Tool kit, general mechanic's,  
5180-00-699-5273

Equipment Condition

Ball valve removed, para. 2-310 .

Materials/Parts

4-inch three-way ball valve  
P/N MP-20-F15 4IN

**DISASSEMBLY**

- a. Remove hexagon nut (28) and lockwasher (27).
- b. Remove handle (4).
- c. Remove packing retainer (25).
- d. Remove gland liner (26).
- e. Remove fluid stem valve (5).
- f. Remove packing retainer (24) and preformed packing (6).
- g. Remove hexagon head capscrew (21) and lockwasher (20).
- h. Remove end fitting (23) and gasket (19) from body (18).
- i. Remove valve seat (22).
- j. Remove ball (15).
- k. Remove hexagon head capscrew (8) and lockwashers (7).
- l. Remove side fitting (9) and gasket (11).
- m. Remove valve seat (10).
- n. Remove hexagon head capscrew (13) and lockwasher (12).
- o. Remove side fitting (16) and gasket (17).

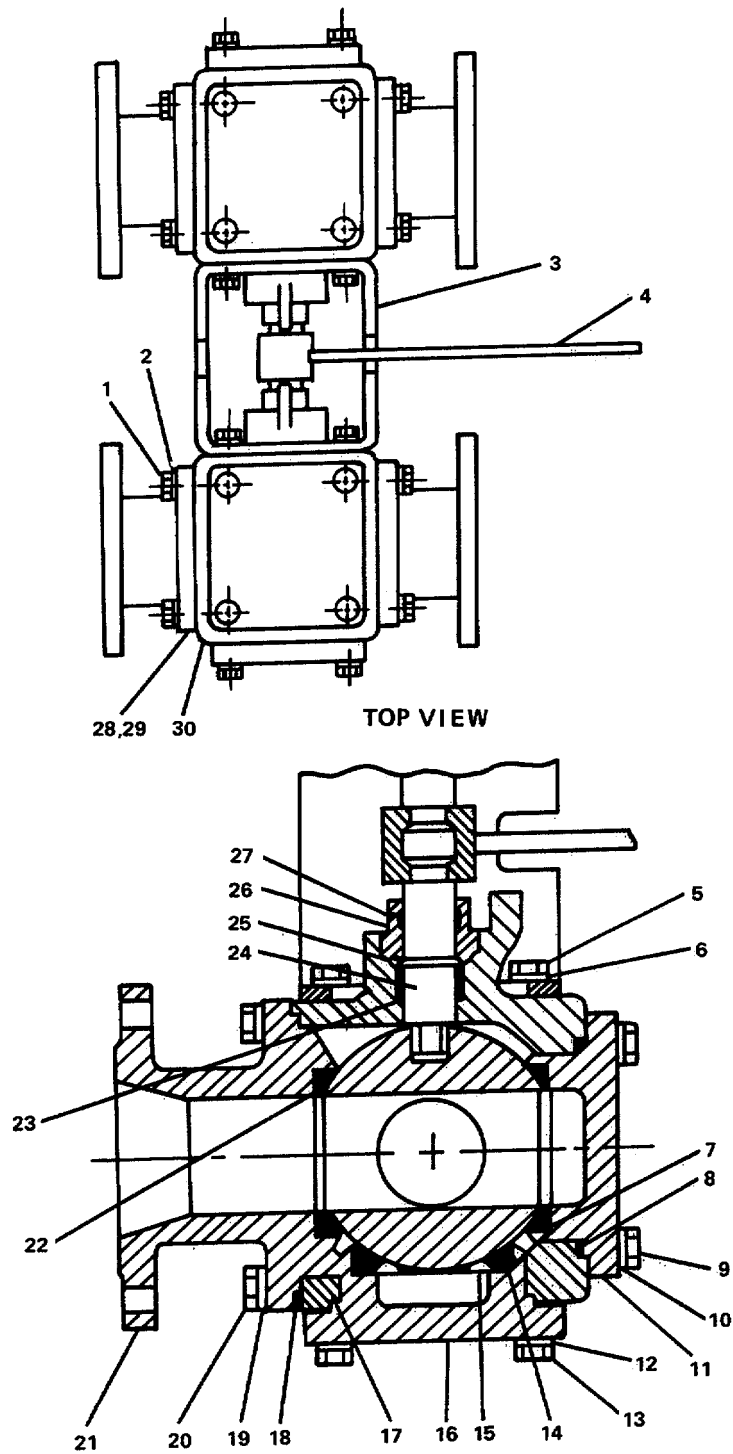

FIGURE 3-196. 4-Inch Three-Way Ball Valve. Repair.



- p. Remove valve seat (14).
- q. Remove hexagon head capscrew (1) and lockwasher (2).
- r. Remove side fitting (3).

## REPAIR

Repair at this level of maintenance is by replacement of worn or defective parts.

## ASSEMBLY

- a. Install side fitting (3).
- b. Install lockwasher (2) and hexagon head capscrew (1).
- c. Install valve seat (14).
- d. Install gasket (17) and side fitting (16).
- e. Install lockwasher (12) and hexagon head capscrew (13).
- f. Install valve seat (10).
- g. Install gasket (11) and side fitting (9).
- h. Install lockwasher (7) and hexagon head capscrew (8).
- i. Install ball (15).
- j. Install valve seat (22).
- k. Install gasket (19) and end fitting (23) on body (18).
- l. Install lockwasher (20) and hexagon head capscrew (21).
- m. Install performed packing (6) and packing retainer (24).
- n. Install fluid valve stem (5).
- o. Install gland liner (26).
- p. Install packing retainer (25).
- q. Install handle (4).
- r. Install lockwasher (27) and hexagon nut (28).
- s. Replace ball valve, paragraph 2-310 .

---

**3-209. Repair 4-Inch Swing Check Valve. (Figure 3-197)**

---

This task covers:           a. Disassembly,           b. Repair,   c. Assembly.

---

**INITIAL SETUP**Tools

Tool kit, general mechanic's,  
5180-00-699-5273

Equipment Condition

Swing check valve removed, para. 2-311 .

Materials/Parts

4-inch swing check valve  
P/N 65341F - 4IN

---

**DISASSEMBLY**

- a. Remove plain hexagon nut (5).
- b. Remove access cover (7).
- c. Remove gasket (6).
- d. Remove vent plug (8).
- e. Remove headed straight pin (3).
- f. Remove disk hanger (2).
- g. Remove cotter pin (9), plain cap nut (10) and flat washer (11).
- h. Remove valve disk (13).
- i. Remove retainer ring (12).
- J. Remove plain stud (4) from valve body (1).

**REPAIR**

Repair at this level of maintenance is by replacement of worn or defective parts.

**ASSEMBLY**

- a. Install plain stud (4) into valve body (1).

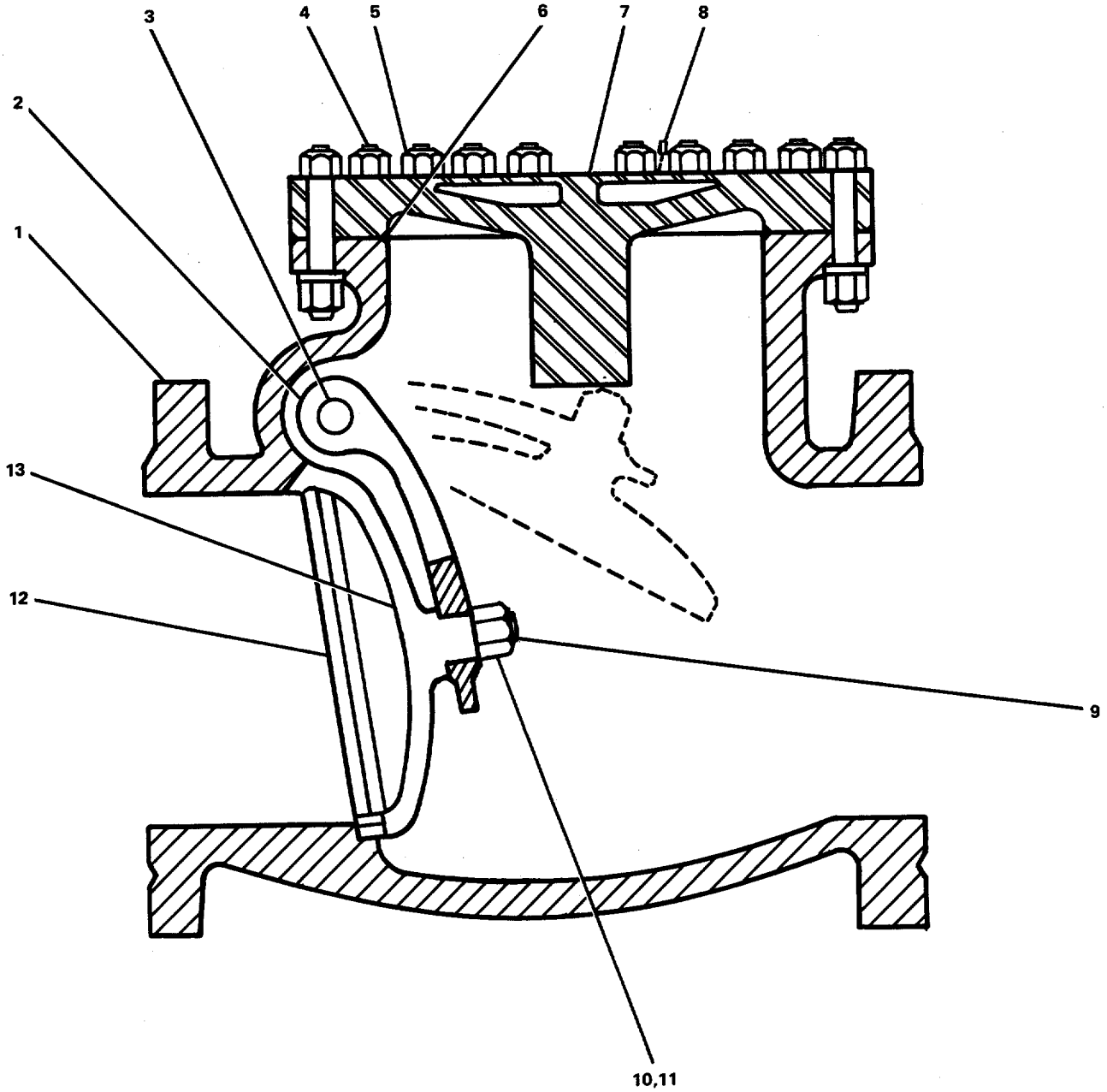

FIGURE 3-197. 4-Inch Swing Check Valve, Repair.

- b. Install retainer ring (12).
- c. Install valve disk (13).
- d. Install flat washer (11), plain cap nut (10) and cotter pin (9).
- e. Install disk hanger (2).
- f. Install headed straight pin (3).
- g. Install vent plug-(8).
- h. Install gasket (6).
- i. Install access cover (7).
- j. Install plain hexagon nut (5).
- k. Replace swing check valve, paragraph 2-311 .

**3-668**

---

**3-210. Repair 5-Inch Simplex Sediment Strainer. (Figure 3-198)**

---

**This task covers:**      **Repair.**

---

**INITIAL SETUP**Tools

Tool kit, general mechanic's,  
5180-00-699-5273

Equipment Condition

Sediment strainer removed, para. 2-312 .

Materials/Parts

5-inch simplex sediment  
strainer P/N ST0720500F6C

---

**REPAIR**

Repair at this level of maintenance is by replacement of pipe plug (2) and drain plug (3) in body (1). Replace sediment strainer, paragraph 2-365 .

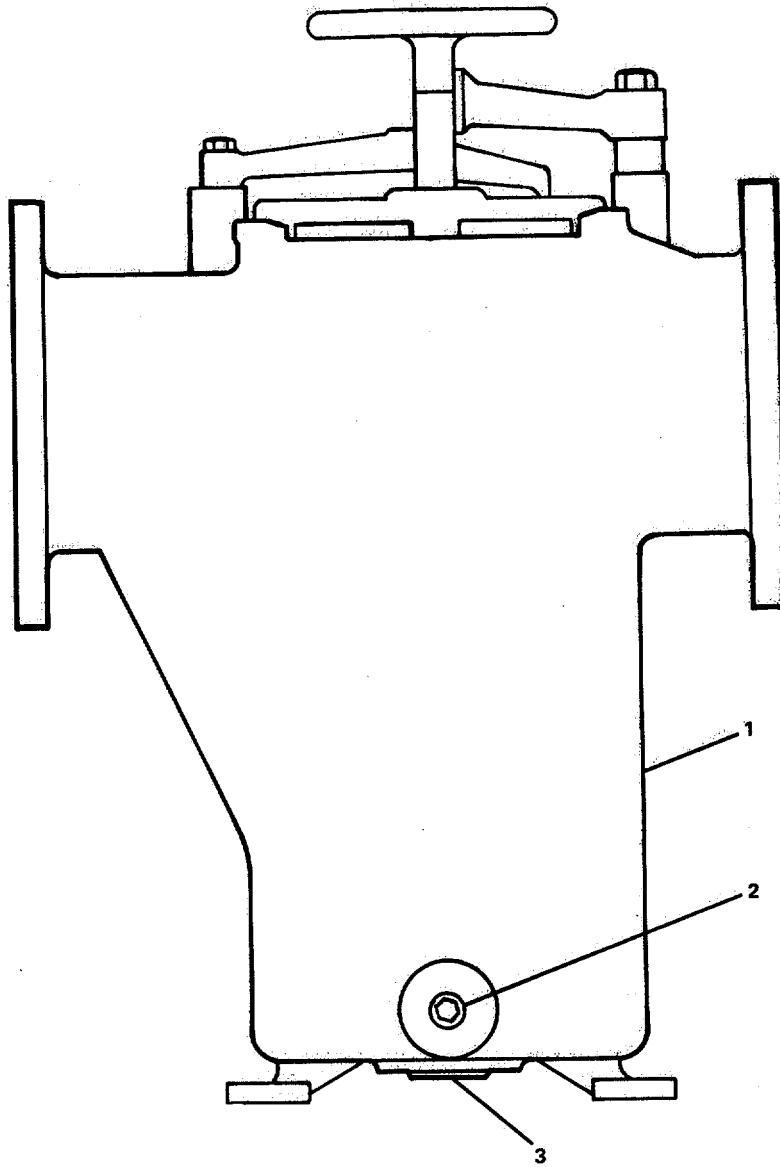

FIGURE 3-198. 5-Inch Simplex Sediment Strainer, Repair.

---

**3-211. Repair 8-Inch Simplex Sediment Strainer. (Figure 3-199)**

---

**This task covers:**      **Repair.**

---

**INITIAL SETUP**Tools

Tool kit, general mechanic's,  
5180-00-699-5273

Equipment Condition

Sediment strainer removed, para. 2-314 .

Materials/Parts

8-inch simplex sediment  
strainer P/N 683

---

**REPAIR**

Repair at this level of maintenance is by replacement of studs (1) in housing (2). Replace sediment strainer, paragraph 2-313 .

**3-671**

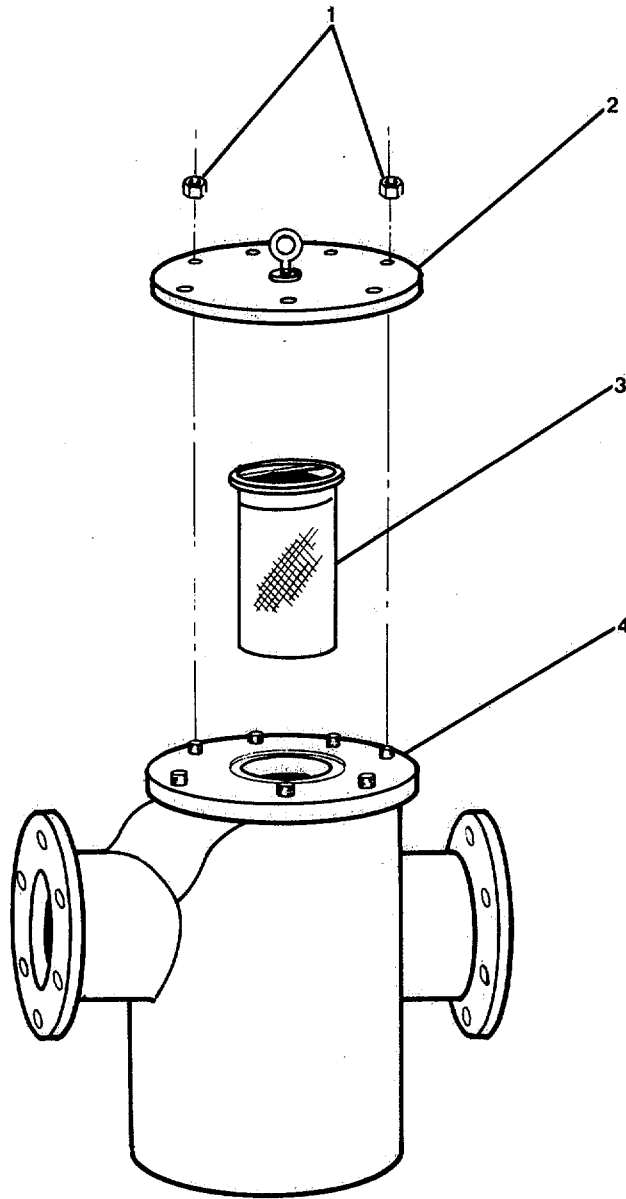

FIGURE 3-199. 8-Inch Simplex Sediment Strainer, Repair.



---

**3-212. Repair 4-Inch Sediment Strainer Basket. (Figure 3-200)**

---

**This task covers:**      **Repair.**

---

**INITIAL SETUP**Tools

Tool kit, general mechanic's,  
5180-00-699-5273

Equipment Condition

Sediment strainer basket removed,  
para. 2-314 .

Materials/Parts

4-inch sediment strainer basket  
P/N AN-4.0-185-E3

---

**REPAIR**

Repair at this level of maintenance is by replacement of stud (1) in body (2). Replace sediment strainer basket, paragraph 2-314 .

**3-673**

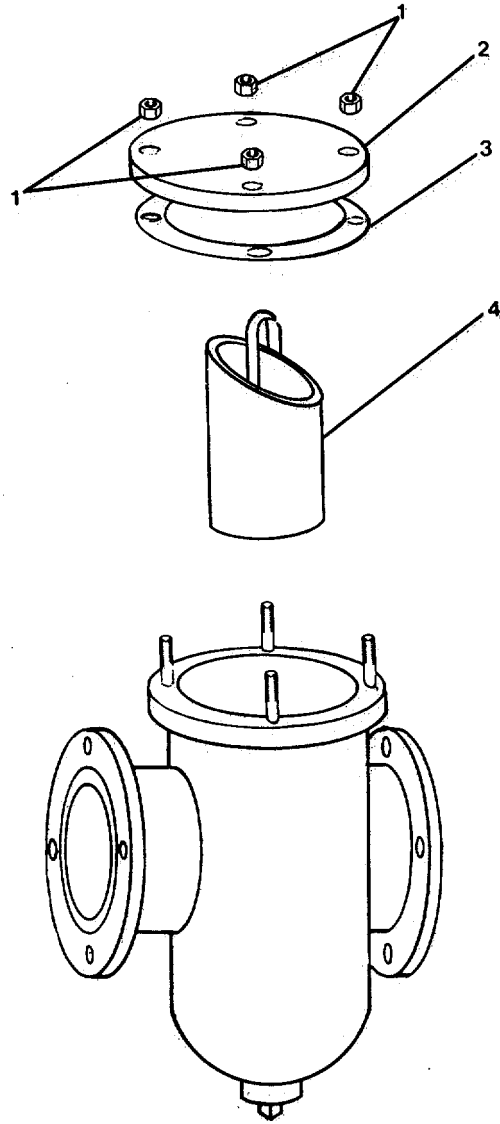

FIGURE 3-200. 4-Inch Sediment Strainer Basket, Repair.

---

**3-213. Repair 5-Inch Sediment Strainer Basket. (Figure 3-201)**

---

**This task covers:     Repair.**

---

**INITIAL SETUP**Tools

Tool kit, general mechanic's,  
5180-00-699-5273

Equipment Condition

Sediment strainer basket removed,  
para. 2-315 .

Materials/Parts

5-inch sediment strainer basket  
P/N AN-5.0-185-E3

---

**REPAIR**

Repair at this level of maintenance is by replacement of plain stud (1) in body (2). Replace sediment strainer basket, paragraph 2-315 .

**3-675**

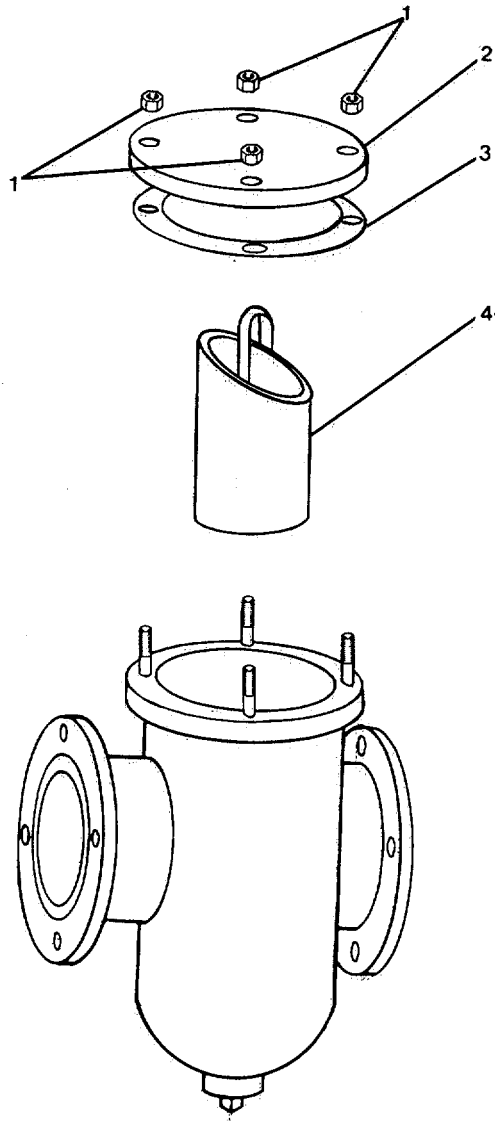

FIGURE 3-201. 5-Inch Sediment Strainer Basket, Repair.

---

**3-214. Repair 2-1/2-Inch Sediment Strainer Basket. (Figure 3-202)**

---

**This task covers:     Repair.**

---

**INITIAL SETUP**Tools

Tool kit, general mechanic's,  
5180-00-699-5273

Equipment Condition

Sediment strainer basket removed,  
para. 2-316 .

Materials/Parts

2-1/2-inch sediment strainer basket  
P/N AN-2.5-125F-B-C

---

**REPAIR**

Repair at this level of maintenance is by replacement of plain stud (1) in body (2). Replace sediment strainer basket, paragraph 2-316 .

**3-677**

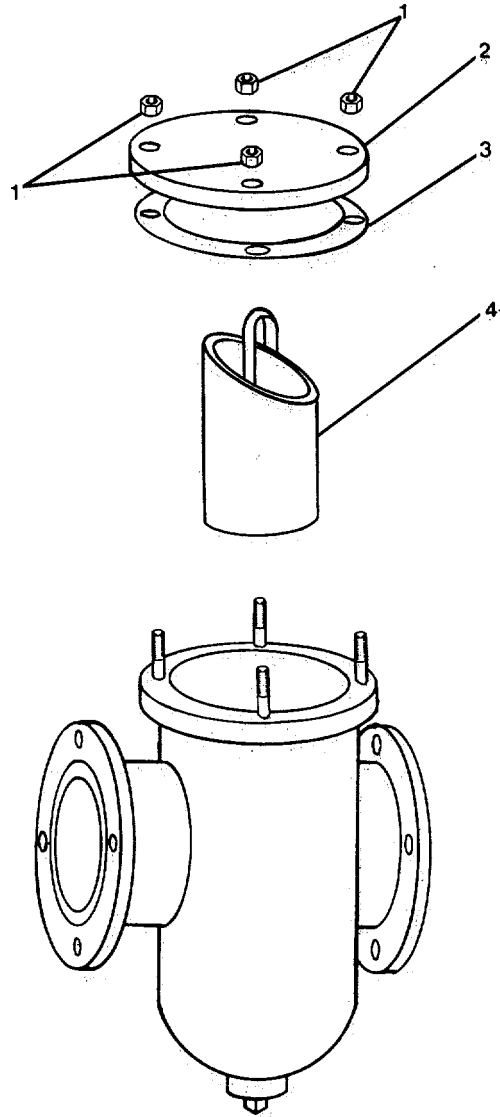

FIGURE 3-202. 2-1/2-Inch Sediment Strainer Basket, Repair.

---

**3-215. Repair 3-Inch Duplex Sediment Strainer. (Figure 3-203)**

---

**This task covers: Repair.**

---

**INITIAL SETUP**Tools

Tool kit, general mechanic's,  
5180-00-699-5273

Materials/Parts

Corrosion preventive anode (2)  
P/N ST510 ZINCANODE

Equipment Condition

Duplex sediment strainer removed,  
para. 2-317 .

Duplex sediment strainer disassembled,  
para. 2-317 .

---

**REPAIR**

Repair at this level of maintenance is by replacement of corrosion preventive zinc anode (1).

**3-679**

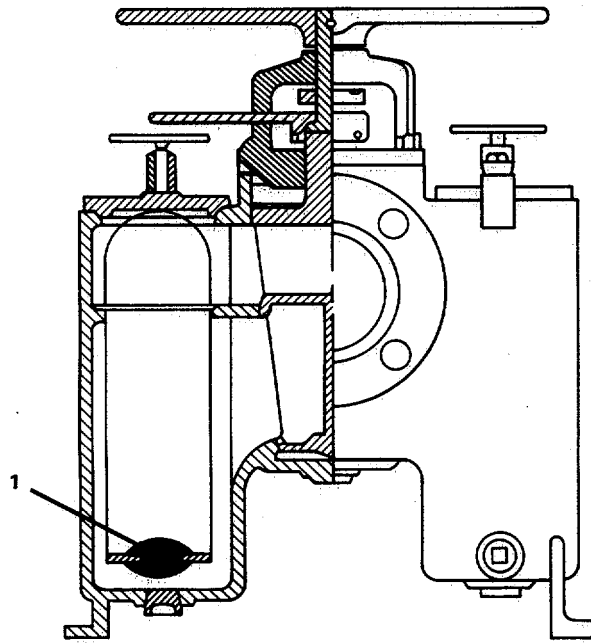

FIGURE 3-203. 3-Inch Duplex Sediment Strainer, Repair.

3-680



MAINTENANCE OF PIPING SYSTEM, POTABLE WATER

**3-216. Replace/Repair Vent Valve. (Figure 3-204)**

**This task covers:**            **a. Removal,**            **b. Repair,**            **c. Replacement.**

**INITIAL SETUP**

<p><u>Tools</u></p> <p>Tool kit, general mechanic's, 5180-00-699-5273</p> <p>Tool kit, welder, 5180-00-754-0661</p> <p>Torch outfit, cutting and welding medium duty, oxygen and acetylene, 3433-00-357-8116</p> <p><u>Material/Parts</u></p> <p>Piping system, potable water P/N 8532028, refer to TM 55-1905-223-24P</p> <p>Warning tags, Item 1, Appendix C</p>	<p><u>Equipment Condition</u></p> <p>At Auxiliary Machinery Motor Control Center press No. 1 fresh water pump STOP pushbutton and set P205-4 circuit breaker to the OFF position. Press No. 2 fresh water pump STOP pushbutton and set P205-5 circuit breaker to the OFF position. Tag switches "Out of Service - Do Not Operate."</p>
--	--

**WARNING**

Use extreme care when disconnecting. Escaping system pressure or fluid could cause injury.

NOTE

All welded fittings are replaced in the same manner.

**REMOVAL**

Remove vent valve (1) from vent pipe (2) by cutting valve (1) from vent pipe (3); refer to TB 55-1900-201-45/1.

**REPAIR**

Repair at this level of maintenance is by replacement of vent valve (1).

## REPLACEMENT

- a. Weld vent valve (1) on vent pipe (2); refer to TB 55-1900-204-24.
- b. Operational check.
  - (1) Remove warning tags.
  - (2) Operate system; refer to TM 55-1905-223-10.
  - (3) Check for leaks in system and reseal connections as necessary.

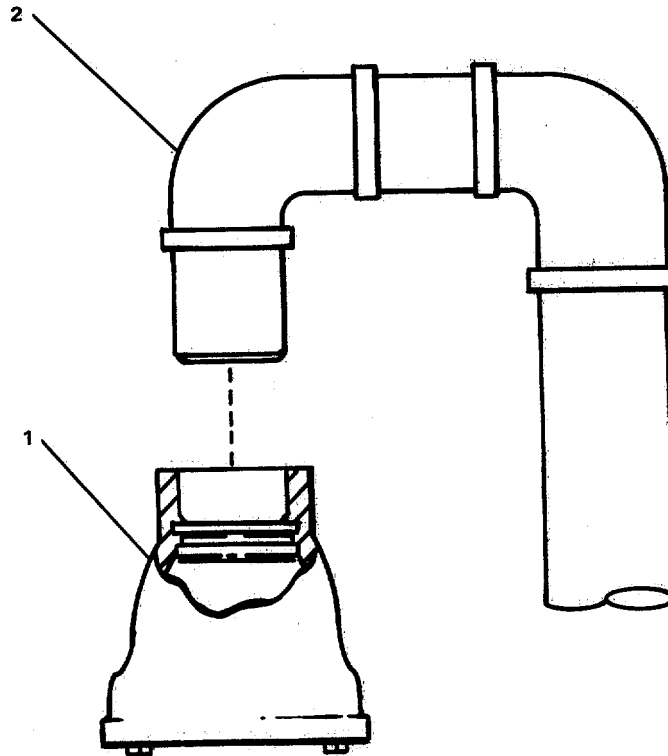

FIGURE 3-204. *Repair Vent Valve (Typical).*

**3-217. Replace/Repair Welded Fittings. (Figure 3-205)**

---

**This task covers:**    **a. Removal,**    **b. Repair,**    **c. Replacement.**

---

**INITIAL SETUP**

Tools	Equipment Condition
Tool kit, general mechanic's, 5180-00-699-5273	At Auxiliary Machinery Motor Control Center press No. 1 fresh water pump STOP pushbutton and set P205-4 circuit breaker to the OFF position. Press No. 2 fresh water pump STOP pushbutton and set P205-5 circuit breaker to the OFF position. Tag switches "Out of Service - Do Not Operate."
Tool kit, welder, 5180-00-754-0661	
Torch outfit, cutting and welding medium duty, oxygen and acetylene 3433-00-357-8116	
Materials/Parts	
Piping system, potable water P/N 8532028, refer to TM 55-1905-223-24P	
Warning tags, Item 1, Appendix C	

---

**REMOVAL****WARNING**

Use extreme care when disconnecting. Escaping system pressure or fluid could cause injury.

**NOTE**

All welded fittings are replaced in the same manner.

- a. Isolate fitting (3) from piping system.
  - (1) Trace inlet piping (2) to nearest manually operated shutoff valve (1).
  - (2) Close shutoff valve (1).
  - (3) Trace outlet piping (4) to nearest manually operated shutoff valve (5).
  - (4) Close shutoff valve (5).
- b. Remove fitting (3) from piping system. Cut fitting (3) from piping (2, 4); refer to TB 55-1900-201-45/1.

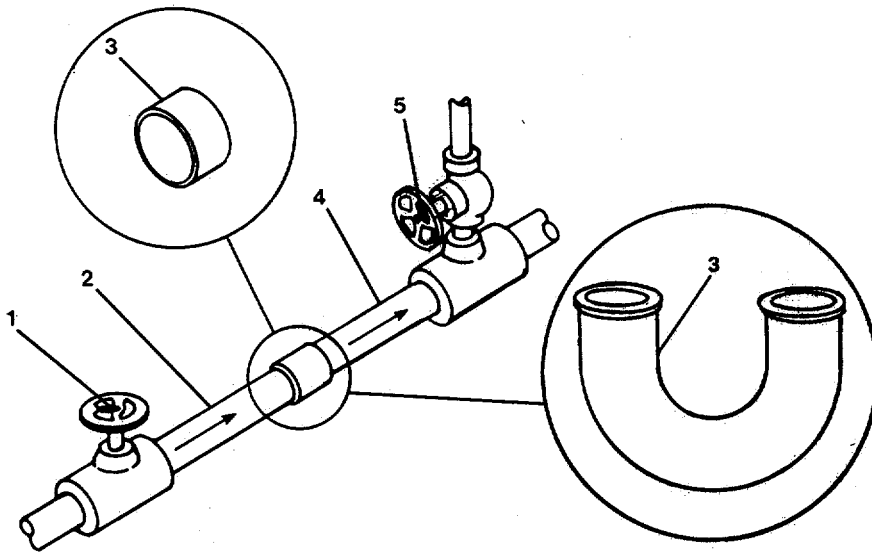

FIGURE 3-205. *Repair Welded Fittings (Typical).*

## REPAIR

Repair at this level of maintenance is by replacement of the welded fitting (3).

## REPLACEMENT

- a. Install fitting (3) in piping system.
  - (1) Position fitting (3) between inlet piping (2) and outlet piping (4).
  - (2) Weld fitting (3) to piping; refer to TB 55-1900-204-24.
- b. Operational check.
  - (1) Remove warning tags.
  - (2) Operate system; refer to TM 55-1905-223-10.
  - (3) Open inlet shutoff valve (1) and outlet shutoff valve (5).
  - (4) Check for leaks in system and reseal connections as necessary.

---

**3-218. Replace/Repair Copper Solder Adapters/Connectors. (Figure 3-206)**

---

**This task covers: a. Removal, b. Repair, c. Replacement.**

---

**INITIAL SETUP**

Tools	Equipment Condition
Tool kit, general mechanic's, 5180-00-699-5273	At Auxiliary Machinery Motor Control Center press No. 1 fresh water pump STOP pushbutton and set P205-4 circuit breaker to the OFF position. Press No. 2 fresh water pump STOP pushbutton and set P205-5 circuit breaker to the OFF position. Tag switches "Out of Service - Do Not Operate."
Torch kit, soldering, L.P. Gas, 3439-00-342-0531	
Materials/ Parts	
Piping system, potable water P/N 8532028, refer to TM 55-1905-223-24P-4 Warning tags, Item 1, Appendix C	

---

**REMOVAL****WARNING**

Use extreme care when disconnecting. Escaping system pressure or fluid could cause injury.

**NOTE**

All copper solder adapters/connectors are replaced in the same manner.

- a. Isolate copper solder adapter/connector (3) from piping system.
  - (1) Trace inlet piping (2) to nearest manually operated shutoff valve (1).
  - (2) Close shutoff valve (1).
  - (3) Trace outlet piping (4) to nearest manually operated shutoff valve (5).
  - (4) Close shutoff valve (5).
- b. Remove copper solder adapter/connector (3) from piping (2, 4); refer to TB 55-1900-201-45/1.

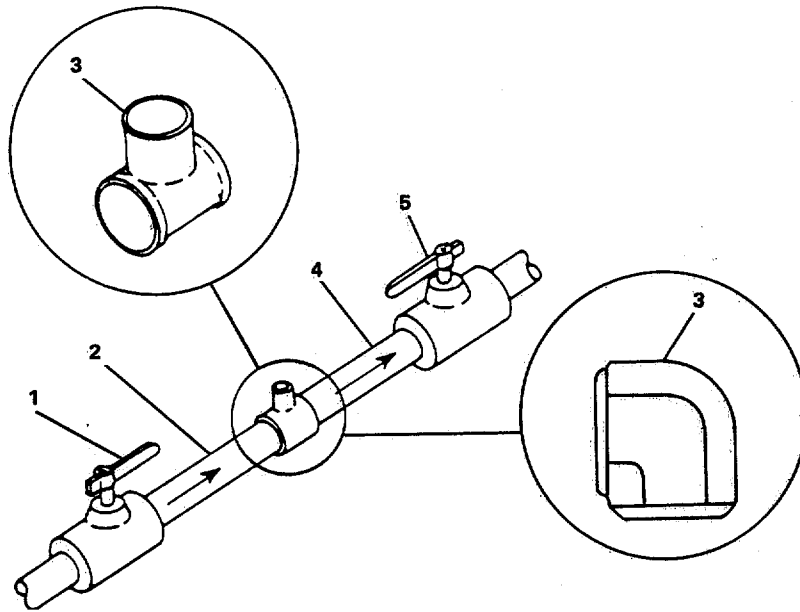

FIGURE 3-206. Repair Copper Solder Adapter Joints (Typical).

## REPAIR

Repair at this level of maintenance is by replacement of the copper solder adapter/connector (3). Refer to TB 55-1900-201-45/1.

## REPLACEMENT

- a. Install copper solder adapter/connector (3) in piping system.
  - (1) Position solder adapter/connector (3) between inlet piping (2) and outlet piping (4).
  - (2) Solder copper adapter/connector joint (3); refer to TB 55-1900-201-45/1 for procedures.
- b. Operational check.
  - (1) Remove warning tag and turn on electrical power at ship services switchboard.
  - (2) Operate system; refer to TM 55-1905-223-10.
  - (3) Open inlet valve (1) and outlet valve (5).
  - (4) Check for leaks in system and reseal connection as necessary.

---

**3-219. Replace/Repair Hydropneumatic Tank. (Figure 3-207)**

---

**This task covers:**                    **a. Removal,**        **b. Repair,**            **c. Replacement.**

---

**INITIAL SETUP**

<u>Tools</u>	<u>Equipment Condition</u>
Tool kit, general mechanic's, 5180-00-699-5273 Torque wrench kit P/N 3377216	At Auxiliary Machinery Motor Control Center press No. 1 fresh water pump STOP pushbutton and set P205-4 circuit breaker to the OFF position. Press No. 2 fresh water pump STOP pushbutton and set P205-5 circuit breaker to the OFF position. Tag switches "Out of Service - Do Not Operate."
<u>Materials/Parts</u>  Piping system, potable water P/N 8532028, refer to TM 55-1905-223-24P Anti-seize compound, Item 15, Appendix C Warning tags, Item 1, Appendix C	

---

**REMOVAL**

**WARNING**

Use extreme care when disconnecting. Escaping system pressure or fluid could cause injury.

- a. Close fresh water pump discharge valve (4).
- b. Close hydropneumatic tank discharge valve (6).
- c. Open drain valve and drain tank (1).
- d. Disconnect water supply piping (5) and tank discharge piping (7).
- e. Remove nut (3), bolt (11) and strap (2) from tank (1).
- f. Remove nuts (8) and bolts (10) from tank bottom supports (9).
- g. Remove hydropneumatic tank (1).

**REPAIR**

Repair at this level of maintenance is by replacement of the hydropneumatic tank (1).

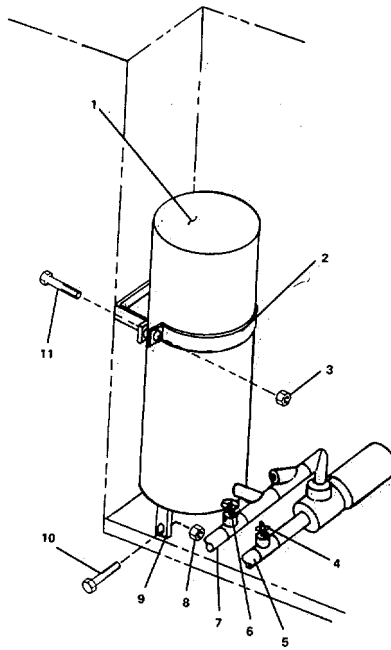

FIGURE 3-207. Repair Hydropneumatic Tank.

## REPLACEMENT

### NOTE

Coat all threaded connections with anti-seize compound prior to installation.

- a. Place hydropneumatic tank (1) in position.
- b. Install bolt (10) and nut (8) in tank bottom supports (9) but do not tighten yet.
- c. Position strap (2) on tank (1) and install bolt (11) and nut (3).
- d. Torque all mount bolts to 18 ft-lb (24 Nm).
- e. Connect tank discharge piping (7) and water supply piping (5).
- f. Close drain valve.
- g. Open hydropneumatic tank discharge valve (6).
- h. Open fresh water pump discharge valve (4).
- i. Remove warning tags.
- j. Operate system; refer to TM 55-1905-223-10.
- k. Check for leaks and retighten connections as necessary.



**3-220. Replace/Repair Hot Water Heater.**

This task covers: a. Removal, b. Disassembly, c. Repair, d. Assembly.  
e. Replacement.

**INITIAL SETUP**Tools

Tool kit, general mechanic's,  
5180-00-699-5273  
Tool kit, electrician,  
5180-00-391-1087  
Torque wrench kit P/N 3377216

Equipment Condition

At ship service switchboard, set HOT  
WATER HEATER circuit breaker to OFF  
position. Tag switch "Out of  
Service - Do Not Operate."

Materials/Parts

Hot water heater P/N DSE-80- 12  
Thermostatic switch P/N 5107  
Thermostatic switch P/N 5130- 1 00  
Teflon tape, Item 5, Appendix C  
Warning tags, Item 1, Appendix C  
Anode, corrosion P/N 5206-39  
(P/N 5206-18 for 2001-2003)

**WARNING**

To prevent burns to personnel from hot water heater, ensure that water heater has been turned off 24 hours prior to any work to allow water and parts to cool before performing maintenance.

**REMOVAL**

- a. Close hot water supply valve (1, Figure 3-208).
- b. Close cold water isolation valve (3).
- c. Drain hot water heater (12) through drain faucet (9).
- d. Open hinged access door (10).
- e. Install tags and disconnect electrical leads at terminal block (11).
- f. Close hinged access door (10).
- g. Disconnect cold water piping (6) and hot water piping (2).
- h. Remove bolts (7) and nuts (8) from base of hot water heater.

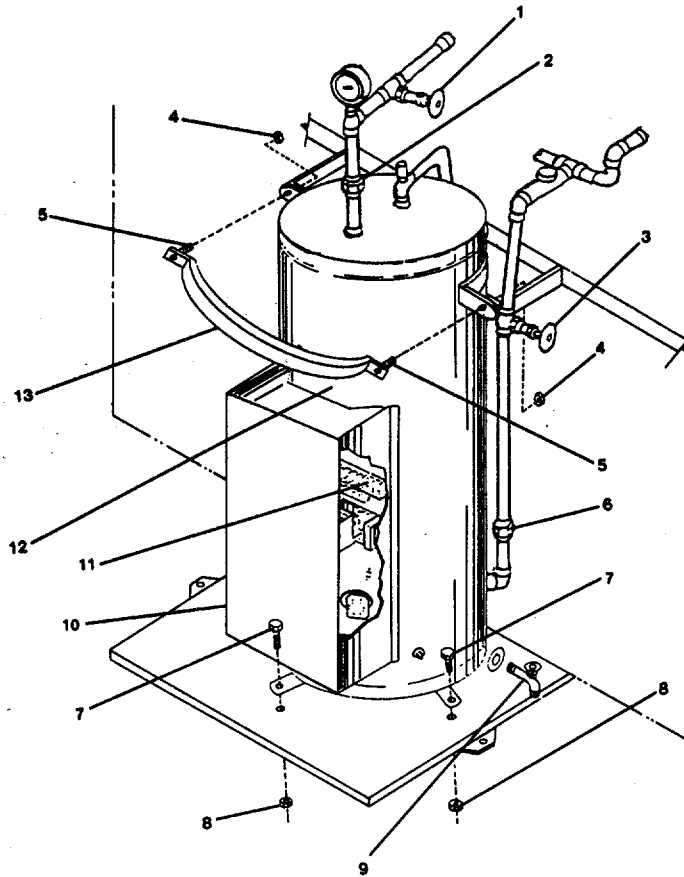

FIGURE 3-208. Hot Water Heater Removal.

i. Remove bolts (5) and nuts (4) and remove strap (13) from hot water heater (12).

J. Remove hot water heater (12).

**DISASSEMBLY**

a. Remove top cover plugs (3, Figure 3-209) from hot water heater (1).

b. Remove thermostatic switch (2).

c. Remove corrosion preventive anode (4).

d. Open hinged access door (7).

e. Remove fuse block (5), transformer (6), thermostatic switch (8), and contactor (9).

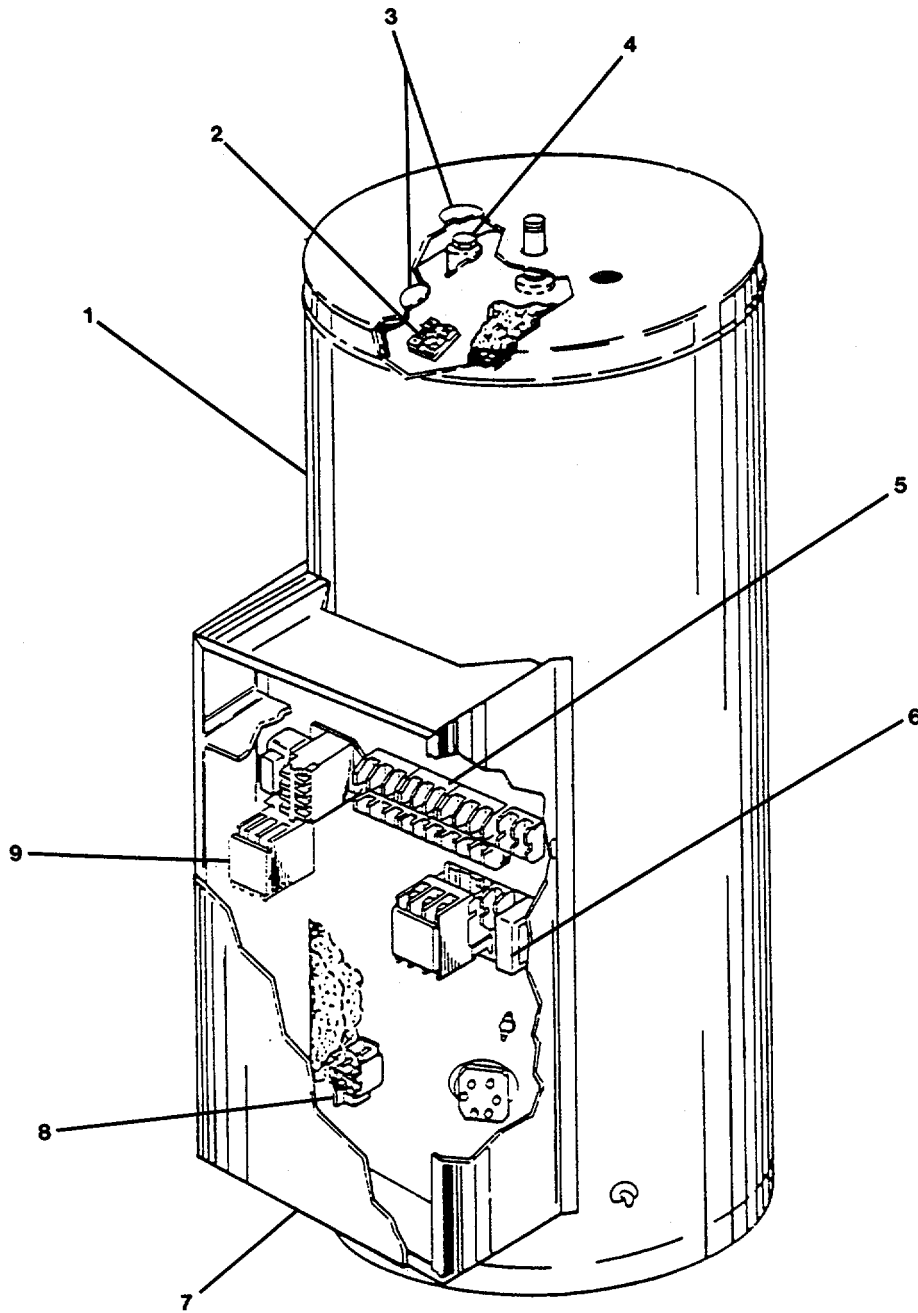

FIGURE 3-209. *Hot Water Heater Repair.*

**REPAIR**

Repair to the hot water heater at this level of maintenance is by replacement of hot water heater (12, Figure 3-208), corrosion preventive anode (4), thermostatic switch (2), fuse block (5), transformer (6), thermostatic switch (8) and contactor (9).

**ASSEMBLY**

- a. Install contactor (9, Figure 3-209), thermostatic switch (8), transformer (6), fuse block (5).
- b. Close hinged access door (7).
- c. Install corrosion preventive anode (4) and thermostatic switch (2).
- d. Install top cover plugs (3) on hot water heater (1).

**REPLACEMENT****NOTE**

Apply teflon tape to all connections prior to installation.

- a. Place hot water heater (12, Figure 3-208) in position.
- b. Install strap (13) on hot water heater (12) and secure using bolts (5) and nuts (4). Do not tighten yet.
- c. Install bolts (7) and nuts (8) on base of hot water heater (12).
- d. Torque all mount bolts to 18 ft-lb (24 Nm).
- e. Connect hot water piping (2) and cold water piping (6).
- f. Open hinged access door (10).
- g. Remove tags and connect electrical leads to terminal block (11).
- h. Open cold water isolation valve (3).
- i. Open hot water supply valve (1).
- j. Remove warning tag and turn on electrical power at 240V main switchboard.
- k. Check hot water heater for leaks and proper operation.
- l. Close hinged access door (10).

MAINTENANCE OF PIPING SYSTEM, BILGE BALLAST AND FIREMAIN

**3-221. Replace/Repair Welded Fittings.**

**This task covers: a. Removal, b. Repair, c. Replacement.**

**INITIAL SETUP**

Tools

Tool kit, general mechanic's,  
5180-00-699-5273  
Tool kit, welder, 5180-00-734-0661  
Torch outfit, cutting and welding  
medium duty, oxygen and acetylene,  
3433-00-357-8116

Materials/Parts

Piping system, bilge ballast and  
firemain P/N 8529024, refer to  
TM 55-1905-223-24P  
Warning tags, Item 1, Appendix C

Equipment Condition

At Ship Service Switchboard, set  
BILGE/BALLAST circuit breaker to the  
OFF position. Set FIRE PUMP 1 and  
FIRE PUMP 2 circuit breakers to the  
OFF position. Tag switches "Out of  
Service - Do Not Operate."

General Safety Instructions

**WARNING**

\*Ensure system is turned OFF and  
tagged to prevent operation during  
maintenance. Generated pressure  
could cause injury.

\* Use extreme care when breaking system  
connections. Escaping pressure  
and/or fluids could cause injury.

\* Clean up spills immediately. Spills  
create an unsafe working area.

Refer to paragraph 3-217 for procedures.

---

**3-222. Replace/Repair Flanged Valves.**

---

This task covers:    a. Removal,   b. Repair,   c. Replacement.

---

**INITIAL SETUP**Tools

Tool kit, general mechanic's,  
5180-00-699-5273

Materials/Parts

Piping system, bilge ballast and  
firemain P/N 8529024, refer to  
TM 55-1905-223-24P  
Warning tags, Item 1, Appendix C  
Utility pail, Item 13, Appendix C

Equipment Condition

At Ship Service Switchboard, set  
BILGE/BALLAST circuit breaker to the  
OFF position. Set FIRE PUMP 1 and  
FIRE PUMP 2 circuit breakers to the  
OFF position. Tag switches "Out of  
Service - Do Not Operate."

## General Safety Instructions

**WARNING**

\* Ensure system is turned OFF and  
tagged to prevent operation during  
maintenance. Generated pressure  
could cause injury.

\* Use extreme care when breaking system  
connections. Escaping pressure  
and/or fluids could cause injury.

\* Clean up spills immediately. Spills  
create an unsafe working area.

---

Refer to paragraph 2-330 for procedures.

---

**3-223. Replace/Repair Pipe Hangers. (Figure 3-210).**

---

This task covers:    a. Removal                    b. Repair.                    c. Replacement.

---

**INITIAL SETUP:**

---

Tools

Tool kit, general mechanic's,  
5180-00-699-5273

Materials/Parts

Piping system, bilge ballast and firemain P/N 8529024, refer to TM 55-1905-223-24P

---

**REMOVAL**

---

- a. Remove nuts (6) and bolts (3) from pipe hanger (5).
- b. Remove upper half of pipe clamp (4).
- c. Remove nuts (2) and bolts (1) from pipe hanger (5).
- d. Remove pipe hanger (5).

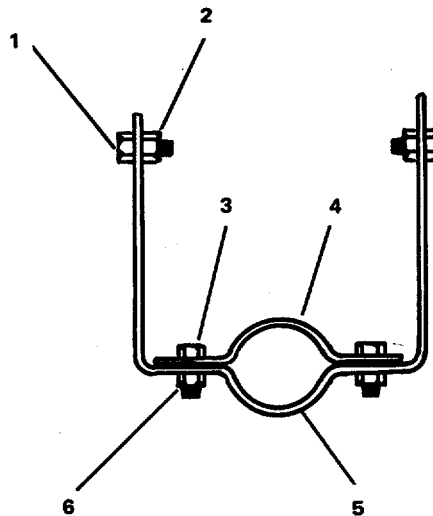

FIGURE 3-210. Repair Pipe Hangers (Typical).

**REPAIR**

Repair at this level of maintenance is by replacement of the pipe hangers (5).

**REPLACEMENT**

- a. Position pipe hanger (5) on pipe and secure using bolts (1) and nuts (2).
- b. Install upper half of pipe clamp (4).
- c. Secure using bolts (3) and nuts (6).



**MAINTENANCE OF PIPING SYSTEM, SEA WATER COOLING**

**3-224. Replace/Repair Threaded Valves.**

**This task covers:    a. Removal                    b. Repair.                    c. Replacement.**

**INITIAL SETUP:**

Tools

Tool kit, general mechanic's,  
5180-00-699-5273

Materials/Parts

Piping system, seawater cooling  
P/N 8256009, refer to  
TM 55-1905-223-24P  
Warning tags, Item 1, Appendix C  
Utility pail, Item 13, Appendix C

Equipment Condition

At Ship Service switchboard set  
Bilge/Ballast Pump circuit breaker to  
the OFF position. Set Fire Pump No.  
1 and Fire Pump No. 2 circuit  
breakers to the OFF position. Tag  
switches "Out of Service - Do Not  
Operate."

**REMOVAL**

Refer to paragraph 3-217 for procedures.

---

**3-225. Replace/Repair Welded Fittings**

---

**This task covers:    a. Removal                    b. Repair.                    c. Replacement.**

---

**INITIAL SETUP:**

Tools

Tool kit, general mechanic's,  
5180-00-699-5273  
Torch outfit, cutting and welding  
medium duty, oxygen and  
acetylene, 3433-00-357-8116  
Tool kit, welder, 5180-00-754-0661

Equipment Condition

Stop the auxiliary seawater pump at  
the auxiliary machinery motor control  
center and set the A.C.S.W. cooling  
pump circuit breaker to the OFF  
position. Tag switches "Out of  
Service - Do Not Operate."

Materials/Parts

Piping system, seawater cooling  
P/N 8256009, refer to  
TM 55-1905-223-24P  
Warning tags, Item 1, Appendix C  
Utility pail, Item 13, Appendix C

General Safety Instructions

WARNING

- Ensure system is turned OFF and tagged to prevent operation during maintenance. Generated pressure could cause injury.
- Use extreme care when breaking system connections. Escaping pressure and/or fluids could cause injury.
- Clean up spills immediately. Spills create an unsafe working area.

---

**REMOVAL**

Refer to paragraph 3-217 for procedures.

**3-226. Replace/Repair Welded Bar, Angles and Bar Round Plates . (Figure 3-211).**

---

**This task covers:    a. Removal                    b. Repair.                    c. Replacement.**

---

**INITIAL SETUP:**Tools

Tool kit, general mechanic's,  
5180-00-699-5273  
Torch outfit, cutting and welding  
medium duty, oxygen and  
acetylene, 3433-00-357-8116  
Tool kit, welder, 5180-00-754-0661

Equipment Condition

Stop the auxiliary seawater pump at  
the auxiliary machinery motor control  
center and set the A.C.S.W. cooling  
pump circuit breaker to the OFF  
position. Tag switches "Out of  
Service - Do Not Operate."

Materials/Parts

Piping system, seawater cooling  
P/N 8256009, refer to  
TM 55-1905-223-24P  
Warning tags, Item 1, Appendix C

**REMOVAL****NOTE**

Refer to TM 55-1900-204-24 for detailed cutting and welding  
procedures.

- a. Remove bar angle (1) by cutting torch.
- b. Remove bar round plate (2) by cutting torch.

**REPAIR**

Repair at this level of maintenance is by replacement of the bar  
angles and bar round plates.

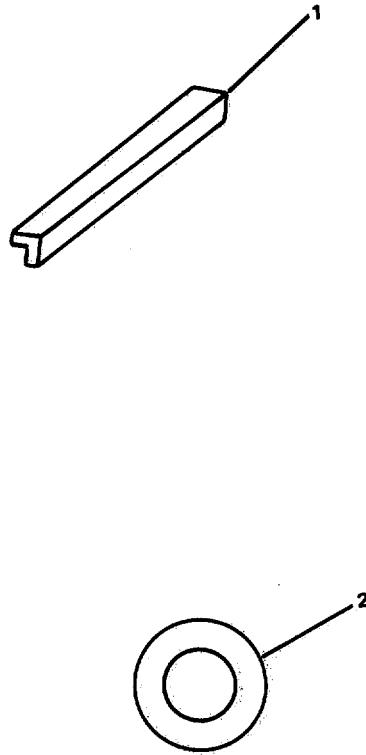

FIGURE 3-211. Repair Bar Angles and Bar Round Plates (Typical).

**ASSEMBLY**

- a. Install bar angle (1) by welding torch.
- b. Install bar round plate (2) by welding torch.

---

**3-227. Replace/Repair Pipe Hangers.**

---

**This task covers:    a. Removal                    b. Repair.                    c. Replacement.**

---

**INITIAL SETUP:**

Tools

Tool kit, general mechanic's,  
5180-00-699-5273

Materials/Parts

Piping system, seawater cooling  
P/N 8256009, refer to  
TM 55-1905-223-24P

**REMOVAL**

Refer to paragraph 3-223 for procedures.

<b>MAINTENANCE OF PIPING SYSTEM, FRESH WATER COOLING</b>
--

**3-228. Replace/Repair Welded Valves. (Figure 3-212).**

---

**This task covers:**    **a. Removal**                      **b. Repair.**                      **c. Replacement.**

---

**INITIAL SETUP:**Tools

Tool kit, general mechanic's.  
5180-00-699-5273  
Torch outfit, cutting and welding  
medium duty, oxygen and  
acetylene, 3433-00-357-8116  
Tool kit, welder, 5180-00-754-0661

Equipment Condition

Stop the fresh water cooling pump  
at the Auxiliary Machinery Motor  
Control Center and set circuit  
breaker P205-4 to the OFF position.  
Tag switches "Out of Service - Do Not  
Operate."

Materials/Parts

Piping system, Fresh water  
cooling P/N 8532027, refer  
to TM 55-1905-223-24P  
Warning tags, Item 1, Appendix C  
Utility pail, Item 13, Appendix C

**REMOVAL**

---

**WARNING**

---

Ensure system is turned OFF and tagged to prevent operation during maintenance. Generated pressure could cause injury.

**NOTE**

All welded type valves are replaced in the same manner.

- a. Isolate valve from system.
- (1) Trace inlet piping (2) to nearest isolation valve.
- (2) Close isolation valve (1).

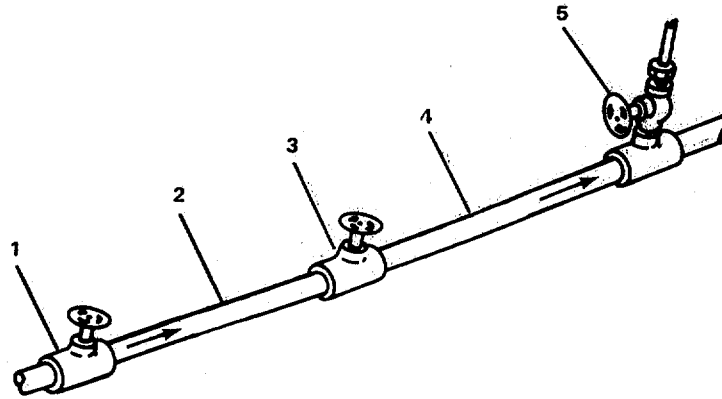

FIGURE 3-212. Repair Welded Valves (Typical).

- (3) Trace outlet piping (4) to nearest isolation valve.
  - (4) Close isolation valve (5).
- b. Remove valve from system.

#### WARNING

- Use extreme care when breaking system connections. Escaping pressure and/or fluids could cause injury.
- Clean up spills immediately. Spills create an unsafe working area.

- (1) Position pail to catch spillage.
- (2) Remove valve (3) from piping system; refer to TB 55-1900-201-45/1 for detailed procedures.

#### REPAIR

Repair at this level of maintenance is by replacement of the welded valves.

#### REPLACEMENT

- a. Install valve in system.
  - (1) Position valve (3) in piping system and weld; refer to TM 55-1900-204-24, for detailed procedures.



b. Operation check of system.

- (1) Remove warning tags.
- (2) At Engine Room, Auxiliary Control Center, set circuit breaker P205-4 to the ON position and press the START pushbutton for the fresh water cooling pump.
- (3) Open isolation valves (1 and 5).
- (4) Check system for leaks and proper operation. Reset connections as necessary.

**3-229. Replace/Repair Butterfly Valves**

**This task covers:**    **a. Removal**                      **b. Repair.**                      **c. Replacement.**

**INITIAL SETUP:**

Tools

Tool kit, general mechanic's,  
5180-00-699-5273

Materials/Parts

Piping system, fresh water  
cooling P/N 8532027, refer  
to TM 55-1905-223-24P  
Warning tags, Item 1, Appendix C  
Utility pail, Item 13, Appendix C

Equipment Condition

Stop the fresh water cooling pump  
at the Auxiliary Machinery Motor  
Control Center and set circuit  
breaker P205-4 to the OFF position.  
Tag switches "Out of Service - Do Not  
Operate."

General Safety Instructions

**WARNING**

- Ensure system is turned OFF and tagged to prevent operation during maintenance. Generated pressure could cause injury.
- Use extreme care when breaking system connections. Escaping pressure and/or fluids could cause injury.
- Clean up spills immediately. Spills create an unsafe working area.

**REMOVAL**

Refer to paragraph 2-331 for procedures.

---

**3-230. Replace/Repair Flanged Valves.**

---

**This task covers:**    **a. Removal**                      **b. Repair.**                      **c. Replacement.**

---

**INITIAL SETUP:**

Tools

Tool kit, general mechanic's,  
5180-00-699-5273

Materials/Parts

Piping system, fresh water  
cooling P/N 8532027, refer  
to TM 55-1905-223-24P  
Warning tags, Item 1, Appendix C  
Utility pail, Item 13, Appendix C

Equipment Condition

Stop the fresh water cooling pump  
at the Auxiliary Machinery Motor  
Control Center and set circuit  
breaker P205-4 to the OFF position.  
Tag switches "Out of Service - Do Not  
Operate."

General Safety Instructions

**WARNING**

- Ensure system is turned OFF and tagged to prevent operation during maintenance. Generated pressure could cause injury.
- Use extreme care when breaking system connections. Escaping pressure and/or fluids could cause injury.
- Clean up spills immediately. Spills create an unsafe working area.

**REMOVAL**

Refer to paragraph 2-330 for procedures.

**3-231. Replace/Repair Welded Fittings.**

**This task covers:**    **a. Removal**                      **b. Repair.**                      **c. Replacement.**

**INITIAL SETUP:**

Tools

Tool kit, general mechanic's,  
5180-00-699-5273  
Torch outfit, cutting and  
welding medium duty, oxygen  
and acetylene, 3433-00-357-8116  
Tool kit, welder, 5180-00-754-0661

Equipment Condition

Stop the fresh water cooling pump  
at the Auxiliary Machinery Motor  
Control Center and set circuit  
breaker P205-4 to the OFF position.  
Tag switches "Out of Service - Do Not  
Operate."

Materials/Parts

Piping system, fresh water  
cooling P/N 8532027, refer  
to TM 55-1905-223-24P  
Warning tags, Item 1, Appendix C  
Utility pail, Item 13, Appendix C

General Safety Instructions

**WARNING**

- Ensure system is turned OFF and tagged to prevent operation during maintenance. Generated pressure could cause injury.
- Use extreme care when breaking system connections. Escaping pressure and/or fluids could cause injury.
- Clean up spills immediately. Spills create an unsafe working area.

**REMOVAL**

Refer to paragraph 3-217 for procedures.

---

**3-232. Replace/Repair Pipe Hangers.**

---

**This task covers:    a. Removal                    b. Repair.                    c. Replacement.**

---

**INITIAL SETUP:**

Tools

Tool kit, general mechanic's,  
5180-00-699-5273

Materials/Parts

Piping system, fresh water cooling  
P/N 8532027, refer to  
TM 55-1905-223-24P

**REMOVAL**

Refer to paragraph 3-223 for procedures.

**MAINTENANCE OF PIPING SYSTEM, COMPRESSED AIR**

**3-233. Replace/Repair Welded Fittings.**

**This task covers:    a. Removal                    b. Repair.                    c. Replacement.**

**INITIAL SETUP:**

Tools

Tool kit, general mechanic's,  
5180-00-699-5273  
Torch outfit, cutting and  
welding medium duty, oxygen  
and acetylene, 3433-00-357-8116  
Tool kit, welder, 5180-00-754-0661

Equipment Condition

On Auxiliary Machinery Motor Control  
Center, press Air Compressor No. 1  
and No. 2 STOP pushbutton and set  
breakers to the OFF position.  
Tag switches "Out of Service - Do Not  
Operate."

Materials/Parts

Piping system, compressed air  
P/N 8532027, refer to  
TM 55-1905-223-24P  
Warning tags, Item 1, Appendix C  
Utility pail, Item 13, Appendix C

General Safety Instructions

**WARNING**

- Ensure system is turned OFF and tagged to prevent operation during maintenance. Generated pressure could cause injury.
- Use extreme care when breaking system connections. Escaping pressure and/or fluids could cause injury.
- Clean up spills immediately. Spills create an unsafe working area.

**REMOVAL**

Refer to paragraph 3-217 for procedures.

---

**3-234. Replace/Repair Pipe Hangers.**

---

**This task covers:**    **a. Removal**                      **b. Repair.**                      **c. Replacement.**

---

**INITIAL SETUP:**

Tools

Tool kit, general mechanic's,  
5180-00-699-5273

Materials/Parts

Piping system, compressed air  
P/N 8551031, refer to  
TM 55-1905-223-24P

**REMOVAL**

Refer to paragraph 3-223 for procedures.

**MAINTENANCE OF PIPING SYSTEM, FIRE MONITOR AND WASHDOWN**

**3-235. Replace/Repair Brazed Fittings.**

**This task covers:    a. Removal                    b. Repair.                    c. Replacement.**

**INITIAL SETUP:**

Tools

Tool kit, general mechanic's,  
5180-00-699-5273  
Torch outfit, cutting and  
welding medium duty, oxygen  
and acetylene, 3433-00-357-8116  
Tool kit, welder, 5180-00-754-0661

Equipment Condition

At Ship Service switchboard, set FIRE  
PUMP 1 and FIRE PUMP 2 circuit  
breakers to the OFF position. Tag  
switches "Out of Service - Do Not  
Operate."

Materials/Parts

Piping system, fire monitor and  
washdown P/N 8555032, refer to  
TM 55-1905-223-24P  
Warning tags, Item 1, Appendix C  
Utility pail, Item 13, Appendix C

General Safety Instructions

**WARNING**

- Ensure system is turned OFF and tagged to prevent operation during maintenance. Generated pressure could cause injury.
- Use extreme care when breaking system connections. Escaping pressure and/or fluids could cause injury.

Clean up spills immediately. Spills create an unsafe working area.

**REMOVAL**

Refer to paragraph 3-218 for procedures.



---

**3-236. Replace/Repair Welded Fittings.**

---

**This task covers:**    **a. Removal**                      **b. Repair.**                      **c. Replacement.**

---

**INITIAL SETUP:**

Tools

Tool kit, general mechanic's,  
5180-00-699-5273  
Torch outfit, cutting and  
welding medium duty, oxygen  
and acetylene, 3433-00-357-8116  
Tool kit, welder 5180-00-754-0661

Equipment Condition

At Ship Service Switchboard, set FIRE  
PUMP 1 and FIRE PUMP 2 circuit  
breakers to the OFF position. Tag  
switches "Out of Service - Do Not  
Operate."

Materials/Parts

Piping system, fire monitor and  
washdown P/N 8555032, refer to  
TM 55-1905-223-24P  
Warning tags, Item 1, Appendix C  
Utility pail, Item 13, Appendix C

General Safety Instructions

WARNING

- Ensure system is turned OFF and tagged to prevent operation during maintenance. Generated pressure could cause injury.
- Use extreme care when breaking system connections. Escaping pressure and/or fluids could cause injury.
- Clean up spills immediately. Spills create an unsafe working area.

---

**REMOVAL**

Refer to paragraph 3-217 for procedures.

---

**3-237. Replace/Repair Pipe Hangers.**

---

**This task covers:**    **a. Removal**                      **b. Repair.**                      **c. Replacement.**

---

**INITIAL SETUP:**

Tools

Tool kit, general mechanic's,  
5180-00-699-5273

Materials/Parts

Piping system, fire monitor and  
washdown P/N 8555032, refer to  
TM 55-1905-223-24P

---

**REMOVAL**

Refer to paragraph 3-223 for procedures.

**MAINTENANCE OF PIPING SYSTEM, LUBE OIL TRANSFER/DIRTY OIL DISCHARGE**

**3-238. Replace/Repair Welded Valves**

**This task covers:    a. Removal                      b. Repair.                      c. Replacement.**

**INITIAL SETUP:**

Tools

Tool kit, general mechanic's,  
5180-00-699-5273  
Torch outfit, cutting and  
welding medium duty, oxygen  
and acetylene, 3433-00-357-8116  
Tool kit, welder. 5180-00-754-0661

Materials/Parts

Piping system, lube oil transfer/  
dirty oil discharge P/N 8262011,  
refer to TM 55-1905-223-24P  
Warning tags, Item 1, Appendix C  
Utility pail, Item 13, Appendix C

Equipment Condition

At the Auxiliary Machinery Motor  
Control Center, press STOP pushbutton  
on Lube Oil Purifier switch and set  
circuit breaker to the OFF position.  
Press STOP pushbutton on Dirty Lube  
Oil pump switch and set circuit  
breaker to the OFF position. Tag  
switches "Out of Service - Do Not  
Operate."

General Safety Instructions

**WARNING**

- Ensure system is turned OFF and tagged to prevent operation during maintenance. Generated pressure could cause injury.
- Use extreme care when breaking system connections. Escaping pressure and/or fluids could cause injury.
- Clean up spills immediately. Spills create an unsafe working area.
- Exercise extreme caution when working with flammables.

**REMOVAL**

Refer to paragraph 3-228 for procedures.

---

**3-239. Replace/Repair Welded Fittings**

---

**This task covers:**    **a. Removal**                      **b. Repair.**                      **c. Replacement.**

---

**INITIAL SETUP:**

Tools

Tool kit, general mechanic's,  
5180-00-699-5273  
Torch outfit, cutting and  
welding medium duty, oxygen  
and acetylene, 3433-00-357-8116  
Tool kit, welder, 5180-00-754-0661

Materials/Parts

Piping system, lube oil transfer/  
dirty oil discharge P/N 8262011,  
refer to TM 55-1905-223-24P  
Warning tags, Item 1, Appendix C  
Utility tags, Item 13, Appendix C

Equipment Condition

At the Auxiliary Machinery Motor  
Control Center, press STOP pushbutton  
on Lube Oil Purifier switch and set  
circuit breaker to the OFF position.  
Press STOP pushbutton on Dirty Lube  
Oil pump switch and set circuit  
breaker to the OFF position. Tag  
switches "Out of Service - Do Not  
Operate."

General Safety Instructions

**WARNING**

- Ensure system is turned OFF and tagged to prevent operation during maintenance. Generated pressure could cause injury.
- Use extreme care when breaking system connections. Escaping pressure and/or fluids could cause injury.
- Clean up spills immediately. Spills create an unsafe working area.
- Exercise extreme caution when working with flammables.

---

**REMOVAL**

---

Refer to paragraph 3-217 for procedures.

---

**3-240. Replace/Repair Pipe Hangers.**

---

**This task covers:    a. Removal                    b. Repair.                    c. Replacement.**

---

**INITIAL SETUP:**

Tools

Tool kit, general mechanic's,  
5180-00-699-5273

Materials/Parts

Piping system, lube oil transfer/  
dirty oil discharge P/N 8262011,  
refer to TM 55-1905-223-24P

**REMOVAL**

Refer to paragraph 3-223 for procedures.

---

**3-241. Replace/Repair Rotary Hand Pump.**

---

**This task covers:    a. Removal                    b. Repair.                    c. Replacement.**

---

**INITIAL SETUP:**

Tools

Tool kit, general mechanic's,  
5180-00-699-5273

Materials/Parts

Piping system, lube oil transfer/  
dirty oil discharge P/N 8262011,  
refer to TM 55-1905-223-24P

**REMOVAL**

Refer to paragraph 2-332 for procedures.

<b>MAINTENANCE OF PIPING SYSTEM, HYDRAULIC</b>
--

---

**3-242. Replace/Repair Welded Valves.**

---

**This task covers:    a. Removal                    b. Repair.                    c. Replacement.**

---

**INITIAL SETUP:**
Tools

Tool kit, general mechanic's,  
5180-00-699-5273  
Torch outfit, cutting and  
welding medium duty, oxygen  
and acetylene, 3433-00-357-8116  
Tool kit, welder, 5180-00-754-0661

Materials/Parts

Piping system, hydraulic P/N 8556010,  
refer to TM 55-1905-223-24P  
Utility pail, Item 13, Appendix C

General Safety Instructions
**WARNING**

- Ensure system is tagged to prevent operation during maintenance. Generated pressure could cause injury.
- Use extreme care when breaking system connections. Escaping pressure and/or fluids could cause injury.
- Clean up spills immediately. Spills create an unsafe working area.
- Exercise extreme caution when working with flammables.

---

**REMOVAL**

Refer to paragraph 3-228 for procedures.

**3-243. Replace/Repair Welded Fittings.**

**This task covers:    a. Removal                      b. Repair.                      c. Replacement.**

**INITIAL SETUP:**

Tools

Tool kit, general mechanic's,  
5180-00-699-5273  
Torch outfit, cutting and  
welding medium duty, oxygen  
and acetylene, 3433-00-357-8116  
Tool kit, welder 5180-00-754-0661

Materials/Parts

Piping system, hydraulic P/N 8556010  
refer to TM 55-1905-223-24P  
Utility pail, Item 13, Appendix C

General Safety Instructions

**WARNING**

- Ensure system is tagged to prevent operation during maintenance. Generated pressure could cause injury.
- Use extreme care when breaking system connections. Escaping pressure and/or fluids could cause injury.
- Clean up spills immediately. Spills create an unsafe working area.
- Exercise extreme caution when working with flammables.

**REMOVAL**

Refer to paragraph 3-217 for procedures.



---

**3-244. Replace/Repair Pipe Hangers.**

---

**This task covers:    a. Removal                    b. Repair.                    c. Replacement.**

---

**INITIAL SETUP:**

Tools

Tool kit, general mechanic's,  
5180-00-699-5273

Materials/Parts

Piping system, hydraulic P/N 8556010,  
refer to TM 55-1905-223-24P

**REMOVAL**

Refer to paragraph 3-223 for procedures.

---

**3-245. Replace/Repair Vent Valve.**

---

**This task covers:    a. Removal                    b. Repair.                    c. Replacement.**

---

**INITIAL SETUP:**

Tools

Tool kit, general mechanic's,  
5180-00-699-5273

Materials/Parts

Piping system, hydraulic P/N 8556010,  
refer to TM 55-1905-223-24P  
Anti-seize compound, Item 1, Appendix C

**REMOVAL**

Refer to paragraph 3-216 for procedures.

**MAINTENANCE OF PIPING SYSTEM, OILY WATER SEPARATOR**

---

**3-246. Replace/Repair Pipe Hangers.**

---

**This task covers:    a. Removal                    b. Repair.                    c. Replacement.**

---

**INITIAL SETUP:**

Tools

Tool kit, general mechanic's,  
5180-00-699-5273

Materials/Parts

Piping system, oily water  
separator P/N 8529025,  
refer to TM 55-1905-223-24P

---

**REMOVAL**

Refer to paragraph 3-223 for procedures.

**MAINTENANCE OF PIPING SYSTEM, BILGE MANIFOLD UNIT ASSEMBLY**

**3-247. Replace/Repair Welded Valves.**

**This task covers:    a. Removal                    b. Repair.                    c. Replacement.**

**INITIAL SETUP:**

Tools

Tool kit, general mechanic's,  
5180-00-699-5273  
Torch outfit, cutting and  
welding medium duty, oxygen  
and acetylene, 3433-00-357-8116  
Tool kit, welder, 5180-00-754-0661

Equipment Condition

Check Bilge Ballast and Firemain for  
leaks and corrosion.

General Safety Instructions

**WARNING**

- Ensure system is tagged to prevent operation during maintenance. Generated pressure could cause injury.
- Use extreme care when breaking system connections. Escaping pressure and/or fluids could cause injury.
- Clean up spills immediately. Spills create an unsafe working area.

Materials/Parts

Piping system, bilge manifold  
unit assembly P/N 8529050,  
refer to TM 55-1905-223-24P  
Warning tags, Item 1, Appendix C  
Utility pail, Item 13, Appendix C

**REMOVAL**

Refer to paragraph 3-228 for procedures.

3-248. REPLACE/REPAIR WELDED FITTINGS.

This task covers:

- a. Removal
- b. Repair
- c. Replacement

INITIAL SETUP:

Tools

Tool kit, general mechanic's,  
5180-00-699-5273  
Torch outfit, cutting and  
welding medium duty, oxygen  
and acetylene, 3433-00-357-8116  
Tool kit, welder, 5180-00-754-0661

Materials/Parts

Piping system, bilge manifold  
unit assembly P/N 8529050,  
refer to TM 55-1905-223-24P  
Warning tags, Item 1, Appendix C  
Utility pail, Item 13, Appendix C

General Safety Instructions

WARNING

- Ensure system is tagged to prevent operation during maintenance. Generated pressure could cause injury.
- Use extreme care when breaking system connections. Escaping pressure and/or fluids could cause injury.
- Clean up spills immediately. Spills create an unsafe working area.

REMOVAL

Refer to paragraph 3-217 for procedures.

---

3-249. REPLACE/REPAIR PIPE HANGERS.

---

This task covers:

- a. Removal
  - b. Repair
  - c. Replacement
- 

INITIAL SETUP:

Tools

Tool kit, general mechanic's,  
5180-00-699-5273

Materials/Parts

Piping system, bilge manifold  
unit assembly P/N 8529050,  
refer to TM 55-1905-223-24P

---

REMOVAL

Refer to paragraph 3-223 for procedures.

MAINTENANCE OF PIPING SYSTEM, FUEL TRANSFER PUMP UNIT ASSEMBLY
--

---

## 3-250. REPLACE/REPAIR WELDED VALVES.

This task covers:

- a. Removal
  - b. Repair
  - c. Replacement
- 

INITIAL SETUP:Tools

Tool kit, general mechanic's,  
5180-00-699-5273  
Torch outfit, cutting and  
welding medium duty, oxygen  
and acetylene, 3433-00-357-8116  
Tool kit, welder, 5180-00-754-0661  
injury.

Materials/Parts

Piping system, fuel transfer  
pump unit assembly P/N 8541051,  
refer to TM 55-1905-223-24P  
Warning tags, Item 1, Appendix C  
Utility pail, Item 13, Appendix C

General Safety InstructionsWARNING

- Ensure system is tagged to prevent operation during maintenance. Generated pressure could cause injury.
  - Use extreme care when breaking system connections. Escaping pressure and/or fluids could cause injury.
  - Clean up spills immediately. Spills create an unsafe working area.
  - Exercise extreme caution when working with flammables.
- 

## REMOVAL

Refer to paragraph 3-228 for procedures.

3-251. REPLACE/REPAIR WELDED FITTINGS.

This task covers:

- a. Removal
- b. Repair
- c. Replacement

INITIAL SETUP:

Tools

Tool kit, general mechanic's,  
5180-00-699-5273  
Torch outfit, cutting and  
welding medium duty, oxygen  
and acetylene, 3433-00-35,7-8116  
Tool kit, welder, 5180-00-754.-0661

Materials/Parts

Piping system, fuel transfer pump  
unit assembly P/N 8541051,  
refer to TM 55-1905-223-24P  
Warning tags, Item 1, Appendix C  
Utility pail, Item 13, Appendix C

General Safety Instructions

WARNING

- Ensure system is tagged to prevent operation, during maintenance. Generated pressure could cause injury.
- Use extreme care when breaking system connections. Escaping pressure and/or fluids could cause injury.
- Clean up spills immediately. Spills create an unsafe working area.
- Exercise extreme caution, when working with flammables.

REMOVAL

Refer to paragraph 3-217 for procedures.



---

3-252. REPLACE/REPAIR PIPE HANGERS.

---

This task covers:

- a. Removal
  - b. Repair
  - c. Replacement
- 

INITIAL SETUP:

Tools

Tool kit, general mechanic's,  
5180-00-699-5273

Materials/Parts

Piping system, fuel transfer pump  
unit assembly P/N 8541051,  
refer to TM 55-1905-223-24P

REMOVAL

Refer to paragraph 3-223 for procedures.

**MAINTENANCE OF PIPING SYSTEM, SEWAGE AND PLUMBING**

**3-253. REPLACE/REPAIR WELDED VALVES.**

This task covers:

- a. Removal
- b. Repair
- c. Replacement

INITIAL SETUP:

Tools

Tool kit, general mechanic's,  
5180-00-699-5273  
Torch outfit, cutting and  
welding medium duty, oxygen  
and acetylene, 3433-00-357-8116  
Tool kit, welder, 5180-00-754-0661

Materials/Parts

Piping system, sewage and  
plumbing, P/N 8528023 refer  
to TM 55-1905-223-24P  
Warning tags, Item 1, Appendix C  
Utility pail, Item 13, Appendix C

Equipment Condition

At Ship Service Switchboard, set MISC  
MCHRY POWER PANEL circuit breaker  
to OFF position. At Marine  
Sanitation control module set  
main circuit breaker to OFF position.  
Tag switches "Out of Service-Do  
Not Operate."  
All commodes tagged "Out of Service-  
Do Not Operate."

General Safety Instructions

Ensure system is turned OFF and  
tagged to prevent operation during  
maintenance. Generated pressure  
could cause injury.

WARNING

- Toxic and flammable vapors are generated in the sewage system. Provide ventilation from outside source before removing valves, covers, drain plugs, hoses, and fittings. Avoid open flames and prolonged breathing of fumes.
- Use extreme care when breaking system connections. Escaping pressure and/or fluids could cause injury.
- Clean up spills immediately with disinfectant. Spills create an unsafe working area.
- After contact with sewage contaminated equipment, clean yourself with disinfectant soap before performing hand-to-mouth functions such as eating, drinking, smoking, etc.

**REMOVAL**

Refer to paragraph 3-228 for procedures.

3-254. REPLACE/REPAIR WELDED FITTINGS.

This task covers:

- a. Removal
- b. Repair
- c. Replacement

INITIAL SETUP:

Tools

Tool kit, general mechanic's,  
5180-00-699-5273  
Torch outfit, cutting and  
welding medium duty, oxygen  
and acetylene, 3433-00-357-8116  
Tool kit, welder, 5180-00-754-0661

Materials/Parts

Piping system, sewage and  
plumbing, P/N 8528023 refer  
to TM 55-1905-223-24P  
Warning tags, Item 1, Appendix C  
Utility pail, Item 13, Appendix C

Equipment Condition

At Ship Service Switchboard, set MISC  
MCHRY POWER PANEL circuit breaker  
to OFF position. At Marine  
Sanitation control module set  
main circuit breaker to OFF position.  
Tag switches "Out of Service-Do Not  
Operate."  
All commodes tagged "Out of Service -  
Do Not Operate."

General Safety Instructions

Ensure system is turned OFF and  
tagged to prevent operation during  
maintenance. Generated pressure  
could cause injury.

WARNING

- Toxic and flammable vapors are generated in the sewage system. Provide ventilation from outside source before removing valves, covers, drain plugs, hoses, and fittings. Avoid open flames and prolonged breathing of fumes.
- Use extreme care when breaking system connections. Escaping pressure and/or fluids could cause injury.
- Clean up spills immediately with disinfectant. Spills create an unsafe working area.
- After contact with sewage contaminated equipment, clean yourself with disinfectant soap before performing hand-to-mouth functions such as eating, drinking, smoking, etc.

REMOVAL

Refer to paragraph 3-217 for procedures.

MAINTENANCE OF PIPING SYSTEM, BOWTHRUSTER
---

---

### 3-255. REPLACE/REPAIR WELDED VALVES.

---

This task covers:

- a. Removal
  - b. Repair
  - c. Replacement
- 

#### INITIAL SETUP:

##### Tools

Tool kit, general mechanic's,  
5180-00-699-5273  
Torch outfit, cutting and  
welding medium duty, oxygen  
and acetylene, 3433-00-357-8116  
Tool kit, welder, 5180-00-754-0661

##### Materials/Parts

Piping system, bowthruster  
P/N 8561034, refer to  
TM 55-1905-223-24P  
Warning tags, Item 1, Appendix C  
Utility pail, Item 13, Appendix C

##### Equipment Condition

At Ship Service Switchboard, set FWD  
DECK MCHRY MCC circuit breaker to  
OFF position. Tag switch "Out of  
Service- Do Not Operate."

##### General Safety Instructions

##### WARNING

- Ensure system is tagged to prevent operation during maintenance. Generated pressure could cause injury.
  - Use extreme care when breaking system connections. Escaping pressure and/or fluids could cause injury.
  - Clean up spills immediately. Spills create an unsafe working area.
  - Exercise extreme caution when working with flammables.
- 

#### REMOVAL

Refer to paragraph 3-228 for procedures.

3-256. REPLACE/REPAIR WELDED FITTINGS.

This task covers:

- a. Removal
- b. Repair
- c. Replacement

INITIAL SETUP:

Tools

Tool kit, general mechanic's,  
5180-00-699-5273  
Torch outfit, cutting and  
welding medium duty, oxygen  
and acetylene, 3433-00-357-8116  
Tool kit, welder, 5180-00-754-0661

Materials/Parts

Piping system, bowthruster  
P/N 8561034, refer to  
TM 55-1905-223-24P  
Warning tags, Item 1, Appendix C  
Utility pail, Item 13, Appendix C

Equipment Condition

At Ship Service Switchboard, set FWD  
DECK MCHRY MCC circuit breaker to  
OFF position. Tag switch "Out of  
Service-Do Not Operate."

General Safety Instructions

WARNING

- Ensure system is tagged to prevent operation during maintenance. Generated pressure could cause injury.
- Use extreme care when breaking system connections. Escaping pressure and/or fluids could cause injury.
- Clean up spills immediately. Spills create an unsafe working area.
- Exercise extreme caution when working with flammables.

REMOVAL

Refer to paragraph 3-217 for procedures.

---

3-257. REPLACE/REPAIR PIPE HANGERS.

---

This task covers:

- a. Removal
  - b. Repair
  - c. Replacement
- 

INITIAL SETUP:

Tools

Tool kit, general mechanic's,  
5180-00-699-5273

Materials/Parts

Piping system, bowthruster  
P/N 8561034, refer to  
TM 55-1905-223-24P

REMOVAL

Refer to paragraph 3-223 for procedures.

MAINTENANCE OF PIPING SYSTEM, STEERING GEAR
---

---

## 3-258. REPLACE/REPAIR WELDED FITTINGS.

This task covers:

- a. Removal
  - b. Repair
  - c. Replacement
- 

INITIAL SETUP:Tools

Tool kit, general mechanic's,  
5180-00-699-5273  
Torch outfit, cutting and  
welding medium duty, oxygen  
and acetylene, 3433-00-357-8116  
Tool kit, welder, 5180-00-754-0661

Materials/Parts

Piping system, steering gear  
P/N 8562035 refer to  
TM 55-1905-223-24P  
Warning tags, Item 1, Appendix C  
Utility pail, Item 13, Appendix C

Equipment Condition

At the Steering Gear Motor  
Controller, set main power  
switch to the OFF position.  
Tag switch "Out of Service-Do Not  
Operate."

General Safety InstructionsWARNING

- Ensure system is tagged to prevent operation during maintenance. Generated pressure could cause injury.
  - Use extreme care when breaking system connections. Escaping pressure and/or fluids could cause injury.
  - Clean up spills immediately. Spills create an unsafe working area.
  - Exercise extreme caution when working with flammables.
- 

## REMOVAL

Refer to paragraph 3-217 for procedures.

MAINTENANCE OF PIPING SYSTEM, EMERGENCY GENERATOR
---

---

## 3-259. REPLACE/REPAIR WELDED VALVES.

This task covers:

- a. Removal
  - b. Repair
  - c. Replacement
- 

INITIAL SETUP:Tools

Tool kit, general mechanic's,  
5180-00-699-5273  
Torch outfit, cutting and  
welding medium duty, oxygen  
and acetylene, 3433-00-357-8116  
Tool kit, welder, 5180-00-754-0661

Materials/Parts

Piping system, emergency  
generator P/N 8310013,  
refer to TM 55-1905-223-24P  
Warning tags, Item 1, Appendix C  
Utility pail, Item 13, Appendix C

Equipment Condition

At Emergency Switchboard, set  
EMERGENCY GENERATOR CIRCUIT  
BREAKER to the OFF position.  
Tag switch "Out of Service-Do Not  
Operate."

General Safety InstructionsWARNING

- Ensure system is tagged to prevent operation during maintenance. Generated pressure could cause injury.
  - Use extreme care when breaking system connections. Escaping pressure and/or fluids could cause injury.
  - Clean up spills immediately. Spills create an unsafe working area.
  - Exercise extreme caution when working with flammables.
- 

## REMOVAL

Refer to paragraph 3-228 for procedures.



3-260. REPLACE/REPAIR WELDED FITTINGS.

This task covers:

- a. Removal
- b. Repair
- c. Replacement

INITIAL SETUP:

Tools

Tool kit, general mechanic's,  
5180-00-699-5273  
Torch outfit, cutting and  
welding medium duty, oxygen  
and acetylene, 3433-00-357-8116  
Tool kit, welder, 5180-00-754-0661

Materials/Parts

Piping system, emergency  
generator P/N 8210013,  
refer to TM 55-1905-223-24P  
Warning tags, Item 1, Appendix C  
Utility pail, Item 13, Appendix C

Equipment Condition

At Emergency Switchboard, set  
EMERGENCY GENERATOR CIRCUIT  
BREAKER to the OFF position.  
Tag switch "Out of Service-Do Not  
Operate."

General Safety Instructions

WARNING

- Ensure system is tagged to prevent operation during maintenance. Generated pressure could cause injury.
- Use extreme care when breaking system connections. Escaping pressure and/or fluids could cause injury.
- Clean up spills immediately. Spills create an unsafe working area.
- Exercise extreme caution when working with flammables.

REMOVAL

Refer to paragraph 3-217 for procedures.

---

3-261. REPLACE/REPAIR PIPE HANGERS.

---

This task covers:

- a. Removal
  - b. Repair
  - c. Replacement
- 

INITIAL SETUP:

Tools

Tool kit, general mechanic's,  
5180-00-699-5273

Materials/Parts

Piping system, emergency  
generator P/N 8310013,  
refer to TM 55-1905-223-24P

REMOVAL

Refer to paragraph 3-222 for procedures.

MAINTENANCE OF PIPING SYSTEM, FOAM PROPORTIONERS
--

---

## 3-262. REPLACE/REPAIR WELDED FITTINGS.

This task covers:

- a. Removal
  - b. Repair
  - c. Replacement
- 

INITIAL SETUP:Tools

Tool kit, general mechanic's,  
5180-00-699-5273  
Torch outfit, cutting and  
welding medium duty, oxygen  
and acetylene, 3433-00-357-8116  
Tool kit, welder, 5180-00-754-0661

Materials/Parts

Piping system, foam proportioners  
P/N 8529048, refer to  
TM 55-1905-223-24P  
Warning tags, Item 1, Appendix C  
Utility pail, Item 13, Appendix C

Equipment Condition

At Ship Service Switchboard, set FIRE  
PUMP 1 and FIRE PUMP 2 circuit  
breakers to the OFF position. Tag  
switch "Out of Service-Do Not  
Operate."

General Safety InstructionsWARNING

- Ensure system is tagged to prevent operation during maintenance. Generated pressure could cause injury.
  - Use extreme care when breaking system connections. Escaping pressure and/or fluids could cause injury.
  - Clean up spills immediately. Spills create an unsafe working area.
  - Exercise extreme caution when working with flammables.
- 

## REMOVAL

Refer to paragraph 3-217 for procedures.

---

3-263. REPLACE/REPAIR PIPE HANGERS.

---

This task covers:

- a. Removal
  - b. Repair
  - c. Replacement
- 

INITIAL SETUP:

Tools

Tool kit, general mechanic's,  
5180-00-699-5273

Materials/Parts

Piping system, foam proportioners  
P/N 8529048, refer to  
TM 55-1905-223-24P

---

REMOVAL

Refer to paragraph 3-223 for procedures.

MAINTENANCE OF PIPING SYSTEM, FIRE PUMP UNIT ASSEMBLY
---

---

### 3-264. REPLACE/REPAIR WELDED FITTINGS.

---

This task covers:

- a. Removal
  - b. Repair
  - c. Replacement
- 

#### INITIAL SETUP:

##### Tools

Tool kit, general mechanic's,  
5180-00-699-5273  
Torch outfit, cutting and  
welding medium duty, oxygen  
and acetylene, 3433-00-357-8116  
Tool kit, welder, 5180-00-754-0661

##### Materials/Parts

Piping system, fire pump unit  
assembly P/N 8529047, refer  
to TM 55-1905-223-24P  
Warning tags, Item 1, Appendix C  
Utility pail, Item 13, Appendix C

##### Equipment Condition

At Ship Service Switchboard, set FIRE  
PUMP 1 and FIRE PUMP 2 circuit  
breakers to the OFF position. Tag  
switch "Out of Service-Do Not  
Operate."

##### General Safety Instructions

##### WARNING

- Ensure system is tagged to prevent operation during maintenance. Generated pressure could cause injury.
  - Use extreme care when breaking system connections. Escaping pressure and/or fluids could cause injury.
  - Clean up spills immediately. Spills create an unsafe working area.
  - Exercise extreme caution when working with flammables.
- 

#### REMOVAL

Refer to paragraph 3-217 for procedures.

---

3-265. REPLACE/REPAIR PIPE HANGERS.

---

This task covers:

- a. Removal
  - b. Repair
  - c. Replacement
- 

INITIAL SETUP:

Tools

Tool kit, general mechanic's,  
5180-00-699-5273

Materials/Parts

Piping system, fire pump unit  
assembly P/N 8529047, refer  
to TM 55-1905-223-24P

---

REMOVAL

Refer to paragraph 3-223 for procedures.

**HULLS/MISCELLANEOUS****3-266. REPLACE/REPAIR EMERGENCY DIESEL GENERATOR DAY TANK. (Figure 3-213).****This task covers:**

- a. Removal
- b. Repair
- c. Replacement

**INITIAL SETUP:**Tools

Tool kit, general mechanic's,  
5180-00-699-5273  
Tool kit, welder's,  
5180-00-754-0661  
Torch outfit, cutting and  
and welding medium duty,  
oxygen and acetylene,  
3433-00-357-8116

Equipment Condition

Fuel supply and fill valves to day tank  
closed.  
Drain valve open to drain day tank,  
(TM 55-1905-223-10).  
Liquid quantity indicator removed,  
para. 2-273 .  
Welding procedures, TM 55-1900-204-24

Materials/Parts

Emergency diesel generator  
day tank P/N 03-6441-0000

**REMOVAL****WARNING**

Prior to entering or cutting away tank, ensure tank is free of gases by ventilating tank and washing out tank with soapy water.

- a. Remove plain hexagon nuts (3, 6, 9, 12, 17), lockwashers (2, 5, 8, 11, 16), and machine bolts (1, 4, 7, 10, 15).
- b. Remove hexagon nut (13) and lockwasher (14).
- c. Remove tank (18) from bulkhead.

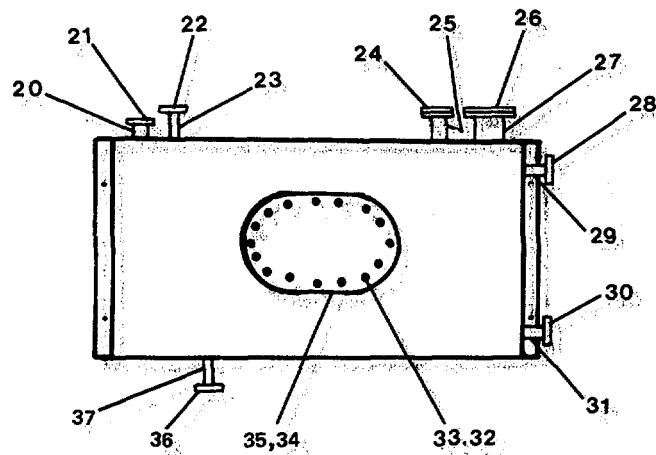
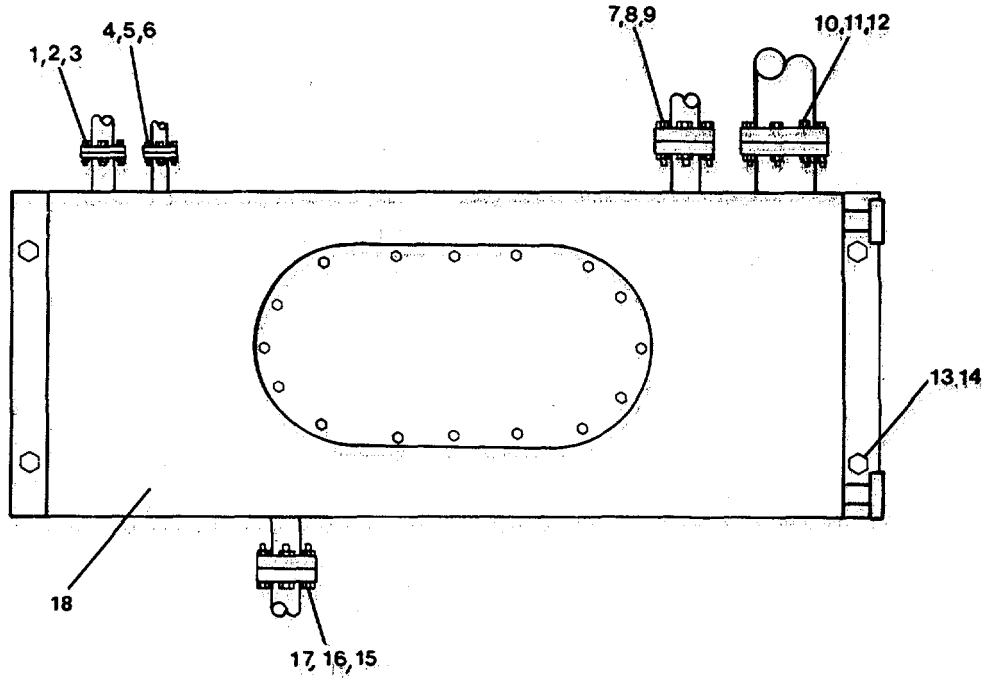

FIGURE 3-213. Replace/Repair Emergency Diesel Generator Day Tank.



## DISASSEMBLY

- a. Using a cutting torch, remove pipe flanges (21, 22, 24, 26, 28, 30, 36).
- b. Using a cutting torch, remove metallic pipes (20, 23, 25, 27, 29, 31, 37).
- c. Remove plain hexagon nuts (32) and lockwashers (33).
- d. Remove steel plate (34) and gasket material (35).

## REPAIR

Repair at this level of maintenance is by replacement of worn or defective parts.

## ASSEMBLY

- a. Install gasket material (35) and steel plate (34).
- b. Install lockwasher (33) and plain hexagon nuts (32).
- c. Using a welding torch, install metallic pipes (37, 31, 29, 27, 25, 23, 20).
- d. Using a welding torch, install pipe flanges (36, 30, 28, 26, 24, 22, 21).

## REPLACEMENT

- a. Install tank (18) on bulkhead.
- b. Install lockwasher (14) and hexagon nut (13).
- c. Install machine bolts (15, 10, 7, 4, 1) lockwashers (16, 11, 8, 5, 2) and plain hexagon nuts (17, 12, 9, 6, 3).
- d. Replace liquid quantity indicator, para. 2-292 .
- e. Open fuel supply and fill valves, TM 55-1905-223-10.

3-267. REPLACE/REPAIR BOWTHRUSTER DAY TANK. (Figure 3-214).

This task covers:

- |                |             |                |
|----------------|-------------|----------------|
| a. Removal     | c. Repair   | e. Replacement |
| b. Disassembly | d. Assembly |                |

INITIAL SETUP:

Tools

Tool kit, general mechanic's,  
5180-00-699-5273  
Tool kit, welder's  
5180-00-754-0661  
Torch outfit, cutting and welding  
medium duty, oxygen and acetylene,  
3433-00-357-8116

Equipment Condition

Fuel supply and fill valves to day tank  
closed.  
Drain valve open to drain day tank,  
TM 55-1905-223-10  
Liquid quantity indicator removed,  
para. 2-380 .  
Welding procedures, TM 55-1900-204-24.

Materials/Parts

Bowthruster engine day tank  
P/N 03-0241-2442

REMOVAL

WARNING

Prior to entering or cutting away tank, ensure tank is free of gases by ventilating tank and washing out tank with soapy water.

- a. Remove plain hexagon nuts (3, 6, 9, 15, Sheet 1 of 2), lockwashers (2, 5, 8, 14) and machine bolts (1, 4, 7, 13).
- b. Remove plain hexagon nuts (10) and lockwashers (11).
- c. Remove flat bar (12).
- d. Remove tank (16).

DISASSEMBLY

- a. Remove plain hexagon nut (21, Sheet 2 of 2), lockwashers (22), and machine bolt (23).
- b. Remove steel plate (19) and gasket material (20).

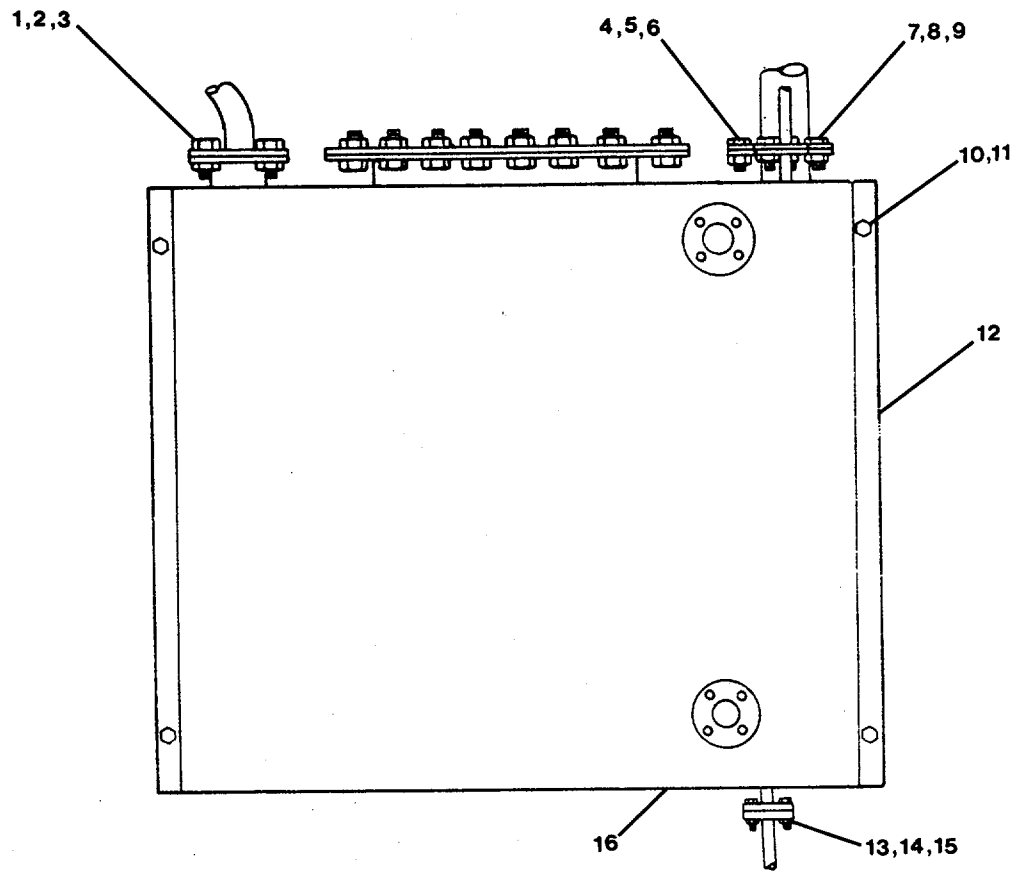

FIGURE 3-214. Replace/Repair Bowthruster Day Tank (Sheet 1 of 2).

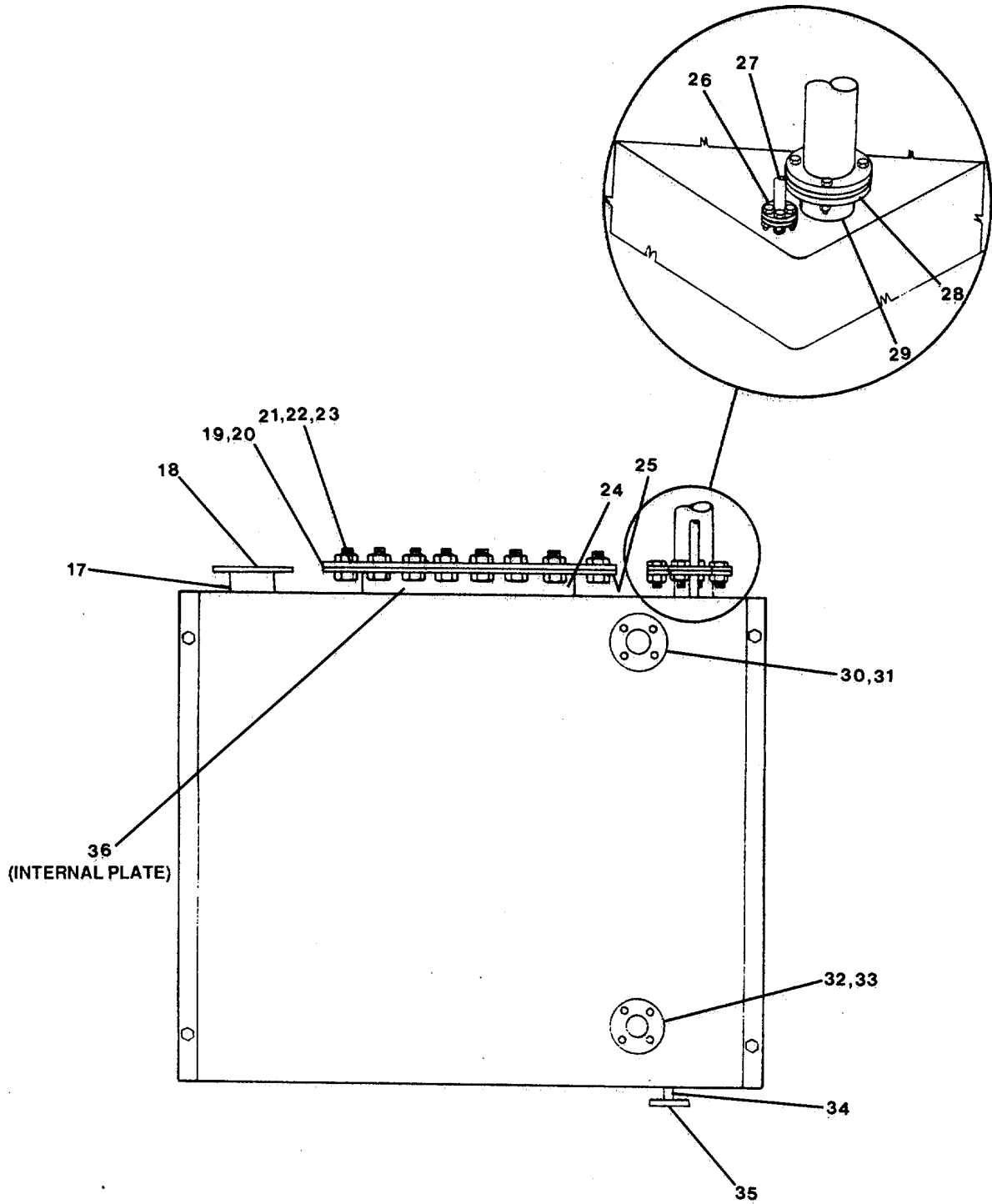

FIGURE 3-214. Replace/Repair Bowthruster Day Tank (Sheet 2 of 2).

- c. Using cutting torch, remove pipe flanges (18, 25, 26, 28, 30, 32, 35).
- d. Using cutting torch, remove metallic pipes (17, 24, 27, 29, 31, 33, 34).
- e. Remove flat bar (36).

#### REPAIR

Repair at this level of maintenance is by replacement of worn or defective parts.

#### ASSEMBLY

- a. Install flat bar (36).
- b. Using a welding torch, install metallic pipes (34, 33, 31, 29, 27, 24, 17).
- c. Using a machine torch, install pipe flanges (35, 32, 30, 28, 26, 25, 18).
- d. Install gasket material (20) and steel plate (19).
- e. Install machine bolt (23), lockwasher (22), and plain hexagon nut (21).

#### REPLACEMENT

- a. Install tank (16).
- b. Install flat bar (12).
- c. Install lockwashers (11) and plain hexagon nuts (10).
- d. Install machine bolts (13, 7, 4, 1), lockwashers (14, 8, 5, 2), and plain hexagon nuts (15, 9, 6, 3).
- e. Replace liquid quantity indicator, para. 2-293.
- f. Open fuel supply and fill valves, TM 55-1905-223-10.

3-268. REPLACE/REPAIR HYDRAULIC OIL STORAGE TANK. (Figure 3-215).

This task covers:

- |             |                |           |
|-------------|----------------|-----------|
| a. Removal  | b. Disassembly | c. Repair |
| d. Assembly | e. Replacement |           |

INITIAL SETUP:

Tools

Tool kit, general mechanic's,  
5180-00-699-5273  
Tool kit, welder's,  
5180-00-754-0661  
Torch outfit, cutting and  
welding medium, duty,  
oxygen and acetylene,  
3433-00-357-8116

Equipment Condition

Hydraulic oil storage tank liquid  
quantity indicator removed, para.  
2-381  
Handpump and piping removed, refer to  
hydraulic piping system.  
Welding procedures, TM 55-1900-204-24

Materials/Parts

Hydraulic oil storage tank  
P/N 03-6442-0000

REMOVAL

WARNING

Prior to entering or cutting away tank, ensure tank is free of gases by ventilating tank and washing out tank with soapy water.

Remove attaching hardware and hydraulic oil storage tank.

DISASSEMBLY

- a. Using a cutting torch remove pipe flanges (3, 4, 7).
  - b. Using a cutting torch remove metallic pipes (2, 5, 6).
  - c. Remove angle bar (1).

REPAIR

Repair at this level of maintenance is by replacement of worn or defective parts.

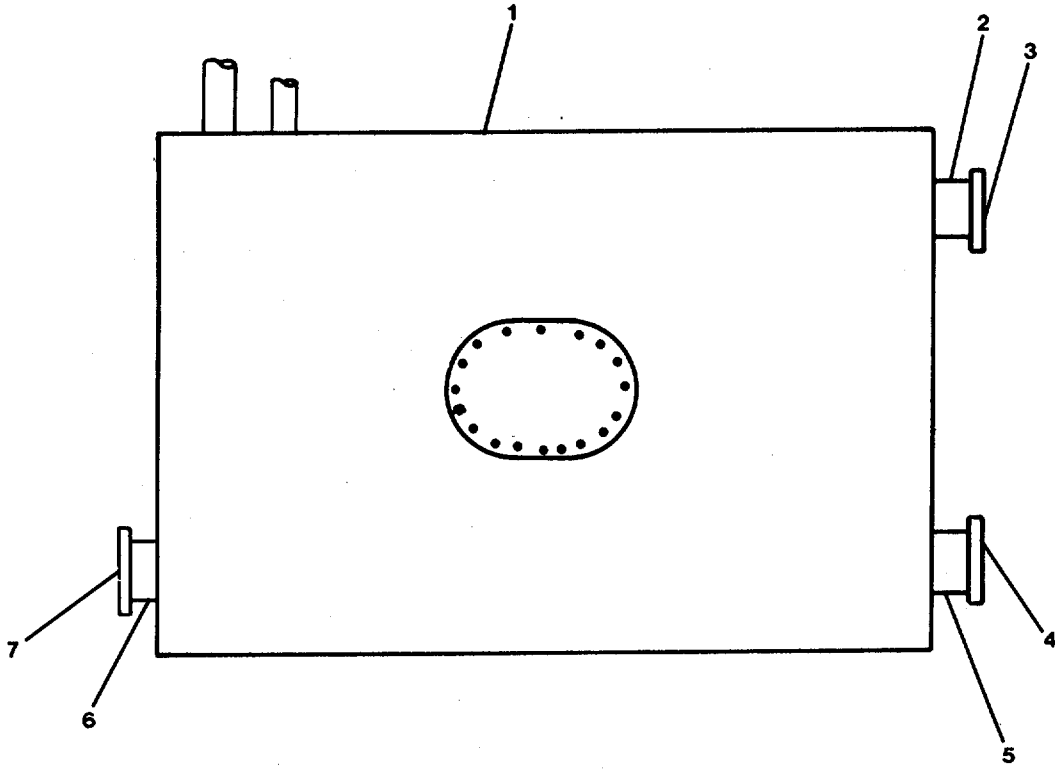

FIGURE 3-215. Hydraulic Oil Storage Tank.

ASSEMBLY

- a. Install angle bar (1).
- b. Using a welding torch, install metallic pipes (6, 5, 2).
- c. Using a welding torch, install pipe flanges (7, 4, 3).

REPLACEMENT

Replace hydraulic oil storage tank and attaching hardware.



**SECTION VI. Preparation for Storage for Shipment**

3-269. Refer to Section VI, Chapter 2.

**CHAPTER 4**

**INTERMEDIATE GENERAL SUPPORT MAINTENANCE INSTRUCTIONS**

	<u>Page</u>
SECTION I. Repair Parts, Special Tools; Test, Measurement, and Diagnostic Equipment (TMDE); and Support Equipment .....	4-1
SECTION II. Service Upon Receipt .....	4-1
SECTION III. Intermediate General Support Preventive Maintenance Checks and Services 4-2	
SECTION IV. Intermediate General Support Troubleshooting Procedures .....	4-2
SECTION V. Intermediate General Support Maintenance Procedures .....	4-4
SECTION VI. Preparation for Storage or Shipment .....	4-62

**SECTION I. REPAIR PARTS, SPECIAL TOOLS; TEST, MEASUREMENT, AND DIAGNOSTIC EQUIPMENT (TMDE); AND SUPPORT EQUIPMENT**

**4-1. Common Tools and Equipment.** For authorized common tools and equipment, refer to the Modified Table of Organization and Equipment (MTOE) applicable to your organization.

**4-2. Special Tools (TMDE), and Support Equipment.** For special tools, test, measurement, and diagnostic equipment; and support equipment, requirements are listed and illustrated in the Repair Parts and Special Tools List (RPSTL), TM 55-1905-223-24P. These items are also listed in the Maintenance Allocation Chart (MAC), Appendix B.

**4-3. Repair Parts.** Repair parts are listed and illustrated in the Repair Parts and Special Tools List (RPSTL), TM 55-1905-223-24P.

**SECTION II. SERVICE UPON RECEIPT**

**4-4. Checking Unpacked Equipment.**

- a. Inspect the equipment for damage incurred during shipment. If the equipment has been damaged, report the damage in accordance with the instructions of DA Pam 738-750.
- b. Check the equipment against the packing slip to see if the shipment is complete. Report all discrepancies in accordance with the instructions of DA Pam 738-750.
- c. Check to see whether the equipment has been modified.

- d. Remove protective caps, plugs, inserts, wrappings, and tape when inspection/inventory is completed. Inspect piping openings for damage. Wipe off dirt, grease, or protective films at time of installation.
- e. Remove chocks from resilient mounted components.

**4-5. Initial Setup Procedure.** Includes operational checks and inspection that are not performed for a routine startup. Direct support maintenance personnel will perform initial setup in accordance with the operator's manual, TM 55-1905-223-10.

**4-6. Normal Startup.** Refer to the operator's manual, TM 55-1905-223-10.

**4-7. Shutdown Procedure (Usual or Unusual).** Refer to the operator's manual, TM 55-1905-223-10.

**SECTION III. INTERMEDIATE GENERAL SUPPORT PREVENTIVE  
MAINTENANCE CHECKS AND SERVICES (PMCS)**

**4-8. PMCS.** There is no PMCS at the general support level. See Chapter 2, Section III.

**SECTION IV. INTERMEDIATE GENERAL SUPPORT TROUBLESHOOTING PROCEDURES**

**4-9. Symptom Index.** Both a symptom index and a troubleshooting table are provided. This symptom index will help you locate the information you need for troubleshooting.

SYMPTOM INDEX		Troubleshooting Procedure Table 4-1
<b>PROPELLERS AND SHAFTS</b>		
Bent shafting		Item 2
Erratic vibration, not attributed to shaft rpm or propeller blade frequency		Item 4
Objectionable shaft vibration		Item 1
Stern tube hot to touch		Item 3

**4-10. Troubleshooting.** Table 4-1 lists the common fault conditions that may be found during operation or maintenance of the equipment. Look for causes and do corrective actions in the order listed. This manual cannot list every symptom that may show up, and it cannot list all the possible causes and corrective actions. If a symptom is not listed, or if it keeps up after you have performed the corrective actions, notify your supervisor.

Table 4-2. Troubleshooting

MALFUNCTION	TEST OR INSPECTION	CORRECTIVE ACTION
-------------	--------------------	-------------------

**Propeller Shaft Assembly**

1. Objectionable shaft vibration.

STEP 1. After shaft assembly is removed, check for straightness according to construction drawings.  
Replace shaft. Refer to paragraph 4-23 .

2. Bent shafting.

STEP 1. Inspect shaft assembly in vessel for any bends.  
Replace shaft assembly. Refer to paragraph 4-23 .

STEP 2. Inspect shaft assembly under water for any bends.  
Replace shaft assembly. Refer to paragraph 4-23 .

3. Stern tube hot to touch with hand.

STEP 1. Check to see that S.W. valve 13 or 14 is open and thin stream of water is trickling past stuffing box gland.  
Replace stern tube bearing. Refer to paragraph 4-23 .

4. Erratic vibrations, not attributed to shaft rpm or propeller blade frequency.

STEP 1. Require diver inspection of propellers, cone nut and glands, for damage or bent propeller blades.  
Replace propeller. Depot maintenance in shipyard drydock facility required. Replace propeller hub gland packing. Refer to paragraph 4-23 .

**SECTION V. INTERMEDIATE GENERAL SUPPORT MAINTENANCE PROCEDURES**

**4-11. Detailed Procedures.** Information to perform intermediate general support maintenance tasks, in accordance with the Maintenance Allocation Charts (MACs), is provided. The procedures for each separate MAC begin with a boxed heading showing.

MAINTENANCE OF ...

**MAINTENANCE OF PURIFIERS/SEPARATORS**
**4-12. Repair Electric Motor Assembly. (Figure 4-1)**
**This task covers:**
**a. Disassembly**
**b. Repair**
**c. Assembly**
**INITIAL SETUP:**
Tools

Tool kit, general mechanic's,  
5180-00-699-5273  
Bearing puller P/N ST-1249  
Arbor press, 4920-00-373-9376

Equipment Condition

Motor and clutch removed as specified  
in paragraph 2-17 .

Materials/Parts

Resilient ring P/N 1.58  
Contact roller bearing P/N 1.60  
Gasket P/N 5.83  
Gasket P/N 5.03  
Retaining ring P/N 7.12  
Feather key P/N 3.88  
Contact roller bearing P/N 6.10  
Rotor P/N 3.00  
Stator P/N 4.00

**DISASSEMBLY**

- a. Remove four machine screws (7) from terminal box cover (6).
- b. Remove cover (6) and gasket (5).
- c. Remove screw (8), lockwasher (9) and terminal clips (10, 11).
- d. Remove two screws (4).
- e. Separate terminal board (3) from terminal box (1) and link (15). Remove terminal board.
- f. Remove four machine screws (2).
- g. Remove terminal box.
- h. Remove plug (13) and gasket (12) from terminal box.

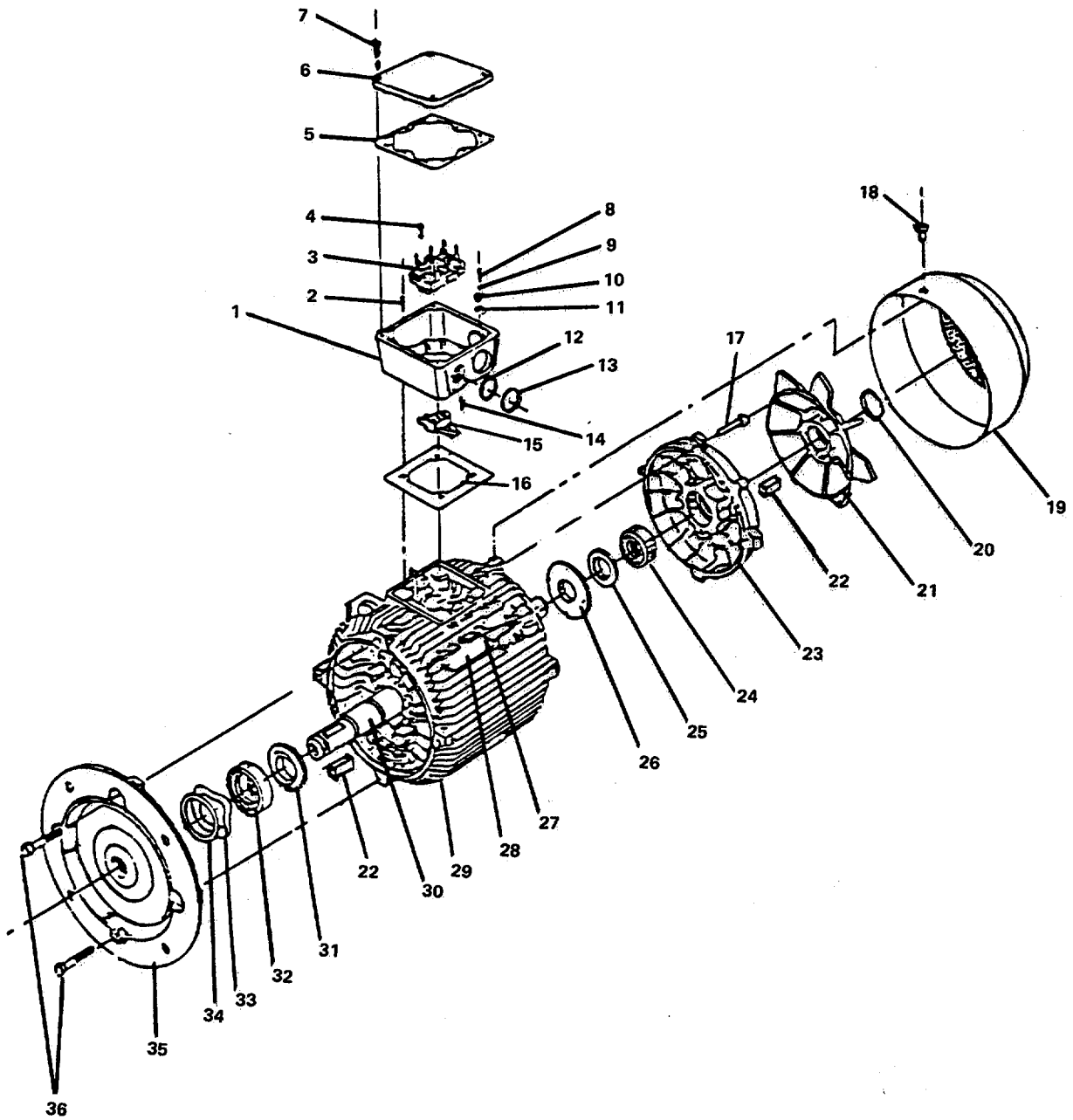

FIGURE 4-1. Electric Motor Assembly.

- i. Remove screw (14).
- j. Remove link (15).
- k. Remove gasket (16).
- l. Remove screw (18) and fan cowl (19).
- m. Remove retaining ring (20) and external fan (21).
- n. Remove feather key (22).
- o. Remove four screws (17) and end shield (23).
- p. Use bearing puller to remove contact roller bearing (24).
- q. Remove cox ring (25) and inner bearing cap (26).
- r. Remove feather key (22).
- s. Remove four machine screws (36).
- t. Remove end shield (35).
- u. Remove equalizing ring (34) and resilient ring (33).
- v. Remove rotor (30) from stator (29).
- w. Use bearing puller to remove contact roller bearing (32).
- x. Remove cox ring (31).

## REPAIR

Repair of motor assembly is by replacing resilient ring (33), contact roller bearing (24), gasket (5, 16), retaining ring (20), feather keys (22), contact roller bearing (32), rotor (30), stator (29).

### NOTE

Refer to LO 55-1905-223-12 for motor lubrication procedures.

## ASSEMBLY

- a. Install cox ring (31) and rotor (30).
- b. Use arbor press to install contact roller bearing (32) on rotor.
- c. Install rotor (30) in stator (29).
- d. Install resilient ring (33) and equalizing ring (34).
- e. Install end shield (35).



- f. Install four machine screws (36).
- g. Install feather key (22).
- h. Install inner bearing cap (26) and cox ring (25) on rotor (30).
- i. Use arbor press to install contact roller bearing (24) on rotor.
- j. Install end shield (23) and four screws (17).
- k. Install feather key (22).
- l. Install external fan (21) and retaining ring (20).
- m. Install fan cowl (19) and screw (18).
- n. Install gasket (16).
- o. Install link (15).
- p. Install screw (14) and secure link to motor.
- q. Install gasket (15) and plug (13) on terminal box (1).
- r. Install terminal box.
- s. Install four machine screws (2).
- t. Install terminal board (3) in terminal box (1) and attach to link (15). Secure to terminal box with two screws (4).
- u. Install terminal clips (11, 10), lockwasher (9) and secure with screw (8).
- v. Install gasket (5) and cover (6).
- w. Install four machine screws (7) and secure cover to terminal box.
- x. Motor and clutch replaced as specified in paragraph 2-17 .

**4-13. Repair Bowl Assembly. (Figure 4-2)**

**This task covers:**

- a. Disassembly**
**b. Repair**
**c. Assembly**

**INITIAL SETUP:**

Tools

Tool kit, general mechanic's,  
5180-00-699-5273  
Hook wrench  
P/N 0003-3667-000(80871)  
Annular wrench  
P/N 0003-3987-000(80871)

Equipment Condition

Hood assembly removed as specified in paragraph 2-20 .

Materials/Parts

Gasket P/N 0007-1989-750  
Preformed packing P/N 0007-2942-750  
Regulating ring P/N 2125-6691-000  
Warning tag, Item 1, Appendix C

**DISASSEMBLY**

- a. Release brake by turning handle (1) clockwise until bowl assembly can be rotated by hand.
- b. Turn two bowl lock screws (2) until they fit into recesses in bowl bottom (one recess is located below "O" mark on bowl bottom) do not apply pressure to lock screws. It may be necessary to rotate bowl assembly by hand to align recesses with lock screws.

**CAUTION**

Both lock ring (6) and (7) are left hand thread.

- c. Unscrew lock ring (6) by tapping on handle of hook wrench in clockwise direction. (Left hand thread).
- d. Remove lock ring, regulating ring (5) and gasket (4) from bowl top (8).
- e. Unscrew lock ring (7) by tapping on handle of annular wrench in clockwise direction. (Left hand thread).
- f. Remove lock ring from bowl bottom (3).
- g. Remove bowl top and preformed packing (9) for distributor (10).

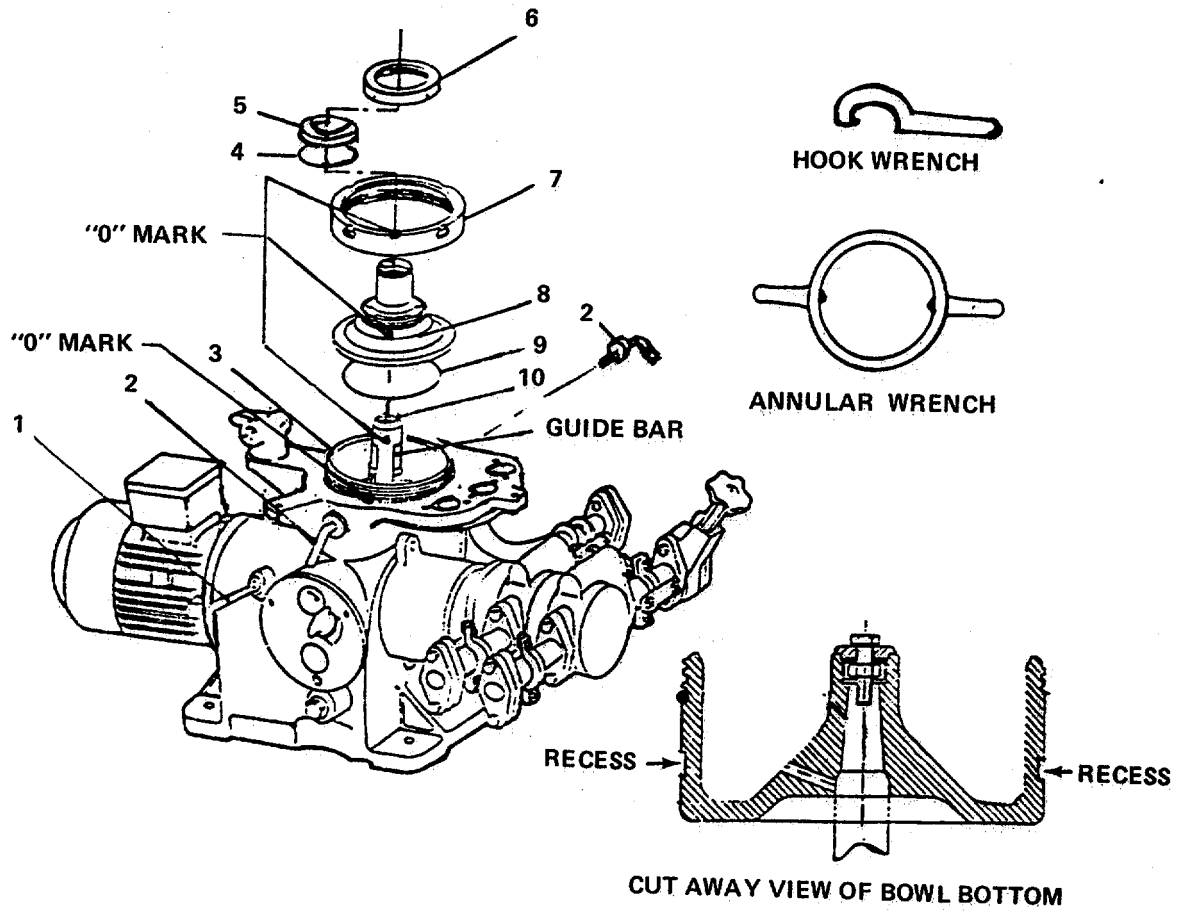

FIGURE 4-2. Bowl (Top) Assembly.

## REPAIR

Repair of bowl assembly consists of replacing regulating ring (5), gasket (4), preformed packing (9).

## ASSEMBLY

- a. Lubricate bowl lock rings (6, 7) and threads of bowl top (8) and bowl bottom (3). Refer to LO 55-1905-223-12.
- b. Install preformed packing (9) on bowl bottom (3).
- c. Install bowl top on distributor with "O" marks on distributor and bowl top aligned with "O" mark on bowl bottom. Make sure that guide bars of the distributor catches into the grooves of bowl tap.

### CAUTION

Both lock ring (7) and (6) are left hand thread.

- d. Install lock ring (7) on threads of bowl bottom by hand in counterclockwise direction then tighten it with annular wrench. (Left hand thread). Tap against the wrench handle until the "O" marks on lock ring and bowl top (8) are aligned. Do not slip a pipe over wrench handle to obtain leverage.
- e. Install gasket (4) and regulating ring (5) on bowl top.
- f. Install lock ring (6) on threads of bowl top by hand in counterclockwise direction then tighten it with hook wrench. (Left hand thread). Tap against wrench handle until a slight resistance is felt. Do not over tighten lock ring.
- g. Loosen bowl lock screws (2) until bowl assembly can be turned by hand.
- h. Set brake by turning handle (1) counterclockwise.
- i. Replace hood assembly as specified in paragraph 2-20 .

**4-14. Repair Vertical Gear Assembly. (Figure 4-3)**

**This task covers:**

- a. Disassembly**
**b. Repair**
**c. Assembly**

**INITIAL SETUP:**

Tools

Tool kit, general mechanic's,  
5180-00-699-5273

Equipment Condition

Vertical gear removed as specified in  
paragraph 3-17 .

Materials/Parts

Preformed packing P/N 0007-1988-750  
 Bushing P/N 0008-2533-000  
 Grooved ball bearing P/N 0011-6205-110  
 Worm spindle P/N 2125-3420-010  
 Gasket P/N 0007-2485-750  
 Cylindrical spring P/N 0006-4271-160  
 Spherical plain bearing  
     P/N 0011-8065-000  
 Annular ball bearing P/N 0011-3203-470

**DISASSEMBLY**

Refer to removal procedures in paragraph 3-17 .

**REPAIR**

Repair of vertical gear assembly consists of replacing preformed packing (5), bushing (7), grooved ball bearing (9), worm spindle (10), gasket (16), cylindrical spring (17), spherical plain bearing (19), annular ball bearing (12).

**ASSEMBLY**

Refer to replacement procedures in paragraph 3-17 .

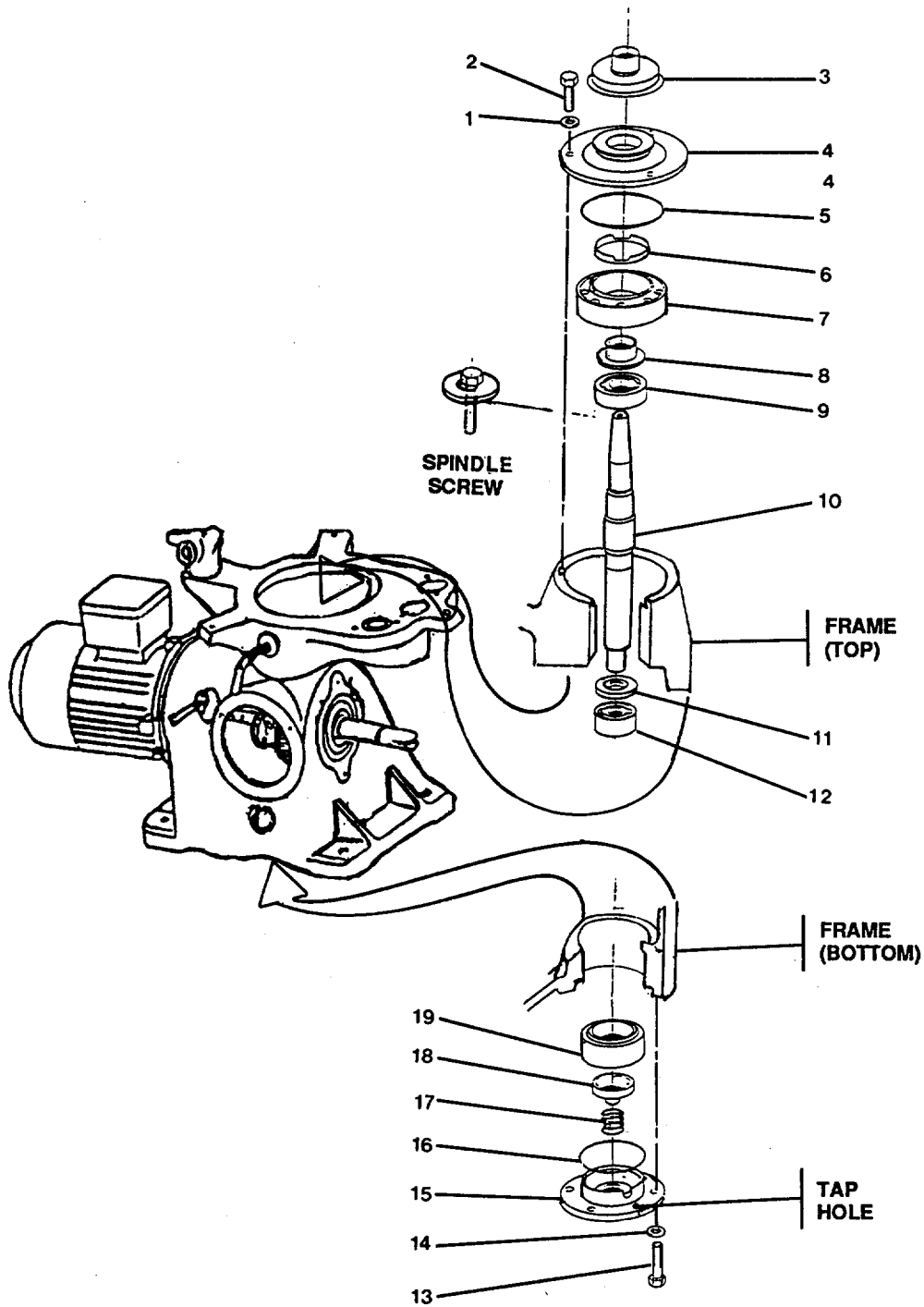

FIGURE 4-3. Vertical Gear Assembly.

**4-15. Repair Horizontal Gear Assembly. (Figure 4-4)**

**This task covers:**

- a. **Disassembly**                      b. **Repair**                      c. **Assembly**

**INITIAL SETUP :**

Tools

Tool kit, general mechanic's,  
5180-00-699-5273

Equipment Condition

Shut down - TM 55-1905-223-10  
Horizontal gear removed as specified in  
paragraph'3-18 .

Materials/Parts

Gasket P/N 0004-5197-770,  
P/N 0004-2463-770  
Retaining ring P/N 0026-5854-170  
Grooved ball bearing P/N 0011-6202-000,  
0011-6204-000  
Worm wheel assembly P/N 2125-3449-010

**DISASSEMBLY**

Refer to removal procedures in paragraph 3-18 .

**REPAIR**

Repair of horizontal gear assembly consists of replacing gasket (19), (11), retaining ring (17), grooved ball bearing (12, 16), worm wheel assembly (24).

**ASSEMBLY**

Refer to replacement procedures in paragraph 3-18 .

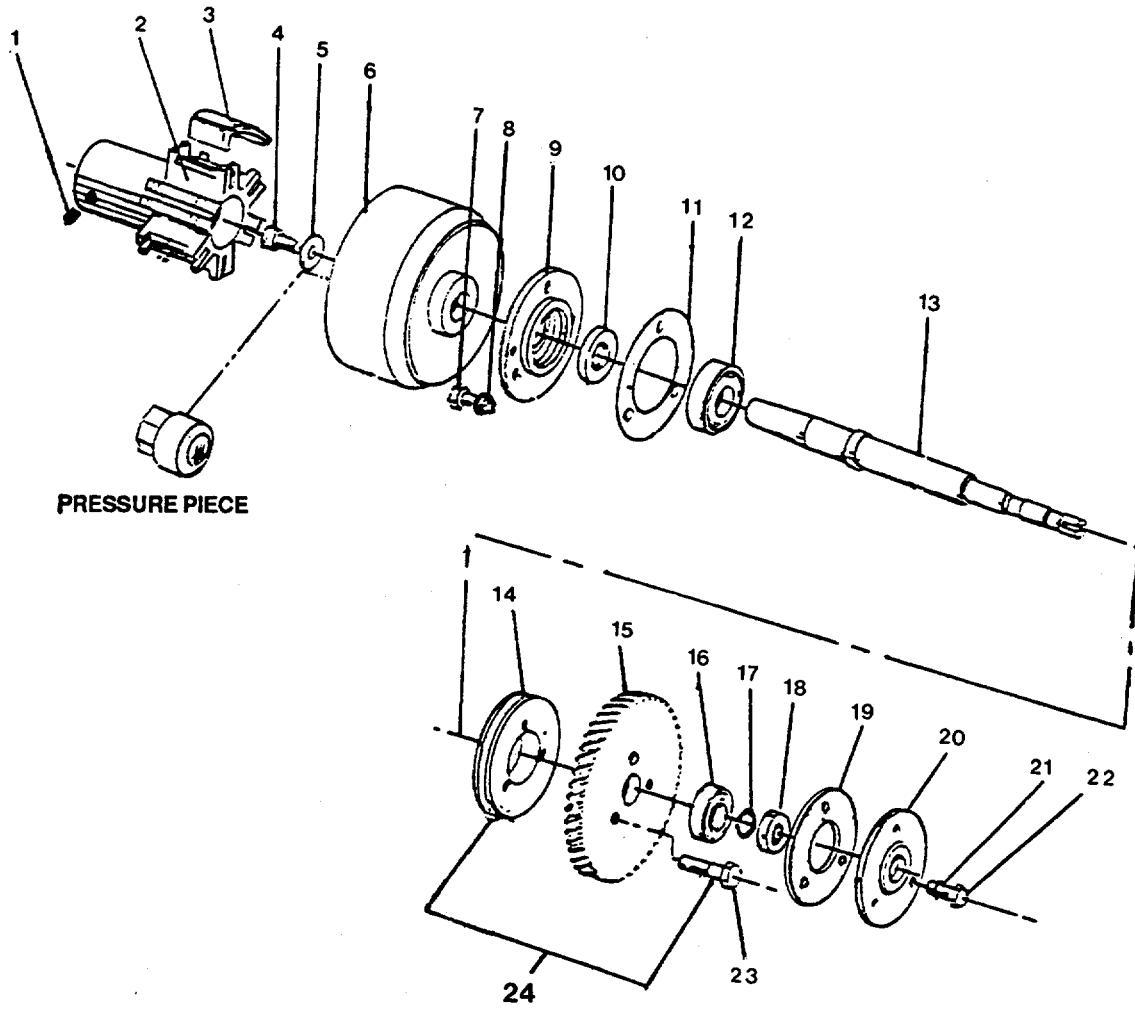

FIGURE 4-4. Horizontal Gear Assembly.



**4-16. Replace/Repair Frame Assembly.**

**This task covers:**

- |             |                |           |
|-------------|----------------|-----------|
| a. Removal  | b. Disassembly | c. Repair |
| d. Assembly | e. Replacement |           |

**INITIAL SETUP :**

Tools

Tool kit, general mechanic's,  
5180-00-699-5273

Equipment Condition

Electrical power to lube oil purifier  
turned OFF at P205 power/lighting  
panel and tagged "Out of Service - Do  
Not Operate."

Materials/Parts

Frame P/N 2125-1001-000  
Rubber cushion P/N 0021-3017-750  
Gasket P/N 0004-5447-740(3)  
Gasket P/N 0018-4841-750  
Gasket P/N 0007-2387-750  
Gasket P/N 0004-2076-700  
Preformed packing P/N 0007-2508-750  
Sight glass P/N 0001-0040-820  
Warning tag, Item 1, Appendix C  
Porcelain cement/two-component  
adhesive, Item 19, Appendix C

**REMOVAL**

- a. Remove hood assembly as specified in paragraph 2-20 .
- b. Remove pump connection assembly as specified in paragraph 2-18 .
- c. Remove double gear pump assembly as specified in paragraph 2-19 .
- d. Remove motor assembly as specified in paragraph 2-17 .
- e. Remove bowl assembly as specified in paragraph 3-16 .
- f. Remove horizontal gear assembly as specified in paragraph 3-18 .
- g. Remove vertical gear assembly as specified in paragraph 3-17 .

**DISASSEMBLY (Figure 4-5)**

- a. Gaskets.
  - (1) Remove three gaskets (1) from frame top.

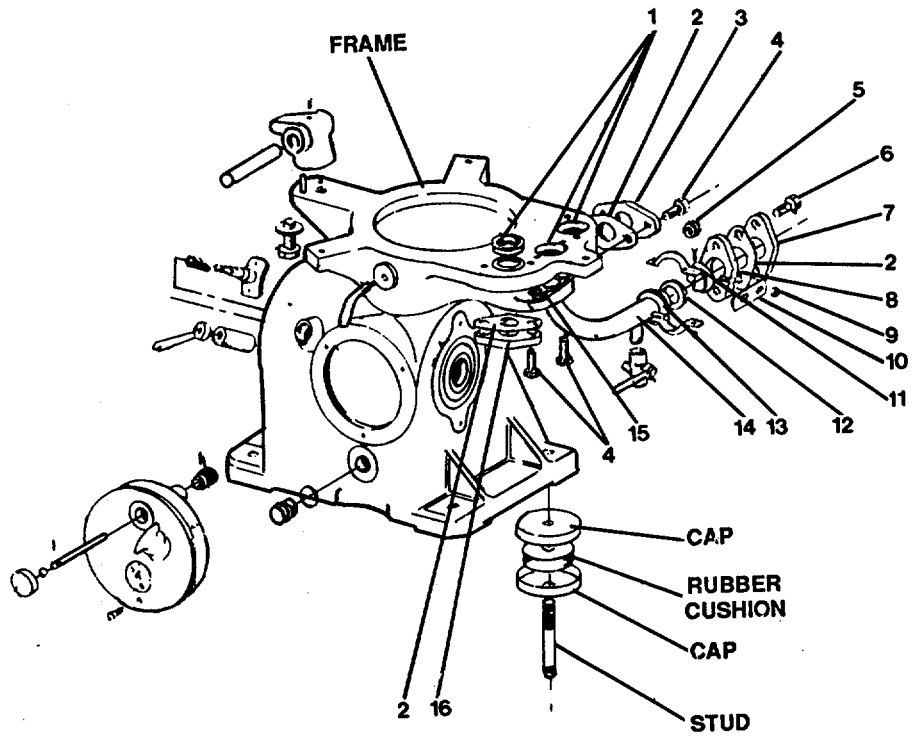

FIGURE 4-5. Purifier Frame Piping.

- (2) Remove two machine screws (4) from side of frame.
- (3) Remove flange (3) and gasket (2).
- (4) Remove two plain hex nuts (5) and machine screws (6) from expansion joint (8).
- (5) Separate flange (7) and gasket (2) from expansion joint.
- (6) Remove clamp assembly (11).
- (7) Remove two plain hex nuts (9) securing plate (10) to manifold (14).
- (8) Remove plate (10).
- (9) Separate flange (7), gasket (2) and expansion joint (8) from gasket (12), gasket retainer (13) and manifold (14).
- (10) Remove two machine screws (4) from manifold flange on lower ledge of frame.
- (11) Remove manifold (14) and gasket (15).
- (12) Remove two machine screws (4) from flange (16) on underside of frame.
- (13) Remove flange and gasket (2).

b. Rubber Cushions.

**NOTE**

Refer to paragraph 3-17, vertical gear assembly for disassembly procedures of rubber cushions and caps.

- (1) Caps.
- (2) Rubber cushions.

**NOTE**

Refer to Figure 4-6 for remaining removal procedures.

c. Revolution Indicator Housing.

- (1) Remove oil drain screw (11), gasket (10) and drain oil.
- (2) Remove three machine screws (18) and separate revolution housing (15) from frame.
- (3) Remove gasket (14) from revolution housing.
- (4) Remove cylindrical notched pin (12) and separate worm wheel (13) from shaft (20).

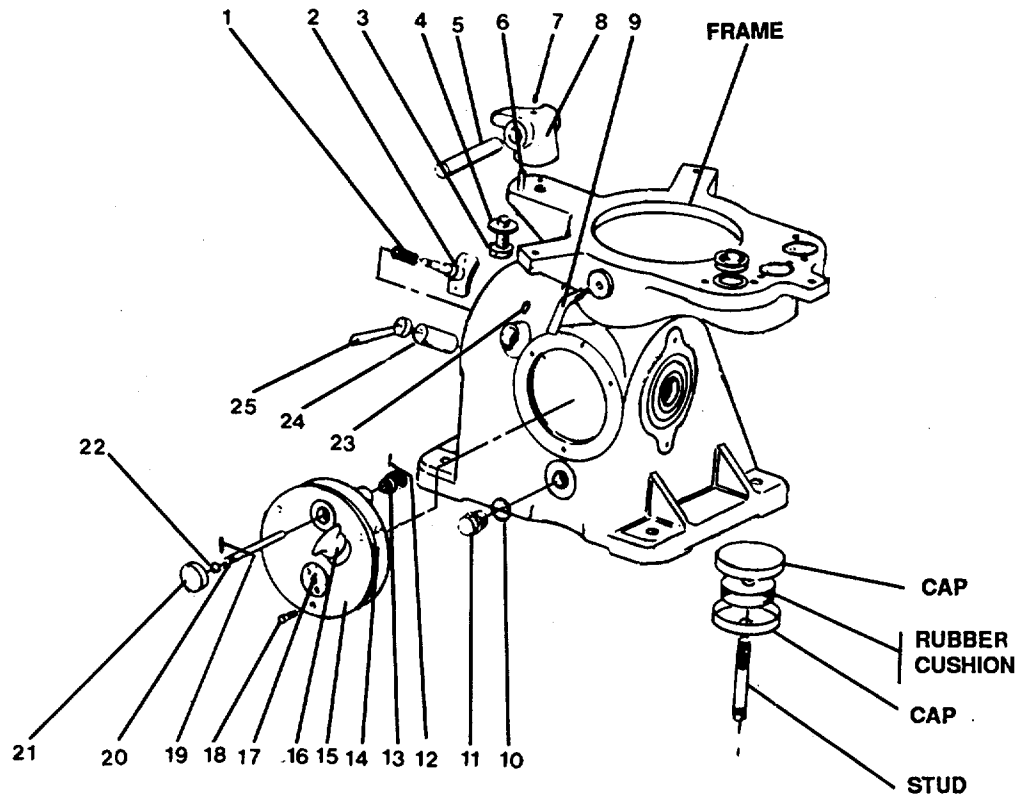

FIGURE 4-6. Purifier Frame Subassembly.

(5) Withdraw shaft from housing and remove preformed packing (22).

(6) Remove sight glass (17) by tapping or pressing on glass outward.

d. Brake Subassembly.

(1) Hand hold brake bolt (2) and turn handle (25) counterclockwise until brake bolt separates from brake housing (24).

(2) Remove break bolt and cylindrical spring (1) from gear box housing.

(3) Remove threaded pin (23).

(4) Remove brake housing (24) and handle (25) from frame.

e. Hood Support Subassembly.

(1) Remove threaded pin (7).

(2) Slide cylindrical pin (5) out of hood support (8).

(3) Remove machine screw (3) and flat washer (4).

(4) Separate and remove hood support from cylindrical pin (6) and frame top.

(5) Remove cylindrical pin (6) from frame top.

f. Bowl Assembly (Self-Locking Screw).

(1) Remove self-locking screw (9) by turning handle counterclockwise until screw is clear of frame.

(2) Remove self-locking screw on opposite side of frame.

g. Frame.

**NOTE**

Frame removal procedures are covered in paragraph 3-17, vertical gear assembly.

**REPAIR**

Repair of frame assembly consists of replacing: rubber cushions (6) (refer to disassembly note above), gaskets (2, 15, 12, 1, 14), preformed packing (22), sight glass (17).

**ASSEMBLY (Figure 4-5)**

a. Frame.

**NOTE**

Frame installation procedures are covered in paragraph 3-17, vertical gear assembly.

b. Bowl Assembly (Self-Locking Screws).

- (1) Install self-locking screw (9) into frame by turning handle clockwise several turns to secure handle in frame.
- (2) Install self-locking screw into opposite side of frame.

c. Hood Support Subassembly.

- (1) Install cylindrical pin(6) on frame top.
- (2) Position hood support (8) on cylindrical pin.
- (3) Install flat washer (4) and machine screw (3) and secure hood support to frame top.
- (4) Install cylindrical pin (5) into hood support (8).
- (5) Install threaded pin (7) and secure pin (5).

d. Brake Subassembly.

- (1) Install brake housing (24) and handle (25) on frame.
- (2) Install threaded pin (23).
- (3) Position cylindrical spring (1) and brake bolt (2) (inside gearbox housing) over brake housing (24).
- (4) Hand hold brake bolt (2) and turn handle (25) clockwise to engage brake bolt. Turn handle several more turns to make sure brake bolt is secured to brake housing.

e. Revolution Indicator Housing.

**NOTE**

For installing a new sight glass, use oil and heat resistant porcelain cement or two-component adhesive.

- (1) Apply a coating of cement around edges of sight glass lens frame on revolution housing (15).
- (2) Allow proper drying time in accordance with directions then, attach sight glass (17).

- (3) Install preformed packing (22) on shaft (20).
- (4) Install worm wheel (13) on shaft.
- (5) Install cylindrical notched pin (12) and secure worm wheel to shaft.
- (6) Install gasket (14) on revolution housing (15).
- (7) Position revolution housing on frame.
- (8) Install three machine screws (18) and secure housing to frame.
- (9) Install gasket (10) and oil drain screw (11).

f. Rubber Cushions.

**NOTE**

Refer to paragraph 3-17, vertical gear assembly for installation procedures of rubber cushions and caps.

- (1) Rubber cushions.
- (2) Caps.

**NOTE**

Refer to Figure 4-6 remaining assembly procedures.

g. Gaskets.

- (1) Position gasket (2) and flange (16) to underside of frame.
- (2) Install two machine screws (4) and secure gasket and flange.
- (3) Position gasket (15) and manifold (14) to lower ledge of frame.
- (4) Install two machine screws (4) and secure gasket and manifold.
- (5) Attach expansion joint (8) gasket (2) and flange (7) to gasket (12), gasket retainer (13) and manifold (14).
- (6) Install plate (10).
- (7) Install two plain hex nuts and secure plate to manifold.
- (8) Install clamp assembly (11).
- (9) Attach gasket (2) and flange (7) to expansion joint (8).
- (10) Install two machine screws and plain hex nuts and secure gasket and flange to expansion joint.

- (11) Position gasket (2) and flange (3) on side of frame.
- (12) Install two machine screws (4) and secure gasket and flange.
- (13) Install three gaskets (1) on frame top.

#### **REPLACEMENT**

- a. Install vertical gear assembly as specified in paragraph 3-17 .
- b. Install horizontal gear assembly as specified in paragraph 3-18 .
- c. Install bowl assembly as specified in paragraph 3-16 .
- d. Install motor assembly as specified in paragraph 2-17 .
- e. Install double gear pump assembly as specified in paragraph 2-19 .
- f. Install pump connection assembly as specified in paragraph 2-18 .
- g. Install hood assembly as specified in paragraph 2-20 .
- h. Fill gearbox with oil to slightly below full mark on sight glass (17). (See LO 55-1905-223-12).
- i. Remove tag and turn ON electrical power at P205 power/lighting panel.



**4-17. Repair Circulation Heater. (Figure 4-7)**

**This task covers:**

- a. Disassembly**
**b. Repair**
**c. Assembly**

**INITIAL SETUP :**

Tools

Tool kit, general mechanic's,  
5180-00-699-5273  
Tool kit, electrician's,  
5180-00-391-1087

Equipment Condition

Electrical power to lube oil purifier heater turned OFF at P205 power/lighting panel and tagged "Out of Service - Do Not Operate."

Materials/Parts

Heater element assembly  
P/N TMO-3061SE-2XX  
Heater thermostat  
P/N AR-2524LT  
Warning tags, Item 1, Appendix C

Suction and discharge valves closed and tagged "Out of Service - Do Not Operate."

**DISASSEMBLY**

a. Heater Element Assembly.

- (1) Remove four screws (4).
- (2) Remove terminal cover (5) from heater element assembly (3).
- (3) Tag and disconnect electrical wiring from terminals at heater element assembly.
- (4) Disconnect fittings (6) and remove wire harness (17) from heater element assembly.
- (5) Remove nuts (16) and bolts (1) from heater flanges (2).
- (6) Lift heater element assembly out of circulation heater (15).
- (7) Remove gasket (7).

b. Heater Thermostat.

- (1) Remove four screws (10).
- (2) Separate and position cover (9) with thermostat control circuit leads (14) clear of opening to junction box (8).

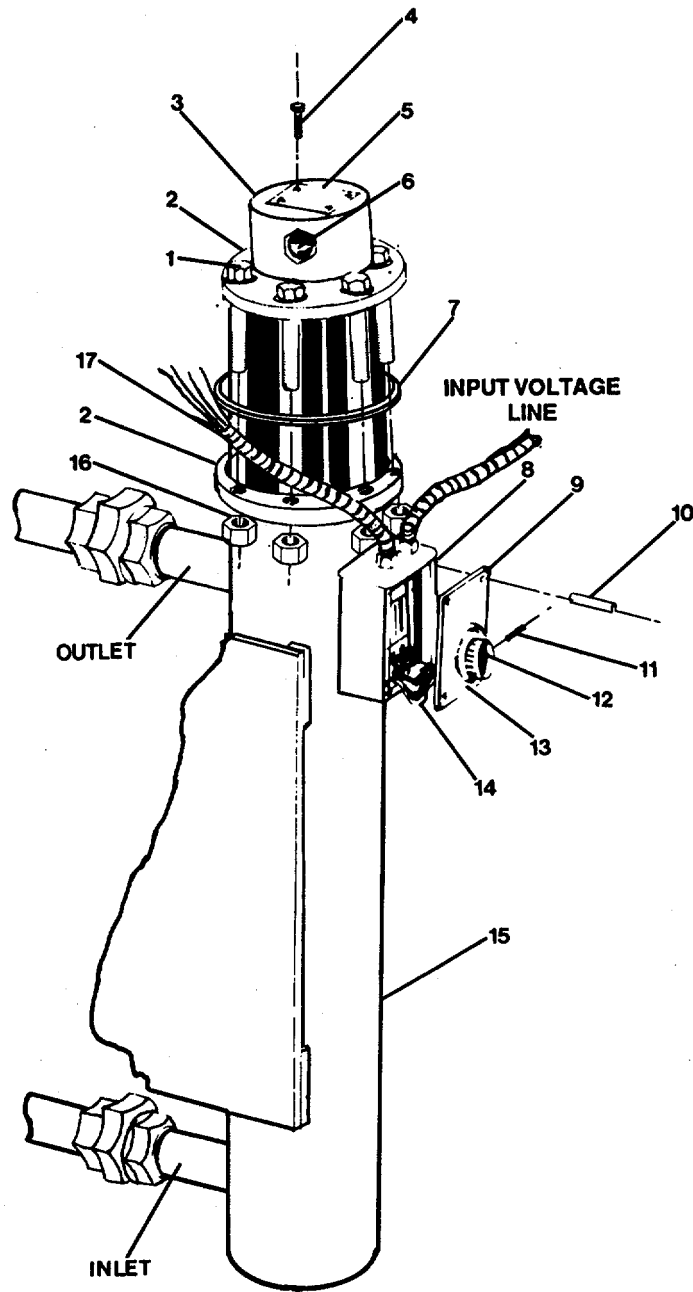

FIGURE 4-7. Heater Element Assembly.

- (3) Tag and disconnect wire leads from thermostat (13).
- (4) Loosen set screw (11) and remove knob (12).
- (5) Remove attaching hardware from thermostat.
- (6) Remove thermostat (13) from rear of cover (9).

## REPAIR

Repair of circulation heater consists of replacing heater element assembly (3) and heater thermostat (13).

## ASSEMBLY

### a. Heater Thermostat.

- (1) Position thermostat (13) on rear of cover (9).
- (2) Install attaching hardware on thermostat.
- (3) Install knob (12) and secure with set screw (11).
- (4) Connect wire leads (14) to thermostat. Remove tags.
- (5) Install thermostat control circuit leads (14) and cover (9).
- (6) Install four screws (10) and secure cover to junction box (8).

### b. Heater Element Assembly.

- (1) Position gasket (7) on flange (2).
- (2) Lower heater element assembly (3) into circulation heater (15).
- (3) Install bolts (1) and nuts (16) on flanges (2).
- (4) Install wire harness (17) and connect fittings (6) on heater element assembly.
- (5) Connect electrical wiring on terminals at heater element assembly. Remove tags.
- (6) Install terminal cover (5) on heater element assembly (3).
- (7) Install four screws (4).
- (8) Open suction and discharge valves. Remove tags.
- (9) Restore power to lube oil purifier heater. Remove tags.

**4-18. Repair Diesel Fuel Oil Filter/Separator. (Figure 4-8, Sheets 1 and 2)**

**This task covers:**

- a. Disassembly**
**b. Repair**
**c. Assembly**

**INITIAL SETUP :**

Tools

Tool kit, general mechanic's,  
5180-00-699-5273

Materials/Parts

Angle valve P/N 203927  
Valve assembly P/N 201720  
Warning tags, Item 1, Appendix C

Equipment Condition

Shut down - TM 55-1905-223-10  
Suction and discharge valves closed  
and tagged "Out of Service - Do  
Not Operate.

**DISASSEMBLY**

a. Angle Valve/Sight Glass.

- (1) Slowly open vent valve (6, Sheet 1) to relieve pressure in housing (5).
- (2) Open drain valve (7) and completely drain liquid from housing.
- (3) Open valves (2).
- (4) Disconnect couplers (3).
- (5) Remove angle valve/sight glass (1) from housing.
- (6) Remove gaskets (4).

b. Inlet/Outlet Plates.

Refer to removal procedures paragraph 3-20.

c. Differential Pressure Gage/Valve Assembly.

- (1) Open root valves (25, Sheet.2) to release residual pressure and liquid in pressure lines.
- (2) At bottom of instrument panel (8), disconnect tube coupling nuts (30).
- (3) Remove eight hex self-locking nuts (18) and hex head capscrews (17) securing instrument panel to mounting bracket (20).

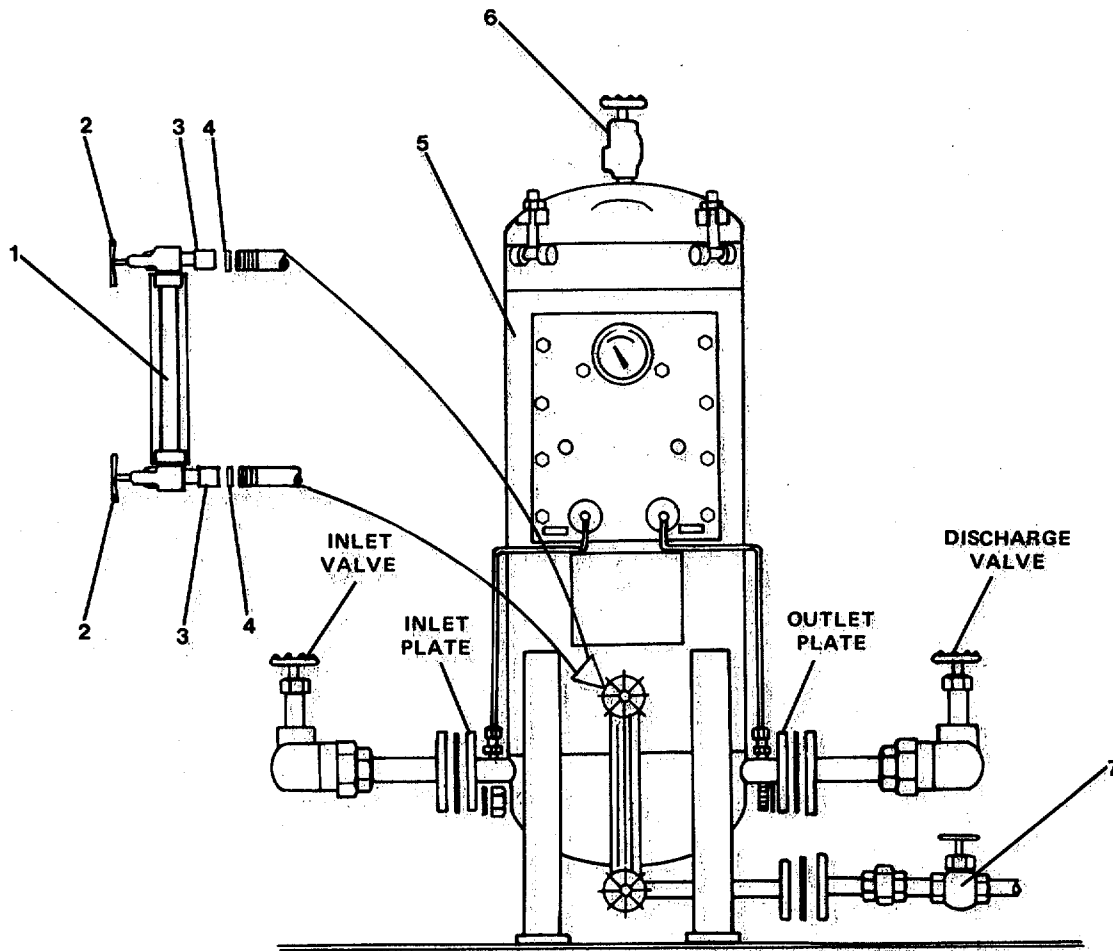

FIGURE 4-8. Diesel Fuel Oil Filter/Separator (Sheet 1 of 2).

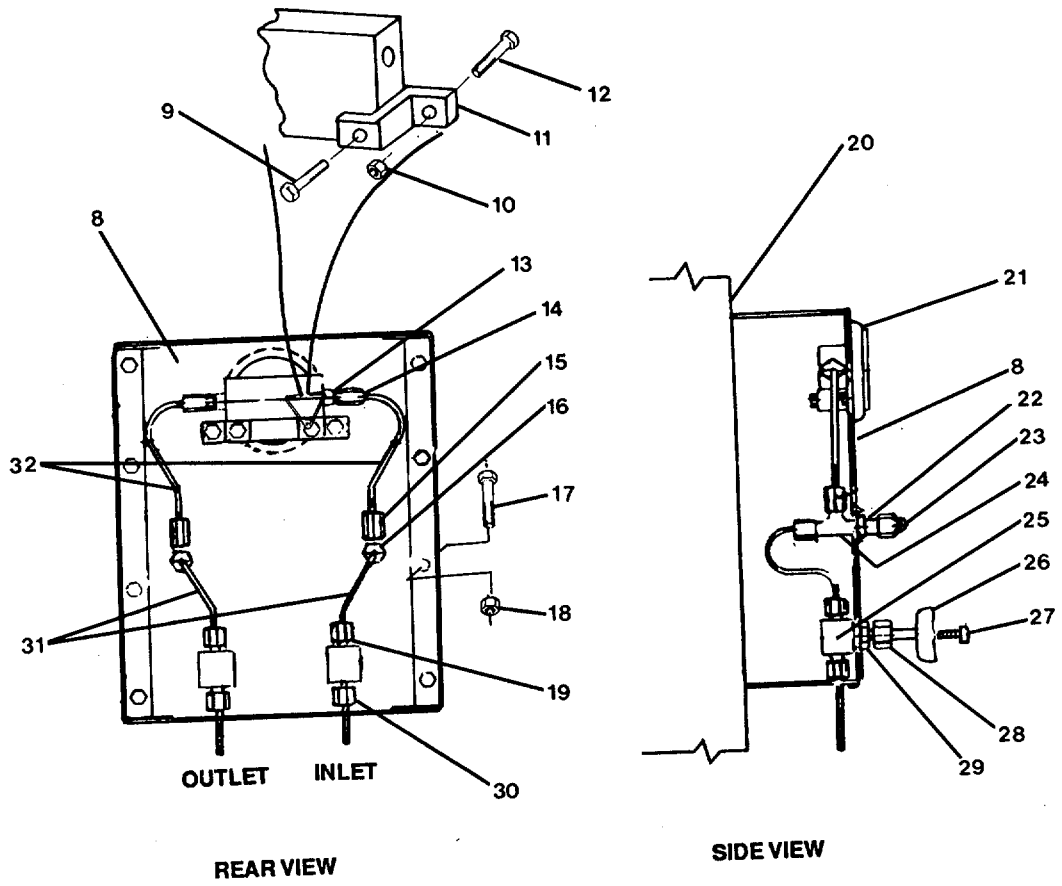

FIGURE 4-8. Diesel Fuel Oil Filter/Separator (Sheet 2 of 2).

- (4) Remove panel and position on a clean flat surface.
- (5) Position a 5/8 inch wrench on gland nuts (13) to prevent nuts from rotating, position a second 5/8 inch wrench on coupling nuts (14) and loosen nuts completely.
- (6) With coupling nuts (14) completely loosened, gently hold tubings (32) and pull up on coupling nuts to break seals free of tubings.
- (7) Remove gland nuts (13) from differential pressure gage (21) housing.
- (8) Remove two hex self-locking nuts (10) and hexhead capscrews (12) securing gauge support brackets (11) to back of panel.
- (9) Remove two hex head capscrews (9) securing support bracket (11) to pressure gauge.
- (10) Remove pressure gauge from front panel.
- (11) Disconnect tube coupling nuts (15).
- (12) Remove pressure lines (32).
- (13) Disconnect tube coupling nuts (16) and (19) from both flareless tube tees (24) and valve assemblies (25).
- (14) Remove pressure lines (31).
- (15) Remove tube caps (23).
- (16) Remove tube fittings locknuts (22),
- (17) Slide flareless tube tees (24) out of back side of panel.
- (18) Remove screws (27) from root valves (25) and remove handwheel (26).
- (19) Remove gland nuts (28) and locknuts (29).
- (20) Slide root valves (25) out of back side of panel.

## REPAIR

Repair of diesel fuel oil filter/separator and subassembly consists of replacing angle valve (1), valve assembly (25).

## ASSEMBLY

- a. Valve assembly/differential pressure gauge.
  - (1) Position root valves (25) on instrument panel (8).
  - (2) Install locknuts (29) and secure root valves to panel.

- (3) Install gland nuts (28).
- (4) Position handwheels (26) on valves and secure handwheels with screws (27).
- (5) Position flareless tube tees (24) on panel.
- (6) Install tube fitting locknuts (22) and secure flareless tube tees to panel.
- (7) Install tube caps (23).
- (8) Position pressure lines (31).
- (9) Connect tube coupling nuts (19) and (16) to both valves assemblies (25) and flareless tube tees (24).
- (10) Position pressure lines (32).
- (11) Connect tube coupling nuts (15).
- (12) Position differential pressure gauge (21) on front panel.
- (13) Install two hex head capscrews (9) and secure gauge support brackets (11) to pressure gauge housing.
- (14) Install two hex head capscrews (12) from front of panel and aligned with support bracket mounting screw holes. Secure support bracket to back of panel with two hex self-locking nuts (10).
- (15) Install gland nuts (13) on pressure gauge (21) housing.
- (16) Install coupling nuts (14) with attaching seals on tubings (32) at pressure gauge.
- (17) Position coupling nuts (14) on pressure gauge.
- (18) Position a 5/8 inch wrench on gland nuts (13) to prevent nuts from rotating. Position a second 5/8 inch wrench on coupling nuts (14) to secure pressure lines to pressure gauge.
- (19) Position instrument panel (8) over mounting screw holes on support bracket (20).
- (20) Install eight hex head capscrews (17) from front of panel and secure panel to support bracket with hex self-locking nuts.
- (21) At bottom of instrument panel, connect tube coupling nuts (30) to both valve assemblies (25).
- (22) Close inlet and outlet root valves (25) to isolate differential pressure gauge (21) from initial start-up conditions.



b. Inlet/outlet plates.

Refer to replacement procedures paragraph 3-20 .

c. Angle valve/sight glass.

- (1) Install gaskets (4).
- (2) Position angle valve/sight glass (1) on housing (5).
- (3) Connect couplers (3).
- (4) Close valves (2).
- (5) Close drain valve (7).
- (6) Close vent valve (6).
- (7) Open discharge valve. Remove tag.

**WARNING**

To prevent injury to personnel, ensure that the ship's vent valve is open and that a low pressure (10 psig or less) is used to fill filter housing until all air has escaped.

- (8) Open suction valve. Remove tag.
- (9) Refer to initial start-up procedures in TM 55-1905-223-10.

---

**4-19. Calibrate Control Module Assembly and Sensing Module Assembly. (Figure 4-9)**

---

**This task covers:**

**Calibration.**

---

**INITIAL SETUP:**

Tools

Tool kit, general mechanic's,  
5180-00-699-5273  
Tool kit, electrician's,  
D 5180-00-391-1087  
Multimeter 6625-01-139-2512

Equipment Condition

Control module assemblies and sensing  
module operational as specified in  
paragraph 2-28 .

---

**CALIBRATION**

**NOTE**

The Oil Content Alarm (OCA) is calibrated to maintain the linear relationship between the amplifying voltages and the parts per million (ppm) readouts of the Digital Display. The OCA has been factory calibrated in ppm. However, the unit should be recalibrated whenever any of the electronic components in the OCA such as the Logic Board, the Amplifier Board, the Power Supply Board, the Transformer Board, the incandescent lamp, the photo diodes, etc., are replaced. The following procedures are used to check the calibration and to recalibrate the OCA. A Simpson 260 test meter or equivalent should be used for voltage checks.

- a. Turn power switch (1) on.

**WARNING**

Excercise extreme care while working on electrical components inside control module. Accidental contact with energized components may result in injury to personnel or equipment damage.

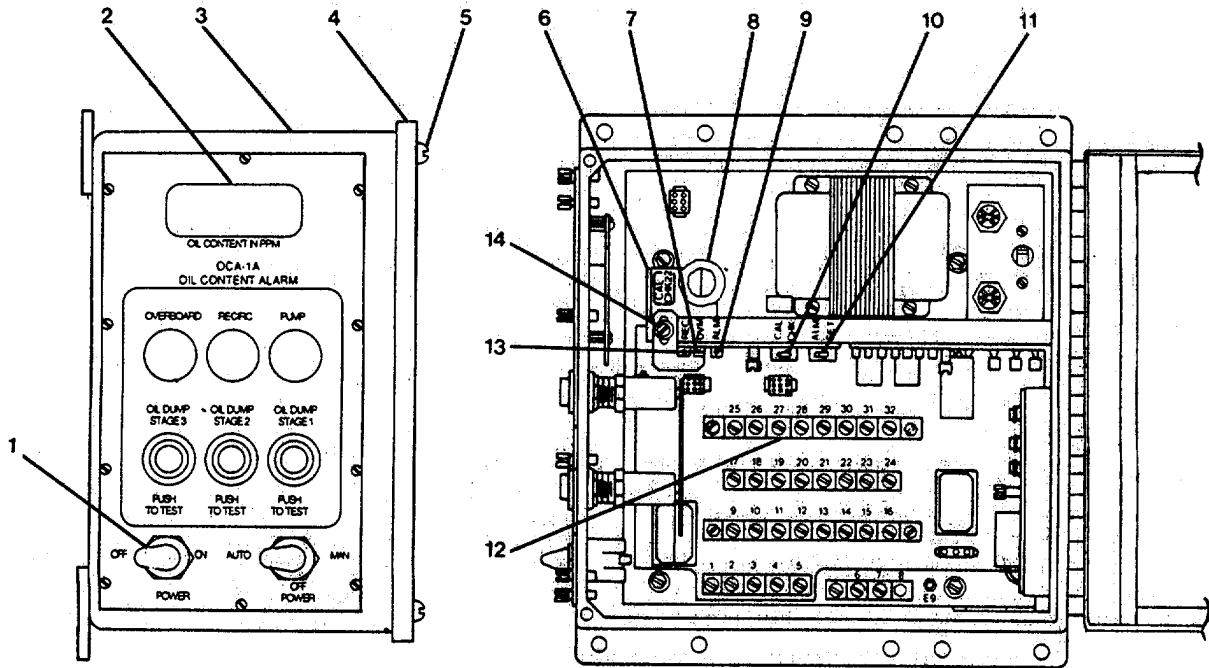

FIGURE 4-9. Control Module Assembly.

- b. Loosen two machine screws (5) and open side panel cover (4) on control module (3).
- c. Hold alarm set switch (11) in SET.
- d. Turn alarm set point adjustment screw (9) until desired reading is obtained on digital display (2). Desired reading is indicated by calibration CAL CHECK (6).
- e. Run clean water having a zero ppm value through sensing module.
- f. Attach leads of test meter to terminal contacts 27 (+) and 28 (-) of terminal board (12).
- g. When conditions have stabilized, a reading of 0 Vdc should be obtained. See Table 4-3 .

**Table 4-3. Control Module Output Voltage for ppm.**

ppm Indication (ppm)	Output Voltage (dc volts)
100	10
50	5
10	1
5	0.5
0	0

- h. Release and swing aside REC (Receive) and DVM (Digital Voltmeter) adjustment guard (14).
- i. Calibrate output as indicted above by adjusting recorder (REC) adjusting screw (13) while observing voltage reading on test meter.
- j. Remove leads of test meter from terminal contacts 27 (+) and 28 (-) of terminal board (12).
- k. Adjust digital voltmeter (DVM) adjustment screw (7) to obtain proper ppm value on digital display (2). Unit is now calibrated to read ppm.
- l. Reinstall REC and DVM adjustment guard (14) in original position.

**NOTE**

Release knob lock before attempting to turn zero adjustment knob.

- m. When oil-free water turbidity changes, this change can be calibrated out by running a sample of the oil-free water through unit and adjustment of zero adjustment knob (8) to obtain a reading of 00 on digital display (2).

- n. Hold calibration check switch (10) in CHECK position. Observe the reading on the digital display (2) and observe that this number is the same (within 2 + ppm) as the number recorded on the label (6) affixed to the interior of the control module.

**NOTE**

This number, the calibration check number, is used as the standard reference until the OCA is recalibrated or serviced and a new calibration check number is established. Although the ppm value of the effluent may vary during normal system operation, the calibration check remains constant. The calibration check number is equal to the difference between the digital reading obtained when the Calibration Check Switch is in the CHECK position and effluent ppm digital read out.

- o. Release the Calibration Check Switch (10) and observe that the Digital Display (2) still reads zero (00).
- p. Close and secure side panel cover (4) of control module (3) with two machine screws (5).

---

**4-20. Repair Motorized Oil Pump Assembly. (Figure 4-10)**

---

This task covers:

- a. Disassembly,                      b. Repair,                      c. Assembly.
- 

**INITIAL SETUP:**

Tools

Tool kit, general mechanic's,  
5180-00-699-5273

Equipment Condition

Oil pump/motor assembly removed  
as specified in paragraph 3-31 .

Materials/Parts

Stator P/N 4330-1545-002  
Stator ring P/N 4320-2361-000  
Rotor P/N 4320-4559-002  
Universal joint P/N 4320-1612-000  
Mechanical seal P/N 4320-2424-000  
Motorized pump P/N 33260  
Pump drive motor P/N 4330-04528-000  
Lubrication oil, Item 20, Appendix C

---

**DISASSEMBLY**

- a. Position motorized pump (15) on a clean flat surface.
- b. Remove eight machine screws (8) securing housing (7) to pump body.
- c. Separate and remove housing from pump body.
- d. Slide stator ring (6) and stator (9) off of rotor (5).
- e. Separate rotor (5) from universal joint (3) by using a punch to remove pin (4). Support rotor when removing pin. Retain pin (4) for assembly.
- f. Separate universal joint (3) from motor shaft by using a punch through outlet port on pump body to remove pin (2). Retain pin (2) for assembly.
- g. Slide universal joint off of motor shaft and out of pump body.

**NOTE**

If any part of mechanical seal is broken or damaged, the complete seal assembly must be replaced.

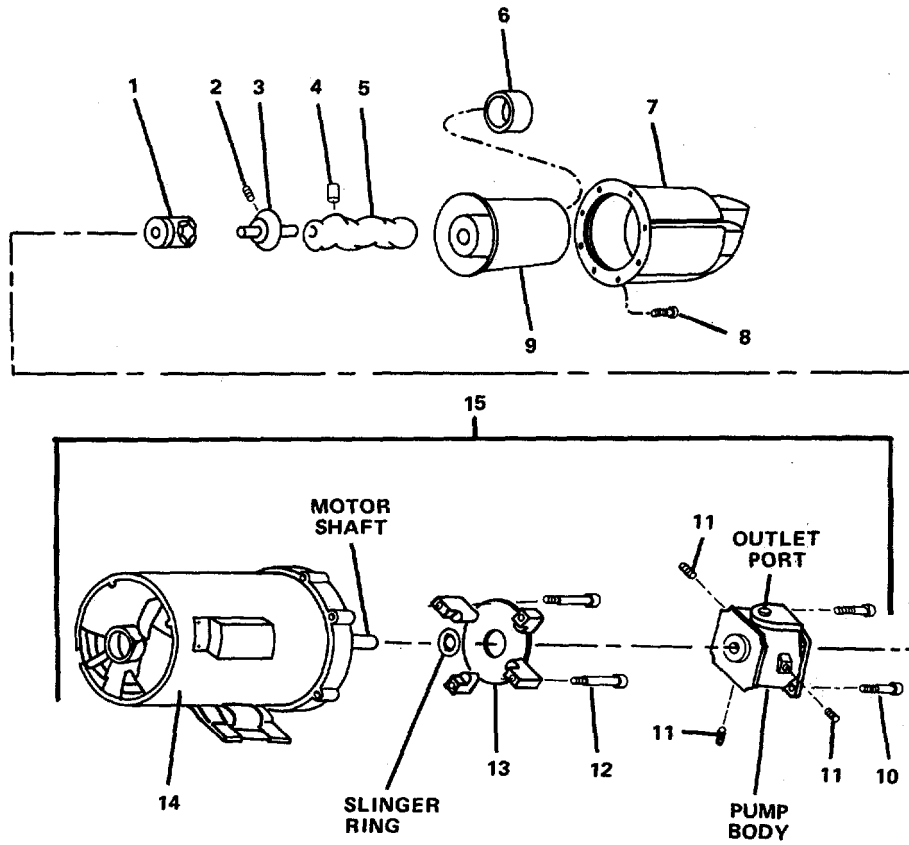

FIGURE 4-10. Motorized Oil Pump.

- h. Carefully slide mechanical seal (1) off motor shaft and out of pump body.
- i. Remove four machine screws (10) securing pump body to fluid control ring (13).
- j. Separate and remove pump body from motor shaft and fluid control ring.
- k. Remove three pipe plugs (11) from pump body.
- l. Remove four machine screws (12) securing fluid control ring (13) to pump drive motor (14).
- m. Separate and remove fluid control ring (13) and slinger ring from pump drive motor (14) shaft.

## REPAIR

Repair of motorized pump consists of replacing stator (9), stator ring (6), rotor (5), universal joint (3), mechanical seal (1) motorized pump (15), pump drive motor (14).

## ASSEMBLY

- a. Position pump drive motor (14) on a clean flat surface.
- b. Clean and oil motor shaft using clean light oil (not grease).
- c. Install slinger ring and fluid control ring (13) on motor shaft with mounting screw holes aligned with pump drive motor.
- d. Install four machine screws (12) and secure fluid control ring (13) to pump drive motor (14).
- e. Install three pipe plugs (11) on pump body.
- f. Position pump body on motor shaft with mounting screw holes aligned with fluid control ring (13).
- g. Install four machine screws (10) and secure pump body to fluid control ring.
- h. Clean and oil lapped sealing faces of mechanical seal (1) using clean light oil (not grease).
- i. Oil outer surface of mechanical seal seat, then install seat on motor shaft and into the pump body.
- j. Position universal joint (3) on motor shaft with pin holes aligned. (Ensure that mechanical seal (1) is properly seated in pump body.)
- k. Install pin (2) by using a punch through outlet port on pump body to secure pin (2) on motor shaft.



- l. Position rotor (5) on universal joint (3) with pin holes aligned. Support rotor and universal joint when pin is installed.
- m. Install pin (4) by using a punch to secure rotor (5) to universal joint (3).
- n. Install stator (9) and stator ring (6) on rotor (5).
- o. Position housing (7) on pump body with mounting screw holes aligned. (Ensure that inlet port on housing (7) is vertically aligned with outlet port on pump body.)
- p. Install eight machine screws (8) and secure housing (7) to pump body.
- q. Oil pump/motor assembly replaced as specified in paragraph 3-31 .

---

**4-21. Repair Motorized Water Pump Assembly. (Figure 4-11)**

---

**This task covers:**

- a. Disassembly,                      b. Repair,                      c. Assembly.**
- 

**INITIAL SETUP:**Tools

Tool kit, general mechanic's,  
5180-00-699-5273

Equipment Condition

Water pump/motor assembly removed  
as specified in paragraph 3-32 .

Materials/Parts

Stator P/N 330-1006-001  
Rotor P/N 320-1569-002  
Universal joint P/N 320-1612-000  
Mechanical seal P/N 320-2424-000  
Lubricating oil, Item 20, Appendix C

---

**DISASSEMBLY**

- a. Position motorized pump (14) on a clean flat surface.
- b. Remove six machine screws (7) securing housing (6) to motorized pump.
- c. Separate and remove housing (6) from pump.
- d. Remove pipe plug (8) from housing.
- e. Slide stator (9) off of rotor (5).
- f. Separate rotor (5) from universal joint (3) by using a punch to remove pin (4). Support rotor when removing pin. Retain pin for assembly.
- g. Separate universal joint (3) from motor shaft by using a punch through outlet port on pump body to remove pin (2). Retain pin for assembly.
- h. Slide universal joint off of motor shaft and out of motorized pump (14).

**NOTE**

If any part of mechanical seal is broken or damaged, the complete seal assembly must be replaced.

- i. Carefully slide mechanical seal (1) off motor shaft and out of motorized pump (14).

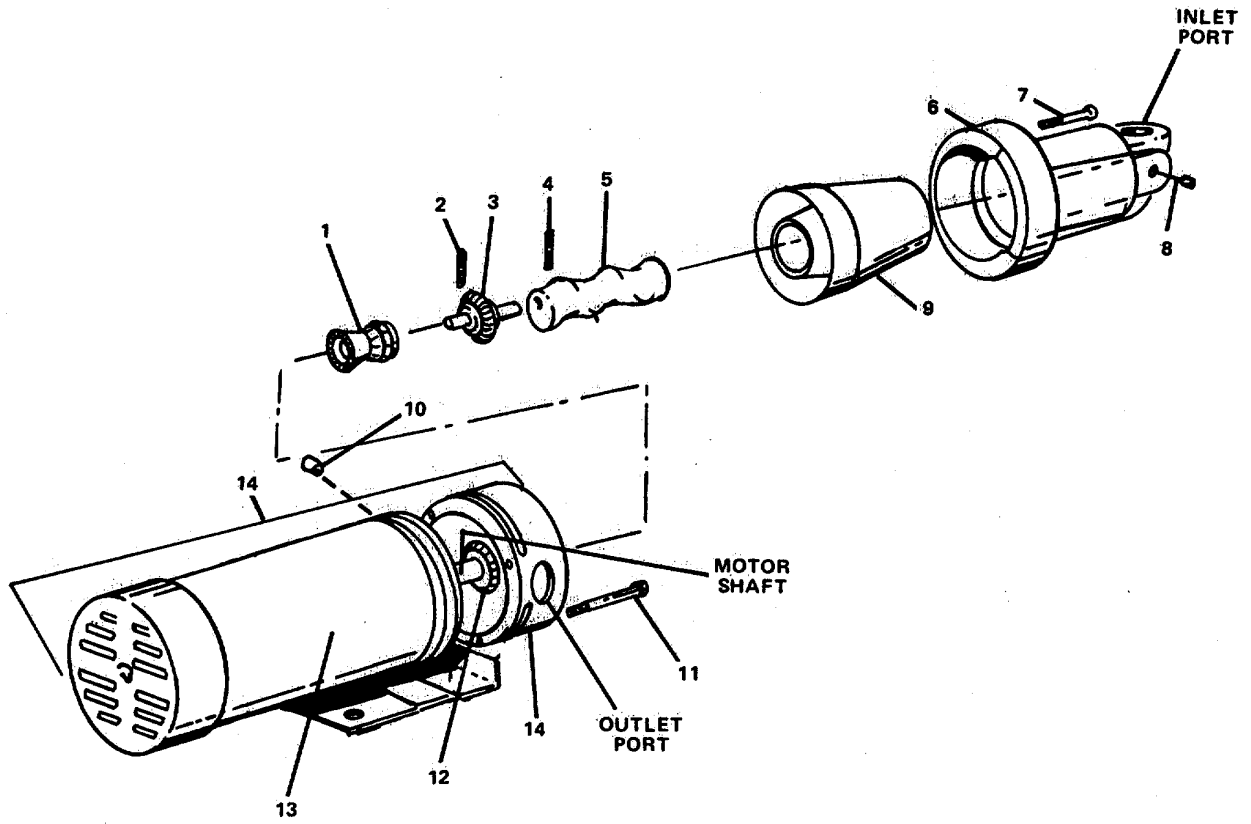

FIGURE 4-11. *Motorized Water Pump.*

- j. Remove four machine screws (11) securing motorized pump (14).
- k. Separate and remove motorized pump (14) and fluid control ring (12) from motor shaft.
- l. Remove pipe plug (10) from motorized pump (14).

## REPAIR

Repair of motorized pump assembly consists of replacing stator (9), rotor (5), universal joint (3), mechanical seal (1) motorized pump (14).

## ASSEMBLY

- a. Position motor (13) (part of motorized pump 14) on a clean flat surface.
- b. Install pipe plug (10) on motorized pump (14).
- c. Clean and oil motor shaft using clean light oil (not grease).
- d. Install fluid control ring (12) on motorized pump (14) on motor shaft with mounting screw holes aligned with motor (13).
- e. Install four machine screws (11) and secure motorized pump (14) to motor.
- f. Clean and oil lapped sealing faces of mechanical seal (1) using clean light oil (not grease).
- g. Oil outer surface of mechanical seal seat, then install seal on motor shaft and into the motorized pump.
- h. Position universal joint (3) on motor shaft with pin holes aligned. (Ensure that mechanical seal (1) is properly seated in pump body.)
- i. Install pin (2) by using a punch through outlet port of motorized pump (14) to secure pin (2) on motor shaft.
- j. Position rotor (5) on universal joint (3) with pin holes aligned. Support rotor and universal joint when pin is installed.
- k. Install pin (4) by using a punch to secure rotor (5) to universal joint (3).
- l. Install stator (9) on rotor (5).
- m. Position housing (6) on motorized pump with mounting screw holes aligned. (Ensure that inlet port on housing (6) is horizontally aligned with outlet port on motorized pump (14).
- n. Install six machine screws (7) and secure housing (6) to motorized pump (14).
- o. Water pump/motor assembly replaced as specified in paragraph 3-32 .

---

**4-22. Repair Sensor Manifold. (Figure 4-12 Sheets 1 and 2)**

---

This task covers:

- a. Disassembly,                      b. Repair,                      c. Assembly.
- 

**INITIAL SETUP:**

Tools

Tool kit, general mechanic's,  
5180-00-699-5273  
Tool kit, electrician's,  
5180-00-391-1087

Equipment Condition

Sensing module assembly removed as  
specified in paragraph 3-33 .

Materials/Parts

Sensor manifold P/N 335-E

---

**DISASSEMBLY**

- a. Position sensor manifold on clean flat surface.
- b. Photo diode.
  - (1) Remove four machine screws (17).
  - (2) Remove sensor end cap (16) and preformed packing (15).
  - (3) Tag and desolder photo diode leads from terminals 5, 6 and 7 on terminal board (18).
  - (4) Unscrew and remove retainer plug (7) and preformed packing (5).
  - (5) Lift diode retainer (3) out of housing (20).
  - (6) Lift photo diode (2) and wire leads out of housing.
  - (7) Lift diode support (1) preformed packing (36) and side window (31) out of housing.
- c. Side window.
  - (1) Remove four machine screws (27),
  - (2) Remove light detector cap (28) and preformed packing (29).
  - (3) Remove light spacer (32) light pad (33) side window (25) and preformed packing (26).

d. Direct window.

- (1) Remove two machine screws (19).
- (2) Separate terminal board (18) from support (14).
- (3) Position terminal board clear of inner optical block (13).
- (4) Unscrew and remove barrel (12) from inner optical block (13).
- (5) Remove barrel lens (11) lens retainer (10) window support (9) and preformed packing (8).
- (6) Remove alignment spacer (21).
- (7) Remove preformed packing (6).
- (8) Remove direct window (4).

e. Bushings.

- (1) Remove roll pin (22).
- (2) Remove bushing (23),
- (3) Remove preformed packing (24).

## REPAIR

Repair of sensor manifold assembly consists of replacement of defective parts.

## REPLACEMENT

a. Position sensor manifold on a clean flat surface.

b. Bushings.

- (1) Install preformed packing (24) into housing (20).
- (2) Install bushing (23).
- (3) Install roll pin (22) into bushing (23).

c. Direct window.

- (1) Install direct window (4) into inner optical block (13).
- (2) Install preformed packing (6).
- (3) Install alignment spacer (21).
- (4) Install preformed packing (8) window support (9) lens retainer (10) and barrel lens (11).

- (5) Install barrel (12) by screwing barrel into inner optical block (13).
- (6) Position terminal board (18) over support (14) with screw holes aligned.
- (7) Install two machine screws (19) and secure terminal boards to support (14).

d. Side window.

- (1) Install preformed packing (26) side window (25) light pad (33) and light spacer (32).
- (2) Position preformed packing (29) and light detector cap (28) on housing (20).
- (3) Install four machine screws (27) and secure light detector cap to housing.

e. Photo diode.

- (1) Lower side window (31) preformed packing (30) and diode support (1) into housing.
- (2) Lower photo diode (2) and wire leads into housing. Direct wire leads through housing and out front end of sensing module assembly.
- (3) Lower diode retainer (3) over photo diode (2).
- (4) Install preformed packing (5) and screw retainer plug (7) into housing.
- (5) Solder photo diode leads to terminals 5, 6 and 7 on terminal board (18). Remove tags.
- (6) Install preformed packing (15) on sensor end cap (1b).
- (7) Position sensor end cap over housing (20) with screw holes aligned.
- (8) Install four machine screws (17) and secure sensor end cap to housing.
- (9) Sensing module assembly replaced as specified in paragraph 3-33 .

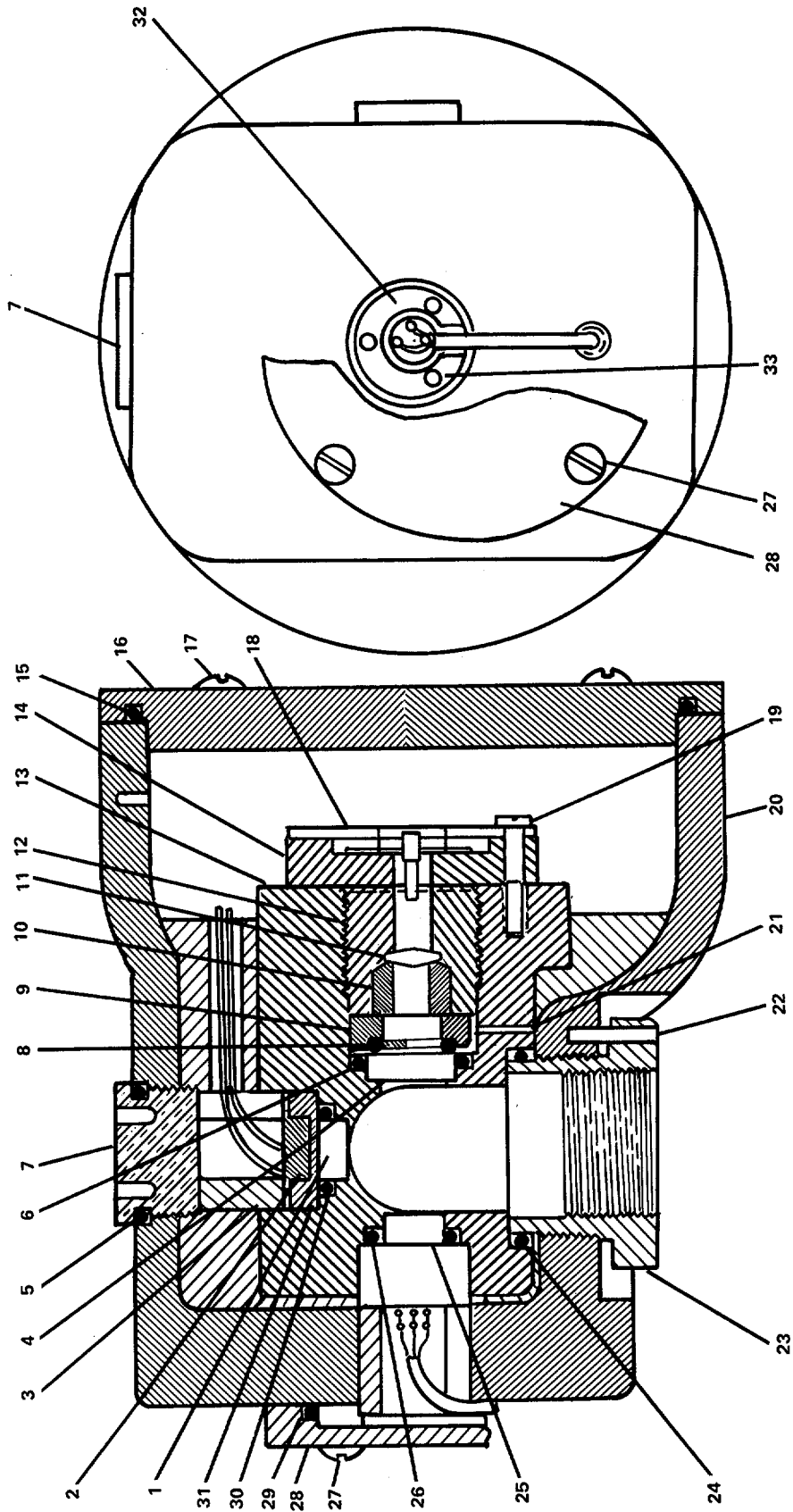

FIGURE 4-12. Sensing Module Assembly (Sheet 1 of 2).



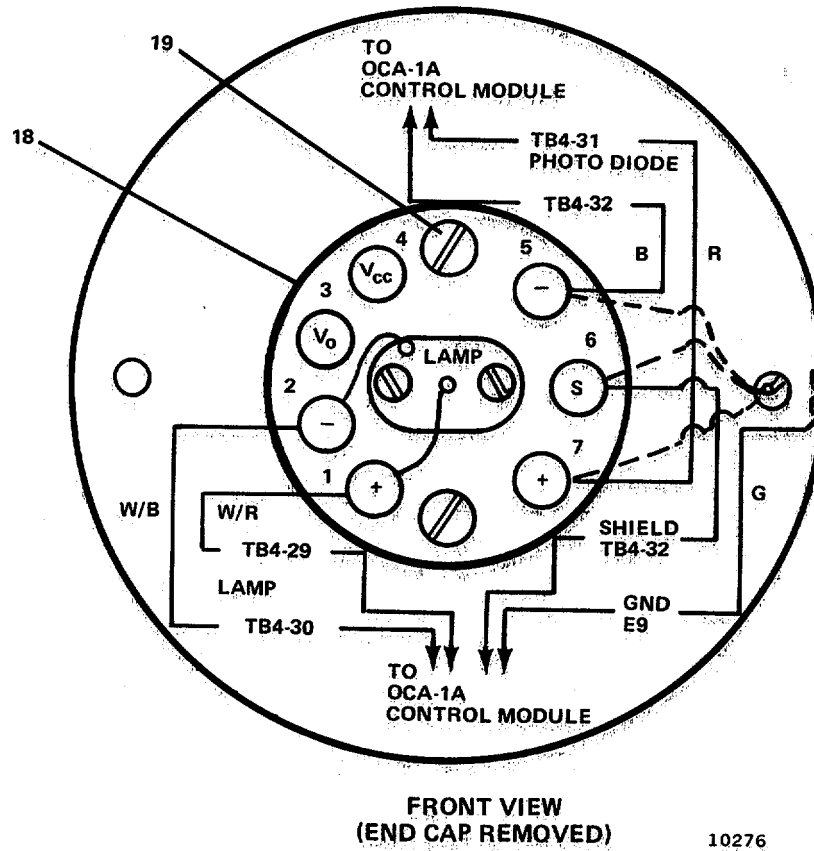

FIGURE 4-12. Sensing Module Subassembly (Sheet 2 of 2).

**MAINTENANCE OF PROPELLER SHAFT ASSEMBLY**

---

**4-23. Replace/Repair Propeller Shaft Assembly. (Figure 4-13)**

---

**This task covers:****a. Removal,****b. Repair,****c. Replacement.**

---

**INITIAL SETUP:**Tools

Tool kit, general mechanic's,  
5180-00-699-5273  
Special purpose wrench tool  
Drawing 8243008, Detail 53A

Equipment Condition

Vessel in shipyard drydock facility.

Materials/Parts

Lock wire P/N 43-0922-0040  
Packing material P/N 27-2649-0000  
Marine propeller P/N 78-5025-0002  
(left hand - Port)  
Marine propeller P/N 78-5025-0001  
(right hand - Starboard)  
John Crane zip joint P/N 27-4025-8024  
(15 feet)  
Chock fast orange resin  
P/N J1-1013-0000  
Packing material P/N 27-2756-8039  
Sleeve bearing P/N 49-1100-0000  
Propulsion ship shaft P/N 49-4377-0000  
Cleaning solvent Item 41, Appendix C  
Rags, Item 14, Appendix C  
Loctite kit, Item 12, Appendix C

---

**REMOVAL**

- a. Secure port propeller (31, Sheet 1) or starboard propeller (32) to prevent propulsion shaft (7) from turning.
- b. Support expander tube brake assembly (15) and remove the assembly mounting support plates. Refer to Chapter 3 .
- c. While supporting the expander tube brake assembly (15), move it aft enough down the shaft (7) to have enough clearance to disconnect shaft coupling flange (16).



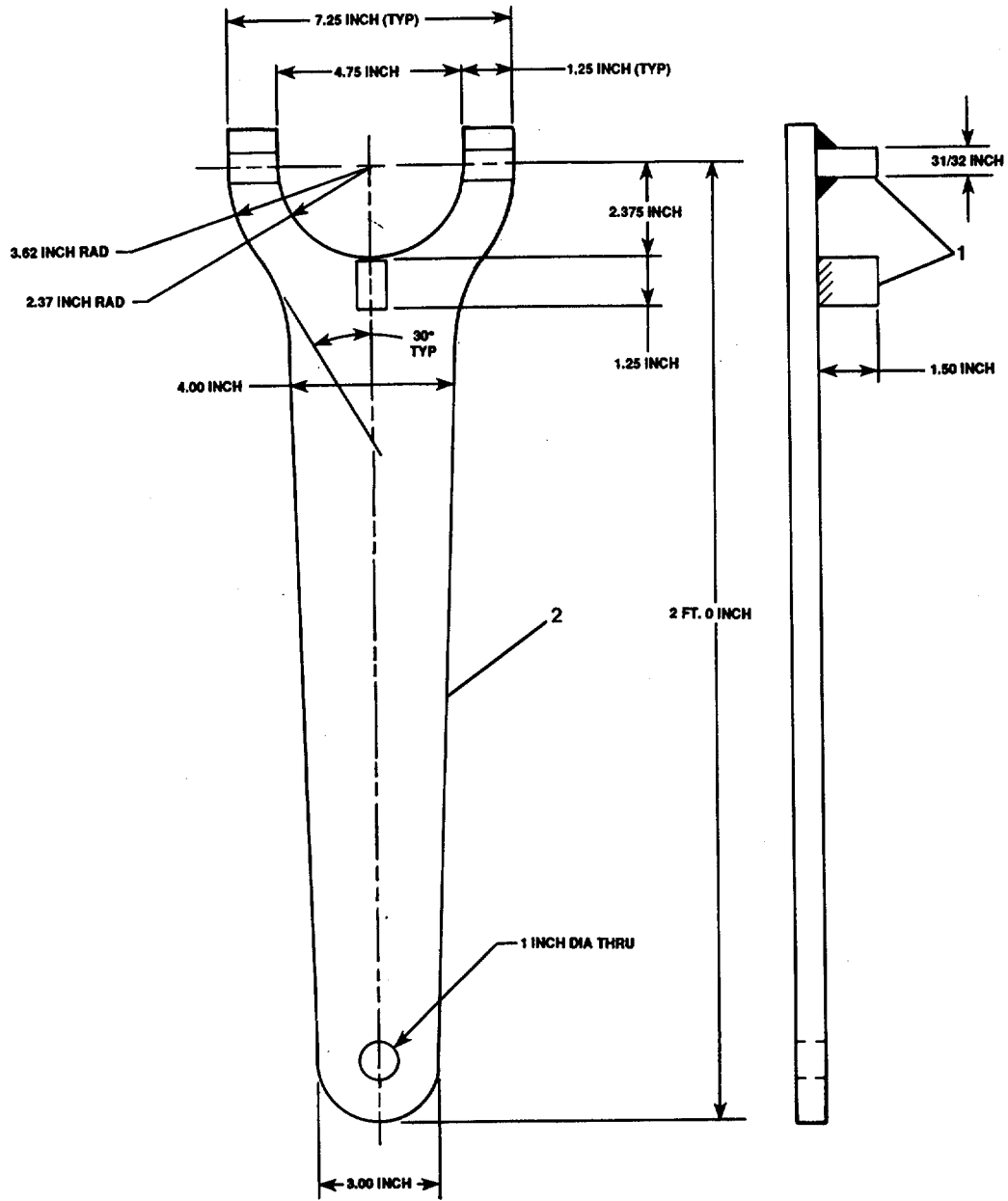

FIGURE 4-13. *Propeller Shaft Assembly (Sheet 2 of 5).*

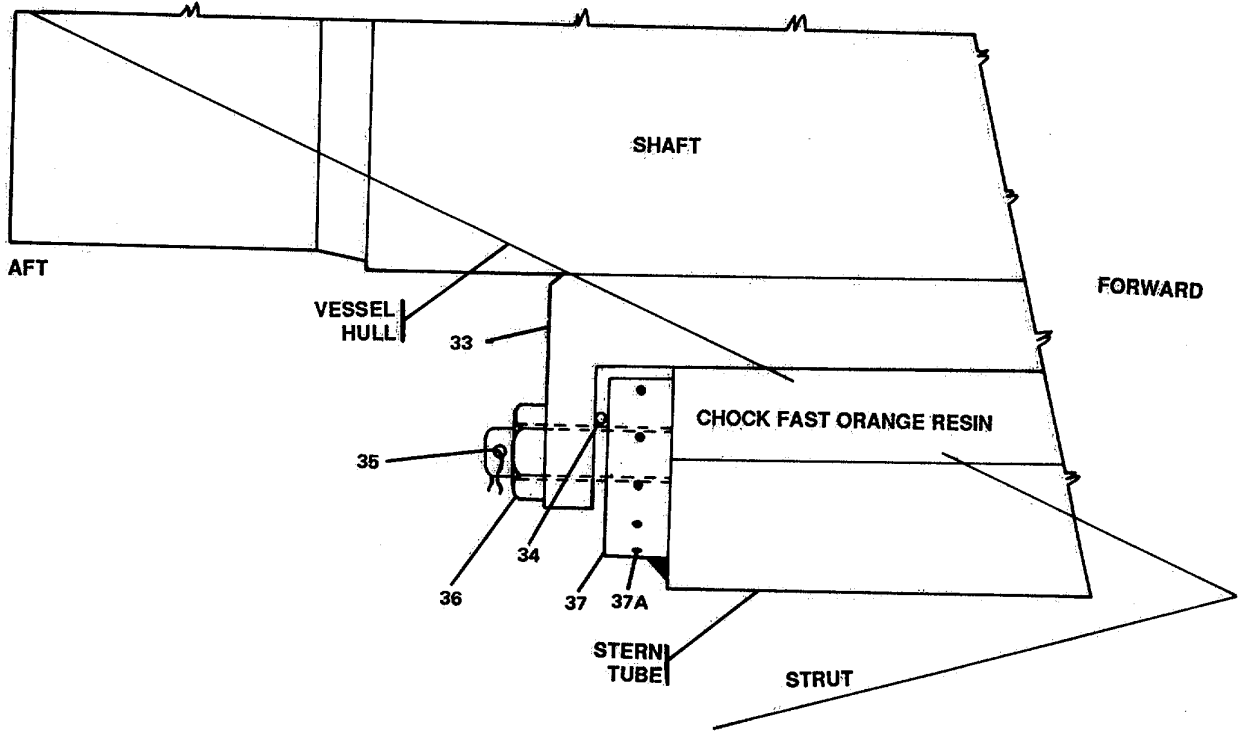

FIGURE 4-13. *Propeller Shaft Assembly (Sheet 3 of 5).*

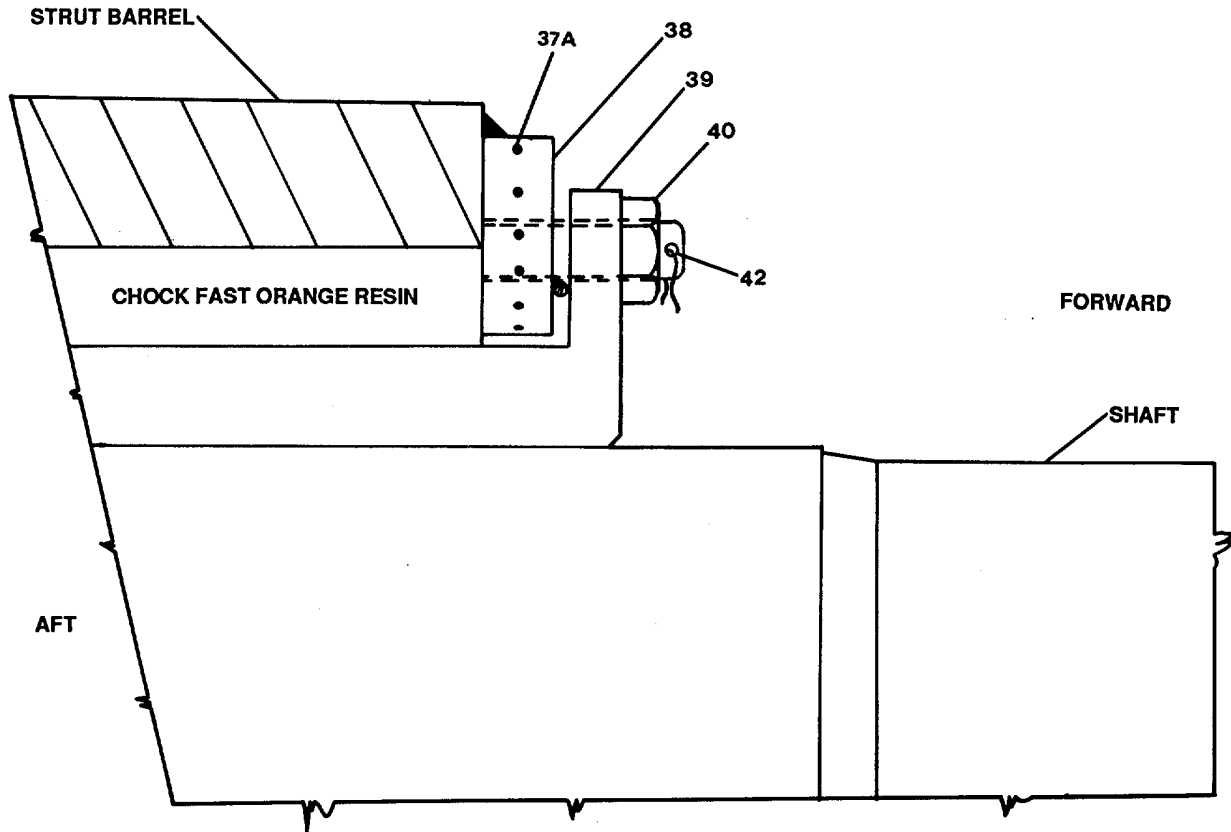

FIGURE 4-13. *Propeller Shaft Assembly (Sheet 4 of 5).*

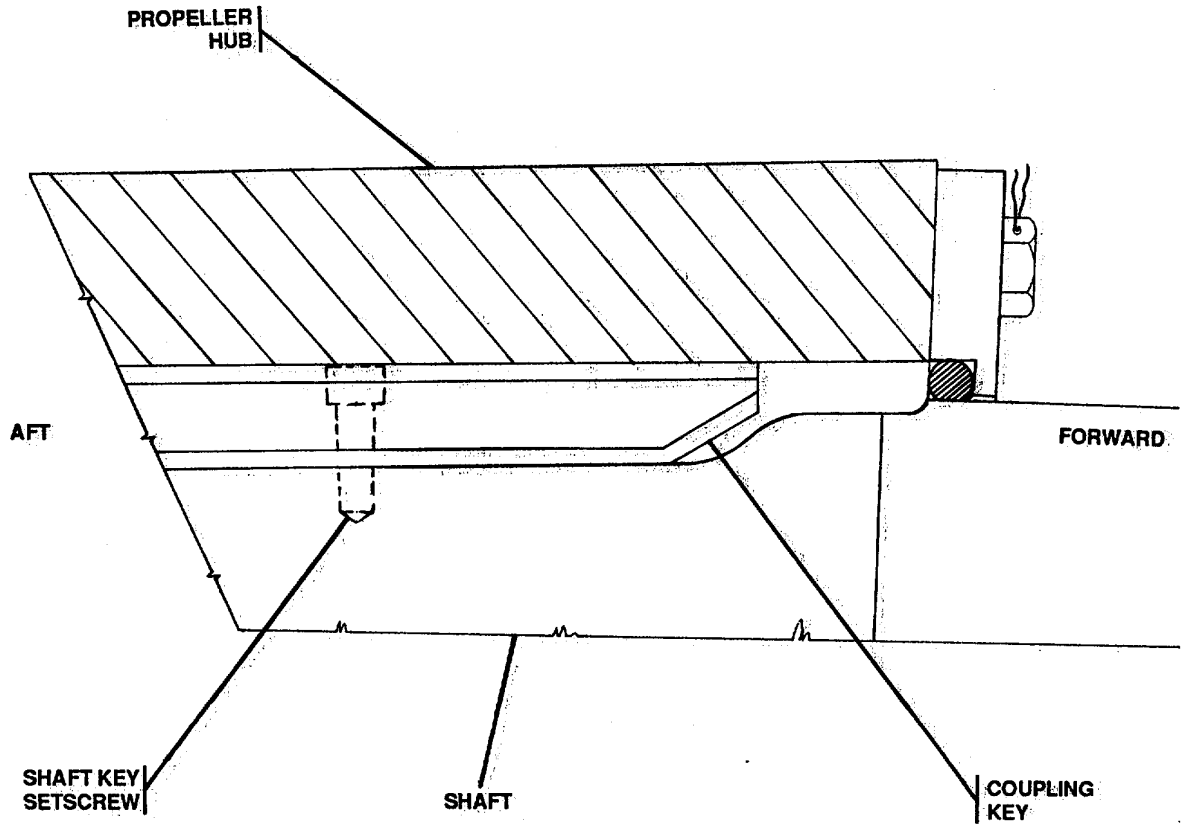

FIGURE 4-13. *Propeller Shaft Assembly (Sheet 5 of 5).*

- d. Mark the sixteen hex head capscrews (22) securing shaft coupling flange (16) to reduction gearbox to the holes on the coupling to ensure the capscrews are replaced in the same position.
- e. Remove the sixteen hex head capscrews (22) and hex nuts (21) securing shaft coupling flange (16) to reduction gearbox.
- f. Slide shaft coupling flange (16) aft enough on shaft (7) to expose coupling nut (19).
- g. The forward lock bar (20) is tack welded to the coupling nut (19) and will not come off the coupling nut (19).
- h. Using special purpose wrench made from specifications on Sheet 2, remove shaft coupling nut (19, Sheet 1) and lock bar (20) from shaft (7).
- i. Remove socket head capscrew (18) securing shaft coupling machine key (17) to shaft (7), and remove key (17).
- j. Depot maintenance is required to remove propeller (31 or 32) and the propeller cone nut (1), hex nut (2), allen socket set screw (3), cord packing material (4), socket head capscrew (5), and shaft key (6).
- k. Use suitable equipment to remove shaft (7) from vessel, being careful not to damage stern tube and bearing and strut tube and bearing.

## REPAIR

- a. Disassemble stuffing box assembly and replace packing and end plate gasket. Refer to Chapter 3 .
- b. Remove stern tube bearing (33, Sheet 3) as follows:
  - (1) Remove lock wire (35) from four hex head capscrews (36).
  - (2) Loosen four hex head capscrews (36) securing bearing (33) to end plate (37).
  - (3) Remove chock fast orange resin from stern tube void.
  - (4) Remove alignment studs (37A).
  - (5) Remove four hex head capscrews (36) securing bearing (33) to end plate (37).
  - (6) Remove bearing (33) and John Crane zip joint packing (34) from stern tube end plate (37).



**NOTE**

The stern tube bearing (33) is not repairable and should be replaced at routine dockings when the rubber liner shows any signs of wear, pitting or loosened bonding to bearing or when the clearance between the propeller shaft and the bearing is greater than .160 inch or less than .030 inch.

## c. Remove aft strut barrel bearing (39, Sheet 4).

- (1) Remove lock wire (42) from four hex head capscrews (40).
- (2) Loosen four hex head capscrews (40) securing bearing (39) to end plate (38).
- (3) Remove chock fast orange resin from aft strut barrel void.
- (4) Remove alignment studs (37B).
- (5) Remove four hex head capscrews (40) securing bearing (39) to end plate (38).
- (6) Remove bearing (39) and John Crane zip joint packing (41) from strut barrel end plate (38).

**NOTE**

The strut barrel bearing (39) is not repairable and should be replaced at routine dockings when the bearing rubber liner shows any signs of wear, pitting or loosened bonding to bearing or when the clearance between the propeller shaft and the bearing is greater than .160 inch or less than .030 inch.

## d. Remove forward propeller hub bronze bar (45, Sheet 5) and packing material (46) as follows:

**NOTE**

Propeller has been removed by depot maintenance. Shaft key set screw, coupling key and shaft have been previously removed.

- (1) Remove lock wire (43) from six hex head capscrews (44).
- (2) Remove six hex head capscrews (44) securing bronze bar (45) and packing material (46) to propeller hub. Remove bronze bar (45) and packing material (46). Discard packing material.

e. Splice new packing (46, Sheet 5) for propeller hub seal using Loctite kit, as follows:

- (1) Use new packing forming 8 1/2 inch outside diameter with 1/2 inch cord diameter.

**WARNING**

Clean-up solvent contained in the kit contains dimethyl formamide which is toxic. The solvent is provided with the kit for clean-up and is not essential to the splicing procedure. When used, application of the solvent should be done sparingly and limited to areas having exhaust ventilation. Use eye protection and rubber gloves. In case of skin contact, wash with soap and water. In case of eye contact, flush with water and seek medical attention as soon as possible.

- (2) Splicing. Clean razor blade with clean-up solvent, soap and water, or degreasing solvent before each cut. Most razor blades are coated with a film of silicone oil to prevent rusting, which will interfere with good bonding of spliced joints.

**CAUTION**

Ensure the packing material is the correct size as stipulated in paragraph (1). Use sharp razor blade to prevent distortion of the packing ends. Do not touch cut ends, and prevent the ends from becoming contaminated with dirt or grease during handling.

- (a) With one slicing motion of the razor blade, make a single cut in the packing material to avoid jagged edges. Cut the material vertically on the radius, so that the cut end forms an "O."

**WARNING**

Adhesives are eye irritants. In case of accident, flush with water only and seek medical attention as soon as possible. The adhesive bonds strongly and quickly on contact. In case of skin bonding, carefully peel or cut apart contacted areas. Do not pull apart, as adhesive is stronger than skin and will tear skin off. Bond may be softened by soaking in nail polish remover or acetone.

- (b) Apply a small drop of adhesive to one end of the cut cord. If excess is applied, strike cord on a hard surface to shake off excess.
  - (c) Join ends of cord as soon as possible. Position loose ends in splicing fixture alignment guide. Ensure cord is not twisted. Slide ends of cord along guide until ends are in contact. Hold in contact with firm pressure on the bond for 10 to 30 seconds.
  - (d) After 30 seconds of cure, remove adhesive residue from surface of cord by wiping with clean, dry rag or by scraping with smooth plastic or brass tool, using care not to cut or scuff cord surfaces.
  - (e) Allow adhesive to cure 1 hour minimum at room temperature before flexing or stretching.
  - (f) After cure time of 1 hour, flex the cord bonded joint and inspect for lack of bond. If lack of bond is observed, repeat splicing procedures with new packing cord as outlined in steps (2)(a) through (2)(f).
- (3) Waterproof bonded joint. Brush a coating of Loctite waterproofing solution over the bond line. Care should be taken to apply just enough solution to cover the bond line completely around the cord. Prevent air bubbles from forming in the coating, which will make the coating porous.
- (4) Allow coating to cure for 10 minutes. If after 10 minutes the coating is still tacky, the silicone grease that will be applied prior to installation will ensure satisfactory results.
  - (5) Check that the spliced packing properly fits the groove on the bronze bar (46, Sheet 5).
  - (6) Retain packing in safe place to prevent contamination until installation.
- f. Splice new packing (41, Sheet 4) for aft strut barrel bearing (39). Use splicing procedure outlined in paragraph e., using John Crane zip joint packing (41) 5/32 inch diameter.
  - g. Splice new packing (34, Sheet 3) for aft stern tube bearing (33). Use splicing procedure outlined in paragraph e., using John Crane zip joint packing (34) 5/32 inch diameter.
  - h. Clean propeller hub bore (Sheet 5) and bronze bar gland (45) mating surfaces with cleaning solvent and rag. Ensure no dirt particles or other foreign matter is left.
  - i. Clean new bearing (39, Sheet 4) mounting flange, strut barrel and end plate mounting surfaces with solvent and rag. Ensure no dirt particles or other foreign matter is left.
  - j. Clean aft stern tube bearing (33, Sheet 3) mounting flange, end plate (37) and stern tube bore mounting surfaces with solvent and rag. Ensure no dirt particles or other foreign matter is left.

**REPLACEMENT**

- a. Install stern tube bearing (33, Sheet 3) with packing material (34) in stern tube from outside vessel hull.
- b. Install four hex head capscrews (36) and tighten alternately until secure.
- c. Install lock wire (35) into hex head capscrews (36) holes and pigtail lock wire ends.
- d. Install strut barrel bearing (37, Sheet 4) with packing (41) in strut barrel and against end plate (38). Ensure packing (41) is not disturbed.
- e. Install four hex head capscrews (40) and tighten alternately until bearing (39) flange is secure.
- f. Install lock wire (42) through hex head capscrew (40) holes and pigtail ends.
- g. Apply silicone grease to packing (46, Sheet 5) and place packing into groove on bronze bar gland (45).

**NOTE**

At this time, depot maintenance will have installed shaft propeller coupling key and set screw (Sheet 5). The bronze bar gland (45) and packing (46) will have to be installed over the shaft as the shaft is installed.

- h. As shaft (7, Sheet 1) is being installed and prior to entering the barrel, install bronze bar gland (45, Sheet 5) and packing (46) on shaft. As the shaft is being forced into the vessel, the packing (46) will slide along the shaft because of the silicone grease. Clean all silicone grease from shaft as it passes through the packing (46) and bronze gland (45) with solvent.
- i. Guide the shaft (7, Sheet 1) through each bearing (23), being careful not to damage bearings. On the inside of vessel, guide shaft (7) through pilot end plate (12), stuffing box assembly (14), suspended and supported expander tube brake (15) and shaft coupling flange (16), stopping short enough for access to end of shaft to install coupling nut (19), lock bar (20) and coupling key (17).
- j. Install shaft machine coupling key (17) into groove on shaft (7). Secure key (17) with socket head capscrew (18).
- k. Install coupling nut (19) with forward locking bar (20) attached onto shaft threads and secure with special purpose wrench (Sheet 2).
- l. Continue sliding shaft (7, Sheet 1) forward until locking bar (20) mates with coupling on reduction gear box.
- m. Align shaft coupling flange (16) bore groove with shaft machine coupling key (17) and slide coupling flange up to reducing gearbox flange.

- n. Align both flange mounting holes as marked in REMOVAL. Some turning of the shaft might be required.
- o. Install sixteen hex head capscrews (22) into matched holes on coupling flange from aft. Install hex head nuts (21) on forward side of reduction gearbox flange. Tighten hex head capscrews (22) alternately to 350 ft-lb torque.
- p. Depot maintenance is now required to install propeller (31 or 32) along with packing (4), propeller cone nut (1), allen socket set screws (3) and hex nuts (2).
- q. Position bronze gland (45, sheet 5) with packing (46) against propeller hub. Install six hex head capscrews (44) and tighten alternately until secure. Ensure packing (46) remains seated.
- r. Install lock wire (43) through hex head capscrews (44) holes and secure by pigtailling lock wire (43).
- s. At this time shaft alignment should be accomplished by shipyard personnel.
- t. After shaft alignment, install expander tube brake assembly (15, Sheet 1). Refer to Chapter 3 .
- u. Install stuffing box assembly. Refer to Chapter 3 .
- v. Remove chock fast fill plugs and vent plug on top of strut barrel. Fill strut barrel void with chock fast orange resin until vent opening overflows. Clean openings and replace fill and vent plugs. Ensure these plugs are secure.
- w. On the inside of vessel, at aft top end of stern tube, remove chock fast fill and vent plugs. Fill stern tube void with chock fast orange resin until vent plug overflows. Clean overflow from stern tube and replace fill and vent plugs.
- x. If seawater cooling connection was removed from stern tube, reconnect at this time.

**MAINTENANCE OF HULLS/MISCELLANEOUS**

---

**4-24. Replace/Repair Tank Arrangement.**

---

This task covers:

- |              |                 |            |
|--------------|-----------------|------------|
| a. Removal,  | b. Disassembly, | c. Repair, |
| d. Assembly, | e. Replacement. |            |
- 

**INITIAL SETUP:**

Tools

Tool kit, general mechanic's,  
5180-00-699-5273  
Tool kit, welder's,  
5180-00-754-0661  
Torch outfit, cutting and  
welding medium duty,  
oxygen and acetylene,  
3433-00-357-8il6

Equipment Condition

Fuel supply and fill valves closed and  
tank drained, (TM 55-1905-223-10).  
Liquid quantity indicator removed,  
para. 2-273 .  
Welding procedures, TM 55-1900-204-24.

---

**REMOVAL**

Refer to maintenance allocation chart. Code A states that depot level maintenance will be performed on a case by case basis, subject to approval and funding by the NICP.

**SECTION VI. PREPARATION FOR STORAGE OR SHIPMENT.**

4-25. Refer to Section VI., Chapter 2.

**APPENDIX A**

**REFERENCES**

A-1. Scope. This paragraph lists the manuals, bulletins, specifications, and miscellaneous publications referenced in this manual or required for maintenance activities.

A-2. Field Manuals.

FM 21-11	First Aid for Soldiers
FM 31-70	Basic Cold Weather Manual
FM 55-501	Marine Crewman's Handbook

A-3. Technical Manuals.

TM 11-5826-311-12-2-1	Organizational Operation and Maintenance Instructions for the Satellite Signals Navigation Set
TM 11-5826-311-12-2-2	Organizational Operation and Maintenance Instructions For the Satellite Signals Navigation Set
TM 43-0139	Painting Instructions for the Field Use
TM 55-1905-204-24	Arc Welding on Waterborne Vessels
TM 55-1905-223-10	Operator's Manual for Landing Craft, Utility (LCU)
TM 55-1905-223-24-2	Main Reduction Gear Maintenance Manual
TM 55-1905-223-24-18	LCU 2000 Basic Craft Maintenance Manual
TM 55-1905-223-24P	Repair Parts and Special Tools List for the LCU 2000 Class Watercraft
TM 750-244-3	Destruction of Army Materiel to Prevent Enemy Use
TM 55-1905-243-24&P	FM-200 Fire Fighting System

A-4. Technical Bulletins.

TB 43-0144	Painting of Vessels
TB 55-1900-207-24	Treatment of Cooling Water in Marine Diesel Engines
TB 740-97-4	Preservation of Vessels for Storage

A-5. Military Specifications.

MIL-C-16173C	Rust Preventive, Type P-1
MIL-L-644	Preservative Oil, Type P-9
MIL-L-21260	Preservative Oil, Type P-10

A-6. Miscellaneous Publications.

DA Pam 738-750	The Army Maintenance Management System
LO 55-1905-223-12	Lubrication Order for the LCU 2000 Class Watercraft
*AMC-R 750-11	Use of Lubricants, Fluids, and Associated Products



A-7. Forms.

DA Form 2028  
DA Form 2404  
DA Form 2408-16  
DA Form 2410  
SF Form 368

Recommended Changes to Publications and Blank Forms  
Equipment Maintenance and Inspection Worksheet  
Logsheet  
Logsheet  
Quality Deficiency Report

## MAINTENANCE ALLOCATION CHART

### SECTION I. INTRODUCTION

#### 1. General.

This appendix provides a summary of the maintenance operations for Basic Craft. It authorizes categories of maintenance for specific maintenance functions on repairable items and components and the tools and equipment required to perform each function. This appendix may be used as an aid in planning maintenance operations.

#### 2. Maintenance Function.

Maintenance functions will be limited to and defined as follows:

a. Inspect. To determine the serviceability of an item by comparing its physical, mechanical, and/or electrical characteristics with established standards through examination.

b. Test. To verify serviceability and to detect incipient failure by measuring the mechanical or electrical characteristics of an item and comparing those characteristics with prescribed standards.

c. Service. Operations required periodically to keep an item in proper operating condition, i.e., to clean (decontaminate), to preserve, to drain, to paint, or to replenish fuel, lubricants, hydraulic fluids, or compressed air supplies.

d. Adjust. To maintain, within prescribed limits, by bringing into proper or exact position, or by setting the operating characteristics to the specified parameters.

e. Align. To adjust specified variable elements of an item to bring about optimum or desired performance.

f. Calibrate. To determine and cause corrections to be made or to be adjusted on instruments or test measuring and diagnostic equipments used in precision measurement. Consists of comparisons of two instruments, one of which is a certified standard of known accuracy, to detect and adjust any discrepancy in the accuracy of the instrument being compared.

g. Install. The act of emplacing, seating, or fixing into position an item, part, module (component or assembly) in a manner to allow the proper functioning of the equipment or system.

h. Replace. The act of substituting a serviceable like type part, subassembly, or module (component or assembly) for an unserviceable counterpart.

i. Repair. The application of maintenance services (inspect, test, service, adjust, align, calibrate, replace) or other maintenance actions (welding, grinding, riveting, straightening, facing, remachining, or resurfacing) to restore serviceability to an item by correcting specific damage, fault, malfunction, or failure in a part,

subassembly, module (component or assembly), end item, or system.

j. Overhaul. That maintenance effort (service/action) necessary to restore an item to a completely serviceable/operational condition as prescribed by maintenance standards (i.e., DMWR) in appropriate technical publications. Overhaul is normally the highest degree of maintenance performed by the Army. Overhaul does not normally return an item to like new condition.

k. Rebuild. Consists of those services/actions necessary for the restoration of unserviceable equipment of a like new condition in accordance with original manufacturing standards. Rebuild is the highest degree of material maintenance applied to Army equipment. The rebuild operation includes the act of returning to zero those age measurements (hours, miles, etc.) considered in classifying Army equipments/components.

### 3. Column Entries.

a. Column 1, Group Number. Column 1 lists group numbers, the purpose of which is to identify components, assemblies, subassemblies, and modules with the next higher assembly.

b. Column 2, Component/Assembly. Column 2 contains the noun names of components, assemblies, subassemblies, and modules for which maintenance is authorized.

c. Column 3, Maintenance Function. Column 3 lists the functions to be performed on the item listed in column 2. When items are listed without maintenance functions, it is solely for purpose of having the group numbers in the MAC and RPSTL coincide.

d. Column 4, Maintenance Level. Column 4 specifies, by the listing of a "worktime" figure in the appropriate subcolumn(s), the lowest level of maintenance authorized to perform the function listed in column 3. This figure represents the active time required to perform that maintenance function at the indicated level of maintenance. If the number or complexity of the tasks within the listed maintenance function vary at different maintenance levels appropriate "worktime" figures will be shown for each level. The number of task-hours specified by the "worktime" figure represents the average time required to restore an item (assembly, subassembly, component, module, end item or system) to a serviceable condition under typical field operating conditions. This time includes preparation time, troubleshooting time, and quality assurance/quality control time in addition to the time required to perform the specific tasks identified for the maintenance functions authorized in the maintenance allocation chart. Subcolumns of column 4 are as follows:

#### UNIT

- C - Operator/Crew
- O - Organizational

INTERMEDIATE

F - Direct Support  
H - General Support

DEPOT

D - Depot

e. Column 5, Tools and Equipment. Column 5 specifies by code, those common tool sets, (not individual tools) and special tools, test, and support equipment required to perform the designated function.

f. Column 6, Remarks. Column 6 contains an alphabetic code which leads to the remark in Section IV, Remarks, which is pertinent to the item opposite the particular code.

**4. Tool and Test Equipment Requirements (Section III).**

a. Tool or Test Equipment Reference Code. The numbers in this column coincide with the numbers used in the tools and equipment column of the MAC. The numbers indicate the applicable tool or test equipment for the maintenance functions.

b. Maintenance Level. The codes in this column indicate the maintenance level allocated the tool or test equipment.

c. Nomenclature. This column lists the noun name and nomenclature of the tools and test equipment required to perform the maintenance functions.

d. National/NATO Stock Number. This column lists the National/NATO stock number of the specific tool or test equipment.

e. Tool Number. This column lists the manufacturer's part number of the tool followed by the Federal Supply Code for manufacturers (5-digit) in parentheses.

**5. Remarks (Section IV).**

a. Reference Code. This code refers to the appropriate item in Section II, Column 6.

b. Remarks. This column provides the required explanatory information necessary to clarify items appearing in Section II.

SECTION II MAINTENANCE ALLOCATION CHART FOR BASIC CRAFT

(1) GROUP NUMBER	(2) COMPONENT/ ASSEMBLY	(3) MAINTENANCE FUNCTION	(4) MAINTENANCE LEVEL					(5) TOOLS AND EQUIPMENT	(6) REMARKS
			UNIT		INTERMED.		DEPOT		
			C	O	F	H	D		
18	BASIC CRAFT	INSPECT	10.0			20.0			
		TEST	2.0						
		SERVICE	2.0						
		REPLACE				100.0			
		REPAIR	10.0	10.0	40.0	80.0		A	
		OVERHAUL					*	F	
1801	HALON FIREFIGHTING SYSTEM	INSPECT	0.5						
		TEST			1.0				
		SERVICE			1.0			1,3,4	
		REPLACE			5.0			1,2	
		REPAIR			5.0			1,2	
180101	HALON SUBSYSTEM, PAINT LOCKER	INSPECT	0.5						
		TEST			1.0				
		SERVICE			1.0			1,5	
		REPLACE			3.0			1,2	
		REPAIR			3.0			1,2	
180102	HALON SUBSYSTEM,MAIN MACHINERY ROOM	INSPECT	0.5						
		TEST			1.0				
		SERVICE			1.0			1,5	
		REPLACE			3.0			1,2	
		REPAIR			3.0			1,2	

**SECTION III. TOOL AND TEST EQUIPMENT REQUIREMENTS  
FOR  
BASIC CRAFT**

Tool Or Test Eqpt Ref Code	Maint. Level	Nomenclature	National/NATO Stock Number	Tool Number
1	F	Tool kit, general mechanics	5180-00-064-5273	(50980) SC-5180-90 -CL-NO5
2	F	Toot kit, electricians	5180-00-391-1087	(80064) 9000S6202- 73125ALT2
3	F	Weighing scale		(03670) 53711
4	F	Lifting yoke		42432
5	F	Lifting yoke		52829

**SECTION IV. REMARKS**

**BASIC CRAFT**

REFERENCE CODE	REMARKS
A	BASIC CRAFT, GROUP 18 IS LISTED FOR TRACKING INFORMATION ONLY.
B	ALL PIPE AND PIPE FITTINGS ARE NOT SUPPLIED BY VENDOR.
C	ACTUATION CABLE, CO2, TO BE RUN IN 3/8 IN. GALVANIZED PIPE.
D	STEEL CHANNELS AND HARDWARE FOR MOUNTING HALON TANK ARE NOT SUPPLIED BY VENDOR.
E	REPAIR OF THIS ITEM IS BY REPLACEMENT.
F	DEPOT LEVEL REPAIR/MAINTENANCE WILL BE PERFORMED ON A CASE BY CASE BASIS SUBJECT TO APPROVAL AND FUNDING BY THE NATIONAL MAINTENANCE POINT (NMP).

**SECTION II MAINTENANCE ALLOCATION CHART FOR BASIC CRAFT**

(1) GROUP NUMBER	(2) COMPONENT/ ASSEMBLY	(3) MAINTENANCE FUNCTION	(4) MAINTENANCE LEVEL					(5) TOOLS AND EQUIPMENT	(6) REMARKS
			UNIT		INTERMED.		DEPOT		
			C	O	F	H	D		
1802	FURNITRE/FIXTUTRES GROUP	REPLACE REPAIR		1.0 1.0				A A	



**SECTION III. TOOL AND TEST EQUIPMENT REQUIREMENTS  
FOR  
FURNITURE AND FIXTURES**

Tool Or Test Eqpt Ref Code	Maint. Level	Nomenclature	National/NATO Stock Number	Tool Number
1	O	Tool kit, general mechanics	5180-00-699-5273	(50980) SC-5180-90 -CL-NO5

**SECTION IV REMARKS  
FURNITURE AND FIXTURES**

REFERENCE CODE	REMARKS
A	REPAIR OF THIS ITEM IS BY REPIACEMENT.

SECTION II MAINTENANCE ALLOCATION CHART FOR BASIC CRAFT

(1) GROUP NUMBER	(2) COMPONENT/ ASSEMBLY	(3) MAINTENANCE FUNCTION	(4) MAINTENANCE LEVEL					(5) TOOLS AND EQUIPMENT	(6) REMARKS
			UNIT		INTERMED.		DEPOT		
			C	O	F	H	D		
1803	ENTERTAINMENT SYSTEM	REPLACE		1.0				1	A
		REPAIR		1.0				1	A
180301	ANTENNA, OMNI DIRECTIONAL	INSPECT	0.5						
		REPLACE		1.0				1,2	
		REPAIR		1.0				1,2,3	

**SECTION III. TOOL AND TEST EQUIPMENT REQUIREMENTS  
FOR  
ENTERTAINMENT SYSTEM**

Tool Or Test Eqpt Ref Code	Maint. Level	Nomenclature	National/NATO Stock Number	Tool Number
1	O	Toot kit, general mechanics	5180-00-699-5273	(50980) SC-5180-90 -CL-NO5
2	O	Toot kit, electricians	5180-00-391-1087	(80064) 9000S6202- 73125ALT2
3	O	Ohmmeter	6625-00-141-3558	

**SECTION IV REMARKS  
ENTERTAINMENT SYSTEM**

REFERENCE CODE	REMARKS
A	REPAIR OF THIS ITEM IS BY REPIACEMENT.

**SECTION II MAINTENANCE ALLOCATION CHART FOR PURIFIER/SEPARATORS**

(1) GROUP NUMBER	(2) COMPONENT/ ASSEMBLY	(3) MAINTENANCE FUNCTION	(4) MAINTENANCE LEVEL					(5) TOOLS AND EQUIPMENT	(6) REMARKS
			UNIT		INTERMED.		DEPOT		
			C	O	F	H	D		
1804	PURIFIER/SEPARATORS	INSPECT SERVICE REPLACE REPAIR	0.5 2.0		11.0 6.0	8.0		1-6	
180401	PURIFIER,LUBE OIL	INSPECT SERVICE REPLACE REPAIR	0.5 1.0		8.0 2.0	16.5		1,2 1-6	
18040101	MOTOR ASSEMBLY, ELECTRIC	INSPECT REPLACE REPAIR	0.1	1.0	2.0			1 1,9,10	
18040102	PUMP CONNECTION ASSEMBLY	REPLACE REPAIR		1.0 1.0				1 1	
18040103	PUMP, DOUBLE GEAR	REPLACE REPAIR		1.5	4.0			1 1	
18040104	HOOD ASSEMBLY	REPLACE REPAIR		1.5 2.0				1 1	
18040105	BOWL ASSEMBLY	REPLACE REPAIR			1.5	2.5		1,3,4 1,3,4	A A
18040106	VERTICAL GEAR ASSEMBLY	REPLACE REPAIR		1.5		2.0		1,8,9 1	
18040107	HORIZONTAL GEAR ASSEMBLY	REPLACE REPAIR			1.5	2.0		1,6,9 1	
18040108	FRAME ASSEMBLY	REPLACE REPAIR				1.5 2.0		1 1	
18040109	HEATER, CIRCULATION	INSPECT SERVICE REPLACE REPAIR	0.5 0.5		1.0	1.0		1 1,2 1,2	B B
18040110	STRAINER, SEDIMENT	INSPECT SERVICE REPLACE REPAIR	0.5 0.5	1.0 1.0				1 1	

**SECTION II MAINTENANCE ALLOCATION CHART FOR PURIFIER/SEPARATORS**

(1) GROUP NUMBER	(2) COMPONENT/ ASSEMBLY	(3) MAINTENANCE FUNCTION	(4) MAINTENANCE LEVEL					(5) TOOLS AND EQUIPMENT	(6) REMARKS
			UNIT		INTERMED.		DEPOT		
			C	O	F	H	D		
18040111	SWITCH ASSEMBLY, PRESSURE	INSPECT SERVICE REPLACE	0.5 0.5	1.0				1	D
180402	DIESEL FUEL OIL FILTER/ SEPARATOR	INSPECT SERVICE REPLACE REPAIR	0.5 1.0	1.0	1.0	1.5		1,7 1,7	
180403	SEPARATOR, OIL/WATER	INSPECT SERVICE REPLACE REPAIR	1.0 2.0	1.0	8.0 8.0	4.0		1 1 1	
18040301	MOTOR CONTROL BOX ASSEMBLY	REPLACE REPAIR		1.0 0.2	1.0			1,2 1,2	
18040302	GAGE PANEL ASSEMBLY	REPLACE REPAIR		1.0 1.0				1,2 1,2	
18040303	CONTROL MODULE ASSEMBLY (FIRST STAGE)	CALIBRATE REPLACE REPAIR		1.0 1.0		1.0 1,2		1,2,5 1,2	E
18040304	VESSEL SUBASSEMBLY	REPLACE REPAIR	0.5	4.0	4.0			1 1	
18040305	PLATE ASSEMBLY	REPLACE REPAIR			1.0 1.0			1 1	
18040306	VESSEL SUBASSEMBLY (THIRD STAGE)	REPLACE REPAIR		0.5	4.0 4.0			1 1	C C
18040307	VESSEL SUBASSEMBLY (SECOND STAGE)	REPLACE REPAIR		0.5	4.0 4.0			1 1	C C
18040308	PUMP/MOTOR,ASSEMBLY ,OIL	SERVICE REPLACE REPAIR	0.5		1.5	4.0		1 1	
1804030801	PUMP, MOTORIZED	REPLACE REPAIR			1.5	4.0		1 1	

**SECTION II MAINTENANCE ALLOCATION CHART FOR PURIFIER/SEPARATORS**

(1) GROUP NUMBER	(2) COMPONENT/ ASSEMBLY	(3) MAINTENANCE FUNCTION	(4) MAINTENANCE LEVEL					(5) TOOLS AND EQUIPMENT	(6) REMARKS
			UNIT		INTERMED.		DEPOT		
			C	O	F	H	D		
18040309	PUMP/MOTOR,ASSEMBLY, WATER	SERVICE REPLACE REPAIR	0.5		1.5	4.0		1 1	
18040310	SENSING MODULE, ASSEMBLY	CALIBRATE REPLACE REPAIR			1.0	3.0		1 1,2	



**SECTION III. TOOL AND TEST EQUIPMENT REQUIREMENTS  
FOR  
PURIFIER/SEPARATORS**

Tool Or Test Eqpt Ref Code	Maint. Level	Nomenclature	National/NATO Stock Number	Tool Number
1	O,F,H	Toot kit, general mechanics	5180-00-699-5273	(50980) SC-5180-90 I -CL-NO5
2	O,F,H	tool kit, electricians	5180-00-391-1087	(80064) 9000S6202- 73125ALT2
3	F,H	Wrench, annular		(80871) 0003-3997- 000
4	F,H	Wrench, hook		(80871) 0003-3667- 000
5	H	Multimeter	6625-01-139-2519	(80058) AN/PSM-45
6 /i	F	Pressure piece		(80871) 2125-9806- 000
7	O,F	Torque wrench kit		(15434) 3377216
8	F	Gear puller		(15434) 3375016
9	F,H	Arbor press	4920-00-373-9376	
10	H	Bearing putter		(15434) ST-1249

**SECTION IV REMARKS  
PURIFIER/SEPARATORS**

REFERENCE CODE	REMARKS
A	THIS ITEM MUST BE REPLACED BY A MANUFACTURER'S DESIGNATED FACILITY.
B	COMPLETE REPAIR OF THIS ITEM IS BY A MANUFACTURER'S DESIGNATED FACILITY.
C	REPLACE COALESCER ELEMENT AND THE SEPARATOR ELEMENTS AT THE SAME TIME.
D	REPAIR OF THIS ITEM IS BY REPLACEMENT.
E	REPAIR OF THIS ITEM IS BY REPLACEMENT OF LAMPS AND FUSES, COMPLETE REPAIR IS BY
A	MANUFACTURER'S DESIGNATED FACILITY.

**SECTION II MAINTENANCE ALLOCATION CHART FOR BASIC CRAFT**

(1) GROUP NUMBER	(2) COMPONENT/ ASSEMBLY	(3) MAINTENANCE FUNCTION	(4) MAINTENANCE LEVEL					(5) TOOLS AND EQUIPMENT	(6) REMARKS
			UNIT		INTERMED.		DEPOT		
			C	O	F	H	D		
1805	SOUND POWERED TELEPHONE SYSTEM	INSPECT	3.0						B
		TEST			4.0				C
		REPLACE	2.0					1	A,B
180501	TELEPHONE,SOUND POWERED	REPAIR	4.0		8.0			1	A,B
		INSPECT	0.5						B
		TEST			0.5			1	C
180502	TELEPHONE,SOUND POWERED	REPLACE	0.5					1	
		REPAIR	0.5		1.0			1	
		INSPECT	0.5						B
180503	TELEPHONE,SOUND POWERED	TEST			0.5			1	C
		REPLACE	0.5					1	
		REPAIR	0.5		1.0			1	
180504	TELEPHONE,SOUND POWERED	INSPECT	0.5						B
		TEST			0.5			1	C
		REPLACE	0.5					1	
180505	TELEPHONE,SOUND POWERED	REPAIR	0.5		1.0			1	
		INSPECT	0.5						B
		TEST			0.5			1	C
180506	TELEPHONE,SOUND POWERED	REPLACE	0.5					1	
		REPAIR	0.5		1.0			1	
		INSPECT	0.5						B
180507	TELEPHONE,SOWND POWERED	TEST			0.5			1	C
		REPLACE	0.5					1	
		REPAIR	0.5		1.0			1	

**SECTION III. TOOL AND TEST EQUIPMENT REQUIREMENTS  
FOR  
SOUND POWERED TELEPHONE SYSTEM**

Tool Or Test Eqpt Ref Code	Maint. Level	Nomenclature	National/NATO Stock Number	Tool Number
1	C	Toot kit, electricians	5180-00-391-1087	(80064) 9000S6202- 73125ALT2

**SECTION IV REMARKS  
SOUND POWERED TELEPHONE SYSTEM**

REFERENCE CODE	REMARKS
A	NOT REPLACED AS A UNIT, REPLACE BY INDIVIDUAL COMPONENTS ONLY.
B	VISUAL INSPECTION FOR COMPLETENESS FOR MISSING OR BROKEN COMPONENTS.
C	USE MULTIMETER FOR CONTINUITY CHECK.

SECTION II MAINTENANCE ALLOCATION CHART FOR BASIC CRAFT

(1) GROUP NUMBER	(2) COMPONENT/ ASSEMBLY	(3) MAINTENANCE FUNCTION	(4) MAINTENANCE LEVEL					(5) TOOLS AND EQUIPMENT	(6) REMARKS
			UNIT		INTERMED.		DEPOT		
			C	O	F	H	D		
1806	TANK LEVEL INDICATOR SYSTEM	INSPECT REPLACE REPAIR	4.0		6.0 8.0			1 1,3	
180601	INDICATOR,LEVEL SIGHT VLI-86501-44	INSPECT REPLACE REPAIR	0.5		1.0 1.0			1 1,3	
180602	INDICATOR,LEVEL SIGHT VLI-86501-7	INSPECT REPLACE REPAIR	0.5		1.0 1.0			1 1,3	
180603	INDICATOR,LEVEL SIGHT VLI-86501-20	INSPECT REPLACE REPAIR	0.5		1.0 1.0			1 1,3	
180604	INDICATOR,LEVEL SIGHT VLI-86200-36	INSPECT REPLACE REPAIR	0.5		1.0 1.0			1 1	
180605	SWITCH,FLOAT XM-36480-120-1000-O-L	INSPECT REPLACE REPAIR	0.5		1.0 1.0			1 1	
180606	SWITCH,FLOAT XM-36480-112-1000-O-L	INSPECT REPLACE REPAIR	0.5		1.0 1.0			1 1	
180607	SWITCH,FLOAT XM-36480-47-3000-W-L	INSPECT REPLACE REPAIR	0.5		1.0 1.0			1 1	
180608	SWITCH,FLOAT XM-36480-95-1500-O-L	INSPECT REPLACE REPAIR	0.5		1.0 1.0			1 1	
180609	SWITCH,FLOAT XM-36480-125-1000-W-L	INSPECT REPLACE REPAIR	0.5		1.0 1.0			1 1	
180610	SWITCH,FLOAT XM-3660-36-4300-O-L	INSPECT REPLACE REPAIR	0.5		1.0 1.0			1	

SECTION II MAINTENANCE ALLOCATION CHART FOR BASIC CRAFT

(1) GROUP NUMBER	(2) COMPONENT/ ASSEMBLY	(3) MAINTENANCE FUNCTION	(4) MAINTENANCE LEVEL					(5) TOOLS AND EQUIPMENT	(6) REMARKS
			UNIT		INTERMED.		DEPOT		
			C	O	F	H	D		
180611	SWITCH,FLOAT XM-36460-52-2700-O-L	INSPECT	0.5						
		REPLACE			1.0			1	
		REPAIR			1.0			1	
180612	MODULE RECEIVER RE-39240-7JM1-M7-38100	INSPECT	0.5						
		REPLACE			1.0			1	
180613	MODULE RECEIVER RE-39260-12M1-M8-38- 34100/M9-M12-38139	REPAIR	0.5		3.0			1,2	
		INSPECT	0.5						
180614	MODULE RECEIVER RE-31326	REPLACE			1.0			1	
		REPAIR	0.5		3.0			1,2	
180614	MODULE RECEIVER RE-31326	INSPECT	0.5						
		REPLACE			0.5			1	
		REPAIR	0.5		2.0			1,2	

**SECTION III. TOOL AND TEST EQUIPMENT REQUIREMENTS  
FOR  
TANK LEVEL INDICATOR SYSTEM**

Tool Or Test Eqpt Ref Code	Maint. Level	Nomenclature	National/NATO Stock Number	Tool Number
1	C,F	Toot kit, general mechanics	5180-00-699,5273	(50980) SC-5180-90 -CL-N05
2	C	Toot kit, electricians	5180-00-391-1087	
3	F	Torque wrench	5120-01-092-3278	



SECTION II MAINTENANCE ALLOCATION CHART FOR BASIC CRAFT

(1) GROUP NUMBER	(2) COMPONENT/ ASSEMBLY	(3) MAINTENANCE FUNCTION	(4) MAINTENANCE LEVEL					(5) TOOLS AND EQUIPMENT	(6) REMARKS
			UNIT	INTERMED.		DEPOT			
			C	O	F	H	D		
1807	NAVIGATION SIGNAL AND SEARCHLIGHTS	INSPECT	0.5						
		TEST		0.5					
		SERVICE	0.5						
		REPLACE		4.0				1,2,3	
		REPAIR	0.5	1.0	4.0			1,2,3	A-D A-D
180701	LIGHT,NAVIGATION MARINE (FORWARD)	REPLACE		1.0				1	
		REPAIR		1.0				1	
180702	LIGHT,NAVIGATION MARINE (FORWARD)	REPLACE		1.0				1	
		REPAIR		1.0				1	
180703	LIGHT,NAVIGATION MARINE (AFT)	REPLACE		1.0				1	
		REPAIR		1.0				1	
180704	LIGHT,NAVIGATION MARINE	REPLACE		1.0				1	
		REPAIR		1.0				1	
180705	LIGHT,NAVIGATION MARINE	REPLACE		1.0				1	
		REPAIR		1.0				1	
180706	LIGHT,NAVIGATION MARINE (GREEN)	REPLACE		1.0				1	
		REPAIR		1.0				1	
180707	LIGHT,NAVIGATION MARINE (RED)	REPLACE		1.0				1	
		REPAIR		1.0				1	
180708	LIGHT,NAVIGATION MARINE	REPLACE		1.0				1	
		REPAIR		1.0				1	
180709	LIGHT,NAVIGATION MARINE (AFT)	REPLACE		1.0				1	
		REPAIR		1.0				1	
180710	LIGHT,BLINKER	REPLACE		1.0				1	
		REPAIR		1.0				1	
180711	PANEL,INDICATOR	INSPECT	0.5						
		REPLACE		1.0				1	
		REPAIR	0.5	1.0				1,2	
180712	SEARCHLIGHT	INSPECT	0.5						
		TEST			0.5				
		SERVICE	0.5						1,2
		REPLACE			4.0				1,2
		REPAIR			6.0			1,2	A A

SECTION II MAINTENANCE ALLOCATION CHART FOR BASIC CRAFT

(1) GROUP NUMBER	(2) COMPONENT/ ASSEMBLY	(3) MAINTENANCE FUNCTION	(4) MAINTENANCE LEVEL					(5) TOOLS AND EQUIPMENT	(6) REMARKS
			UNIT		INTERMED.	DEPOT			
			C	O	F	H	D		
18071201	DRUM ASSEMBLY	INSPECT REPLACE REPAIR	0.5		1.0 1.0			1,2,3 1,2,3	A A
18071202	STARTER ASSEMBLY	INSPECT TEST REPLACE REPAIR	0.5		0.5 2.0 2.0			1,2 1,2	
18071203	POWER SUPPLY	INSPECT TEST ADJUST REPLACE REPAIR	0.5		1.0 1.4 2.0 2.0			1,2 1,2	
18071204	CONTROL,MANUAL LEVER	INSPECT. SERVICE, REPLACE REPAIR	0.5 0.5		2.0 2.0			1	
18071205	GEAR ASSEMBLY ,LEVEL	INSPECT. REPLACE REPAIR-	0.5		1.0 1.0			1 1	
18071206	CONTROL STATION	INSPECT REPLACE REPAIR,	0.5		1.0 1.0			2 2	
180713	ELECTRICAL HORN-AND. CONTROLS	INSPECT TEST Replace, REPAIR.		0.5 0.1 1.5 2.0				1,2 1,2	D B,C B,C
18071301	HORN,ELECTRICAL	INSPECT TEST REPLACE. REPAIR		0.1 0.5 0.5 1.2				1,2 1,2	D C
18071302	POWER SUPPLY	INSPECT REPLACE REPAIR		0.1 0.5 1.5				1,2 1,2	C C C

**SECTION II MAINTENANCE ALLOCATION CHART FOR NAVIGATIONAL SIGNAL AND SEARCHLIGHTS**

(1) GROUP NUMBER	(2) COMPONENT/ ASSEMBLY	(3) MAINTENANCE FUNCTION	(4) MAINTENANCE LEVEL					(5) TOOLS AND EQUIPMENT	(6) REMARKS
			UNIT		INTERMED.		DEPOT		
			C	O	F	H	D		
18071303	TIMER, SEQUENTIAL	INSPECT		0.1					
		REPLACE		0.3				1,2	
		REPAIR		0.5				1,2	
18071303 01	PANEL ASSEMBLY	INSPECT		0.1					
		REPLACE		0.3					
		REPAIR		1.0					
18071304	SWITCH, ROTARY	INSPECT		0.1					
		REPLACE		0.2				1,2	
		REPAIR		1.8				1,2	
180714	SATELLITE SIGNALS NAVIGATION SET	INSPECT		0.5				1,2	E,G
		REPAIR			4.0				
		REPLACE			5.0				
		TEST			1.0				
18071401	ANTENNA	INSPECT		0.1				1,2	E,G
		REPLACE			5.0				
18071402	ANTENNA AMPLIFIER	INSPECT			0.5			1,2	E,G
		REPLACE			5.0				
18071403	ELECTRICAL EQUIP- MENT MOUNTING BASE MT-6486/SRU	INSPECT		0.1				1,2	E,G
		REPAIR			1.0				
		REPLACE			0.5				
18071404	INDICATOR CONTROL	INSPECT		0.1				1,2	E,G
		REPAIR			2.0				
		REPLACE			1.0				
18071405	RADIO RECEIVER	INSPECT		0.1				1,2	E,F,G
		REPLACE			1.0				
		SERVICE		0.1					
18071406	ELECTRICAL EQUIP- MENT MOUNTING BASE MT-6586/S	INSPECT		0.1				1,2	E,G
		REPLACE			1.0				

**SECTION III. TOOL AND TEST EQUIPMENT REQUIREMENTS FOR  
NAVIGATION SIGNAL AND SEARCHLIGHTS**

Tool Or Test Eqpt Ref Code	Maint. Level	Nomenclature	National/NATO Stock Number	Tool Number
1	C,O,F	Toot kit, general mechanics	518W-00-699-5273	(50980) SC-5180-90 -CL-N05
2	C,O,F	Toot kit, electricians	5180-00-391-1087	(80064) 9000S6202- 73125ALT2
3	F	Wrench, lamp		(28109) 9871

**SECTION IV REMARKS  
NAVIGATION SIGNAL AND SEARCHLIGHTS**

REFERENCE CODE	REMARKS
A	LAMP IS UNDER INTERNAL PRESSURE AND COULD BURST. PROTECT EYES AND BODY WHEN LAMP IS LIT.
B	COMPONENTS OF THIS GROUP/SYSTEM WILL BE ORDERED, REPLACED AND MAINTAINED INDIVIDUALLY.
C	CAUTION: INSURE THAT POLARITY OF POWER CONNECTION IS CORRECT OR DAMAGE TO EQUIPMENT WILL RESULT.
D	TEST FOR SYSTEM OPERATION IN BOTH AUTOMATIC AND MANUAL FUNCTIONS.
E	ALL MAINTENANCE OTHER THAN REPLACEMENT OF MEMORY BATTERIES BT1 THRU BT3 IN THE RADIO SET MUST BE REFERRED TO DIRECT SUPPORT.
F	REPLACE MEMORY BATTERIES BT1 THRU BT3 EVERY 180 DAYS IN ACCORDANCE WITH TM 11-5820-311-12-2-1.
G	<b>Depot maintenance will be performed on a case by case basis subject to approval and funding by the National Maintenance Point (NMP).</b>

**SECTION II MAINTENANCE ALLOCATION CHART FOR MACHINERY SHOP EQUIPMENT**

(1) GROUP NUMBER	(2) COMPONENT/ ASSEMBLY	(3) MAINTENANCE FUNCTION	(4) MAINTENANCE LEVEL					(5) TOOLS AND EQUIPMENT	(6) REMARKS
			UNIT		INTERMED.		DEPOT		
			C	O	F	H	D		
1808	MACHINERY SHOP EQUIPMENT	INSPECT	0.5						
		SERVICE	0.5						
		REPLACE		1.0				1,2	A,B
		REPAIR		1.0	1.5			1,2	A,B
180801	MACHINE,ARC WELDING	INSPECT	0.5						
		SERVICE	0.5						
		REPLACE		1.0				1,2,3	
		REPAIR		1.0	1.5			1,2	
18080101	ELECTRONIC COMPONENT ASSEMBLY	REPLACE			0.5			1	
		REPAIR			1.5			1	
18080102	HIGH FREQUENCY ASSEMBLY	REPLACE			0.5			1	
		REPAIR			1.5			1	
18080103	ELECTRONIC MODULE ASSEMBLY	REPLACE			0.5			1	A,B
		REPAIR	0.5		1.5			1	A,B
1808010301	PRINTED CIRCUIT BOARD (INTERFACE)	REPLACE			0.5			1	
		REPAIR			1.5			1	
1808010302	PRINTED CIRCUIT BOARD (CONTROL)	REPLACE			0.5			1	
		REPAIR			1.5			1	
18080104	FOOT CONTROL, REMOTE	REPLACE		0.2				1,2	
		REPAIR		0.5				1,2	

**SECTION III. TOOL AND TEST EQUIPMENT REQUIREMENTS FOR MACHINERY SHOP EQUIPMENT**

Tool Or Test Eqpt Ref Code	Maint. Level	Nomenclature	National/NATO Stock Number	Tool Number
1	C,O,F	Tool kit, electricians	5180-392-2895	(80064) 9000S6202 73125ALT2
2	C,O	Took kit, general mechanics	5180-00-699-5273	(50980) SC-5180-90 -CL-N05
3	C,O	Lifting sling		(15434) 3375958

**SECTION IV REMARKS  
MACHINERY SHOP EQUIPMENT**

REFERENCE CODE	REMARKS
A	REPAIR IS BY REPLACEMENT OF INDIVIDUAL COMPONENTS.
B	TURN OFF ALL GAS AND POWER CONTROLS AT THE SOURCE, BEFORE REPAIRING EQUIPMENT.

**Change 1      B-32**



**SECTION II MAINTENANCE ALLOCATION CHART FOR COMMISSARY/LAUNDRY**

(1) GROUP NUMBER	(2) COMPONENT/ ASSEMBLY	(3) MAINTENANCE FUNCTION	(4) MAINTENANCE LEVEL					(5) TOOLS AND EQUIPMENT	(6) REMARKS
			UNIT		INTERMED.		DEPOT		
			C	O	F	H	D		
1809	COMMISSARY AND LAUNDRY	INSPECT REPLACE REPAIR	0.2	30.0 3.0	4.0			1-7 1-9	
180901	ELECTRIC RANGE ASSEMBLY	INSPECT REPLACE REPAIR	0.2 1.0	1.5	2.0			1,2 1,2	
180902	GRIDDLE, SELF-HEATING	INSPECT REPLACE REPAIR	0.1	0.5	2.0			1,2 1	
180903	MIXING, MACHINE, FOOD ELECTRIC	INSPECT SERVICE REPLACE REPAIR	0.1 0.1	0.1 1.0	2.5			1 1,2	B
18090301	TRANSMISSION MECHANICAL	REPLACE REPAIR		1.0 0.5	1.5			1 1,8	B
1809030101	INTERMEDIATE SHAFT ASSEMBLY	REPLACE REPAIR		0.5	1.5			1 1	
1809030102	SUN SHAFT GROUP	REPLACE REPAIR		0.5	1.0			1 1	A
1809030103	SHIFTER YOKE ASSEMBLY	REPLACE REPAIR		0.5	1.5			1 1	
1809030104	PINION SHAFT GROUP	REPLACE REPAIR		0.5	1.0			1 1	A
18090302	COLUMN AND BASE ASSEMBLY	REPLACE REPAIR		0.5	1.0			1 1	A
180904	MEAT SLICING MACHINE, ELECTRIC	INSPECT SERVICE REPLACE REPAIR	0.1 0.1	0.2 1.5	2.0			1,2 1,2 1,2	C
18090401	CARRIAGE UNIT ASSEMBLY	REPLACE REPAIR		1.0	1.5			1 1	C

**SECTION II MAINTENANCE ALLOCATION CHART FOR COMMISSARY/LAUNDRY**

(1) GROUP NUMBER	(2) COMPONENT/ ASSEMBLY	(3) MAINTENANCE FUNCTION	(4) MAINTENANCE LEVEL					(5) TOOLS AND EQUIPMENT	(6) REMARKS
			UNIT		INTERMED.		DEPOT		
			C	O	F	H	D		
18090402	KNIFE UNIT ASSEMBLY	REPLACE REPAIR		0.5	1.0			1	
18090403	GAGE PLATE AND INDEXING MECHANISM	REPLACE REPAIR		0.5 0.5	1.0			1 1	
1809040301	GAGE PLATE AND SLIDE ROD ASSEMBLY	REPLACE REPAIR		0.5	0.5			1	
18090404	BASE UNIT ASSEMBLY	REPLACE REPAIR		0.5	0.5			1 1	
18090405	MOTOR PARTS	REPLACE REPAIR		0.5	1.5			1 1	C
18090406	ELECTRICAL UNIT ASSEMBLY	REPLACE REPAIR		0.5	1.5			1,2 1,2	
18090407	KNIFE SHARPENER UNIT ASSEMBLY	REPLACE REPAIR		0.5	0.5			1 1	
180905	REFRIGERATOR, MECHANICAL,FOOD	INSPECT SERVICE REPLACE REPAIR		0.5 0.5 1.0 1.5	2.5			1,2 1,2,3	E,F
18090501	CONDENSER, REFRIGERATION	INSPECT REPLACE REPAIR	0.1	0.5	1.0			1,2,3 1	
18090502	EVAPORATOR COIL, REFRIGERATIDN	INSPECT REPLACE REPAIR		0.1 1.5	1.5			1,2,3	
180906	FREEZER,MECHANICAL, FOOD,	INSPECT SERVICE REPLACE REPAIR		0.1 0.2 1.5 1.5	2.5			1,2 1,2 1,2	E,F
18090601	CONDENSER, REFRIGERATION	INSPECT REPLACE REPAIR	0.1	0.5	1.0.			1,2,3 1	

**SECTION II MAINTENANCE ALLOCATION CHART FOR COMMISSARY/LAUNDRY**

(1) GROUP NUMBER	(2) COMPONENT/ ASSEMBLY	(3) MAINTENANCE FUNCTION	(4) MAINTENANCE LEVEL					(5) TOOLS AND EQUIPMENT	(6) REMARKS
			UNIT		INTERMED.		DEPOT		
			C	O	F	H	D		
18090602	EVAPORATOR COIL, REFRIGERATION	INSPECT REPLACE REPAIR		0.2 1.5		1.5		1,2,3 1,2	
180907	DISPOSAL,GARBAGE (MODIFIED)	INSPECT REPLACE REPAIR	0.1	1.5		2.5		1,2 1,2	D
180908	COMPACTOR,SOLID WASTE	INSPECT SERVICE ADJUST REPLACE REPAIR		0.1 0.2 0.1 1.5		2.5		1,2 1,2	
180909	REFRIGERATOR, MECHANICAL,FOOD	INSPECT SERVICE REPLACE REPAIR		0.1 0.2 1.0 1.0		3.0		1,2 1,2	
18090901	CONDENSER, REFRIGERATION	INSPECT REPLACE REPAIR	0.1	0.5		1.0		1,2,3 1	
18090902	EVAPORATOR COIL, REFRIGERATION	REPLACE REPAIR		1.0		1.5		1,2,3 1,2	
180910	FREEZER,MECHANICAL, FOOD	INSPECT SERVICE REPLACE REPAIR		0.1 0.2 1.5 1.5		2.5		1,2 1,2	E,F
18091001	CONDENSER, REFRIGERATION	INSPECT REPLACE REPAIR	0.1	0.5		1.0		1,2,3 1	
18091002	EVAPORATOR COIL, REFRIGERATION	REPLACE REPAIR		1.5		2.0		1,2,3 1,2	
180911	DISHWASHER	INSPECT SERVICE REPLACE REPAIR		0.1 0.2 1.5		6.0		1,2 1,2	A

**SECTION II MAINTENANCE ALLOCATION CHART FOR COMMISSARY/LAUNDRY**

(1) GROUP NUMBER	(2) COMPONENT/ ASSEMBLY	(3) MAINTENANCE FUNCTION	(4) MAINTENANCE LEVEL					(5) TOOLS AND EQUIPMENT	(6) REMARKS
			UNIT		INTERMED.		DEPOT		
			C	O	F	H	D		
18091101	PUMP AND MOTOR ASSEMBLY	REPLACE REPAIR			1.0 3.5			1 1	
180912	WASHER MACHINE, LAUNDRY COMMERCIAL	INSPECT SERVICE ADJUST REPLACE REPAIR		0.1 0.2 0.1 1.0 1.0				4 1,2 1,2,4-7, 9	
18091201	VALVE,WATER MIXING	REPLACE REPAIR		1.0		1.5		1 1	
18091202	AGITATOR POST ASSEMBLY	REPLACE REPAIR		1.0		1.0		1 1	
18091203	OUTER TUB,COVER AND PRESSURE HOSE GROUP	REPLACE REPAIR		1.0		2.5		1,4	A
18091204	LINT FILTER,WASHTUB AND HUB GROUP	REPLACE REPAIR		1.0		2.5		1,5	A
18091205	BEARING HQWSING, BRAKE/PULLEY AND PIVOT DOME GROUP	REPLACE REPAIR		1.0		2.5		1,6	A
18091206	TRANSMISSION GROUP	INSPECT REPLACE REPAIR		0.5 1.5		2.5		1	A
1809120601	TRANSMISSION, MECHANICAL	REPLACE REPAIR		1.0		2.5		1	A
18091207	PUMP AND HOSES GROUP	REPLACE REPAIR		1.0		2.5		1 1	A
1809120701	PUMP CENTRIFUGAL	REPLACE REPAIR		1.0		1.0		1 1	
18091208	MOTOR AND IDLER GROUP	REPLACE REPAIR		1.0		2.5		1 1	A

SECTION II MAINTENANCE ALLOCATION CHART FOR COMMISSARY/LAUNDRY

(1) GROUP NUMBER	(2) COMPONENT/ ASSEMBLY	(3) MAINTENANCE FUNCTION	(4) MAINTENANCE LEVEL					(5) TOOLS AND EQUIPMENT	(6) REMARKS
			UNIT		INTERMED.		DEPOT		
			C	O	F	H	D		
180913	DRYER TUMBLER, LAUNDRY, COMMERCIAL	INSPECT SERVICE ADJUST REPLACE REPAIR		0.1 0.1 0.1 1.0		4.5		1,2 1,2	
18091301	FRONT BULKHEAD AND CYLINDER ROLLER GROUP	REPLACE REPAIR		1.0		2.0		1 1	A
18091302	REAR BULKHEAD AND CYLINDER ROLLER GROUP	REPLACE REPAIR		1.0		2.0		1 1	A
18091303	HEATER BOX GROUP	REPLACE REPAIR		1.0		2.0		1,2 1,2	A
18091304	MOTOR AND EXHAUST FAN GROUP	REPLACE REPAIR		1.0		2.5		1,2 1,2	A
18091305	CABINET EXHAUST DUCT AND BASE GROUP	REPLACE REPAIR		1.0		2.5		1 1	A

**SECTION III. TOOL AND TEST EQUIPMENT REQUIREMENTS FOR COMMISSARY/LAUNDRY**

Tool Or Test Eqpt Ref Code	Maint. Level	Nomenclature	National/NATO Stock Number	Tool Number
1	O,F	Tool kit, general mechanics	5180-00-699-5273	(50980) SC-5180-90 -CL-N05
2	O,F	Tool kit, electricians	5180-00-391-1087	(80064) 9000S6202- 73125ALT2
3	O	Tool kit refrigeration and air conditioning	5180-00-596-1474	
4	O	Spring hook		(59618) 229P4
5	O	Hex wrench		(59618) 237P4
6	O	Brake spring installer		(59816) 242P4
7	O	Guide spindle		(59618) 230P4
8	F	Arbor press	4920-00-373-9376	230P4
9	F	Tool kit		(59618) 357P3

**SECTION IV REMARKS  
COMMISSARY/LAUNDRY**

REFERENCE CODE	REMARKS
A	REPAIR OF THIS ITEM IS BY REPLACEMENT.
B	AFTER THE FIRST 200 HOURS OF OPERATION AND EVERY 6 MONTHS OR 1000 HOURS OF OPERATION THEREAFTER, THE TRANSMISSION OIL SHOULD BE CHANGED. USE #50 HEAVY DUTY OIL (HYDROL MASTER OR EQUIVALENT - 3 PINTS).
C	FOR FREE CARRIAGE MOTION, LUBRICATE CARRIAGE SLIDE ROD AND BOTTOM FLAT SIDE OF CARRIAGE BAR WITH MOBIL DTE HEAVY MEDIUM OIL (OR EQUIVALENT). DO NOT OIL TOP SIDE OF BAR. NO SERVICE IS REQUIRED FOR MOTOR.
D	ONCE A MONTH, CHECK FOR WEAR OF THE TURNTABLE AND GRIND RING. LOOK FOR WEAR ON THE OUTER EDGE OF TURNTABLE AND IMPACT LUGS. REPLACE IF NECESSARY.
E	PRIOR TO PERFORMING ANY WORK ON THE REFRIGERATION SYSTEM, IT IS REQUIRED-THAT THE UNIT BE DE-ENERGIZED
F	CHECK THE LIQUID REFRIGERANT SIGHT GLASS MONTHLY TO MAKE CERTAIN THAT THE SYSTEM IS FULLY CHARGED

**SECTION II MAINTENANCE ALLOCATION CHART FOR MISCELLANEOUS PUMPS**

(1) GROUP NUMBER	(2) COMPONENT/ ASSEMBLY	(3) MAINTENANCE FUNCTION	(4) MAINTENANCE LEVEL					(5) TOOLS AND EQUIPMENT	(6) REMARKS	
			UNIT		INTERMED.		DEPOT			
			C	O	F	H	D			
1810	MISCELLANEOUS PUMPS/ MOTORS	INSPECT SERVICE REPLACE REPAIR	1.0 1.5 5.0 3.0		5.0				1 1	B
181001	PUMP UNIT,CENTRIFUGAL (FRESH WATER)	INSPECT SERVICE REPLACE REPAIR	0.2 0.2 1.5 1.0			3.0			1 1,3 1-3	
18100101	MOTOR,ALTERNATING CURRENT	INSPECT REPLACE	0.2 1.0						1	A
181002	PUMP UNIT,CENTRIFUGAL (FRESH WATER BOOSTER)	INSPECT SERVICE REPLACE REPAIR	0.2 0.2 1.5 1.0		2.0				1,3 1,3,4	
18100201	MOTOR,ALTERNATING CURRENT	INSPECT REPLACE	0.2 1.0						1	A
181003	PUMP UNIT,CENTRIFUGAL (AUXILIARY SEAWATER COOLING)	INSPECT SERVICE REPLACE REPAIR	0.2 0.2 1.5 1.0		2.0				1,3 1,3,4	
18100301	MOTOR,ELECTRIC	INSPECT REPLACE	0.2 1.0						1	A
* 181004	PUMP UNIT,ROTARY (FUEL OIL TRANSFER) * *	INSPECT SERVICE REPLACE REPAIR	0.2 0.2 1.5 1.0		2.0				1,3 1,3	
18100401	PUMP,ROTARY	INSPECT SERVICE REPLACE REPAIR	0.2 0.2 1.0 1.0		1.5				1 1,2,3	
18100402	MOTOR,ALTERNATING CURRENT	INSPECT REPLACE	0.2 1.0						1	A



**SECTION II MAINTENANCE ALLOCATION CHART FOR MISCELLANEOUS PUMPS**

(1) GROUP NUMBER	(2) COMPONENT/ ASSEMBLY	(3) MAINTENANCE FUNCTION	(4) MAINTENANCE LEVEL					(5) TOOLS AND EQUIPMENT	(6) REMARKS
			UNIT		INTERMED.	DEPOT			
			C	O	F	H	D		
181005	PUMP UNIT,ROTARY (PRELUBE OIL TRANSFER)	INSPECT SERVICE REPLACE REPAIR	0.2 0.2	1.5 1.0	2.0			1,3 1,3	
18100501	PUMP,ROTARY	INSPECT SERVICE REPLACE REPAIR	0.2 0.2	1.0 1.0	1.5			1,3 1-3	
18100502	MOTOR,ALTERNATING CURRENT	INSPECT REPLACE	0.2	1.0				1	A
181006	PUMP UNIT,ROTARY (DIRTY LUBE OIL)	INSPECT SERVICE REPLACE REPAIR	0.2 0.2	1.5 1.0	2.0			1,3 1-3	
18100601	PUMP,ROTARY	INSPECT SERVICE REPLACE REPAIR	0.2 0.2	1.0 1.0	1.5			1,3 1-3	
18100602	MOTOR,ALTERNATING CURRENT	INSPECT REPLACE	0.2	1.0				1	A
181007	PUMP UNIT,CENTRIFUGAL (COOLING WATER, REDUCTION GEAR)	INSPECT SERVICE REPLACE REPAIR	0.2 0.2	1.5 1.0	2.0			1,3 1,3,4	
18100701	MOTOR,ALTERNATING CURRENT	INSPECT REPLACE	0.2	1.0				1,3	A

**SECTION III. TOOL AND TEST EQUIPMENT REQUIREMENTS FOR MISCELLANEOUS PUMPS**

Tool Or Test Eqpt Ref Code	Maint. Level	Nomenclature	National/NATO Stock Number	Tool Number
1	O,F	Tool kit, general mechanics	5180-00-699-5273	(50980) SC-5180-90 -CL-N05
2	F	Wrench, spanner, adjustable		(62321) 7492
3	O,F	Tool kit, electricians	5180-00-391-1087	(80064) 9000S6202- 73125ALT2
4	F	Torque wrench (0-50 ft-lb)	5120-00-242-3264	

**SECTION IV REMARKS**  
**MISCELLANEOUS PUMPS**

REFERENCE CODE	REMARKS
A	REPAIR OF THIS ITEM IS BY REPLACEMENT.
B	DEPOT LEVEL REPAIR/MAINTENANCE WILL BE PERFORMED ON A CASE BY CASE BASIS SUBJECT TO APPROVAL AND FUNDING BY THE NATIONAL MAINTENANCE POINT (NMP).

**Change 4 B-43**

**SECTION II MAINTENANCE ALLOCATION CHART FOR CONTROLS SYSTEMS**

(1) GROUP NUMBER	(2) COMPONENT/ ASSEMBLY	(3) MAINTENANCE FUNCTION	(4) MAINTENANCE LEVEL					(5) TOOLS AND EQUIPMENT	(6) REMARKS
			UNIT		INTERMED.	DEPOT			
			C	O	F	H	D		
1811	CONTROLS SYSTEM	INSPECT		2.0	6.0				
		REPLACE			15.0			1,2	
		REPAIR	4.0	8.0	12.0			1,2	
181101	STEERING CONTROL AND AUTOPILOT SYSTEM	INSPECT			3.0				
		REPLACE			4.0			1	
		REPAIR	1.0		6.0			1	
18110101	PANEL ASSEMBLY STEERING CONTROL	INSPECT			0.5				
		REPLACE			0.5			1	
		REPAIR	0.5		1.5			1	
18110102	AUTOPILOT CONTROL ASSEMBLY	REPLACE			0.5			2	
		REPAIR			0.5			2	
18110103	INDICATOR,RUDDER	INSPECT			0.5				
		REPLACE			0.5			1	
		REPAIR	0.5		1.0			1	
18110104	JUNCTION BOX ASSEMBLY	INSPECT			0.5				
		REPLACE			0.5			1	
		REPAIR	0.5		1.0			1	
18110105	ISOLATION CONTROL UNIT	REPLACE			1.0			2	
		REPAIR			1.0			2	
181102	TWO STATION TWIN ENGINE WITH BOW- THRUSTER AND FIRE CONTROL SYSTEM	INSPECT		2.0					
		REPLACE		10.0				2	
		REPAIR		15.0				2	
18110201	VALVE,ROTARY, DIRECTIONAL CONTROL (CONTROL STATION, PILOT HOUSE)	REPLACE		1.0				2	
		REPAIR		1.5				2	
18110202	CONTROL STATION,ENGINE ROOM	REPLACE		1.0				2	
		REPAIR		1.5				2	
18110203	GEARMATE CONTROL SYSTEM	REPLACE		1.5				2	
		REPAIR		2.5				2	

**SECTION II MAINTENANCE ALLOCATION CHART FOR CONTROLS SYSTEM**

(1) GROUP NUMBER	(2) COMPONENT/ ASSEMBLY	(3) MAINTENANCE FUNCTION	(4) MAINTENANCE LEVEL					(5) TOOLS AND EQUIPMENT	(6) REMARKS
			UNIT		INTERMED.	DEPOT			
			C	O	F	H	D		
1811020301	PANEL,GEARMATE CONTROL	REPLACE		0.5				2	
		REPAIR		1.0				2	
1811020302	THROTTLE INTERLOCK	REPLACE		0.5				2	
		REPAIR		1.0				2	
18110204	GEARMATE CONTROL SYSTEM	REPLACE		1.5				2	
		REPAIR		2.5				2	
1811020401	PANEL,GEARMATE CONTROL	REPLACE		0.5				2	
		REPAIR		1.0				2	
1811020402	THROTTLE INTERLOCK	REPLACE		0.5				2	
		REPAIR		1.0				2	
18110205	AIR PREPARATION SYSTEM	REPLACE		1.0				2	
		REPAIR		1.5				2	
18110206	VALVE REGULATING SYSTEM PRESSURE	REPLACE		1.0				2	
		REPAIR		2.0				2	
18110207	GOVERNOR ACTUATOR ASSEMBLY	REPLACE		0.5				2	
		REPAIR		1.0				2	
1811020701	MANUAL OVER-RIDE GOVERNOR ACTUATOR	REPLACE		0.5				2	
		REPAIR		1.0				2	
18110208	VALVE,LINEAR DIRECTIONAL CONTROL	REPLACE		0.5				2	
		REPAIR		1.0				2	
18110209	BOWTHRUSTER/FIRE PUMP VALVE SYSTEM	REPLACE		0.5				2	
		REPAIR		1.0				2	
1811020901	CYLINDER ASSEMBLY	REPLACE		1.0				2	
		REPAIR		2.0				2	
181103	MACHINERY PLANT MONITORING AND ALARM SYSTEM	INSPECT			6.0			1	
		REPLACE			10.0			1	
		REPAIR	8.0		16.0			1	
18110301	PANEL ASSEMBLY, ENGINE ROOM	INSPECT			0.5			1	
		REPLACE			0.5			1	
		REPAIR	0.5		1.0			1	

**SECTION II MAINTENANCE ALLOCATION CHART FOR CONTROLS SYSTEM**

(1) GROUP NUMBER	(2) COMPONENT/ ASSEMBLY	(3) MAINTENANCE FUNCTION	(4) MAINTENANCE LEVEL					(5) TOOLS AND EQUIPMENT	(6) REMARKS
			UNIT		INTERMED.	DEPOT			
			C	O	F	H	D		
18110302	MULTI-REMOTE MODULE, ENGINE ROOM	INSPECT			0.5				
		REPLACE			0.5			1	
		REPAIR	1.0		2.0			1	
18110303	REMOTE MODULE,PORT ENGINE	INSPECT			0.5				
		REPLACE			0.5			1	
		REPAIR	1.0		2.0			1	
18110304	PANEL,ANNUNCIATOR, ENGINEERS QUARTERS	INSPECT			0.5				
		REPLACE			0.5			1	
		REPAIR	0.5		1.0			1	
18110305	PANEL,ANNUNCIATOR GALLEY	INSPECT			0.5				
		REPLACE			0.5			1	
		REPAIR	0.5		1.0			1	
18110306	INTERFACE UNIT ASSEMBLY	REPLACE	0.5					1	
		REPAIR		1.0				1	
18110307	REMOTE MODULE STARBOARD ENGINE	INSPECT			0.5				
		REPLACE			0.5			1	
		REPAIR	1.0		2.0			1	
18110308	INTERFACE UNIT ASSEMBLY	REPLACE	0.5					1	
		REPAIR		1.0				1	
18110309	PANEL ASSEMBLY, BRIDGE	INSPECT			0.5				
		REPLACE			0.5			1	
		REPAIR	0.5		1.0			1	
18110310	CENTRAL PROCESSING UNIT	INSPECT			0.5				
		REPLACE			0.5			1	
		REPAIR	0.5		1.0			1	
18110311	ANALOG REMOTE MODULE ASSEMBLY	INSPECT			1.0				
		REPLACE			1.0			1	
		REPAIR	1.0		3.0			1	
18110312	REMOTE MODULE, GENERATORS	INSPECT			0.5				
		REPLACE			0.5			1	
		REPAIR	1.0		2.0			1	

**SECTION II MAINTENANCE ALLOCATION CHART FOR CONTROLS SYSTEM**

(1) GROUP NUMBER	(2) COMPONENT/ ASSEMBLY	(3) MAINTENANCE FUNCTION	(4) MAINTENANCE LEVEL					(5) TOOLS AND EQUIPMENT	(6) REMARKS
			UNIT		INTERMED.		DEPOT		
			C	O	F	H	D		
18110313	INTERFACE UNIT ASSEMBLY	REPLACE REPAIR			0.5 1.0			1	
18110314	INTERFACE UNIT ASSEMBLY	REPLACE REPAIR	0.5		0.5 1.0			1 1	
18110315	INTERFACE UNIT ASSEMBLY	REPLACE REPAIR			0.5 1.0			1 1	
18110316	MULTI-REMOTE MODULE, MOTOR CONTROLLERS	INSPECT REPLACE REPAIR			0.5 0.5 2.0			1 1 1	
181104	ENGINE ORDER TELEGRAPH SYSTEM	INSPECT REPLACE REPAIR			2.0 2.5 5.0			1 1	
18110401	PANEL ASSEMBLY, BRIDGE	INSPECT REPLACE REPAIR			0.5 0.5 2.0			1 1	
18110402	MULTI-REMOTE MODULE, BRIDGE	REPLACE REPAIR			0.5 1.0			1 1	
18110403	CENTRAL PROCESSING UNIT	INSPECT REPLACE REPAIR			0.5 0.5 1.0			1 1	
18110404	MULTI-REMOTE MODULE ENGINE ROOM	INSPECT REPLACE REPAIR			1.5 1.5 3.0			1 1	
18110405	PANEL ASSEMBLY, ENGINE ROOM	INSPECT REPLACE REPAIR			0.5 0.5 2.0			1 1	
181105	BOW RAMP CONTROL SYSTEM	INSPECT REPLACE REPAIR			1.5 1.5 3.0			1 1	
18110501	PANEL, CONTROL (WINCH ROOM)	INSPECT REPLACE REPAIR			0.5 0.5 1.0			1 1	

**SECTION II MAINTENANCE ALLOCATION CHART FOR CONTROLS SYSTEM**

(1) GROUP NUMBER	(2) COMPONENT/ ASSEMBLY	(3) MAINTENANCE FUNCTION	(4) MAINTENANCE LEVEL					(5) TOOLS AND EQUIPMENT	(6) REMARKS
			UNIT		INTERMED.	DEPOT			
			C	O	F	H	D		
18110502	PANEL,CONTROL (PILOTHOUSE)	INSPECT		0.5					
		REPLACE		0.5				1	
		REPAIR	0.5	1.0				1	
18110503	PANEL,CONTROL (FORCASTLE)	INSPECT		0.5					
		REPLACE		0.5				1	
		REPAIR	0.5	1.0				1	
181106	FIRE DETECTION SYSTEM	INSPECT			2.0				
		REPLACE			1.0			1	
		REPAIR		2.0	3.0			1	
18110601	CONTROL PANEL,FIRE DETECTION WITH THERMOSTATS	INSPECT			1.0				
		REPLACE			0.5			1	
		REPAIR	1.0	2.0				1	
18110602	PANEL,ALARM, SHIPBOARD	INSPECT			0.5				
		REPLACE			0.5			1	
		REPAIR		0.5	1.0			1	
181107	BOWTHRUSTER CONTROL SYSTEM	INSPECT		1.0					
		REPLACE		1.0				1	
		REPAIR	1.0	3.0				1	
18110701	PANEL ASSEMBLY, STEERING CONTROL	INSPECT		0.5					
		REPLACE		0.5				1	
		REPAIR	0.5	1.0				1	
18110702	CONTROL UNIT ASSEMBLY,BOW- THRUSTER	INSPECT		0.5					
		REPLACE		0.5				1	
		REPAIR	1.0	1.0				1	



**SECTION III. TOOL AND TEST EQUIPMENT REQUIREMENTS FOR ELECTRICAL SYSTEM**

Tool Or Test Eqpt Ref Code	Maint. Level	Nomenclature	National/NATO Stock Number	Tool Number
1	O,F	Tool kit, electricians	5180-00-391-1087	(80064) 9000S6504- 73721
2	O,F	Tool kit, general mechanics	5180-00-699-5273	SC-5180-90 -CL-N05

**SECTION IV REMARKS  
CONTROLS SYSTEM**

REFERENCE CODE	REMARKS
A	REPAIR OF THIS ITEM IS BY REPLACEMENT.
B	REPAIR FOR THIS ITEM IS INCLUDED I.N REPAIR KIT FOR TOP ASSEMBLY.

**Change 1 B-50**

**SECTION II MAINTENANCE ALLOCATION CHART FOR ELECTRICAL SYSTEM**

(1) GROUP NUMBER	(2) COMPONENT/ ASSEMBLY	(3) MAINTENANCE FUNCTION	(4) MAINTENANCE LEVEL					(5) TOOLS AND EQUIPMENT	(6) REMARKS
			UNIT		INTERMED.		DEPOT		
			C	O	F	H	D		
1812	ELECTRICAL SYSTEM	INSECT	1.0						
		REPLACE REPAIR	1.0	2.0	2.0	2.0		1 1	
181201	POWER DISTRIBUTION (240V)	INSPECT	1.0						
		REPLACE REPAIR	1.0	2.0	2.0			1 1	
18120101	POWER,SHORE SUPPLY ASSEMBLY	INSPECT	0.2						
		REPLACE REPAIR	1.0	0.5				1 1	
18120102	PANEL,POWER DISTRIBUTION P201	INSPECT	0.2						
		REPLACE REPAIR	1.0	1.5	1.5			1 1	
1812010201	DOOR ASSEMBLY	REPLACE		0.5					
		REPAIR		0.5				1 1	
1812010202	BREAKER PLUG IN UNIT	REPLACE		0.5					
		REPAIR		0.5				1 1	
1812010203	LUG,MAIN INTERIOR	REPLACE		0.5					
		REPAIR		0.5				1 1	
18120103	PANEL,POWER DISTRIBUTION GALLEY (P202)	INSPECT	0.2						
		REPLACE REPAIR	1.0	1.5	1.5			1 1	
1812010301	DOOR ASSEMBLY	REPLACE		0.5					
		REPAIR		0.5				1 1	
1812010302	BREAKER,PLUG IN UNIT	REPLACE		0.5					
		REPAIR		0.5				1 1	
1812010303	LUG,MAIN INTERIOR	REPLACE		0.5					
		REPAIR		0.5				1 1	
1812010304	SWITCH, DISCONNECT	REPLACE		1.0					
		REPAIR		1.0				1 1	

**SECTION II MAINTENANCE ALLOCATION CHART FOR ELECTRICAL SYSTEM**

(1) GROUP NUMBER	(2) COMPONENT/ ASSEMBLY	(3) MAINTENANCE FUNCTION	(4) MAINTENANCE LEVEL					(5) TOOLS AND EQUIPMENT	(6) REMARKS
			UNIT						
			C	O	F	H	D		
1812010305	SWITCH, DISCONNECT	REPLACE REPAIR		1.0 1.0				1 1	
18120104	PANEL,POWER DISTRIBUTION (P203)	INSPECT REPLACE REPAIR	0.2 1.0	1.5 1.5	1.5			1 1	
1812010401	DOOR ASSEMBLY	REPLACE REPAIR	1.0	0.5 0.5				1 1	
1812010402	BREAKER,PLUG IN UNIT	REPLACE REPAIR		0.5 0.5				1 1	
1812010403	LUG,MAIN INTERIOR	REPLACE REPAIR		0.5 0.5				1 1	
18120105	PANEL,POWER DISTRIBUTION (P204)	INSPECT REPLACE REPAIR	0.2 1.0	1.5 1.5	1.5			1 1	
1812010501	DOOR ASSEMBLY	REPLACE REPAIR		0.5 0.5				1 1	
1812010502	BREAKER,PLUG IN UNIT	REPLACE REPAIR		0.5 0.5				1 1	
1812010503	LUG,MAIN INTERIOR	REPLACE REPAIR		0.5 0.5				1 1	
18120106	AUXILLIARY MACHINERY MOTOR CONROL CENTER POWER DISTRIBUTION	INSPECT REPLACE REPAIR	0.2 1.0	1.5	2.0 2.0			1 1	
18120107	FOWARD DECK MACHINERY MOTOR CONTROL CENTER POWER DISTRIBUTION	INSPECT REPLACE REPAIR	0.2 1.0	1.5	1.0 1.0			1 1	
18120108	FIRE PUMP NUMBER TWO POWER DISTRIBUTION REPAIR	INSPECT REPLACE	0.2 1.0		1.0 1.0			1 1	

**SECTION II MAINTENANCE ALLOCATION CHART FOR ELECTRICAL SYSTEM**

(1) GROUP NUMBER	(2) COMPONENT/ ASSEMBLY	(3) MAINTENANCE FUNCTION	(4) MAINTENANCE LEVEL					(5) TOOLS AND EQUIPMENT	(6) REMARKS
			UNIT		INTERMED.	DEPOT			
			C	O	F	H	D		
18120109	ENGINE ROOM VENT MOTOR CONTROL CENTER POWER DISTRIBUTION	INSPECT	0.2						
		REPLACE REPAIR	1.0		2.0 2.0			1 1	
18120110	PANEL,POWER DISTRIBUTION (P211)	INSPECT	0.2						
		REPLACE REPAIR	1.0	1.5 1.5				1 1	
1812011001	DOOR ASSEMBLY	REPLACE		0.5					1
		REPAIR		0.5					1
1812011002	BREAKER,PLUG IN UNIT	REPLACE		0.5					1
		REPAIR		0.5					1
1812011003	LUG,MAIN INTERIOR	REPLACE		0.5					1
		REPAIR		0.5					1
18120111	PILOT HOWSE AIR CONDITION POWER DISTRIBUTION	INSPECT	0.2						
		REPLACE REPAIR	1.0		1.5 1.5			1 1	
18120112	ACCOMMODATION AIR CONDITION POWER DISTRIBUTION	INSPECT	0.2						
		REPLACE REPAIR			1.5 1.5			1 1	
18120113	ENGINE ROOM AIR CONDITION POWER DISTRIBUTION	INSPECT	0.2						
		REPLACE REPAIR	1.0		1.5 1.5			1 1	
18120114	WATER HEATER POWER DISTRIBUTION	INSPECT	0.2						
		REPLACE REPAIR		1.5 1.5				1 1	
1812011401	SWITCH,DISCONNECT	REPLACE		1.0					1
		REPAIR		1.0					1
18120115	PUMP,FRESH WATER NUMBER1 POWER DISTRIBUTION	INSPECT	0.2						
		REPLACE REPAIR		1.5 1.5				1 1	
18120116	PUMP,FRESH WATER NUMBER 2 POWER DISTRIBUTION	INSPECT	0.2						
		REPLACE REPAIR		1.5 1.5				1 1	

**SECTION II MAINTENANCE ALLOCATION CHART FOR ELECTRICAL SYSTEM**

(1) GROUP NUMBER	(2) COMPONENT/ ASSEMBLY	(3) MAINTENANCE FUNCTION	(4) MAINTENANCE LEVEL					(5) TOOLS AND EQUIPMENT	(6) REMARKS
			UNIT		INTERMED.	DEPOT			
			C	O	F	H	D		
18120117	WINCH,STERN ANCHOR POWER DISTRIBUTION	INSPECT REPLACE REPAIR	0.2	1.5	1.5			1 1	
18120118	DAVIT,BOAT POWER DISTRIBUTION	INSPECT REPLACE REPAIR	0.2	1.5	1.5			1 1	
18120119	PUMP,BILGE/BALLAST POWER DISTRIBUTION	INSPECT REPLACE REPAIR	0.2	1.5	1.5			1 1	
18120120	WELDER POWER DISTRIBUTION	INSPECT REPLACE REPAIR	0.2	1.5	1.5			1 1	
1812012001	SWITCH,DISCONNECT	REPLACE REPAIR		1.5	1.0			1 1	
18120121	STEERING GEAR PORT POWER DISTRIBUTION	INSPECT REPLACE REPAIR	0.2		1.5 1.5			1	
18120122	FIRE PUMP NUMBER 1 POWER DISTRIBUTION	INSPECT REPLACE REPAIR	0.2 1.0	1.5	1.5			1 1	
18120123	WINCH,BOW RAMP POWER DISTRIBUTION) (P226	INSPECT REPLACE REPAIR	0.2		1.5 1.5			1 1	
181202	POWER DISTRIBUTION 120V	INSPECT REPLACE REPAIR	0.2	1.5	1.5			1 1	
18120201	PANEL,POWER DISTRIBUTION P101	INSPECT REPLACE REPAIR	0.2 0.5	1.5 1.0	1.5			1 1	
1812020101	DOOR ASSEMBLY	REPLACE REPAIR		0.5 0.5				1	

**SECTION II MAINTENANCE ALLOCATION CHART FOR ELECTRICAL SYSTEM**

(1) GROUP NUMBER	(2) COMPONENT/ ASSEMBLY	(3) MAINTENANCE FUNCTION	(4) MAINTENANCE LEVEL					(5) TOOLS AND EQUIPMENT	(6) REMARKS
			UNIT		INTERMED. F	DEPOT H	D		
			C	O					
1812020102	BREAKER,PLUG IN UNIT	REPLACE REPAIR		0.5 0.5				1 1	
1812020103	LUG,MAIN INTERIOR	REPLACE REPAIR		0.5 0.5				1 1	
18120202	PANEL,POWER DISTRIBUTION (LI02)	INSPECT REPLACE REPAIR	0.2 0.2	1.5 1.0	1.5			1 1	
1812020201	DOOR ASSEMBLY	REPLACE REPAIR		0.5 0.5				1 1	
1812020202	BREAKER,PLUG IN UNIT	REPLACE REPAIR		0.5 0.5				1 1	
1812020203	LUG,MAIN INTERIOR	REPLACE REPAIR		0.5 0.5				1 1	
18120203	PANEL,POWER DISTRIBUTION (L104)	INSPECT REPLACE REPAIR	0.2	1.5	1.5			1 1	
1812020301	DOOR ASSEMBLY	REPLACE REPAIR		0.5 0.5				1 1	
1812020302	BREAKER,PLUG IN UNIT	REPLACE REPAIR		0.5 0.5				1 1	
1812020303	LUG,MAIN INTERIOR	REPLACE REPAIR		0.5 0.5				1 1	
18120204	PANEL,POWER DISTRIBUTION (L105)	INSPECT REPLACE REPAIR	0.2 0.2	1.5 1.5	1.5			1 1	
1812020401	DOOR ASSEMBLY	REPLACE REPAIR	0.2	0.5 0.5				1 1	
1812020402	BREAKER,PLUG IN UNIT	REPLACE REPAIR		0.5 0.5				1 1	

**SECTION II MAINTENANCE ALLOCATION CHART FOR ELECTRICAL SYSTEM**

(1) GROUP NUMBER	(2) COMPONENT/ ASSEMBLY	(3) MAINTENANCE FUNCTION	(4) MAINTENANCE LEVEL					(5) TOOLS AND EQUIPMENT	(6) REMARKS
			UNIT		INTERMED.		DEPOT		
			C	O	F	H	D		
1812020403	LUG MAIN INTERIOR	REPLACE REPAIR		0.5 0.5				1 1	
1812020404	FLOODLIGHT	REPLACE REPAIR		1.5	1.5			1 1	
1812020405	FLOODLIGHT	REPLACE REPAIR		1.5	1.5			1 1	
18120205	PANEL,POWER DISTRIBUTION (PI06)	INSPECT REPLACE REPAIR	0.2	1.5 1.5	1.5			1 1 1	
1812020501	DOOR ASSEMBLY	REPLACE REPAIR		0.5 0.5				1 1	
1812020502	'BREAKER,PLUG IN UNIT	REPLACE REPAIR		0.5 0.5				1 1	
1812020503	LUG,MAIN INTERIOR	REPLACE REPAIR		0.5 0.5				1 1	
181203	POWER DISTRIBUTION 240V EMERGENCY	INSPECT REPLACE REPAIR	0.2	1.5 1.5	1.5			1 1	
181204	POWER DISTRIBUTION 120V EMERGENCY	INSPECT REPLACE REPAIR	0.2	1.5 1.5	1.5			1 1	
18120401	PANEL,POWER DISTRIBUTION (EL102)	INSPECT REPLACE REPAIR	0.2	1.5 1.5	1.5			1 1	
1812040101	DOOR ASSEMBLY	REPLACE REPAIR		0.5 0.5				1 1	
1812040102	BREAKER,PLUG IN UNIT	REPLACE REPAIR		0.5 0.5					
1812040103	LUG MAIN INTERIOR	REPLACE REPAIR		0.5 0.5				1 1	



**SECTION II MAINTENANCE ALLOCATION CHART FOR ELECTRICAL SYSTEM**

(1) GROUP NUMBER	(2) COMPONENT/ ASSEMBLY	(3) MAINTENANCE FUNCTION	(4) MAINTENANCE LEVEL					(5) TOOLS AND EQUIPMENT	(6) REMARKS
			UNIT		INTERMED.		DEPOT		
			C	O	F	H	D		
1812040104	FLOODLIGHT	REPLACE REPAIR		1.5				1 1	
18120402	PANEL,POWER DISTRIBUTION (EP103)	INSPECT REPLACE REPAIR	0.2 0.2	1.5 1.5	1.5			1 1	
1812040201	DOOR ASSEMBLY	REPLACE REPAIR		0.5 0.2				1 1	
1812040202	BREAKER,PLUG IN UNIT	REPLACE REPAIR		0.5 0.5				1 1	
1812040203	LUG,MAIN INTERIOR	REPLACE REPAIR		0.5 0.5				1 1	
181205	EMERGENCY POWER LIGHTING	REPLACE REPAIR		1.0	1.0			1 1	
181206	POWER,DISTRIBUTION 24VDC EMERGENCY REPAIR	INSPECT REPLACE REPAIR	0.2	1.5 1.5	1.5			1 1	
18120601	PANEL,POWER DISTRIBUTION (EP024-1)	INSPECT REPLACE REPAIR	0.2	1.5	1.5			1 1	
18120602	PANEL,POWER DISTRIBUTION (EP024 SECT B)	INSPECT REPLACE REPAIR	0.2	1.5 1.5	1.5			1 1	
181207	BATTERY,STORAGE GROUP	INSPECT SERVICE REPLACE REPAIR	0.2 2.0 0.2	1.0 1.0	1.0			1 1 1	
18120701	BATTERY,EMERGENCY SWITCHBOARD ASSEMBLY	INSPECT SERVICE REPLACE REPAIR	0.2 1.0 0.2	1.5	1.0 1.5			1 1 1	

**SECTION II MAINTENANCE ALLOCATION CHART FOR ELECTRICAL SYSTEM**

(1) GROUP NUMBER	(2) COMPONENT/ ASSEMBLY	(3) MAINTENANCE FUNCTION	(4) MAINTENANCE LEVEL					(5) TOOLS AND EQUIPMENT	(6) REMARKS
			UNIT		INTERMED.		DEPOT		
			C	O	F	H	D		
1812070101	CHARGER,BATTERY	REPLACE		1.0				1	
		REPAIR	0.2	1.0	1.0			1	
18120702	BATTERY,PILOT HOUSE ASSEMBLY	INSPECT	0.2						
		SERVICE	1.0					1	
		REPLACE		1.0				1	
1812070201	CHARGER,BATTERY	REPAIR	1.0	1.0	1.0			1	
		INSPECT	0.2						
18120703	BATTERY,ASSEMBLY, EMERGENCY GENERATOR	REPLACE		1.0				1	
		SERVICE	1.0					1	
		REPAIR	0.2	1.0	1.0			1	
1812070301	CHARGER,BATTERY	INSPECT	0.2						
		REPLACE		1.0				1	
18120704	BATTERY,GENERATOR NUMBER ONE,ASSEMBLY	REPAIR	0.2	1.0	1.0			1	
		INSPECT	0.2						
		SERVICE	1.0					1	
1812070401	CHARGER,BATTERY	REPLACE		1.0				1	
		REPAIR	0.2	1.0	1.0			1	
18120705	BATTERY,BOW THRUSTER ASSEMBLY	INSPECT	0.2						
		SERVICE	1.0					1	
		REPLACE		1.0				1	
1812070501	CHARGER,BATTERY	REPAIR	1.0		1.0			1	
		REPLACE	0.2	1.0	1.0			1	

**SECTION III. TOOL AND TEST EQUIPMENT REQUIREMENTS  
FOR  
ELECTRICAL SYSTEM**

Tool Or Test Eqpt Ref Code	Maint. Level	Nomenclature	National/NATO Stock Number	Tool Number
1	C,O,F	Tool kit, electricians	5180-00-391-1087	(80064) 9000S6202- 73125ALT2

**SECTION II MAINTENANCE ALLOCATION CHART FOR DOORS, HATCHES, AND  
MANHOLES/WINDOWS GROUP**

(1) GROUP NUMBER	(2) COMPONENT/ ASSEMBLY	(3) MAINTENANCE FUNCTION	(4) MAINTENANCE LEVEL					(5) TOOLS AND EQUIPMENT	(6) REMARKS
			UNIT		INTERMED.		DEPOT		
			C	O	F	H	D		
1813	DOORS,HATCHES AND MANHOLES/WINDOWS GROUP	INSPECT		2.0					
		SERVICE		1.0					
		REPLACE		24.0				1,2,3	
		REPAIR		24.0	12.0			1,2,3	
181301	DOOR,WATERTIGHT	INSPECT		0.2					
		REPLACE		1.0				1,2,3	
		REPAIR		1.5	1.0			1,2,3	
181302	DOOR,WATERTIGHT	INSPECT		0.2					
		REPLACE		1.0				1,2,3	
		REPAIR		1.5	1.0			1,2,3	
181303	DOOR,WATERTIGHT	INSPECT		0.2					
		REPLACE		1.0				1,2,3	
		REPAIR		1.5	1.0			1,2,3	
181304	DOOR,WATERTIGHT (QUICK ACTION,LEFT HAND)	INSPECT		0.2					
		REPLACE		1.0				1,2,3	
		REPAIR		1.5	1.0			1,2,3	
181305	DOOR,WATERTIGHT	INSPECT		0.2					
		REPLACE		1.0				1,2,3	
		REPAIR		1.5	1.0			1,2,3	
181306	DOOR,WATERTIGHT	INSPECT		0.2					
		REPLACE		1.0				1,2,3	
		REPAIR		1.5	1.0			1,2,3	
181307	DOOR,WATERTIGHT	INSPECT		0.2					
		REPLACE		1.0				1,2,3	
		REPAIR		1.5	1.0			1,2,3	
181308	HATCH,WATERTIGHT (QUICK ACTION) REPAIR	INSPECT		0.2					
		REPLACE		1.0				1,2,3	
		REPAIR		1.5	1.0			1,2,3	
181309	SCUTTLE,WATERTIGHT (QUICK ACTION,FLUSH)	INSPECT		0.2					
		REPLACE		1.0				1,2,3	
		REPAIR		2.5	1.0			1,2,3	

**SECTION II MAINTENANCE ALLOCATION CHART FOR  
DOORS, HATCHES AND MANHOLES/WINDOWS GROUP**

(1) GROUP NUMBER	(2) COMPONENT/ ASSEMBLY	(3) MAINTENANCE FUNCTION	(4) MAINTENANCE LEVEL					(5) TOOLS AND EQUIPMENT	(6) REMARKS
			UNIT		INTERMED.		DEPOT		
			C	O	F	H	D		
181310	SCUTTLE,WATERTIGHT (QUICK ACTION,RAISED)	INSPECT		0.2					
		REPLACE		1.0				1,2,3	
		REPAIR		2.5	1.0			1,2,3	
181311	WINDOW,FIXED (HEAT TREATED)	REPLACE			1.0			1	
		REPAIR			1.0			1	
181312	WINDOW,FIXED (WIRE INSERT)	REPLACE			1.0				
		REPAIR			1.0				
181313	WINDOW,FIXED (WITH ROTARY WINDOW)	INSPECT		0.2					
		REPLACE			1.0			1,4	
		REPAIR			1.0			1,4	
18131301	WINDOW,ROTARY	REPLACE			1.0			1	
		REPAIR			1.0			1	
181314	WINDOW,FIXED (RIGHT HAND)	REPLACE			1.0			1	
		REPAIR			1.0			1	
181315	WINDOW,FIXED (LEFT HAND)	REPLACE			1.0			1	
		REPAIR			1.0			1	
181316	WINDOW,FIXED	REPLACE			1.0			1	
		REPAIR			1.0			1	

**SECTION III. TOOL AND TEST EQUIPMENT REQUIREMENTS  
FOR  
DOORS, HATCHES, AND MANHOLES/WINDOWS GROUP**

Tool Or Test Eqpt Ref Code	Maint. Level	Nomenclature	National/NATO Stock Number	Tool Number
1	O,F	Tool kit, general mechanics	5180-00-699-5273	(50980) SC5180-90- CL-N05
2	O,F	Torch, cutting and welding	3433-00-357-8116	
3	O,F	Tool kit, welder	5180-00-754-0661	
4	F	Tool kit, electricians	5180-00-391-1087	(80064) 9000S6202- 73125ALT2

SECTION II MAINTENANCE ALLOCATION CHART FOR LASHING GEAR EQUIPMENT

(1) GROUP NUMBER	(2) COMPONENT/ ASSEMBLY	(3) MAINTENANCE FUNCTION	(4) MAINTENANCE LEVEL					(5) TOOLS AND EQUIPMENT	(6) REMARKS
			UNIT		INTERMED.		DEPOT		
			C	O	F	H	D		
1814	LASHING GEAR EQUIPMENT	INSPECT	0.2						A
		REPLACE			3.0			1-3	
		REPAIR	0.5		1.5			1-4	

**SECTION III. TOOL AND TEST EQUIPMENT REQUIREMENTS  
FOR  
LASHING GEAR EQUIPMENT**

Tool Or Test Eqpt Ref Code	Maint. Level	Nomenclature	National/NATO Stock Number	Tool Number
1	F	Toot kit, welders	5180-00-754-0661	(50980) SC-5180-90 -CL-N39
2	F	Torch, cutting and welding	3433-00-357-8116	(50980) SC-3433-90 -CL-N03
3	F	Welding machine, arc		(96073) 1341-0354
4	C	Tool kit, general mechanics	5180-00-699-5273	(50980) SC5180-90- CL-N05



**SECTION IV REMARKS  
LASHING GEAR EQUIPMENT**

REFERENCE CODE	REMARKS
A	REFERENCE TOOLS REQUIRED TO REMOVE/REPLACE LASHING AND DECK SOCKETS.

SECTION II MAINTENANCE ALLOCATION CHART FOR WORK BOAT, LIFEBOATS/DAVITS

(1) GROUP NUMBER	(2) COMPONENT/ ASSEMBLY	(3) MAINTENANCE FUNCTION	(4) MAINTENANCE LEVEL					(5) TOOLS AND EQUIPMENT	(6) REMARKS
			UNIT		INTERMED.	DEPOT			
			C	O	F	H	D		
1815	WORKBOAT,LIFEBOATS/ DAVITS	INSPECT	0.2						
		SERVICE	0.2						
		REPLACE		10.0				1	A
		REPAIR	1.0	10.0	10.0			1	
181501	BOAT,INFLATABLE,MAT	REPLACE		1.0				1	B
		REPAIR	1.0	2.0				1	
181502	MOTOR,OUTBOARD (MARINER)	INSPECT	0.2						C,E
		SERVICE	0.2						
		REPLACE		0.5				1-3	
		REPAIR	0.5	0.5				1	
181503	LIFE RAFT,INFLATABLE (MODULAR)	INSPECT	0.5						D
		REPLACE		1.0				1	
181504	CRANE ASSEMBLY	INSPECT	1.0						A,E,F
		REPLACE			10.0			1	
		REPAIR		3.0	5.0			1,3,4	
18150401	WINCH ASSEMBLY	REPLACE			5.0			1	
		REPAIR		0.5	3.0			1,3,4	
181505	DAVIT,PORTABLE	REPLACE		2.5				1	
		REPAIR		5.0				1	

**SECTION III. TOOL AND TEST EQUIPMENT REQUIREMENTS  
FOR  
WORKBOAT, LIFEBOATS/DAVITS**

Tool Or Test Eqpt Ref Code	Maint. Level	Nomenclature	National/NATO Stock Number	Tool Number
1	O,F	Tool kit, general mechanics	5180-00-699-5273	(50980) SC-5180-CL -N05
2	O	Lifting sling		(15434) 3375958
3	O,F	Torque wrench kit		(15434) 3377216
4	O,F	Tool kit, electricians	5180-00-391-1087	(80064) 9000S6202- 73125ALT2

**SECTION IV REMARKS  
WORKBOAT, LIFEBOATS/DAVITS**

REFERENCE CODE	REMARKS
A	COMPONENTS SUCH AS MOTOR/BRAKE AND GEAR REDUCER REPAIRS SHOULD BE PERFORMED BY THE VENDORS PERSONNEL/FACILITIES AND BE CONSIDERED AS A DIRECT EXCHANGE ITEM.
B	FIELD REPAIRS WILL BE LIMITED TO MINOR LEAKS. MAJOR REPAIRS WILL BE PERFORMED AT MANUFACTURERS REPAIR FACILITY.
C	REPAIRS OTHER THAN PLUGS,PROPELLER,GAS TANK,FUEL FILTER ELEMENT WILL BE BY LOCAL SUPPORT AT VENDORS FACILITY.
D	REPAIRS/PARTS REPLACEMENT WILL BE PERFORMED AT BF GOODRICH/COAST GUARD APPROVED FACILITY.
E	TEST FOR OPERATION PRIOR TO MISSION.

**SECTION II MAINTENANCE ALLOCATION CHART FOR CONTROL CENTERS/SWITCHBOARDS**

(1) GROUP NUMBER	(2) COMPONENT/ ASSEMBLY	(3) MAINTENANCE FUNCTION	(4) MAINTENANCE LEVEL					(5) TOOLS AND EQUIPMENT	(6) REMARKS
			UNIT		INTERMED.		DEPOT		
			C	O	F	H	D		
1816	CONTROL CENTERS/ SWITCHBOARD	INSPECT	0.5						
		TEST	0.5						
		REPLACE		5.0	5.0			1,2	A
		REPAIR	3.0	5.0	5.0			1,2	A
181601	CONTROL CENTER, MOTOR(AUXILIARY MACHINERY VENT ROOM NO.1)	INSPECT	0.2						
		TEST	0.1						
		REPLACE		2.0				1	A
		REPAIR	0.5	1.0				1	A
18160101	CONTROLLER,MOTOR (EMERGENCY LUBE OIL PRELUBE PUMP)	INSPECT	0.2						
		TEST	0.1						
		REPLACE		0.5				1	A
		REPAIR	0.5	1.0				1	A
18160102	CONTROLLER (NO 1 & 2 SSDG JACKET WATER HEATER)	INSPECT	0.2						
		TEST	0.1						
		REPLACE		0.5				1	A
		REPAIR	0.5	1.0				1	A
18160103	CONTROLLER,MOTOR (AIR COMPRESSOR NO. 1 & 2)	INSPECT	0.2						
		TEST	0.1						
		REPLACE		0.5				1	A
		REPAIR	0.5	1.0				1	A
18160104	CONTROLLER,MOTOR (DIRTY LUBE OIL PUMP)	INSPECT	0.2						
		TEST	0.1						
		REPLACE		0.5				1	A
		REPAIR	0.5	1.0				1	A
18160105	CONTROLLER (MAIN ENGINE 1 & 2) JACKET WATER HEATER)	INSPECT	0.2						
		TEST	0.1						
		REPLACE		0.5				1	A
		REPAIR	0.5	1.0				1	A
181602	CONTROL CENTER,MOTOR (AUXILIARY MACHINERY VENT ROOM NO.2)	INSPECT	0.5						
		TEST	0.1						
		REPLACE		4.0				1	A
		REPAIR	1.0	3.0				1	A
18160201	CONTROLLER,MOTOR (AUXILIARY SEA WATER COOLING PUMP)	INSPECT	0.2						
		TEST	0.1						
		REPLACE		0.5				1	A
		REPAIR	0.5	1.0				1	A

**SECTION II MAINTENANCE ALLOCATION CHART FOR CONTROL CENTERS/SWITCHBOARDS**

(1) GROUP NUMBER	(2) COMPONENT/ ASSEMBLY	(3) MAINTENANCE FUNCTION	(4) MAINTENANCE LEVEL					(5) TOOLS AND EQUIPMENT	(6) REMARKS
			UNIT		INTERMED.		DEPOT		
			C	O	F	H	D		
18160202	CONTROLLER,MOTOR (FUEL OIL TRANSFER PUMP NO.1)	INSPECT	0.2						
		TEST	0.1						
		REPLACE		0.5				1	A
		REPAIR	0.5	1.0				1	A
18160203	CONTROLLER (LUBE OIL PURIFIER HEATER)	INSPECT	0.2						
		TEST	0.1						
		REPLACE		0.5				1	A
		REPAIR	0.5	1.0				1	A
18160204	CONTROLLER,MOTOR (LUBE OIL PURIFIER)	INSPECT	0.2						
		TEST	0.1						
		REPLACE		0.5				1	A
		REPAIR	0.5	1.0				1	A
18160205	CONTROLLER,MOTOR (REDUCING GEAR COOLING WATER PUMP NO. 1 & 2)	INSPECT	0.2						
		TEST	0.1						
		REPLACE		0.5				1	A
		REPAIR	0.5	1.0				1	A
18160206	CONTROLLER,MOTOR (CLEAN LUBE OIL PUMP)	INSPECT	0.2						
		TEST	0.1						
		REPLACE		0.5				1	A
		REPAIR	0.5	1.0				1	A
181603	MOTOR,CONTROL CENTER (ENGINE ROOM VENT)	INSPECT	0.2						
		TEST	0.1						
		REPLACE		2.0				1	A
		REPAIR	0.5	1.0				1	A
18160301	CONTROLLER,MOTOR (ENGINE ROOM EXHAUST FAN)	INSPECT	0.2						
		TEST	0.1						
		REPLACE		0.5				1	A
		REPAIR	0.5	1.0				1	A
18160302	CONTROLLER,MOTOR (ENGINE ROOM SUPPLY FAN)	INSPECT	0.2						
		TEST	0.1						
		REPLACE		0.5				1	A
		REPAIR	0.5	1.0				1	A
181604	CONTROL CENTER,MOTOR (FORWARD DECK MACHINERY)	INSPECT	0.2						
		TEST	0.1						
		REPLACE		2.0				1	A
		REPAIR	0.5	1.0				1	A

**SECTION II MAINTENANCE ALLOCATION CHART FOR CONTROL CENTERS/SWITCHBOARDS**

(1) GROUP NUMBER	(2) COMPONENT/ ASSEMBLY	(3) MAINTENANCE FUNCTION	(4) MAINTENANCE LEVEL					(5) TOOLS AND EQUIPMENT	(6) REMARKS
			UNIT		INTERMED.		DEPOT		
			C	O	F	H	D		
18160401	CONTROLLER,MOTOR (BOW WINDLASS NO. 1 & 2)	INSPECT	0.2						
		TEST	0.1						
		REPLACE		0.5				1	A
		REPAIR	0.5	1.0				1	A
18160402	CONTROLLER,MOTOR (BOW THRUSTER STEERING MOTOR)	INSPECT	0.2						
		TEST	0.1						
		REPLACE		0.5				1	A
		REPAIR	0.5	1.0				1	A
18160403	CONTROLLER (BOW THRUSTER JACKET WATER HEATER)	INSPECT	0.2						
		TEST	0.1						
		REPLACE		0.5				1	A
		REPAIR		1.0				1	A
181605	CONTROLLER,MOTOR (STERN WINDLASS)	INSPECT	0.2						
		TEST	0.1						
		REPLACE		0.5				1	A
		REPAIR	0.5	1.0				1	A
181606	CONTROLLER,MOTOR (FIRE PUMP)	INSPECT	0.2						
		TEST	0.1						
		REPLACE		0.5				1	A
		REPAIR	0.5	1.0				1	A
181607	CONTROLLER,MOTOR (STEERING GEAR HYDRAULIC PUMP)	INSPECT	0.2						
		TEST	0.1						
		REPLACE		0.5				1	A
		REPAIR	0.5	1.0				1	A
181608	CONTROLLER,MOTOR (FRESH WATER PUMP NO.1 & 2)	INSPECT	0.2						
		TEST	0.1						
		REPLACE		0.5				1	A
		REPAIR	0.5	1.0				1	A
181609	CONTROLLER,MOTOR (BILGE AND BALLAST PUMP)	INSPECT	0.2						
		TEST	0.1						
		REPLACE		0.5				1	A
		REPAIR	0.5	1.0				1	A
181610	CONTROLLER,MOTOR (FUEL OIL TRANSFER PUMP NO.2)	INSPECT	0.2						
		TEST	0.1						
		REPLACE		0.5				1	A
		REPAIR	0.5	1.0				1	A

SECTION II MAINTENANCE ALLOCATION CHART FOR BASIC CRAFT

(1) GROUP NUMBER	(2) COMPONENT/ ASSEMBLY	(3) MAINTENANCE FUNCTION	(4) MAINTENANCE LEVEL					(5) TOOLS AND EQUIPMENT	(6) REMARKS
			UNIT		INTERMED.		DEPOT		
			C	O	F	H	D		
181611	CONTROLLER,MOTOR (GALLEY EXHAUST FAN)	INSPECT	6.2						
		TEST	0.1						
		REPLACE			0.5			1	A
		REPAIR	0.5		1.0			1	A
181612	CONTROLLER,MOTOR (LAVATORY EXHAUST FAN)	INSPECT	0.2						
		TEST	0.1						
		REPLACE			0.5			1	A
		REPAIR	0.5		1.0			1	A
181613	CONTROLLER,MOTOR (STEERING GEAR EXHAUST FAN)	INSPECT	0.2						
		TEST	0.1						
		REPLACE		0.5				1	A
		REPAIR	0.5	1.0				1	A
181614	CONTROLLER,MOTOR (TUNNEL SUPPLY FAN)	INSPECT	0.2						
		TEST	0.1						
		REPLACE		0.5				1	A
		REPAIR	0.5	1.0				1	A
181615	CONTROLLER,MOTOR (BOW THRUSTER SUPPLY FAN)	INSPECT	0.2						
		TEST	0.1						
		REPLACE		0.5				1	A
		REPAIR	0.5	1.0				1	A
181616	CONTROLLER,MOTOR (EMERGENCY GENERATOR ROOM SUPPLY FAN)	INSPECT	0.2						
		TEST	0.1						
		REPLACE		0.5				1	A
		REPAIR	0.5	1.0				1	A
181617	CONTROLLER,MOTOR (GALLEY MAKEUP SUPPLY FAN)	INSPECT	0.2						
		TEST	0.1						
		REPLACE		0.5				1	A
		REPAIR	0.5	1.0				1	A
181618	CONTROLLER,MOTOR (GALLEY VENT HOOD FAN)	INSPECT	0.2						
		TEST	0.1						
		REPLACE		0.5				1	A
		REPAIR	0.5	1.0				1	A
181619	CONTROLLER,MOTOR (GALLEY DUCT HEATER)	INSPECT	0.2						
		TEST	0.1						
		REPLACE		0.5				1	A
		REPAIR	0.5	1.0				1	A



**SECTION II MAINTENANCE ALLOCATION CHART FOR CONTROL CENTERS/SWITCHBOARDS**

(1) GROUP NUMBER	(2) COMPONENT/ ASSEMBLY	(3) MAINTENANCE FUNCTION	(4) MAINTENANCE LEVEL					(5) TOOLS AND EQUIPMENT	(6) REMARKS
			UNIT		INTERMED.		DEPOT		
			C	O	F	H	D		
181620	SWITCHBOARD,POWER (SHIP SERVICE)	INSPECT	0.5						
		TEST	0.2						
		SERVICE	0.5						
		REPLACE			5.0			1,2	
		REPAIR	0.5	2.0	5.0			1,2	
181621	SWITCHBOARD,EMERGENCY	INSPECT	0.5						
		TEST	0.2						
		SERVICE	0.5						
		REPLACE			4.0			1,2	
		REPAIR	0.5	2.0	2.0			1,2	

**SECTION III. TOOL AND TEST EQUIPMENT REQUIREMENTS  
FOR  
CONTROL CENTERS/SWITCHBOARDS**

Tool Or Test Eqpt Ref Code	Maint. Level	Nomenclature	National/NATO Stock Number	Tool Number
1	O,F	Tool kit, electricians	5180-391-1087	(80064) 9000S6202 73125ALT2
2	F	Lifting fixture		(15434) SF-125

**SECTION IV REMARKS  
CONTROL CENTERS/SWITCHBOARDS**

REFERENCE CODE	REMARKS
A	SELECTION OF OVERLOAD RELAY COILS, WHENEVER POSSIBLE, SHOULD BE MADE FROM ACTUAL MOTOR CURRENT AS SHOWN ON THE MOTOR NAMEPIATE OR AS OBTAINED FROM THE MOTOR MANUFACTURER.

SECTION II MAINTENANCE ALLOCATION CHART FOR BASIC CRAFT

(1) GROUP NUMBER	(2) COMPONENT/ ASSEMBLY	(3) MAINTENANCE FUNCTION	(4) MAINTENANCE LEVEL					(5) TOOLS AND EQUIPMENT	(6) REMARKS
			UNIT		INTERMED.		DEPOT		
			C	O	F	H	D		
1817	PROPELLER SHAFT ASSEMBLY	INSPECT	0.5					1,3	C B A,B
		TEST	0.2					1,3	
		REPLACE					*	1,2	
		REPAIR		0.5	5.0	20.0	*	1,3	
181701	PROPELLER, MARINE (LH)	REPLACE					*	B	
		REPAIR					*	A,B	
181701	PROPELLER, MARINE (RH)	REPLACE					*	B	
		REPAIR					*	A,B	
181702	BRAKE, EXPANDER TUBE	REPLACE			1.0			1,3,5	
		REPAIR			1.5			1	
18170201	ELEMENT, BRAKE	REPLACE			1.0			1	
		REPAIR			1.5			1	
181703	TACHOMETER, ELECTRICAL SELF-GENERATING SHAFT (TACHOMETER DIRECTIONAL)	ADJUST		0.5				1	
		REPLACE			1.0			1	
		REPAIR		0.5	0.5			1,4	

**SECTION III. TOOL AND TEST EQUIPMENT REQUIREMENTS  
FOR  
PROPELLER SHAFT ASSEMBLY**

Tool Or Test Eqpt Ref Code	Maint. Level	Nomenclature	National/NATO Stock Number	Tool Number
1	C,O,F,H	Tool kit, general mechanics	5180-00-699-5273	
2	H	Tool, special purpose wrench, make per drawing 8243008 detail 53A		(77408) DET 53A 8243008
3	C,O,F	Torque wrench kit		(15434) 33716
4	O,F	Fuse puller	5120-00-224-9453	
5	F	Lifting sling		(15434) 3375958

**SECTION IV. REMARKS**  
**PROPELLER SHAFT ASSEMBLY**

REFERENCE CODE	REMARKS
A	DEPOT LEVEL REPAIR/MAINTENANCE WILL BE PERFORMED ON A CASE BY CASE BASIS SUBJECT TO APPROVAL AND FUNDING BY THE NATIONAL MAINTENANCE POINT (NMP).
B	MAINTENANCE OF COMPONENTS EXTERIOR TO THE HULL SHOULD BE PERFORMED IN SHIPYARD DRYDOCK FACILITY.
C	OPERATIONAL TEST PRIOR TO MISSION.

SECTION II MAINTENANCE ALLOCATION CHART FOR BASIC CRAFT

(1) GROUP NUMBER	(2) COMPONENT/ ASSEMBLY	(3) MAINTENANCE FUNCTION	(4) MAINTENANCE LEVEL					(5) TOOLS AND EQUIPMENT	(6) REMARKS
			UNIT		INTERMED.		DEPOT		
			C	O	F	H	D		
1818	VALVES/STRAINERS	INSPECT	1.0						A,B
		REPLACE		3.5				1	
		REPAIR	3.0		6.0			1	
181801	VALVE,ANGLE	INSPECT	0.1						1,2
		REPLACE		0.5				1	
		REPAIR	1.0		1.0				
181802	VALVE,BALL,THREE WAY	INSPECT	0.1						1,3
		REPLACE		0.5					
		REPAIR	1.0		1.5	1			
181803	VALVE,BALL,THREE WAY	INSPECT	0.1						1,3
		REPLACE		0.5				1	
		REPAIR	1.0		1.0				
181804	VALVE,BALL THREE WAY	INSPECT	0.1						1,3
		REPLACE		0.5				1	
		REPAIR	1.0		1.0				
181805	VALVE,SWING CHECK	INSPECT	0.1						1,3
		REPLACE		0.5				1	
		REPAIR	1.0		1.5				
181806	STRAINER,SIMPLEX	INSPECT	0.1						1,3,4
		SERVICE	0.1						
		REPLACE		0.5				1	
181807	STRAINER,DUPLEX	REPAIR	1.0		0.5				1,3,4
		INSPECT	0.1						
		SERVICE	0.1		0.5			1	
181808	STRAINER,SIMPLEX	REPLACE		0.5					1,3
		REPAIR	1.0		1.0			1	
		INSPECT	0.1						
181809	STRAINER,BASKET	SERVICE	0.1						1,3
		REPLACE		0.5				1	
		REPAIR	1.0		0.5				

SECTION II MAINTENANCE ALLOCATION CHART FOR

VALVES/STRAINERS

(1) GROUP NUMBER	(2) COMPONENT/ ASSEMBLY	(3) MAINTENANCE FUNCTION	(4) MAINTENANCE LEVEL					(5) TOOLS AND EQUIPMENT	(6) REMARKS
			UNIT		INTERMED.	DEPOT			
			C	O	F	H	D		
181810	STRAINER,BASKET	INSPECT	0.1					1,3 1	
		SERVICE	0.1						
		REPLACE		0.5					
		REPAIR	1.0		0.5				
181811	STRAINER,BASKET	INSPECT	0.1					1,3 1	
		SERVICE	0.1						
		REPLACE		0.5					
		REPAIR	1.0		0.5				



**SECTION III. TOOL AND TEST EQUIPMENT REQUIREMENTS  
FOR  
VALVES/STRAINERS**

Tool Or Test Eqpt Ref Code	Maint. Level	Nomenclature	National/NATO Stock Number	Tool Number
1	C,O,F	Tool kit, general mechanics	5180-00-699-5273	(50980) SC-5180-90 CI-NO5
2	C,O	Portable welding equipment		(06073) 1341-0354
3	C,O	Torque wrench (30-300 ft-lb)	5120-01-125-5190	
4	C,O	Lifting sting		(15434) 3375958

**SECTION IV. REMARKS**

**VALVES/STRAINERS**

REFERENCE CODE	REMARKS
A	NOT REPLACED AS A GROUP. REPLACEMENT IS BY INDIVIDUAL COMPONENTS ONLY.
B	DEPOT LEVEL REPAIR/MAINTENANCE WILL BE PERFORMED ON A CASE BY CASE BASIS SUBJECT TO APPROVAL AND FUNDING BY THE NATIONAL MAINTENANCE POINT (NMP).

**SECTION II MAINTENANCE ALLOCATION CHART  
FOR PIPING SYSTEM**

(1) GROUP NUMBER	(2) COMPONENT/ ASSEMBLY	(3) MAINTENANCE FUNCTION	(4) MAINTENANCE LEVEL					(5) TOOLS AND EQUIPMENT	(6) REMARKS
			UNIT		INTERMED.	DEPOT			
			C	O	F	H	D		
1819	PIPING SYSTEM	INSPECT REPLACE REPAIR	1.0 50.0 5.5					1-6 1-6	A
181901	PIPING,POTABLE WATER	REPLACE REPAIR	1.5		3.0 2.0			1,3-6 1,3-6	
18190101	HEATER,HOT WATER	REPLACE REPAIR	0.5	2.0	1,2,6 2.5			1,2,6	
181902	PIPING,BILGE BALLAST AND FIREMAIN	INSPECT REPLACE REPAIR	1.0 1.5	A	3.0 2.0			1,3,4 1,3,4	
181903	PIPING,SEAWATER COOLING	INSPECT REPLACE REPAIR	1.0 1.5		3.0 2.0			1,3,4 1,3,4	A
181904	PIPING,FRESH WATER COOLING	REPLACE REPAIR	1.5		3.0 2.0			1,3,4 1,3,4	A
181905	PIPING,COMPRESSED AIR SYSTEM	REPLACE REPAIR	1.5		3.0 2.0			1,3,4 1,3,4	A
181906	PIPING,FIRE,WNQITOR AND WASHDOWN SYSTEM	REPLACE REPAIR	1.5		3.0 2.0			1,3,4 1,3,4	A
181907	PIPING,LUBE OIL TRANSFER/DIRTY OIL DISCHARGE	REPLACE REPAIR	1.5		3.0 2.0			1,3,4 1,3,4	A
181908	PIPING,HYDRAULIC OIL	REPLACE REPAIR	1.5		3.0 2.0			1,3,4 1,3,4	A
181909	PIPING,OILY WATER SEPARATOR	REPLACE REPAIR	1.5		3.0 2.0			1,3,4 1,3,4	A
181910	PIPING,BILGE MANIFOLD UNIT ASSEMBLY	REPLACE REPAIR	1.5		3.0 2.0			1,3,4 1,3,4	A
181911	PIPING,FUEL TRANSFER PUMP UNIT ASSEMBLY	REPLACE REPAIR	1.5		3.0 2.0			1,3,4 1,3,4	A

**SECTION II MAINTENANCE ALLOCATION CHART  
FOR PIPING SYSTEM**

(1) GROUP NUMBER	(2) COMPONENT/ ASSEMBLY	(3) MAINTENANCE FUNCTION	(4) MAINTENANCE LEVEL					(5) TOOLS AND EQUIPMENT	(6) REMARKS
			UNIT		INTERMED.	DEPOT			
			C	O	F	H	D		
181912	PIPING,SEWAGE AND PLUMBING	INSPECT	1.0					1,3,4 1,3,4	A
		SERVICE	0.5						
		REPLACE REPAIR	1.5	3.0	2.0				
181913	PIPING,BOWTHRUSTER SYSTEM	INSPECT	1.0					1,3,4 1,3,4	
		REPLACE REPAIR	1.5		3.0 2.0				
181914	PIPING,STEERING GEAR	INSPECT	0.5					1,3,4 1,3,4	A
		REPLACE REPAIR	1.5		3.0 2.0				
181915	PIPING,EMERGENCY GENERATOR	INSPECT	0.5					1,3,4 1,3,4	A
		REPLACE REPAIR	1.5		3.0 2.0				
181916	PIPING,FOAM PROPORTIONERS	INSPECT	0.5					1,3,4 1,3,4 1,3,4	A
		SERVICE	0.5						
		REPLACE REPAIR	1.5		3.0 2.0				
181917	PIPING,FIRE PUMP UNIT ASSEMBLY	REPLACE			3.0			1,3,4 1,3,4	A
		REPAIR	1.5		2.0		:		

**SECTION III. TOOL AND TEST EQUIPMENT REQUIREMENTS  
FOR  
PIPING SYSTEM**

Tool Or Test Eqpt Ref Code	Maint. Level	Nomenclature	National/NATO Stock Number	Tool Number
1	C,O,F	Tool kit, general mechanics	5180-00-699-5273	(50980) SC-5180-90 -CL-N05
2	O,F	Tool kit, electricians	5180-00-391-1087	(80064) 9000S202- 73125ALT2
3	F	Tool kit, welder	5180-00-754-0661	
4	F	Welding torch	3433-00-352-8116	
5	F	Tool kit soldering	3439-00-342-0531	
6	F	Torque wrench kit		(15434) 3377216

**SECTION IV REMARKS**

**PIPING SYSTEM**

REFERENCE CODE	REMARKS
A	NOT REPLACED AS A GROUP. REPLACE BY INDIVIDUAL COMPONENTS ONLY.

**SECTION II MAINTENANCE ALLOCATION CHART  
FOR HULL/MISCELLANEOUS**

(1) GROUP NUMBER	(2) COMPONENT/ ASSEMBLY	(3) MAINTENANCE FUNCTION	(4) MAINTENANCE LEVEL					(5) TOOLS AND EQUIPMENT	(6) REMARKS
			UNIT		INTERMED.	DEPOT			
			C	O	F	H	D		
1820	HULL/MISCELLANEOUS	INSPECT	1.0						
		REPLACE		6.0	4.0	12.0		1-3	
		REPAIR	1.0	8.0	6.0	18.0		1-3	A
182001	LADDER AND HANDRAILS	INSPECT	0.5						
		REPLACE		4.0				1-3	
		REPAIR	1.0	3.0				1-3	
18200101	PILOT HOUSE TOP LADDERS AND HANDRAILS	REPLACE		2.0				1-3	
		REPAIR		2.0				1-3	
18200102	LADDERS AND HAND RAILS (02 LEVEL)	REPLACE		2.0				1-3	
		REPAIR	0.5	2.0				1-3	
18200103	FORECASTLE DECK LADDER AND HANDRAILS	REPLACE		2.0				1-3	
		REPAIR	0.5	2.0				1-3	
18200104	MAIN DECK LADDERS AND HANDRAILS	REPLACE		2.0				1-3	
		REPAIR		2.0					
182002	TANK ARRANGEMENT	INSPECT	0.5						
		REPLACE				8.0		1-3	
		REPAIR				10.0		1-3	
182003	MISCELLANEOUS INDEPENDENT TANKS	INSPECT	0.5						
		REPLACE			4.0			1-3	
		REPAIR			3.0			1-3	
18200301	TANK, DAY, EMERGENCY DIESEL GENERATOR	REPLACE			4.0			1-3	
		REPAIR		1.0	3.0			1-3	
18200302	TANK, DAY, BOW THRUSTER ENGINE	REPLACE			4.0			1-3	
		REPAIR		1.0	3.0			1-3	
18200303	TANK, STORAGE, HYDRAULIC OIL	REPLACE			4.0			1-3	
		REPAIR		1.0	3.0			1-3	
1821	FM-200 SYSTEM								A
1822	WATER WASHDOWN SYSTEM (WWS)								A

**SECTION III. TOOL AND TEST EQUIPMENT REQUIREMENTS**  
**FOR**  
**HULL/MISCELLANEOUS**

Tool or Test Eqpt Ref Code	Maint. Level	Nomenclature	National/NATO Stock Number	Tool Number
1	C,F,H	Tool kit, general mechanics	5180-00-699-5273	(50980)
2	C,F,H	Tool kit, welder	5180-00-754-0661	SC-5180-CL-N05
3	C,F,H	Torch outfit	3433-00-357-8116	



**SECTION IV. REMARKS**

**HULL/MISCELLANEOUS**

REFERENCE CODE	REMARKS
A.	<p>DEPOT LEVEL REPAIR/MAINTENANCE WILL BE PERFORMED ON A CASE BY CASE BASIS SUBJECT TO APPROVAL AND FUNDING BY THE NATIONAL MAINTENANCE POINT (NMP).</p>

**SECTION IV. REMARKS**  
**FM-200 FIRE SUPPRESSION SYSTEM**  
**AND**  
**WATER WASHDOWN SYSTEM (WWS)**

REFERENCE CODE	REMARKS
A.	REFERENCE TM 55-1905-243-24&P FOR MAINTENANCE AND REPAIR OF FM-200 AND WATER WASHDOWN SYSTEM/COMPONENTS.

**Appendix C. EXPENDABLE/DURABLE SUPPLIES LIST**

---

**SECTION I. INTRODUCTION****C-1. SCOPE.**

This appendix lists expendable/durable supplies that you will need to operate and maintain the LCU 2000 Class Watercraft. This listing is for information only and is not authority to requisition the listed items. These items are authorized to you by CTA 50-790, Expendable/Durable Items (Except Medical, Class V Repair Parts, and Heraldic Items), or CTA 8-1 00, Army Medical Department Expendable/Durable Items. E

**C-2. EXPLANATION OF COLUMNS.**

a. Column 1. Item No. This number is assigned to the entry in the listing and is referenced \* in the narrative instructions to identify the item (e.g. "Use petroleum jelly, item 40, Appendix C".)

b. Column 2. Level. This column identifies the lowest level of maintenance that requires the item.

- C - Operator/crew
- O - Unit maintenance
- F - Direct support maintenance
- H - General support maintenance

c. Column 3. National stock number. This is the national stock number assigned to the item which you can use to requisition it.

d. Column 4. Item name, description, Commercial and Government Entity Code (CAGEC), and part number. This provides the other information you need to identify the item.

e. Column 5. Unit of measure. This code shows the physical measurement or count of an item, such as gallon, dozen, gross, etc.

## SECTION II. EXPENDABLE/DURABLE SUPPLIES LIST

(1) ITEM NUMBER	(2) LEVEL	(3) NATIONAL STOCK NUMBER	(4) DESCRIPTION	(5) U/M
1		2995-00-868-2735	Warning tags	EA
2		5350-01-211-4796	Crocus cloth	BX
3		4910-00-310-1971	Drain pan	EA
4		7920-00-044-9281	Soft cloth	BX
5		2835-00-170-9896	Teflon tape	RO
6		7050-00-961 -7663	Lubriplate No. 107	
7			Pneumatic grease No. 55	
8		9150-01-145-1259	High temperature grease	CN
9		5350-00-584-4653	Medium grit sandpaper	PG
10		7820-01-186-7330	Wooden blocks	SE
11		9150-01-141-6358	Silicone grease	EA
12		8030-00-680-0889	Loctite kit (catalog no. 0112)	EA
13		7420-00-160-4550	Utility pail	EA
14		7920-00-205-1711	Wiping rags	BE
15		8010-00-616-7694	Anti-seize compound	LB
16		7920-00-823-9773	Paper towels	
17			Silver polish	CN
18		8020-00-240-6361	Long, fine brush	EA
19		6520-01-153-6044	Porcelain cement/two-compartment adhesive	BT
20		9150-00-240-2251	Lubricating oil, 30W	CN
21			SAE 50 oil	CN
22			Glass Cleaner	
23			5000/7000 volt test rubber gloves	PR
24			Aluminum oxide abrasive cloth	

(1) ITEM NUMBER	(2) LEVEL	(3) NATIONAL STOCK NUMBER	(4) DESCRIPTION	(5) U/M
25		8030-01-206-5823	Clear silicone sealer	EA
26			1 -inch paintbrush	EA
27			Rubber eraser	EA
28			Paint remover	CN
29			Wire Brush	EA
30			Formula 150 primer	CN
31			Formula 151 paint (or equivalent)	CN
32			Gasket sealing compound	CN
33			Lubricating stick packing	EA
34		9150-00-235-5555	Grease, general purpose	LB
35		7510-00-282-6924	Marking chalk	
36			Liquid leak detector	CN
37			Petroleum base solvent	CN
38	O		Refrigerant R-1 2	LB
39	O		Petroleum jelly	CN
41		6850-00-110-4498	Drycleaning solvent (P-D680)	
42	O		Delimer	

APPENDIX D

TORQUE VALUES

**D-1. Scope.** SAE capscrews are graded according to the strength of the capscrew. They are marked on the head so the correct strength and torque value are known. The tables in this appendix will list the capscrew markings with correct torque values as well as values for pipe plugs and metric bolts.

CAUTION

When replacing capscrews, always use a capscrew of the same measurement and strength as the capscrew being replaced. Using incorrect capscrews can result in equipment damage. Bolts threaded into aluminum require much less torque.

NOTE

Always use torque values listed in the tables when specific torque values are unknown. The torque values listed in the tables are based on the use of lubricated threads.

Table D-1. Capscrew Markings and Torque Values

Capacity Body Size		SAE Grade #5 Cast Iron or Steel			SAE Grade #6 or #7 Cast Iron or Steel			SAE Grade #8 Cast Iron or Steel		
Inches-Thread	ft-lb.	Torque		Torque		Torque		ft-lb.	kgm	N-m
		ft-lb.	kgm	ft-lb.	kgm	ft-lb.	kgm			
1/4	-20	8	1.1064	10.8465	10	1.3630	13.5582	12	1.6596	16.2698
	-28	10	1.3830	13.5582				14	1.9362	18.9815
5/16	-18	17	2.3511	23.0489	19	2.6277	25.7605	24	3.3192	32.5396
	-24	19	2.6277	25.7605				27	3.7341	36.6071
3/8	-16	31	4.2873	42.0304	34	4.7022	46.0978	44	6.0852	59.6560
	-24	35	4.8405	47.4536				49	6.7767	66.4351
7/16	-14	49	6.7767	66.4351	55	7.6065	74.5700	70	9.6810	94.9073
	-20	55	7.6065	74.5700				78	10.7874	105.7538
1/2	-13	75	10.3725	101.6863	85	11.7555	115.2445	105	14.5215	142.3609
	-20	85	11.7555	115.2445				120	16.5860	162.6960
9/16	-12	110	15.2130	149.1380	120	16.5960	162.6960	155	21.4365	210.1490
	-18	120	16.5960	162.6960				170	23.5110	230.4860
5/8	-11	150	20.7450	203.3700	267	23.0961	226.4186	210	29.0430	284.7180
	-18	170	23.5110	230.4860				240	33.1920	325.3920
3/4	-10	270	37.3410	366.0660	280	38.7240	379.6240	375	51.8625	508.4250
	-16	295	40.7985	399.9610				420	58.0860	568.4360
7/8	- 9	395	54.6285	535.5410	440	60.8520	596.5520	605	83.6715	820.2590
	-14	435	60.1605	589.7730				675	93.3525	915.1650
1.0	- 8	590	81.5970	799.9220	660	91.2780	894.8280	910	125.8530	1233.7780
	-14	660	91.2780	849.8280				990	136.9170	1342.2420

Table D-1. Capscrew Markings and Torque Values - CONT



Capscrew Head Markings	SAE GRADE #5	OR	SAE GRADE #6 or #7	SAE GRADE #8
				

Table D-2. Pipe Plug Torque Values

Thread	Size		In Aluminum Components		In Cast Iron or Steel Components	
	Actual	Thread O.D.	Torque		Torque	
in	mm	(in)	N,m	(ft-lb.)	N'm	(ft-lb.)
1/16	8.1	(0.32)	5	(45 in-lb.)	15	(10)
1/8	10.4	(0.41)	15	(10)	20	(15)
1/4	13.7	(0.54)	20	(15)	25	(20)
3/8	17.3	(0.68)	25	(20)	35	(25)
1/2	21.6	(0.85)	35	(25)	55	(40)
3/4	26.7	(1.05)	45	(35)	75	(55)
1	33.5	(1.32)	60	(45)	95	(70)
1-1/4	42.2	(1.66)	75	(55)	115	(85)
1-1/2	48.3	(1.90)	85	(65)	135	(100)

Table D-3. Metric Bolt Torque Values

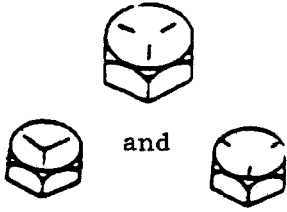
Thread for general purposes (size x pitch (mm))	Cast Iron or Steel			
	Head Mark 4		Head Mark 7	
	ft-lb.	(N-m)	ft-lb.	(N-m)
6 x 1.0	2.2 to 2.9	(3.0 to 3.9)	3.6 to 5.8	(4.9 to 7.8)
8 x 1.25	5.8 to 8.7	(7.9 to 12)	9.4 to 14	(13 to 19)
10 x 1.25	12 to 17	(16 to 23)	20 to 29	(27 to 39)
12 x 1.25	21 to 32	(29 to 43)	35 to 53	(47 to 72)
14 x 1.5	35 to 52	(48 to 70)	57 to 85	(77 to 110)
16 x 1.5	51 to 77	(67 to 100)	90 to 120	(130 to 160)
18 x 1.5	74 to 110	(100 to 150)	130 to 176	(180 to 230)
20 x 1.5	110 to 140	(150 to 190)	190 to 240	(160 to 320)
22 x 1.5	150 to 190	(200 to 260)	250 to 320	(340 to 430)
24 x 1.5	190 to 240	(260 to 320)	310 to 410	(420 to 550)

**GLOSSARY**

## SECTION I. ABBREVIATIONS

cm	Centimeter
hrs	Hours
H.P.	High pressure
Hz	Hertz
id	Inside diameter
kg	Kilogram
lb.	Pound
MCHRY	Machinery
No	Number
Para	Paragraph
P/N	Part Number
ppm	Parts per million
psi	Pounds per square inch
qty	Quantity
RPM	Revolutions per minute
V	Volts
Vac	Volts alternating current
Vdc	Volts direct current



**GLOSSARY - CONT**

SECTION II. DEFINITIONS

Blind End	AC motor shaft end that is on the side of the fan assembly.
Corrosion	A substance, such as rust, resulting from the act or process of dissolving or wearing away metals.
Corrosive	Substances capable of producing corrosion.
Damage	A physical deficiency to a part or component, such, as cracks, bends, breaks, tears, or broken parts.
Flammable	Easily ignitable and burning with great rapidity.
Journals	The part of a shaft or axle supported by a bearing.
Reciprocating	A device having a crankshaft turned by linearly reciprocating pistons.
Sheave	A wheel or disk with a grooved rim, especially one used as a pulley.
Toxic	Poisonous.

ALPHABETICAL INDEX

Subject; Paragraph

Subject; Paragraph

A

A - CONT

Accommodation Air Condition  
 Power Distribution  
 Removal; 3-153  
 Repair; 3-153  
 Replacement; 3-153  
 Air Preparation System  
 Assembly; 2-121  
 Disassembly; 2-121  
 Removal; 2-121  
 Repair; 2-121  
 Replacement; 2-121  
 Air Starting System; 1-14c  
 Airports, Fixed Lights, and Windows;  
 1-34  
 Alternating Current Motor  
 Dirty Lube Oil Rotary Pump Unit  
 Removal; 2-109  
 Replacement; 2-109  
 Fuel Oil Transfer Rotary Pump  
 Unit  
 Removal; 2-103  
 Replacement; 2-103  
 Fresh Water Centrifugal Unit  
 Removal; 2-96  
 Replacement; 2-96  
 Fresh Water Booster Centrifugal  
 Pump Unit)  
 Removal; 2-98  
 Replacement; 2-98  
 Prelube Oil Transfer Rotary Pump  
 Unit  
 Removal ; 2-106  
 Replacement; 2-106  
 Reduction Gear Cooling Water  
 Centrifugal Pump Unit  
 Removal ; 2-111  
 Replacement; 2-111  
 Analog Remote Module Assembly  
 Assembly; 2-137, 3-129  
 Disassembly; 2-137, 3-129  
 Removal;3-1  
 Replacement; 2-39  
 Repair; 2-137, 3-129  
 Replacement; 3-129  
 Annunciator (Engineer's Quarters  
 and Galley  
 Replacement;  
 Assembly; 2-131  
 Disassembly; 2-131  
 Inspection; 3-125  
 Removal; 3-125  
 Repair; 2-131, 3-125  
 Replacement; 3-125

Arc Welding Machine  
 Assembly; 3-54  
 Disassembly; 3-54  
 Removal; 2-51  
 Repair; 2-51, 3-54  
 Replacement; 2-51  
 Autopilot; 1-18  
 Autopilot Control Assembly  
 Removal; 3-117  
 Repair; 3-117  
 Replacement; 3-117  
 Auxiliary Machinery Motor Control  
 Center Power Distribution  
 Removal; 2-163, 3-147  
 Replace; 3-147  
 Replacement; 2-163, 3-147

B

Base Unit Assembly  
 Assembly; 3-72  
 Disassembly; 3-72  
 Removal; 2-64  
 Repair; 3-72  
 Replacement; 2-64  
 Battery Storage Group  
 Removal; 2-193  
 Repair; 2-193, 3-178  
 Replacement; 2-193  
 Bilge/Ballast and Firemain Piping  
 System; 1-23  
 Bilge/Ballast Piping System; 1-23a  
 Bilge/Ballast Pump Power  
 Distribution  
 Repair; 3-160  
 Replacement;2-173  
 Blinker Light  
 Assembly; 2-39  
 Disassembly; 2-39  
 Removal; 2-39  
 Repair; 2-39  
 Replace; 2-29  
 Boat Davit Power  
 Distribution  
 Repair;3-159  
 and Galley)  
 2-172  
 Boatswain Storeroom; 1-25a  
 Booster Heaters, 1-22f  
 Booster Pump; 1-22e

INDEX - CONT

Subject, Paragraph

**B - CONT**

Bow Ramp Control; 1-12i  
 Bow Ramp Control Panel  
     Forecastle Assembly; 2-150  
     Disassembly; 2-150  
     Removal; 2-150  
     Repair; 2-150  
     Replacement; 2-150  
     Pilothouse Console  
         Assembly; 2-149  
         Disassembly; 2-149  
         Removal; 2-149  
         Repair; 2-149  
         Replacement; 2-149  
 Bow Ramp Control System  
     Removal; 2-147  
     Repair; 2-147  
     Replacement; 2-147  
 Bowl Assembly  
     Assembly; 4-13  
     Disassembly; 4-13  
     Removal; 3-16  
     Repair; 4-13  
     Replacement; 3-16  
 Bowthruster Battery Assembly  
     Repair; 3-184  
 Bowthruster Control System  
     Removal; 2-154  
     Repair; 2-154  
     Replacement; 2-154  
 Bowthruster Day Tank  
     Assembly; 3-267  
     Disassembly; 3-267  
     Removal; 3-267  
     Repair; 3-267  
     Replacement; 3-267  
 Bowthruster/Fire Pump Valve  
     System  
         Assembly; 2-126  
         Disassembly; 2-126  
         Removal; 2-126  
         Repair; 2-126  
         Replacement; 2-126  
 Bowthruster Battery Assembly  
     Removal; 2-202  
     Replacement; 2-202  
 Bowthruster Battery Charger  
     Removal; 2-203  
     Repair; 2-203  
     Replacement; 2-203

Subject, Paragraph

**B - CONT**

Bowthruster Control; 1.12g  
 Bowthruster Engine Day Tank  
     Removal; 2-380  
     Replacement; 2-380  
 Brazed Fittings  
     Removal; 3-235  
     Repair; 3-235  
     Replacement; 3-235  
 Bridge Multi-Remove Module  
     Removal; 3-135  
     Repair; 3-135  
     Replacement; 3-135  
 Bridge Panel Assembly  
     Assembly; 2-135, 2-143  
     Disassembly; 2-135, 2-143  
     Removal; 3-127, 3-134  
     Repair; 2-135, 2-143, 3-127  
         3-134  
     Replacement; 3-127, 3-134

**C**

Calibrate Control Module Assembly and  
     Sensing Module Assembly  
         Calibration; 4-19  
 Carriage Unit Assembly  
     Assembly; 3-69  
     Disassembly; 3-69  
     Removal; 2-61  
     Repair; 3-61  
     Replacement; 2-61  
 Central Processing Unit  
     Assembly; 2-136, 2-144, 3-136  
     Disassembly; 2-136, 2-144, 3-136  
     Removal; 3-128, 3-136  
     Repair; 2-136, 2-144, 3-128,  
         3-136  
     Replacement; 3-128, 3-136  
 Centrifugal Pump Unit  
     Auxiliary Seawater Cooling  
         Assembly; 3-111  
         Disassembly; 3-111  
         Removal; 2-99  
         Repair; 2-99, 3-111  
         Replacement; 2-99  
 Fresh Water  
     Assembly; 3-109  
     Disassembly; 3-109  
     Removal; 2-95

## INDEX - CONT

Subject, Paragraph

## C - CONT

Repair; 2-95, 3-109  
   Replacement; 2-95  
 Fresh Water Booster  
   Assembly; 3-110  
   Disassembly; 3-110  
   Removal; 2-97  
   Repair; 2-97, 3-110  
   Replacement; 2-97  
 Reduction Gear Cooling Water  
   Assembly; 3-114  
   Disassembly; 3-114  
   Removal; 2-110  
   Repair; 2-110, 3-114  
   Replacement; 2-110  
 Characteristics, Capabilities, and  
   Features; 1-6  
 Checking Unpacked Equipment; 2-4, 3-4,  
   4-4  
 Circulation Heater  
   Assembly; 4-17  
   Disassembly; 4-17  
   Removal; 3-19  
   Repair; 4-17  
   Replacement; 3-19  
 Column and Base Assembly  
   Assembly; 3-68  
   Disassembly; 3-68  
   Removal; 2-59  
   Repair; 3-68  
   Replacement; 2-59  
 Commissary Equipment; 1-15  
 Commissary/Laundry Equipment; 2-6i  
 Common Tools and Equipment; 2-1, 3-1,  
   4-1  
 Compactor, Solid Waste  
   Assembly; 3-83  
   Disassembly; 3-83  
   Adjustment; 2-75  
   Removal; 2-75  
   Repair; 3-83  
   Replacement; 2-75  
 Compressed Air Piping System; 1-27  
 Control and Monitoring System; 1-12  
 Control Centers/Switchboard; 2-6p  
 Control Module Assembly  
   Removal; 2-28  
   Repair; 2-28  
   Replacement; 2-28  
 Control Panel (Winch Room)  
   Assembly; 2-148

Subject, Paragraph

## C - CONT

Disassembly; 2-148  
 Removal; 2-148  
 Repair; 2-148  
 Replacement; 2-148  
 Control Printed Circuit Board  
   Removal; 3-59  
   Repair; 3-59  
   Replacement; 3-59  
 Control, Subsystem; 2-6k  
 Control Unit Assembly  
   Bow Thruster  
     Assembly; 2-156  
     Disassembly; 2-156  
     Removal; 2-156  
     Repair; 2-156  
     Replacement; 2-156  
 Controller 1, SSDG Jacket Water  
   Heater No. 1 and No. 2  
     Removal; 2-224  
     Replacement; 2-224  
     Test; 2-224  
 Controller 2, SSDG Jacket Water  
   Heater No. 1 and No. 2  
     Assembly; 2-225  
     Disassembly; 2-225  
     Repair; 2-225  
 Controller  
   Bowthruster Jacket Water Heater  
     Assembly; 2-259  
     Disassembly; 2-259  
     Removal; 2-258  
     Repair; 2-259  
     Replacement; 2-258  
 Engine Room Exhaust Fan  
   Assembly; 2-249  
   Disassembly; 2-249  
   Repair; 2-249  
 Copper Solder Adapters/Connectors  
   Removal; 3-218  
   Repair; 3-218  
   Replacement; 3-218  
 Cooling System; 1-14e  
 Countermeasure Washdown; 1-17e  
 Crane Assembly  
   Assembly; 2-218, 3-198  
   Disassembly; 2-218, 3-198  
   Removal; 3-198  
   Repair; 2-218, 3-198  
   Replacement; 3-198

INDEX - CONT

Subject, Paragraph

Subject, Paragraph

D

D - CONT

Dead Man Alarm; 1-12j  
 Deprocessing Equipment; 2-5  
 Destruction of Army Materiel; 1-3  
 Detailed Procedures; 2-13, 3-10, 4-11  
 Diesel Fuel Oil Filter/Separator  
     Assembly; 2-25, 4-18  
     Disassembly; 2-25, 4-18  
     Removal; 3-20  
     Repair; 2-25, 4-18  
     Replacement; 3-20  
 Differential Pressure Gauge  
     Removal; 2-321  
     Repair; 2-321  
     Replacement; 2-321  
 Directional Control Rotary Valve  
 (Control Station, Pilothouse)  
     Adjustment; 2-117  
     Assembly; 2-117  
     Disassembly; 2-117  
     Removal; 2-117  
     Repair; 2-117  
     Replacement; 2-117  
     Test; 2-117  
 Dishwasher  
     Assembly; 3-90  
     Disassembly; 3-90  
     Removal; 2-82  
     Repair; 3-90  
     Replacement; 2-82  
 Dishwasher Pump and Motor  
     Assembly; 3-91  
     Disassembly; 3-91  
     Repair; 3-91  
 Doors, Hatches, and Scuttles; 1-32  
 Double Gear Pump  
     Removal; 2-19  
     Replacement; 2-19  
 Double Gear Pump Assembly  
     Assembly; 3-15  
 Disassembly; 3-15  
     Repair; 3-15  
 Drum Assembly  
     Assembly; 3-48  
     Disassembly; 3-48  
     Assembly; 3-48

Removal; 3-48  
 Repair; 3-48  
 Replacement; 3-48  
 Dryer  
     Cabinet, Exhaust Duct, and Base  
     Group  
         Removal; 2-94  
         Repair; 3-108  
         Replacement; 2-94  
     Front Bulkhead and Cylinder Assembly  
         Removal; 2-90  
         Repair; 3-104  
         Replacement; 2-90  
     Heater Box Group  
         Removal; 2-92  
         Repair; 3-106  
         Replacement; 2-92  
     Motor and Exhaust Fan Group  
         Removal; 2-93  
         Repair; 3-107  
         Replacement; 2-93  
     Rear Bulkhead and Cylinder Roller  
     Group  
         Removal; 2-91  
         Repair; 3-105  
         Replacement; 2-91  
 Dual Station Throttle Control; 1-12c

E

Electric Food Mixing Machine  
     Assembly; 3-62  
     Disassembly; 3-62  
     Removal; 2-56  
     Repair; 2-56, 3-62  
     Replacement; 2-56  
 Electric Meat Slicing Machine  
     Removal; 2-60  
     Repair; 2-60  
     Replacement; 2-60  
 Electric Motor (Auxiliary Seawater  
 Centrifugal Pump Unit)  
     Removal; 2-100  
     Replacement; 2-100  
 Electric Motor Assembly  
     Assembly; 4-12

INDEX - CONT

Subject, Paragraph

Subject, Paragraph

E - CONT

E - CONT

Disassembly; 4-12  
 Removal; 2-17  
 Repair; 4-12  
 Replacement; 2-17  
 Electric Range Assembly  
   Assembly; 3-60  
   Disassembly; 3-60  
   Removal; 2-54  
   Repair; 2-54, 3-60  
   Replacement; 2-54  
 Electrical Horn  
   Assembly; 2-44  
   Disassembly; 2-44  
   Removal; 2-43  
   Repair; 2-44  
   Replacement; 2-43  
   Test; 2-42  
 Electrical Self Generating Shaft  
   Tachometer  
     Adjustment; 2-306  
     Assembly; 2-307  
     Disassembly; 2-307  
     Removal; 3-205  
     Repair; 2-307, 3-205  
     Replacement; 3-205  
 Electrical Subsystems; 2-6e  
 Electrical Unit Assembly  
   Assembly; 3-74  
   Disassembly; 3-74  
   Removal; 2-66  
   Repair; 3-74  
   Replacement; 2-66  
 Electronic Component  
   Assembly  
     Assembly; 3-55  
     Disassembly; 3-55  
     Removal; 3-55  
     Repair; 3-55  
     Replacement; 3-55  
 Electronic Module Assembly  
   Assembly; 3-57  
   Disassembly; 3-57  
   Removal; 2-53, 3-57  
   Repair; 2-53, 3-57  
   Replacement; 2-53, 3-57  
 Electrical System; 1-21  
 Emergency Diesel Generator  
   Day Tank  
     Assembly; 3-266

Disassembly; 3-266  
 Removal; 2-379, 3-266  
 Repair; 3-266  
 Replacement; 2-379, 3-266  
 Emergency Generator Battery Assembly  
   Removal; 2-198  
   Repair; 2-198, 3-182  
   Replacement; 2-198  
 Battery Charger  
   Removal; 2-199  
   Repair; 2-199  
   Replacement; 2-199  
 Switchboard  
   Assembly; 2-298  
   Disassembly; 2-298  
   Removal; 3-201  
   Repair; 2-298, 3-201  
   Replacement; 3-201  
   Test; 2-298  
 Switchboard Battery Assembly  
   Repair; 3-179  
 Switchboard Circuit Breakers  
   Assembly; 2-300, 2-301, 2-302,  
     2-303  
   Disassembly; 2-300, 2-301, 2-302,  
     2-303  
   Removal; 2-299  
   Repair; 2-299, 2-300, 2-301,  
     2-302, 2-303  
   Replacement; 2-299  
   Test; 2-299, 2-300, 2-301,  
     2-302, 2-303  
 Switchboard Fuse Panel  
   Assembly; 2-304  
   Disassembly; 2-304  
   Repair; 2-304  
 Emergency Power Distribution  
   120V  
     Removal; 2-185  
     Repair; 2-185, 3-172  
     Replacement; 2-185  
   240V  
     Removal; 2-184  
     Repair; 3-171  
     Replacement; 2-184  
   24VDC  
     Removal; 2-190  
     Repair; 2-190, 3-176

INDEX - CONT

Subject, Paragraph

**E - CONT**

Replacement; 2-190  
 Emergency Power Lighting  
     Repair; 2-189, 3-175  
     Replacement; 2-189  
 Emergency Switchboard; 1-Ild  
 Emergency Switchboard Assembly  
     Battery  
         Assembly; 2-194  
         Disassembly; 2-194  
         Repair; 2-194, 3-179  
 Emergency Switchboard Battery Charger  
     Assembly; 2-195  
     Disassembly; 2-195  
     Removal; 2-195  
     Repair; 2-195, 3-180  
     Replacement; 2-195  
 Engine Instrument and Control Panel;  
     1-14a  
 Engine Order Telegraph (EOT); 1-12e  
 Engine Order Telegraph System  
     Removal 3-133  
     Repair; 2-142, 3-133  
     Replacement; 3-133  
 Engine, Port, Remote Module  
     Removal; 2-130, 3-124  
     Repair; 2-130, 3-124  
     Replacement; 2-130, 3-124  
 Engine Room Air Condition Power  
     Distribution  
     Removal; 3-154  
     Repair; 3-154  
     Replacement; 3-154  
 Engine Room Console (ERC); 1-12a  
 Engine Room Control Station  
     Adjustment; 2-118  
     Assembly; 2-118  
     Disassembly; 2-118  
     Removal; 2-118  
     Repair; 2-118  
     Replacement; 2-118  
     Test; 2-118  
 Engine Room Multi-Remote Module  
     Assembly; 2-145  
     Disassembly; 2-145  
     Removal; 2-129, 3-123, 3-137  
     Repair; 2-129, 2-145, 3-123,  
         3-137  
     Replacement; 2-129, 3-123, 3-137

Subject, Paragraph

**E - CONT**

Engine Room Panel Assembly  
     Assembly; 2-128, 2-146  
     Disassembly; 2-128, 2-146  
     Removal; 3-122, 3-138  
     Repair; 2-128, 2-146, 3-122,  
         3-138  
     Replacement; 3-122, 3-138  
 Engine Room Vent Motor Control  
     Center Power Distribution  
     Removal; 2-166, 3-150  
     Repair; 3-150  
     Replacement; 2-166, 3-150  
 Engine, Starboard, Remote Module  
     Assembly; 2-133  
     Disassembly; 2-133  
     Removal; 3-126  
     Repair; 2-133, 3-126  
     Replacement; 3-126  
 Engineer's Assistance Needed; 1-12k  
 Entertainment System; 2-6c  
 Entertainment System  
     Removal; 2-15  
     Repair; 2-15  
     Replacement; 2-15  
 Equipment Data; 1-8  
 Expander Tube Brake  
     Assembly; 3-204  
     Disassembly; 3-204  
     Removal; 3-203  
     Repair; 3-204  
     Replacement; 3-203  
 Explanation of PMCS Table; 2-10, 3-7

**F**

Faucet  
     Galley  
         Removal; 2-324  
         Repair; 2-324  
         Replacement; 2-324  
     Laundry Tub Faucet  
         Removal; 2-325  
         Repair; 2-325  
         Replacement; 2-325  
 Lavatory  
     Removal; 2-323  
     Repair; 2-323  
     Replacement; 2-323

INDEX - CONT

Subject, Paragraph

Subject, Paragraph

**F - CONT**

**F - CONT**

Fire Detection Control Panel  
with Thermostats  
  Assembly; 2-152, 3-140  
  Disassembly; 2-152, 3-140  
  Removal; 3-140  
  Repair; 2-152, 3-140  
  Replacement; 3-140  
Fire Detection System; 1-13  
Fire Detection System  
  Assembly; 2-151  
  Disassembly; 2-151  
  Removal; 3-139  
  Repair; 2-151, 3-139  
  Replacement; 3-139  
Fire Detection; 1-12h  
Fire Fighting System; 1-17  
Fire Hose Assembly  
  Removal; 2-333  
  Repair; 2-333  
  Replacement; 2-333  
**Fire Main and Foam Piping System;  
1-23b**  
Fire Monitors; 1-17d  
Fire Pump Power Distribution  
  Number 1  
    Removal; 2-176  
    Repair; 3-163  
    Replacement; 2-176  
  Number Two  
    Removal; 2-165  
    Replacement; 2-176  
Fire Pump Number Two Motor  
  Control Center Power  
  Distribution  
    Removal; 3-149  
    Repair; 3-149  
    Replacement; 3-149  
Fire Pump Power Distribution Number  
  Two  
    Removal; 2-165  
    Replacement; 2-165  
Fire Stations; 1-17c  
Fixed Window  
  Double Pane  
    Assembly; 3-193  
    Disassembly; 3-193  
    Removal; 3-193  
    Repair; 3-193  
    Replace; 3-193  
    Replacement; 3-193  
Rotary Window  
  Assembly; 3-194

  Disassembly; 3-194  
  Removal; 3-194  
  Repair; 3-82  
  Replacement; 3-194  
Right/Left Hand  
  Assembly; 3-195  
  Disassembly; 3-195  
  Removal; 3-195  
  Repair; 3-195  
  Replacement; 3-195  
Single Pane  
  Assembly; 3-196  
  Disassembly; 3-196  
  Removal; 3-196  
  Repair; 3-196  
  Replacement; 3-196  
Float Switch  
  Assembly; 3-43  
  Disassembly; 3-43  
  Removal; 3-43  
  Repair; 3-43  
  Replacement; 3-43  
Floodlights  
  Removal; 2-182, 2-187  
  Repair; 2-182, 2-187  
  Replacement; 2-182, 2-187  
Foam Proportioners; 1-17b  
Forward Deck Machinery Motor  
  Control Center Power  
  Distribution  
    Removal; 2-164, 3-148  
    Repair; 3-148  
    Replacement; 2-164, 3-148  
Frame Assembly  
  Assembly; 4-16  
  Disassembly; 4-16  
  Removal; 4-16  
  Repair; 4-16  
  Replacement; 4-16  
Freezer, F-20 Mechanical, Food  
  Assembly; 3-79  
  Disassembly; 3-79  
  Removal; 2-71  
  Repair; 2-71, 3-79  
  Replacement; 2-71  
Refrigeration Condenser  
  Assembly; 3-80  
  Disassembly; 3-80  
  Removal; 2-72  
  Repair; 3-80



INDEX - CONT

Subject, Paragraph

Subject, Paragraph

F - CONT

G - CONT

Replacement; 2-72  
 Refrigeration Evaporator Coil  
   Assembly; 3-81  
   Disassembly; 3-81  
   Removal; 2-73  
   Repair; 3-81  
   Replacement; 2-73  
 Freezer, F-30 Mechanical, Food  
   Assembly; 3-87  
   Disassembly; 3-87  
   Removal; 2-79  
   Repair; 2-79, 3-87  
   Replacement; 2-79  
 Refrigeration Condenser  
   Assembly; 3-88  
   Disassembly; 3-88  
   Removal; 2-80  
   Repair; 3-88  
   Replacement; 2-80  
 Refrigeration Evaporator Coil  
   Assembly; 3-89  
   Disassembly; 3-89  
   Removal; 2-81  
   Repair; 3-89  
   Replacement; 2-81  
 Fresh Water Piping System; 1-22  
 Fresh Water Pump Power Distribution  
   Number 1  
     Repair; 3-156  
     Replacement; 2-169  
   Number 2  
     Repair; 3-157  
     Replacement; 2-170  
 Fuel System; 1-14b  
 Fuel Oil Transfer Piping System; 1-26  
 Furniture and Fixtures Group;  
   Removal; 2-14  
   Repair; 2-14  
   Replacement; 2-14  
 Furniture and Furnishings; 2-6b  
 FW Pumps No. 1 and 2; 1-22a

Replacement; 2-74  
 Gauge Panel Assembly  
   Removal; 2-27  
   Repair; 2-27  
   Replacement; 2-27  
 Gauge Plate and Indexing Mechanism  
   Assembly; 3-71  
   Disassembly; 3-71  
   Removal; 2-63  
   Repair; 2-63; 3-71  
   Replacement; 2-63  
 Gearmate Control Panel  
   (See paragraph 2-119)  
   Adjustment; 2-120  
   Assembly; 2-120  
   Disassembly; 2-119  
   Removal; 2-119  
   Repair; 2-119  
   Replacement; 2-119  
 Gearmate Control System  
   Adjustment; 2-119  
   Assembly; 2-119  
   Disassembly; 2-119  
   Removal; 2-119  
   Repair; 2-119  
   Replacement; 2-119  
 Generator Number One Battery Assembly  
   Removal; 2-200  
   Repair; 2-200, 3-183  
   Replacement; 2-200  
 Generator Number One Battery Charger  
   Removal; 2-201  
   Repair; 2-201  
   Replacement; 2-201  
 Generators Remote Module  
   Assembly; 2-138  
   Disassembly; 2-138  
   Removal; 3-130  
   Repair; 2-138, 3-130  
   Replacement; 3-130  
 Governor Actuator Assembly  
   Removal; 2-123  
   Repair; 2-123  
   Replacement; 2-123  
 Manual Over-Ride  
   Assembly; 2-124  
   Disassembly; 2-124  
   Repair; 2-124

G

Garbage Disposal  
   Assembly; 3-82  
   Disassembly; 3-82  
   Removal; 2-74  
   Repair; 3-82

INDEX - CONT

Subject, Paragraph

**H**

HALON/Firefighting Equipment; 2-6a  
 HALON 1301 Fire Suppression System;  
 1-17a  
 HALON Subsystem, Paint Locker and  
 Main Machinery Room  
 Removal; 3-13  
 Repair; 3-13  
 Replacement; 3-13  
 Carbon Dioxide Cylinders  
 Service; 3-11  
 Halon Tanks  
 Service; 3-12  
 High Frequency Assembly  
 Assembly; 3-56  
 Disassembly; 3-56  
 Removal; 3-56  
 Repair; 3-56  
 Replacement; 3-56  
 Hood Assembly  
 Assembly; 2-21  
 Disassembly; 2-21  
 Repair; 2-21  
 Hot Water Heater; 1-22d  
 Hot Water Heater  
 Assembly; 3-220  
 Disassembly; 3-220  
 Removal; 2-328, 3-220  
 Repair; 2-328, 3-220  
 Replacement; 2-328, 3-220  
 Horizontal Gear Assembly;  
 Assembly; 4-15  
 Disassembly; 4-15  
 Removal; 3-18  
 Repair; 4-15  
 Replacement; 3-18  
 Hull/Ladders/Rails/Foundations; 2-6c  
 Hydraulic Oil Storage Tank  
 Assembly; 3-268  
 Disassembly; 3-268  
 Removal; 2-381, 3-268  
 Repair; 3-268  
 Replacement; 2-381, 3-268  
 Hydraulic Oil Supply Piping System; 1-25  
 Hydropneumatic Tank  
 Removal; 3-219  
 Repair; 3-219  
 Replacement; 3-219

Subject, Paragraph

**I**

Indicator Panel  
 Assembly; 2-41  
 Disassembly; 2-41  
 Removal; 2-40, 2-41  
 Repair; 2-40, 2-41  
 Replacement; 2-40,2-41  
 Inflatable Mat Boat  
 Assembly; 2-215  
 Disassembly; 2-215  
 Removal; 2-215  
 Repair; 2-215  
 Replacement; 2-215  
 Initial Setup Procedure; 2-7, 3-5, 4-5  
 Interface Printed Circuit Board  
 Assembly; 3-58  
 Disassembly; 3-58  
 Removal; 3-58  
 Repair; 3-58  
 Replacement; 3-58  
 Interface Unit Assembly  
 Assembly; 2-139, 2-140  
 Disassembly; 2-139, 2-140  
 Removal; 2-132, 2-134, 3-131  
 Repair; 2-132, 2-134, 2-139,  
 2-140, 3-131  
 Replacement; 2-132, 2-134, 3-131  
 Intermediate Shaft Assembly  
 Assembly; 3-64  
 Disassembly; 3-64  
 Repair; 3-64  
 Isolation Control Unit  
 Removal; 3-120  
 Repair; 3-120  
 Replacement; 3-120

**J**

Junction Box Assembly  
 Assembly; 3-119  
 Disassembly; 3-119  
 Removal; 3-119  
 Repair; 2-115, 3-119  
 Replacement; 3-119

INDEX - CONT

Subject, Paragraph

**K**

Knife Sharpener Unit  
 Assembly; 3-75  
 Disassembly; 3-75  
 Removal; 2-67  
 Repair; 3-75  
 Replacement; 2-67  
 Knife Unit Assembly  
 Assembly; 3-70  
 Disassembly; 3-70  
 Removal; 2-62  
 Repair; 3-70  
 Replacement; 2-62

**L**

Ladders and Handrails  
 Removal; 2-374  
 Repair; 2-374  
 Replacement; 2-374  
 Forecastle Deck  
 Removal; 2-377  
 Repair; 2-377  
 Replacement; 2-377  
 Main Deck  
 Removal; 2-378  
 Repair; 2-378  
 Replacement; 2-378  
 Pilothouse Top  
 Removal; 2-375  
 Repair; 2-375  
 Replacement; 2-375  
 02 Level  
 Removal; 2-376  
 Repair; 2-376  
 Replacement; 2-376  
 Lashing Gear  
 Assembly; 2-214  
 Disassembly; 2-214  
 Repair; 2-214  
 Lashing Gear Sockets  
 Removal; 3-197  
 Repair; 3-197  
 Replacement; 3-197  
 Lashing Gear/Towing/Mooring Equip-  
 ment; 2-6n  
 Laundry Equipment; 1-16  
 Laundry Dryer Tumbler  
 Assembly; 3-103  
 Disassembly; 3-103  
 Removal; 2-89

Subject, Paragraph

**L - CONT**

Repair; 2-89, 3-103  
 Replacement; 2-89  
 Lavatory Basin  
 Removal; 2-362  
 Repair; 2-362  
 Replacement; 2-362  
 Level Sight Indicators  
 Assembly; 3-41, 3-42  
 Disassembly; 3-41, 3-42  
 Removal; 3-41, 3-42  
 Repair; 3-41, 3-42  
 Replacement; 3-41, 3-42  
 Light  
 Blinker Light; 2-39  
 Single Lens Navigation Light  
 2-35, 2-36  
 Double Lens Navigation Light  
 2-37, 2-3  
 Linear Directional Control Valve  
 Assembly; 2-125  
 Disassembly; 2-125  
 Removal; 2-125  
 Repair; 2-125  
 Replacement; 2-125  
 Location and Description of Major  
 Components; 1-7  
 Lube Oil Purifier  
 Removal; 3-14  
 Replacement 3-14  
 Lubricating Oil System; 1-14d  
 Lubricating Oil Transfer and  
 Purification Piping System; 1-28

**M**

Machine Shop Equipment; 2-6h  
 Machinery Plant Monitoring and  
 Alarm System  
 Removal; 3-121  
 Repair; 2-127, 3-121  
 Replacement; 3-121  
 Machinery Plant Monitoring System;  
 1-12d  
 Main Propulsion System; 1-14  
 Main Switchboard; 1-11c  
 Maintenance Forms, Records, and  
 Reports; 1-2  
 Maintenance Procedures for:  
 Commissary Equipment; 2-54

INDEX - CONT

Subject, Paragraph

**M - CONT**

Control Centers/Switchboards;  
2-221, 3-200  
Controls System; 2-112, 3-115  
Doors, Hatches and Manholes/  
Windows Group; 2-204, 3-185  
Electrical System; 2-157  
Entertainment System; 2-15  
Furniture and Fixtures; 2-14  
HALON Firefighting System; 3-11  
Hulls/Miscellaneous; 2-374, 3-265  
Lashing Gear Equipment; 2-214, 3-197  
Machinery, Shop Equipment; 2-51, 3-54  
Miscellaneous Pumps and  
Motors; 2-95, 3-109  
Navigation Signals and  
Searchlights; 2-35, 3-47  
Piping System  
Bilge Ballast and  
Firemain; 2-329, 3-221  
Bilge Manifold Unit Assembly;  
3-247  
Bowthruster; 2-364, 3-255  
Compressed Air; 2-342, 3-233  
Electrical System; 3-142  
Emergency Generator; 2-368, 3-259  
Fire Monitor and Washdown; 2-345,  
3-235  
Fire Pump Unit Assembly;  
2-371, 3-264  
Foam Proportioners; 2-369, 3-262  
Fresh Water Cooling; 2-341, 3-228  
Fuel Transfer Pump Unit  
Assembly; 2-357, 3-250  
Hydraulic; 2-351, 3-242  
Lube Oil Transfer/Dirty  
Oil Discharge; 2-347, 3-238  
Oily Water Separator; 2-353, 3-246  
Potable Water; 2-319, 3-216  
Sea Water Cooling; 2-336, 3-224  
Sewage and Plumbing; 3-253  
Steering Gear; 2-366, 3-258  
Propeller Shaft Assembly; 2-305,  
3-202  
Purifiers/Separators; 2-17, 3-14  
Sound Powered Telephone; 2-31, 3-34  
System, Sewage and Plumbing;  
2-358

Subject, Paragraph

**M - CONT**

Tank Level Indicator System; 2-32,  
3-41  
Valves/Strainers; 2-308, 3-206  
Workboat, Lifeboats/Davits; 2-215,  
3-198  
Manhole  
Bolted Plate, Raised  
Removal; 2-204  
Repair; 2-204  
Replacement; 2-204  
Bolted Plate, Flush  
Removal; 2-205  
Repair; 2-205  
Replacement; 2-205  
Mechanical Transmission  
Assembly; 3-63  
Disassembly; 3-63  
Removal; 2-57  
Repair; 2-57, 3-63  
Replacement; 2-57  
Mechanical Transmission Internal  
Components  
Removal; 2-58  
Replacement; 2-58  
Modular Inflatable Liferaft  
Removal; 2-217  
Replacement; 2-217  
Motor  
Assembly; 3-73'  
Disassembly; 3-73  
Removal; 2-65  
Repair; 3-73  
Replacement; 2-65  
Motor Control Box Assembly  
Assembly; 3-23  
Disassembly; 3-23  
Removal; 2-26  
Repair; 2-26, 3-23  
Replacement; 2-26'  
Motor Control Center  
Auxiliary Machinery Vent  
Room No. 1  
Removal; 2-221, 2-232  
Repair; 2-221  
Replacement; 2-221, 2-232  
Auxiliary Machinery Vent  
Room No. 2  
Removal; 2-233, 2-246

INDEX - CONT

Subject, Paragraph

**M - CONT**

Repair; 2-233  
 Replacement; 2-233, 2-246  
 Engine Room Supply Fan  
 Assembly; 2-251  
 Disassembly; 2-251  
 Repair; 2-251  
 Engine Room Vent  
 Removal; 2-247, 2-252  
 Repair; 2-247  
 Replacement; 2-247, 2-252  
 Forward Deck Machinery  
 Removal; 2-253, 2-260  
 Repair; 2-253  
 Replacement; 2-253, 2-260  
 Motor Controller  
 Air Compressor No. 1 and No. 2  
 Assembly; 2-227  
 Disassembly; 2-227  
 Removal; 2-226  
 Repair; 2-227  
 Replacement; 2-226  
 Auxiliary Sea Water Cooling Pump  
 Assembly; 2-235  
 Disassembly; 2-235  
 Removal; 2-234  
 Repair; 2-235  
 Replacement; 2-234  
 Bilge and Ballast Pump  
 Assembly; 2-270  
 Disassembly; 2-270  
 Removal; 2-269  
 Repair; 2-270  
 Replacement; 2-269  
 Bowthruster Steering Motor  
 Assembly; 2-257  
 Disassembly; 2-257  
 Repair; 2-257  
 Removal; 2-256  
 Replacement; 2-256  
 Bowthruster Supply Fan  
 Assembly; 2-282  
 Disassembly; 2-282  
 Removal; 2-281  
 Repair; 2-282  
 Replacement; 2-281  
 Bow Windlass 1 & 2  
 Assembly; 2-255  
 Disassembly; 2-255  
 Removal; 2-254

Subject, Paragraph

**M - CONT**

Repair; 2-255  
 Replacement; 2-254  
 Clean Lube Oil Pump No. 1  
 and No. 2  
 Assembly; 2-245  
 Disassembly; 2-245  
 Removal; 2-244  
 Repair; 2-245  
 Replacement; 2-244  
 Dirty Lube Oil Pump  
 Assembly; 2-229  
 Disassembly; 2-229  
 Removal; 2-228  
 Repair; 2-229  
 Replacement; 2-228  
 Emergency Generator Room  
 Supply Fan  
 Assembly; 2-284  
 Disassembly; 2-284  
 Removal; 2-283  
 Repair; 2-284  
 Replacement; 2-283  
 Emergency Lube Oil Prelube Pump  
 Assembly; 2-223  
 Disassembly; 2-223  
 Removal; 2-222  
 Repair; 2-223  
 Replacement; 2-222  
 Test; 2-222  
 Emergency Room Supply Fan  
 Removal; 2-250  
 Replacement; 2-250  
 Engine Room Exhaust Fan  
 Removal; 2-248  
 Replacement; 2-248  
 Engine Room Supply Fan  
 Assembly; 2-251  
 Disassembly; 2-251  
 Repair; 2-251  
 Fire Pump 1 and 2  
 Assembly; 2-264  
 Disassembly; 2-264  
 Removal; 2-263  
 Repair; 2-264  
 Replacement; 2-263  
 Fresh Water Pump 1 & 2  
 Assembly; 2-268  
 Disassembly; 2-268  
 Removal; 2-267

INDEX - CONT

Subject, Paragraph

M - CONT

Repair; 2-268  
 Replacement; 2-267  
 Fuel Oil Transfer Pump No. 2  
 Assembly; 2-272  
 Disassembly; 2-272  
 Removal; 2-271  
 Repair; 2-272  
 Replacement; 2-271  
 Galley Duct Heater  
 Assembly; 2-290  
 Disassembly; 2-290  
 Removal; 2-289  
 Repair; 2-290  
 Replacement; 2-289  
 Galley Exhaust Fan  
 Assembly; 2-274  
 Disassembly; 2-274  
 Removal; 2-273  
 Repair; 2-274  
 Replacement; 2-273  
 Galley Makeup Supply Fan  
 Assembly; 2-286  
 Disassembly; 2-286  
 Removal; 2-285  
 Repair; 2-286  
 Replacement; 2-285  
 Galley Vent Hood Fan  
 Assembly; 2-288  
 Disassembly; 2-288  
 Removal; 2-287  
 Repair; 2-288  
 Replacement; 2-287  
 Lavatory Exhaust Fan  
 Assembly; 2-276  
 Disassembly; 2-276  
 Removal; 2-275  
 Repair; 2-276  
 Replacement; 2-275  
 Lube Oil Purifier  
 Assembly; 2-241  
 Disassembly; 2-241  
 Removal; 2-240  
 Repair; 2-241  
 Replacement; 2-240  
 Lube Oil Purifier Heater  
 Assembly; 2-239  
 Disassembly; 2-239  
 Removal; 2-238  
 Repair; 2-239

Subject, Paragraph

M - CONT

Replacement; 2-238  
 Test; 2-238  
 Lube Oil Transfer Pump No. 1  
 Assembly; 2-237  
 Disassembly; 2-237  
 Repair; 2-237  
 Removal; 2-236  
 Replacement; 2-236  
 Main Engine Jacket Water  
 Heater No. 1 and No. 2  
 Assembly; 2-231  
 Disassembly; 2-231  
 Removal; 2-230  
 Repair; 2-231  
 Replacement; 2-230  
 Multi-Remote Module  
 Assembly; 2-141  
 Disassembly; 2-141  
 Removal; 3-132  
 Repair; 2-141, 3-132  
 Replacement; 3-132  
 Reduction Gear Cooling Water  
 Pump No. 1 and No. 2  
 Assembly; 2-243  
 Disassembly; 2-243  
 Removal; 2-242  
 Repair; 2-243  
 Replacement; 2-242  
 Steering Gear Exhaust Fan  
 Assembly; 2-278  
 Disassembly; 2-278  
 Removal; 2-277  
 Repair; 2-278  
 Replacement; 2-277  
 Steering Gear Hydraulic Pump  
 Assembly; 2-266  
 Disassembly; 2-266  
 Removal; 2-265  
 Repair; 2-266  
 Replacement; 2-265  
 Stern Windlass  
 Assembly; 2-262  
 Disassembly; 2-262  
 Removal; 2-261  
 Repair; 2-262  
 Replacement; 2-261  
 Test; 2-261  
 Tunnel Supply Fan  
 Assembly; 2-280

INDEX - CONT

Subject, Paragraph

M - CONT

Disassembly; 2-280  
 Removal; 2-279  
 Repair; 2-280  
 Replacement; 2-279  
 Motorized Oil Pump Assembly  
 Assembly; 4-20  
 Disassembly; 4-20  
 Repair; 4-20  
 Motorized Water Pump Assembly  
 Assembly; 4-21  
 Disassembly; 4-21  
 Repair; 4-21

N

Navigation Light (Forward Anchor  
 Light, Not Under Command Light-  
 Upper, Not Under Command  
 Light-Lower, Aft Anchor Light)  
 Assembly; 2-36  
 Disassembly; 2-36  
 Removal; 2-35  
 Repair; 2-36  
 Replacement; 2-35  
 Navigation Light (Forward Masthead  
 Light, Aft Masthead Light,  
 Starboard Sidelight, Port  
 Sidelight, Stern Light)  
 Assembly; 2-38  
 Disassembly; 2-38  
 Removal; 2-37  
 Repair; 2-38  
 Replacement; 2-37  
 Navigation Lighting System; 1-19  
 Navigation System; 2-6g  
 Normal Startup; 2-8, 4-6

O

Oil Pump/Motor Assembly  
 Removal; 3-31  
 Replacement; 3-31  
 Oil/Water Separator  
 Assembly; 3-22  
 Disassembly; 3-22  
 Removal; 3-21  
 Repair; 3-22  
 Replacement; 3-21  
 Oily Water Separator Piping System;  
 1-29

Subject, Paragraph

O - CONT

Omnidirectional Antenna  
 Assembly; 2-16  
 Disassembly; 2-16  
 Repair; 2-16  
 Outboard Motor  
 Assembly; 2-216  
 Disassembly; 2-216  
 Inspection; 2-216  
 Removal; 2-216  
 Repair; 2-216  
 Replacement; 2-216  
 Oscillator Unit  
 Removal; 2-50  
 Repair; 2-50  
 Replacement; 2-50

P

Pilothouse Air Condition Power  
 Distribution  
 Removal; 3-152  
 Repair; 3-152  
 Replacement; 3-152  
 Pilothouse Battery Assembly  
 Removal; 2-196  
 Repair; 2-196, 3-181  
 Replacement; 2-196  
 Pilothouse Battery Assembly  
 Charger  
 Removal; 2-197  
 Repair; 2-197, 2-344, 2-350  
 Replacement; 2-197  
 Pilothouse Console (PHC); 1-12b  
 Pinon Shaft Group  
 Assembly; 3-67  
 Disassembly; 3-67  
 Repair; 3-67  
 Pipe Hangers  
 Removal; 3-223, 3-227,  
 3-232, 3-234, 3-237,  
 3-240, 3-244, 3-246,  
 3-249, 3-252, 3-257,  
 3-261, 3-263, 3-265  
 Repair; 3-223, 3-227,  
 3-232, 3-234, 3-237,  
 3-240, 3-244, 3-246,  
 3-249, 3-252, 3-257,  
 3-261, 3-263, 3-265

INDEX - CONT

Subject, Paragraph

**P - CONT**

Replacement; 3-223, 3-227,  
 3-232, 3-234, 3-237,  
 3-240, 3-244, 3-246,  
 3-249, 3-252, 3-257,  
 3-261, 3-263, 3-265

Piping; 2-65

Piping Gauge Assembly  
 Removal; 2-335, 2-340  
 Repair; 2-335, 2-340, 2-344,  
 2-350, 2-355, 2-356  
 Replacement; 2-335, 2-340

Plate Assembly  
 Assembly; 3-26  
 Disassembly; 3-26  
 Removal; 3-26  
 Repair; 3-26  
 Replacement; 3-26

PMCS; 3-7, 4-8'

Portable Davit  
 Assembly; 2-220  
 Disassembly; 2-220  
 Removal; 2-220  
 Repair; 2-220  
 Replacement; 2-220

Power Distribution  
 120V  
 Removal; 2-77  
 Repair; 3-165  
 Replacement; 2-177

240V  
 Removal; 2-157  
 Repair; 2-157, 3-142  
 Replacement; 2-157

Power Distribution Panel  
 EL102  
 Removal; 2-186  
 Repair; 2-186, 3-173  
 Replacement; 2-186

EP024 SECT B  
 Removal; 2-192  
 Repair; 3-177  
 Replacement; 2-192

EP024-1  
 Removal; 2-191  
 Repair; 3-177  
 Replacement; 2-191

EP103  
 Removal; 2-188

Subject, Paragraph

**P - CONT**

Replacement; 2-188

L102  
 Removal; 2-179  
 Repair; 2-179, 3-167  
 Replacement; 2-179

L104  
 Removal; 2-180  
 Repair; 2-180, 3-168  
 Replacement; 2-180

L105  
 Removal; 2-181  
 Repair; 2-181, 3-169  
 Replacement; 2-181

PO1  
 Removal; 2-178  
 Repair; 2-178, 3-166  
 Replacement; 2-178

P106  
 Removal; 2-183  
 Repair; 2-183, 3-170  
 Replacement; 2-183

P201  
 Removal; 2-159  
 Repair; 2-159, 3-143  
 Replacement; 2-159

Galley P202  
 Removal; 2-160  
 Repair; 2-160, 3-144  
 Replacement; 2-160

Panel P203  
 Removal; 2-161  
 Repair; 2-161, 3-145  
 Replacement; 2-161

Panel P204  
 Removal; 2-162  
 Repair; 2-162, 3-146  
 Replacement; 2-162

Panel P211  
 Removal; 2-167  
 Repair; 2-167, 3-151  
 Replacement; 2-167

Power Generation System; 1-1

Power Supply  
 Assembly; 2-46  
 Disassembly; 2-46  
 Removal; 2-45  
 Repair; 2-46  
 Replacement; 2-45

Preoperative Checks; 2-6



## INDEX - CONT

Subject, Paragraph

**P - CONT**

Preparation for Storage or Shipment;  
1-5, 2-382, 3-269, 4-25

Pressure Switches; 1-22b

Pressure Switch  
Removal; 2-322  
Repair; 2-322, 2-343  
Replacement; 2-322

Pressure Switch Assembly  
Adjustment; 2-24  
Removal; 2-24  
Replacement; 2-24

Pressure Tank; 1-22c

Principles of Operation; 1-10

Propeller Shaft; 2-6g

Propeller Shaft Assembly  
Assembly; 3-202  
  
Disassembly; 3-202  
Inspection; 2-305  
Removal; 4-23  
Repair; 3-202, 4-23  
Replacement; 4-23  
Test; 2-305

Propeller Shaft, Propeller, and Shaft  
Brake; 1-31

Pump Connection Assembly  
Assembly; 2-18  
Disassembly; 2-18  
Repair; 2-18

Purifier Hood Assembly  
Removal; 2-20  
Replacement; 2-20

Purifier/Separators; 2-6d

**R**

Receiver Module, RE 31326  
Assembly; 3-46  
Disassembly; 3-46  
Removal; 2-34, 3-46  
Repair; 2-34, 3-46  
Replacement; 2-34, 3-46

Receiver Module, RE-39240  
Assembly; 3-44  
Disassembly; 3-44  
Removal; 2-32, 3-44  
Repair; 2-32, 3-44  
Replacement; 2-32, 3-44

Receiver Module, RE-39260  
Assembly; 3-45  
Disassembly; 3-45

Subject, Paragraph

**R - CONT**

Removal; 2-33, 3-45  
Repair; 2-33, 3-45  
Replacement; 2-33, 3-45

Refrigerator, R-20 Mechanical  
Assembly; 3-76  
Disassembly; 3-76  
Removal; 2-68  
Repair; 2-68, 3-76  
Replacement; 2-68

Refrigeration Condenser  
Assembly; 3-77  
Disassembly; 3-77  
Removal; 2-69  
Repair; 3-77  
Replacement; 2-69

Refrigeration Evaporator Coil  
Assembly; 3-78  
Disassembly; 3-78  
Removal; 2-70  
Repair; 3-78  
Replacement; 2-70

Refrigerator, R-30 Mechanical, Food  
Assembly 3-84  
Disassembly; 3-84  
Removal; 2-76  
Repair; 2-76, 3-84  
Replacement; 2-76

Refrigeration Condenser  
Assembly; 3-85  
Disassembly; 3-85  
Removal; 2-77  
Repair; 3-85  
Replacement; 2-77

Refrigeration Evaporator Coil  
Assembly; 3-86  
Disassembly; 3-86  
Removal; 2-78  
Repair; 3-86  
Replacement; 2-78

Remote Foot Control  
Removal; 2-52  
Repair; 2-52  
Replacement; 2-52

Repair Parts; 2-3, 3-3, 4-3

Reporting Equipment Improvement  
Recommendations; 1-4

Rotary Hand Pump  
Removal; 2-333, 3-241  
Repair; 2-333, 3-241  
Replacement; 2-333, 3-241

## INDEX - CONT

Subject, Paragraph	Subject, Paragraph
<b>R - CONT</b>	<b>S</b>
Rotary Pump	Safety, Care, and Handling; 1-9
Dirty Lubricate Oil	Scope; 1-1
Assembly; 3-113	Searchlight
Disassembly; 3-113	Removal; 3-47
Removal; 2-108	Repair; 3-47
Repair; 2-108, 3-113	Replacement; 3-47
Replacement; 2-108	Searchlight
Fuel Oil Transfer	Control Station
Assembly; 3-113	Assembly; 3-53
Disassembly; 3-113	Disassembly; 3-53
Removal; 2-102	Removal; 3-53
Repair; 3-113	Repair; 3-53
Replacement; 2-102	Replacement; 3-53
Prelubricate Oil Transfer	Lever Gear Assembly
Assembly; 3-113	Assembly; 3-52
Disassembly; 3-113	Disassembly; 3-52
Removal; 2-105	Repair; 3-52
Repair; 2-105, 3-113	Manual Lever Control
Replacement; 2-105	Assembly; 3-51
Rotary Pump Unit	Disassembly; 3-51
Dirty Lubricate Oil	Repair; 3-51
Assembly; 3-112	Power Supply
Disassembly; 3-112	Assembly; 3-50
Removal; 2-107	Disassembly; 3-50
Repair; 2-107, 3-112	Removal; 3-50
Replacement; 2-107	Repair; 3-50
Fuel Oil Transfer	Replacement; 3-50
Assembly; 3-112	Starter Assembly
Disassembly; 3-112	Assembly; 3-49
Removal; 2-101	Disassembly; 3-49
Repair; 2-101, 3-112	Removal; 3-49
Replacement; 2-101	Repair; 3-49
Prelubricate Oil Transfer	Replacement; 3-49
Assembly; 3-112	Seawater Cooling Piping System; 1-24
Disassembly; 3-112	Sediment Strainer
Removal; 2-104	Assembly; 2-23
Repair; 2-104, 3-112	Disassembly; 2-23
Replacement; 2-104	Repair; 2-23
Rotary Switch	Service; 2-22
Assembly; 2-49	Self-Heating Griddle
Disassembly; 2-49	Assembly; 3-61
Removal; 2-49	Disassembly; 3-61
Repair; 2-49	Removal; 2-55
Replacement; 2-49	Repair; 3-61
Rudder Indicator	Replacement; 2-55
Assembly; 2-114, 3-118	Sensing Module Assembly
Disassembly; 2-114, 3-118	Removal; 3-33
Removal; 3-118	Replacement; 3-33
Repair; 2-114, 3-118	Sensor Manifold
Replacement; 3-118	Assembly; 4-22

INDEX - CONT

Subject, Paragraph

**S - CONT**

Disassembly; 4-22  
 Repair; 4-22  
 Sequential Timer  
   Assembly; 2-48  
   Disassembly; 2-48  
   Removal; 2-47  
   Repair; 2-48  
   Replacement; 2-47  
 Service Sink  
   Removal; 2-363  
   Repair; 2-363  
   Replacement; 2-363  
 Sewage Piping System; 1-30  
 Shifter Yoke Assembly  
   Assembly; 3-66  
   Disassembly; 3-66  
   Repair; 3-66  
 Shipboard Alarm Panel  
   Removal; 3-141  
   Repair; 3-141  
   Replacement; 3-141  
 Ship Service Switchboard  
   Removal; 3-200  
   Repair; 3-200  
   Replacement; 3-200  
 Circuit Breakers  
   Assembly; 2-296  
   Disassembly; 2-296  
   Removal; 2-291  
   Repair; 2-291, 2-296  
   Replacement; 2-291  
   Test; 2-291, 2-296  
 Current Transformers  
   Assembly; 2-295  
   Disassembly; 2-295  
   Repair; 2-295  
   Test; 2-295  
 Fuse Panel  
   Assembly; 2-297  
   Disassembly; 2-297  
   Repair; 2-297  
   Test; 2-297  
 Indicators Gauges, Meters,  
 Switches, Variable Resistor,  
 Rheostat, Circuit Breaker  
   Assembly; 2-294  
   Disassembly; 2-294  
   Repair; 2-294  
   Test; 2-294  
 Indicators, Meters, Switches and Circuit Breaker

Subject, Paragraph

**S - CONT**

Assembly; 2-292  
 Disassembly; 2-292  
 Repair; 2-292  
 Test; 2-292  
 Indicators, Meters, Switches, Vari-  
 able Resistor, Rheostat and  
 Circuit Breaker  
   Assembly; 2-293  
   Disassembly; 2-293  
   Repair; 2-293  
   Test; 2-293  
 Shipboard Alarm Panel  
   Assembly; 2-153  
   Disassembly; 2-153  
   Removal; 3-141  
   Repair; 2-153, 3-141  
   Replacement; 3-141  
 Ship's Service Diesel Generator  
   Engine; 1-11a  
 Ship's Service Generator; 1-11b  
 Shore Power Box; 1-11e  
 Shore Power Supply Assembly  
   Removal; 2-158  
   Repair; 2-158  
   Replacement; 2-158  
 Shower Safety Unit  
   Removal; 2-326  
   Repair; 2-326  
   Replacement; 2-326  
 Shutdown Procedure (Usual or  
 Unusual); 2-9, 4-7  
 Sound Powered Telephone System; 1-20  
 Sound Powered Telephone  
   Removal; 2-31  
   Repair; 2-31  
   Replacement; 2-31  
 MWT-R-8  
   Assembly; 3-39  
   Disassembly; 3-39  
   Repair; 3-39  
 MWT-R-19  
   Assembly; 3-38  
   Disassembly; 3-38  
   Repair; 3-38  
 SELR (MOD)-8  
   Assembly; 3-37  
   Disassembly; 3-37  
   Repair; 3-37

INDEX - CONT

Subject, Paragraph

**S - CONT**

SELR (MOD)-19  
 Assembly; 3-35  
 Disassembly; 3-35  
 Repair; 3-35  
 SER (MOD)-8  
 Assembly; 3-36  
 Disassembly; 3-36  
 Repair; 3-36  
 SER (MOD)-19  
 Assembly; 3-34  
 Disassembly; 3-34  
 Repair; 3-34  
 SFLR (MOD)-19  
 Assembly; 3-40  
 Disassembly; 3-40  
 Repair; 3-40  
 Special Tools (TMDE), and Support  
 Equipment; 2-2, 3-2, 4-2  
 Startup and Shutdown; 3-6  
 Steering Control and Autopilot  
 System  
 Inspection; 3-115  
 Removal; 3-115  
 Repair; 2-112, 3-115  
 Replacement; 3-115  
 Steering Control Panel; 1-12f  
 Steering Control Panel Assembly  
 Assembly; 2-113, 2-155, 3-116  
 Disassembly; 2-113, 2-155,  
 3-116  
 Removal; 2-155, 3-116  
 Repair; 2-113, 2-155, 3-116  
 Replacement; 2-155, 3-116  
 Steering Gear, Port, Power  
 Distribution  
 Removal; 3-162  
 Repair; 3-162  
 Replacement; 3-162  
 Steering Gear Room; 1-25c  
 Stern Anchor Winch Power  
 Distribution  
 Repair; 3-158  
 Stern Winch Anchor Power  
 Distribution; 2-171  
 Strainer  
 2-1/2-Inch Sediment Strainer Basket  
 Assembly; 2-317

Subject, Paragraph

**S - CONT**

Disassembly; 2-317  
 Removal; 2-317  
 Repair; 2-317, 3-214  
 Replacement; 2-317  
 3-Inch Duplex Sediment  
 Assembly, 2-318  
 Disassembly; 2-318  
 Removal; 2-318  
 Repair; 2-318, 3-215  
 Replacement; 2-318  
 4-Inch Sediment Strainer Basket  
 Assembly; 2-315  
 Disassembly; 2-315  
 Removal; 2-315  
 Repair; 2-315, 3-212  
 Replacement; 2-315  
 5-Inch Simplex Sediment  
 Assembly; 2-313  
 Disassembly; 2-313  
 Removal; 2-313  
 Repair; 2-313, 3-210  
 Replacement; 2-313  
 5-Inch Sediment Strainer Basket  
 Assembly; 2-316  
 Disassembly; 2-316  
 Removal; 2-316  
 Replacement; 2-316  
 Repair; 2-316, 3-213  
 8-Inch Simplex Sediment  
 Assembly; 2-314  
 Disassembly; 2-314  
 Removal; 2-314  
 Repair; 2-314, 3-211  
 Replacement; 2-314  
 Sun Shaft Group  
 Assembly; 3-65  
 Disassembly; 3-65  
 Repair; 3-65  
 Symptom Index; 2-11, 3-8, 4-9  
 System Pressure Regulating Valve  
 Assembly; 2-122  
 Disassembly; 2-122  
 Removal; 2-122  
 Repair; 2-122  
 Replacement; 2-122

INDEX - CONT

Subject, Paragraph

T

Tank Arrangement  
 Assembly; 4-24  
 Disassembly; 4-24  
 Removal; 4-24  
 Repair; 4-24  
 Replacement; 4-24  
 Tank Level Indicator System 2-6f  
 Tank Level Indicator Transmitters;  
 1-22g  
 Troubleshooting; 2-12, 3-9, 4-10  
 Two Station Twin Engine with  
 Bowthruster and Fire Control System  
 Inspection; 2-116  
 Removal; 2-116  
 Repair; 2-116  
 Replacement; 2-116

U

Urinal; 2-361  
 Removal; 2-361  
 Repair; 2-361  
 Replacement; 2-361

V

Valves  
 2-1/2-Inch Stop Check Angle  
 Assembly; 3-206  
 Disassembly; 3-206  
 Removal; 2-308  
 Repair; 2-308, 3-206  
 Replacement; 2-308  
 4-Inch Swing Check Valve  
 Assembly; 3-209  
 Disassembly; 3-209  
 Removal; 2-312  
 Repair; 3-209  
 Replacement; 2-312  
 4-Inch Three-Way Ball  
 Assembly; 2-310, 3-207, 3-208  
 Disassembly; 2-310, 3-207, 3-208  
 Removal; 2-309, 2-310  
 Repair; 2-310, 3-207, 3-208  
 Replacement; 2-309, 2-310  
 Butterfly  
 Removal; 2-332, 3-229  
 Repair; 2-332, 2-339, 2-346,  
 2-370, 2-373, 3-229  
 Replacement; 2-332, 3-229  
 Fittings  
 Removal; 2-320

Subject, Paragraph

V - CONT

Repair; 2-320  
 Replacement; 2-320  
 Flanged  
 Removal; 2-330, 3-222, 3-230  
 Repair; 2-331, 2-338, 2-348,  
 2-359, 2-365, 2-374, 3-222,  
 3-230  
 Replacement; 2-330, 3-222, 3-230  
 Flush  
 Removal; 2-327  
 Repair; 2-327  
 Replacement; 2-327  
 Threaded  
 Removal; 3-224  
 Repair; 2-319, 2-329, 2-336, 2-342,  
 2-348, 2-351, 2-353, 2-357,  
 2-366, 2-371, 3-224  
 Replacement; 3-224  
 Threaded Fittings  
 Removal; 2-320  
 Repair; 2-320, 2-334, 2-339, 2-341  
 2-346, 2-349, 2-352, 2-354,  
 2-359, 2-365, 2-367, 2-368,  
 2-370  
 Repair; 2-320; 2-334, 2-339, 2-341,  
 Replacement; 2-320  
 Valve Strainer; 2-6r  
 Vent  
 Removal; 3-228, 3-231, 3-238, 3-242,  
 Repair; 3-216, 3-238, 3-245  
 Replacement; 3-216, 3-238, 3-245  
 Welded  
 Removal; 3-228, 3-231, 3-238, 3-242,  
 3-247, 3-250, 3-253,  
 3-255, 3-259  
 Repair; 3-228, 3-242,  
 3-247, 3-250, 3-253,  
 3-255, 3-259  
 Replacement; 3-228, 3-242,  
 3-247, 3-250, 3-253,  
 3-255, 3-259  
 Vertical Gear Assembly  
 Assembly; 4-14  
 Disassembly; 4-14  
 Removal; 3-17  
 Repair; 4-14  
 Replacement; 3-17  
 Vessel Subassembly  
 1st Stage  
 Assembly; 3-25  
 Disassembly; 3-25  
 Removal; 3-24

INDEX - CONT

Subject, Paragraph

Subject, Paragraph

V - CONT

W - CONT

- Repair; 3-25
- Replacement; 3-24
- 2nd Stage
  - Assembly; 2-30, 3-30
  - Disassembly; 2-30, 3-30
  - Removal; 3-29
  - Repair; 2-30, 3-30
  - Replacement; 3-29
- 3rd Stage
  - Assembly; 2-29, 3-28
  - Disassembly; 2-29, 3-28
  - Removal; 3-27
  - Repair; 2-29, 3-28
  - Replacement; 3-27

- Repair; 3-102
- Removal; 2-88
- Replacement; 2-88
- Washer Machine Outer Tube, Cover, and Pressure Hose Group
  - Repair; 3-95
- Washer Machine Transmission Group
  - Repair; 3-98
- Washer Machine Water Mixing Valve
  - Assembly; 3-93
  - Disassembly; 3-93
  - Removal; 2-84
  - Repair; 2-84, 3-93
  - Replacement; 2-84
- Washer Pump and Hoses Group
  - Removal; 2-87, 3-93
  - Repair; 3-100
  - Replacement; 2-87
- Water Closet
  - Removal; 2-360
  - Repair; 2-360
  - Replacement; 2-360
- Water Heater Disconnect Switch
  - Removal; 2-168
  - Repair; 2-168
  - Replacement; 2-168
- Water Heater Power Distribution
  - Removal; 3-155
  - Repair; 3-155
  - Replacement; 3-155
- Water Pump/Motor Assembly
  - Removal; 3-32
  - Replacement; 3-32
- Watertight Doors
  - 30 x 51
    - Assembly; 3-186
    - Disassembly; 3-186
    - Repair; 3-186
  - 30 x 51 (with Fixed Light)
    - Assembly; 3-185
    - Disassembly; 3-185
    - Repair; 3-185
  - Four Dogs (30 x 51)
    - Assembly; 2-207
    - Disassembly; 2-207
    - Removal; 2-207
    - Repair; 2-207
    - Replacement; 2-207
  - Four Dogs (30 x 51) (With Fixed Light)
    - Assembly; 2-206

W

- Washer Machine
  - Adjustment; 2-83
  - Assembly; 3-92
  - Disassembly; 3-92
  - Removal; 2-83
  - Repair; 2-83, 3-92
  - Replacement; 2-83
- Washer Machine Agitator Post Assembly
  - Assembly; 3-94
  - Disassembly; 3-94
  - Removal; 2-85
  - Repair; 3-94
  - Replacement; 2-85
- Washer Machine Bearing Housing, Brake/Pulley Pivot
  - Repair; 3-97
- Washer Machine Centrifugal Pump
  - Assembly; 3-101
  - Disassembly; 3-101
  - Repair; 3-101
- Washer Machine Internal Components
  - Removal; 2-86
  - Replacement; 2-86
- Washer Machine Lint Filter, Wash Tub, and Hub Group
  - Repair; 3-96
- Washer Machine Mechanical Transmission
  - Assembly; 3-99
  - Disassembly; 3-99
  - Repair; 3-99
- Washer Machine Motor and Idler
  - Adjustment; 2-88

INDEX - CONT

Subject, Paragraph

W - CONT

Disassembly; 2-206  
 Removal; 2-206  
 Repair; 2-206  
 Replacement; 2-206  
 Four Dogs (30 x 60)  
 Assembly; 2-210, 3-189  
 Disassembly; 2-210, 3-189  
 Removal; 2-210  
 Repair; 2-210, 3-189  
 Replacement; 2-210  
 Quick Action, Left Hand  
 (30 x 66)  
 Assembly; 2-208, 3-187  
 Disassembly; 2-208, 3-187  
 Removal; 2-208  
 Repair; 2-208, 3-187  
 Replacement; 2-208  
 Six Dogs (30 x 60)  
 Assembly; 2-209, 3-188  
 Disassembly; 2-209, 3-188  
 Removal; 2-209  
 Repair; 2-209, 3-188  
 Replacement; 2-209  
 Watertight Hatch, Quick Action  
 Assembly; 2-211, 3-190  
 Disassembly; 2-211, 3-190  
 Removal; 2-211  
 Repair; 2-211, 3-190  
 Replacement; 2-211  
 Watertight Scuttle, Quick Action  
 Flush  
 Assembly; 2-212, 3-191  
 Disassembly; 2-212, 3-191  
 Removal; 2-212  
 Repair; 2-212, 3-191  
 Replacement; 2-212  
 Raised  
 Assembly; 2-213, 3-192  
 Disassembly; 2-213, 3-192  
 Removal; 2-213  
 Repair; 2-213, 3-192  
 Replacement; 2-213

Subject, Paragraph

W - CONT

Welded Bar, Angles and Bar  
 Round Plates  
 Removal; 3-226  
 Repair; 3-226  
 Replacement; 3-226  
 Welded Fittings  
 Removal; 3-217, 3-221,  
 3-225, 3-231, 3-233, 3-236,  
 3-239, 3-243, 3-248, 3-251,  
 3-254, 3-256, 3-258, 3-260,  
 3-262, 3-264  
 Repair; 3-217, 3-221,  
 3-224, 3-231, 3-233, 3-236,  
 3-239, 3-243, 3-248, 3-251,  
 3-254, 3-256, 3-258, 3-260,  
 3-262, 3-264  
 Replacement; 3-217, 3-221,  
 3-224, 3-231, 3-233, 3-236,  
 3-239, 3-243, 3-248, 3-251,  
 3-254, 3-256, 3-258, 3-260,  
 3-262, 3-264  
 Welder Disconnect Switch  
 Removal; 2-175  
 Replacement; 2-175  
 Welder Power Distribution  
 Repair; 3-161  
 Replacement; 2-174  
 Winch, Bow Ramp, Power  
 Distribution  
 Removal; 3-164  
 Repair; 3-164  
 Replacement; 3-164  
 Winch Assembly  
 Assembly; 2-219, 3-199  
 Disassembly; 2-219, 3-199  
 Removal; 3-199  
 Repair; 2-219, 3-199  
 Replacement; 3-199  
 Windows/Door/Hatches; 2-6m  
 Workboat/Liferafts; 1-33  
 Workboat/Liferafts/Davit; 2-60

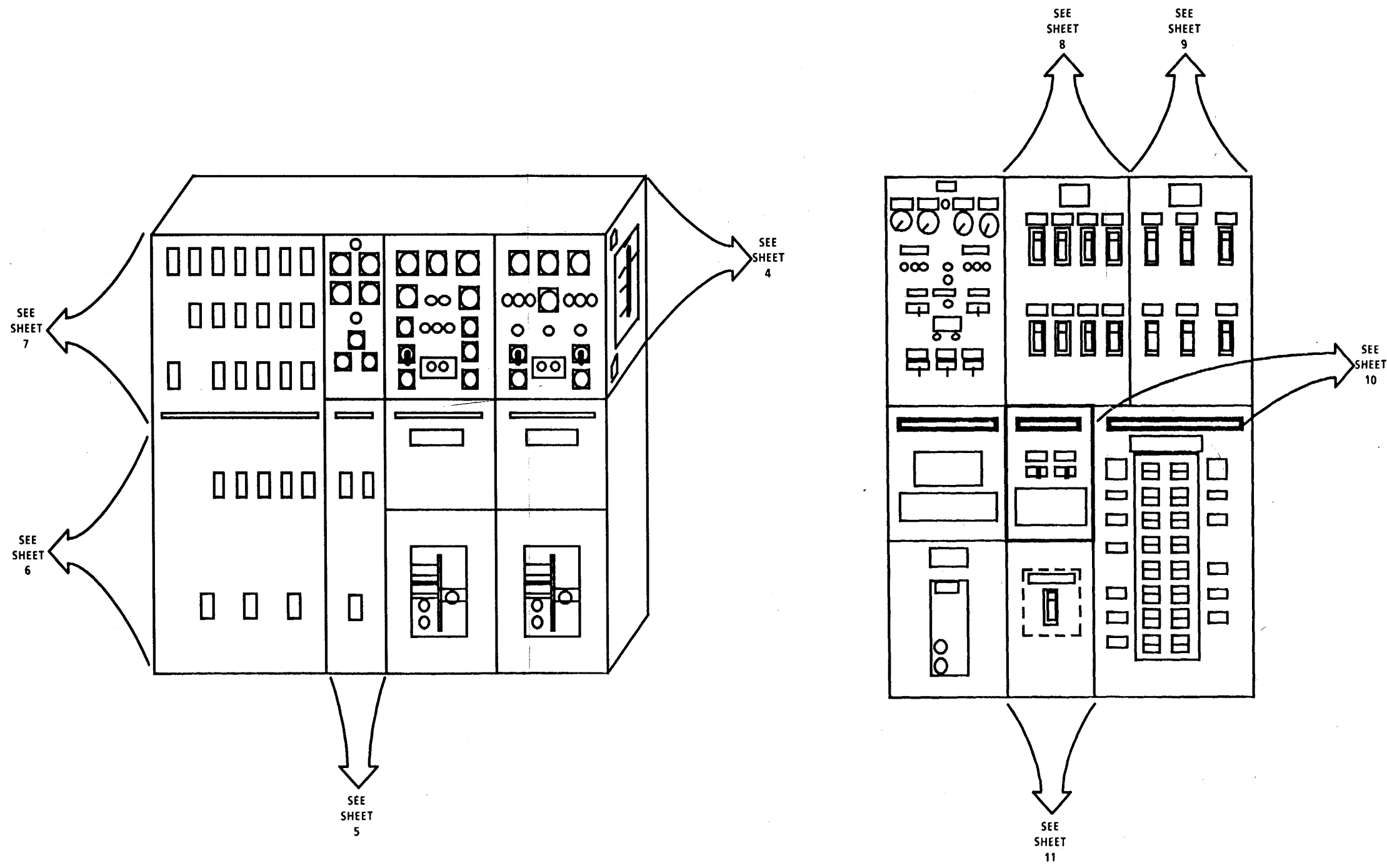

PANEL	POWER SOURCE	PANEL LOCATION	PANEL DESCRIPTION	SHEET
MAIN SWBD	EMERG SWBD SSG/SHORE PWR	ENGINE ROOM OPERATING STATION	SHIPS SERVICE (MAIN) SWITCHBOARD	4 THROUGH 7
EMERG SWBD	EMERG GEN/ MAIN SWBD	EMERGENCY GENERATOR ROOM	EMERGENCY SWITCHBOARD	8 THROUGH 11
FWD DK MACH MCC	MAIN SWBD	TUNNEL	FORWARD DECK MACHINERY MOTOR CONTROL CENTER	13
AUX MACH MCC	MAIN SWBD	ENGINE ROOM (FWD)	AUXILIARY MACHINERY MOTOR CONTROL CENTER	12
ENG RM VENT MCC	MAIN SWBD	ENGINE ROOM (FWD)	ENGINE ROOM VENTILATION MOTOR CONTROL CENTER	13
EL 102	EMERG SWBD	COMMUNICATIONS AREA	WHEELHOUSE EMERGENCY LIGHTING PANEL	10 & 15
EP 103	EMERG SWBD	COMMUNICATIONS AREA	WHEELHOUSE IC/ELEC PANEL	10 & 15
L102	MAIN SWBD	ENGINE ROOM (AFT)	ENGINE ROOM LIGHTING PANEL	4 & 16
L104	MAIN SWBD	STBD PASSAGEWAY NEAR SICKBAY	MAIN DECK LIGHTING PANEL	4 & 16
L105	MAIN SWBD	COMMUNICATIONS AREA	WHEELHOUSE LIGHTING PANEL	4 & 16
P101	MAIN SWBD	ENGINE ROOM (PORT)	QUARTERS HEATER PANEL	4 & 17
P106	MAIN SWBD	GALLEY	GALLEY 120V PANEL	4 & 17
P201	MAIN SWBD	BOWTHRUSTER COMPARTMENT (FWD)	FORWARD HEATER POWER PANEL	7 & 18
P202	MAIN SWBD	GALLEY	GALLEY POWER PANEL	6 & 18
P203	MAIN SWBD	ENGINE ROOM (AFT)	MACHINERY SPACES HEATER PANEL	7 & 18
P204	MAIN SWBD	ENGINE ROOM (AFT)	MISCELLANEOUS MACHINERY POWER PANEL	7 & 19
P211	MAIN SWBD	TUNNEL (FWD)	MACHINERY SPACES VENTILATION PANEL	7 & 19
SHORE POWER TERMINAL BOX	SHORE POWER	01 LEVEL (AFT)	SHORE POWER SUPPLY CONNECTION	5
WATER HEATER DISCONNECT	MAIN SWBD	EOS TOP	DISCONNECT SWITCH FOR WATER HEATER	7
WELDER DISCONNECT	MAIN SWBD	MACHINE SHOP	DISCONNECT SWITCH FOR WELDER	7
EP024-1	EMERG SWBD	COMMUNICATIONS AREA	24V EMERGENCY POWER DISTRIBUTION PANEL	9
EP024 SECT B	EMERG SWBD	EOS AFT	24V EMERGENCY POWER DISTRIBUTION PANEL	9
NAV LTG PANEL	EL102	PILOTHOUSE	NAVIGATION LIGHTING PANEL	15

FO-1. Power Distribution (Sheet 1 of 19)  
FP-1/(FP-2 blank)





POWER SOURCE	CIRCUIT DESCRIPTION	POWER SOURCE	CIRCUIT DESCRIPTION	POWER SOURCE	CIRCUIT DESCRIPTION	POWER SOURCE	CIRCUIT DESCRIPTION	POWER SOURCE	CIRCUIT DESCRIPTION
	- M -		- P -		- R -		- S -		- W -
P203/1 MAIN SWBD MAIN SWBD EPO24-1F MAIN SWBD AUX MACH MCC AUX MACH MCC EPO24/B-12 EPO24/B-11 EMERG SWBD P204/2 L104/10 P101/5 P106/2 P202/7 P106/14 MAIN SWBD P106/3 P106/3 EPO24-1D EP103/1 EP103/4 EMERG SWBD	MACHINE SHOP UNIT HEATER MACHINERY SPACES HEATER POWER PANEL (P203) MACHINERY SPACES VENTILATION PANEL (P211) MAGNETIC COMPASS LIGHTING MAIN DECK LIGHTING PANEL (L104) MAIN ENGINE JACKET WATER HEATER NO. 1 (STBD) MAIN ENGINE JACKET WATER HEATER NO. 2 (PORT) MAIN ENGINE (PORT) MAIN ENGINE (STBD) MAIN SWITCHBOARD BUS TIE MARINE SANITATION DEVICE MESS DECK DRINKING FOUNTAIN MESS RECREATION DUCT HEATERS MESS REFRIGERATOR MICROWAVE MILK DISPENSER MISCELLANEOUS MACHINERY POWER PANEL (P204) MIXER MIXER/SLICER MK 27 GYRO POWER TRANSFER UNIT MK 27 GYRO PWR CONV UNIT MK 37 HEADING XMTR MSR 6212 POWER SUPPLY	AUX MACH MCC EPO24/B-14 EPO24/B-9 AUX MACH MCC MAIN SWBD P106/14 P211-11 AUX MACH MCC	PORT MAIN ENGINE JACKET WATER HEATER NO. 2 PORT SHAFT TACHOMETER PORT SSDG PORT SSDG JACKET WATER HEATER NO. 2 PORT STEERING GEAR POST MIX DISPENSER PRE-HEATER - GALLEY DUCT PRE-LUBE PUMP	L102/1 L104/3 L105/7 AUX MACH MCC AUX MACH MCC P106/4 P106/6 L104/9 L104/8 P106/2 L104/12 EL102/14 EP103/14	RECEPTACLES - WORKSHOP RECEPTACLES - EMERGENCY GENERATOR ROOM (STBD) RECEPTACLES - WHEEL HOUSE REDUCTION GEAR COOLING WATER PUMP NO. 1 REDUCTION GEAR COOLING WATER PUMP NO. 2 REFRIGERATOR - 20 CUBIC FOOT REFRIGERATOR - 30 CUBIC FOOT REFRIGERATOR - CHIEF ENGINEER'S REFRIGERATOR - MASTER'S REFRIGERATOR - MESS DECK REFRIGERATOR - SICKBAY ROTARY WINDOW WIPERS RPX 150 BATTERY CHARGER	EMERG SWBD EPO24-1E EMERG SWBD P203/4 MAIN SWBD P211/6 MAIN SWBD L105/1 P203/6 EL102/2 P211/3 P211/10 P211/9 P211/2	STBD STEERING GEAR STEERING CONTROL CONSOLE STEERING GEAR STBD STEERING GEAR UNIT HEATER STEERING GEAR - PORT STERN ANCHOR COMPARTMENT EXHAUST FAN STERN ANCHOR WINCH STERN WINCH FLOODLIGHT STOREROOM UNIT HEATER SUZEX CANAL LIGHT RECEPT SUPPLY FAN - BOWTHRUSTER COMPARTMENT SUPPLY FAN - EMERGENCY GENERATOR ROOM SUPPLY FAN - GALLEY MAKE-UP SUPPLY FAN - TUNNEL	P106/12 P101/8 EP103/7 MAIN SWBD L105/5 L105/8 L105/2 L105/7 EMERG SWBD EMERG SWBD EMERG SWBD MAIN SWBD EL102/12 MAIN SWBD MAIN SWBD L104/18	WASTE COMPACTOR WC UNIT HEATERS WEATHERFAX RECEIVER WELDER WHEELHOUSE COFFEE MAKER WHEELHOUSE DRINKING FOUNTAIN WHEELHOUSE LIGHTING WHEELHOUSE RECPTS WHEELHOUSE dc PANEL (EPO24-1) WHEELHOUSE ELECTRONICS PANEL (EP103) WHEELHOUSE EMERGENCY LIGHTING PANEL (EL 102) WHEELHOUSE LIGHTING PANEL (P105) WHISTLE AND FOGHORN WINCH - BOW RAMP WINCH - STERN ANCHOR WORKSHOP BENCH GRINDER
P204/6 EP103/6	OIL WATER SEPARATOR OMEGA RCVR R2163 SRN 23	EMERG SWBD EP103/13 EP103/15 EP103/10 P202/1 EP103/2 EP103/9 L104/15 L104/12 L104/9 L104/9	RADAR DISTRIBUTION POWER PANEL RADAR S BAND XMTR RCVR RADAR X BAND XMTR RCVR RADIO TELEPHONE ALARM GENERATOR RANGE RCVR ADF 4005A RCVR XMTR RT 1277 URC 92 RECEPTACLE - LAUNDRY IRON RECEPTACLE - SICKBAY REFRIGERATOR RECEPTACLES - 01 LEVEL (PORT) RECEPTACLES - 01 LEVEL (PORT) AND CHIEF ENGINEER'S REFRIGERATOR	EP103/13 AUX MACH MC EL102/4 EL102/5 EP103/11 P204/2 EPO24/B-14 EPO24/B-13 EL102/11 MAIN SWBD MAIN SWBD EL102/10 P106/3 EL102/17 EP103/12 AUX MACH MCC AUX MACH MCC EPO24/B-9 EPO24/B-8 EMERG SWBD FWD DK MACH MCC L105/6 ENG RM VENT MCC ENG RM VENT MCC P203/2 EPO24/B-11 AUX MACH MCC EPO24/B-13 EPO24/B-8 EMERG SWBD AUX MACH MCC	S BAND XMTR RCVR SEA WATER COOLING PUMP SEARCHLIGHT, 500 WATT ZENON (PORT) SEARCHLIGHT, 500 WATT ZENON (STBD) SECURE COMMUNICATIONS PANEL SEWAGE TREATMENT PLANT SHAFT TACHOMETER (PORT) SHAFT TACHOMETER (STBD) SHIP'S CONTROL CONSOLE SHORE POWER TRANSFORMERS - 240V SHORE POWER TRANSFORMERS - 480V SIGNAL LAMPS, ALDIS SLICER SPEED LOG SPT AUD VIS DEVICES SSDG JACKET WATER HEATER NO. 1 (STBD) SSDG JACKET WATER HEATER NO. 2 (PORT) SSDG NO. 2 SSDG NO. 1 SSDG-2 BATTERY CHARGER STBD BOW ANCHOR WINDLASS STBD CARGO FLOODLIGHT STBD ENGINE ROOM EXHAUST FAN STBD ENGINE ROOM SUPPLY FAN STBD ENGINE ROOM UNIT HEATER STBD MAIN ENGINE STBD MAIN ENGINE JACKET WATER HEATER NO. 1 STBD SHAFT TACHOMETER STBD SSDG STBD SSDG BATTERY CHARGER STBD SSDG JACKET WATER HEATER NO. 1	L102/12 L102/12 P106/13 P106/11 P211/8 P106/12 P211/2 P201/5 P201/1	TANK LEVEL INDICATORS TLI TOASTER - GALLEY TOASTER - MESS DECK TOILET EXHAUST FAN TRASH COMPACTOR TUNNEL SUPPLY FAN TUNNEL UNIT HEATER AFT TUNNEL UNIT HEATER FORWARD	EP103/15	X BAND XMTR RCVR
P211/4 P201/2 EPO24-1B	PAINT LOCKER EXHAUST FAN PAINT LOCKER UNIT HEATER PILOTHOUSE BOWTHRUSTER CONTROL UNIT INDICATOR LIGHT ILLUMINATION	L104/7 L104/7 L104/17 L102/5 L102/5 L102/4 L104/8 L104/7 L104/7 L104/7 L104/7 L104/7 L104/3 L102/4 L102/4	RECEPTACLES - GALLEY RECEPTACLES - GALLEY, MESS DECK, AND PROVISIONS STOREROOM RECEPTACLES - MAIN DECK AND ABOVE (WEATHER) RECEPTACLES - MAIN DECK FORWARD AND BELOW DECK (STBD) RECEPTACLES - MAIN DECK FWD RECEPTACLES - MAIN DECK (FORWARD) RECEPTACLES - MASTER'S REFRIGERATOR RECEPTACLES - MESS DECK RECEPTACLES - PROVISIONS STOREROOM RECEPTACLES - RECREATION ROOM RECEPTACLES - STEERING GEAR ROOM RECEPTACLES - STEERING GEAR ROOM, MAIN DECK FORWARD, AND BELOW MAIN DECK (PORT)	EP103/12 AUX MACH MCC AUX MACH MCC EPO24/B-9 EPO24/B-8 EMERG SWBD FWD DK MACH MCC L105/6 ENG RM VENT MCC ENG RM VENT MCC P203/2 EPO24/B-11 AUX MACH MCC EPO24/B-13 EPO24/B-8 EMERG SWBD AUX MACH MCC	RECEPTACLES - WORKSHOP RECEPTACLES - EMERGENCY GENERATOR ROOM (STBD) RECEPTACLES - WHEEL HOUSE REDUCTION GEAR COOLING WATER PUMP NO. 1 REDUCTION GEAR COOLING WATER PUMP NO. 2 REFRIGERATOR - 20 CUBIC FOOT REFRIGERATOR - 30 CUBIC FOOT REFRIGERATOR - CHIEF ENGINEER'S REFRIGERATOR - MASTER'S REFRIGERATOR - MESS DECK REFRIGERATOR - SICKBAY ROTARY WINDOW WIPERS RPX 150 BATTERY CHARGER	P201/3 P201/4 P203/5 P203/3 P203/2 P203/1 P201/2 P201/2 P203/4 P203/6 P201/5 P201/1 P101/3 P101/8 EMERG SWBD	UNIT HEATER - BOATSWAIN STOREROOM UNIT HEATER - BOWTHRUSTER COMPARTMENT UNIT HEATER - EMERGENCY GENERATOR ROOM UNIT HEATER - ENGINE ROOM (PORT) UNIT HEATER - ENGINE ROOM (STBD) UNIT HEATER - MACHINE SHOP UNIT HEATER - PAINT LOCKER UNIT HEATER - STEERING GEAR COMPARTMENT UNIT HEATER - STOREROOM UNIT HEATER - TUNNEL AFT UNIT HEATER - TUNNEL FORWARD UNIT HEATERS - CREW HEAD UNIT HEATERS - HEAD URC-80/6100 RADIO BATTERY CHARGER	EL102/1	YARDARM BLINKERS
EL102/11 EMERG SWBD EMERG SWBD EMERG SWBD P203/8 MAIN SWBD FWD DK MACH MCC L105/3 ENG RM VENT MCC ENG RM VENT MCC P203/3 EPO24/B-12	PILOTHOUSE CONTROL CONSOLE PILOTHOUSE dc PANEL (EPO24-1) PILOTHOUSE ELECTRONICS PANEL (EP103) PILOTHOUSE EMERGENCY LIGHTING PANEL (EL102) PILOTHOUSE HEATER PILOTHOUSE LIGHTING PANEL (P105) PORT BOW ANCHOR WINDLASS PORT CARGO FLOODLIGHT PORT ENGINE ROOM EXHAUST FAN PORT ENGINE ROOM SUPPLY FAN PORT ENGINE ROOM UNIT HEATER PORT MAIN ENGINE	L104/8 L104/8 L102/4 L102/5 L104/9 L104/3	RECEPTACLES - 01 LEVEL (STBD) RECEPTACLES - 01 LEVEL (STBD) AND MASTER'S REFRIGERATOR RECEPTACLES - BELOW MAIN DECK (PORT) RECEPTACLES - BELOW MAIN DECK (STBD) RECEPTACLES - CHIEF ENGINEER'S REFRIGERATOR RECEPTACLES - EMERGENCY GENERATOR ROOM (STBD), PASSAGEWAY, AND RECREATION ROOM	P106/3 EL102/17 EP103/12 AUX MACH MCC AUX MACH MCC EPO24/B-9 EPO24/B-8 EMERG SWBD FWD DK MACH MCC L105/6 ENG RM VENT MCC ENG RM VENT MCC P203/2 EPO24/B-11 AUX MACH MCC EPO24/B-13 EPO24/B-8 EMERG SWBD AUX MACH MCC	RECEPTACLES - WORKSHOP RECEPTACLES - EMERGENCY GENERATOR ROOM (STBD) RECEPTACLES - WHEEL HOUSE REDUCTION GEAR COOLING WATER PUMP NO. 1 REDUCTION GEAR COOLING WATER PUMP NO. 2 REFRIGERATOR - 20 CUBIC FOOT REFRIGERATOR - 30 CUBIC FOOT REFRIGERATOR - CHIEF ENGINEER'S REFRIGERATOR - MASTER'S REFRIGERATOR - MESS DECK REFRIGERATOR - SICKBAY ROTARY WINDOW WIPERS RPX 150 BATTERY CHARGER	P201/3 P201/4 P203/5 P203/3 P203/2 P203/1 P201/2 P201/2 P203/4 P203/6 P201/5 P201/1 P101/3 P101/8 EMERG SWBD	UNIT HEATER - BOATSWAIN STOREROOM UNIT HEATER - BOWTHRUSTER COMPARTMENT UNIT HEATER - EMERGENCY GENERATOR ROOM UNIT HEATER - ENGINE ROOM (PORT) UNIT HEATER - ENGINE ROOM (STBD) UNIT HEATER - MACHINE SHOP UNIT HEATER - PAINT LOCKER UNIT HEATER - STEERING GEAR COMPARTMENT UNIT HEATER - STOREROOM UNIT HEATER - TUNNEL AFT UNIT HEATER - TUNNEL FORWARD UNIT HEATERS - CREW HEAD UNIT HEATERS - HEAD URC-80/6100 RADIO BATTERY CHARGER		
	- O -		- Q -		- R -		- S -		- T -
	- P -		- Q -		- R -		- S -		- T -
	- O -		- Q -		- R -		- S -		- T -
	- P -		- Q -		- R -		- S -		- T -
	- O -		- Q -		- R -		- S -		- T -
	- P -		- Q -		- R -		- S -		- T -
	- O -		- Q -		- R -		- S -		- T -
	- P -		- Q -		- R -		- S -		- T -
	- O -		- Q -		- R -		- S -		- T -
	- P -		- Q -		- R -		- S -		- T -
	- O -		- Q -		- R -		- S -		- T -
	- P -		- Q -		- R -		- S -		- T -
	- O -		- Q -		- R -		- S -		- T -
	- P -		- Q -		- R -		- S -		- T -
	- O -		- Q -		- R -		- S -		- T -
	- P -		- Q -		- R -		- S -		- T -
	- O -		- Q -		- R -		- S -		- T -
	- P -		- Q -		- R -		- S -		- T -
	- O -		- Q -		- R -		- S -		- T -
	- P -		- Q -		- R -		- S -		- T -
	- O -		- Q -		- R -		- S -		- T -
	- P -		- Q -		- R -		- S -		- T -
	- O -		- Q -		- R -		- S -		- T -
	- P -		- Q -		- R -		- S -		- T -
	- O -		- Q -		- R -		- S -		- T -
	- P -		- Q -		- R -		- S -		- T -
	- O -		- Q -		- R -		- S -		- T -
	- P -		- Q -		- R -		- S -		- T -
	- O -		- Q -		- R -		- S -		- T -
	- P -		- Q -		- R -		- S -		- T -
	- O -		- Q -		- R -		- S -		- T -
	- P -		- Q -		- R -		- S -		- T -
	- O -		- Q -		- R -		- S -		- T -
	- P -		- Q -		- R -		- S -		- T -
	- O -		- Q -		- R -		- S -		- T -
	- P -		- Q -		- R -		- S -		- T -
	- O -		- Q -		- R -		- S -		- T -
	- P -		- Q -		- R -		- S -		- T -
	- O -		- Q -		- R -		- S -		- T -
	- P -		- Q -		- R -		- S -		- T -
	- O -		- Q -		- R -		- S -		- T -
	- P -		- Q -		- R -		- S -		- T -
	- O -		- Q -		- R -		- S -		- T -
	- P -		- Q -		- R -		- S -		- T -
	- O -		- Q -		- R -		- S -		- T -
	- P -		- Q -		- R -		- S -		- T -
	- O -		- Q -		- R -		- S -		- T -
	- P -		- Q -		- R -		- S -		- T -
	- O -		- Q -		- R -		- S -		- T -
	- P -		- Q -		- R -		- S -		- T -
	- O -		- Q -		- R -		- S -		- T -
	- P -		- Q -		- R -		- S -		- T -
	- O -		- Q -		- R -		- S -		- T -
	- P -		- Q -		- R -		- S -		- T -
	- O -		- Q -		- R -		- S -		- T -
	- P -		- Q -		- R -		- S -		- T -
	- O -		- Q -		- R -		- S -		- T -
	- P -		- Q -		- R -		- S -		- T -
	- O -		- Q -		- R -		- S -		- T -
	- P -		- Q -		- R -		- S -		- T -
	- O -		- Q -		- R -		- S -		- T -
	- P -		- Q -		- R -		- S -		- T -
	- O -		- Q -		- R -		- S -		- T -
	- P -		- Q -		- R -		- S -		- T -
	- O -		- Q -		- R -		- S -		- T -
	- P -		- Q -		- R -		- S -		- T -
	- O -		- Q -		- R -		- S -		- T -
	- P -		- Q -		- R -		- S -		- T -
	- O -		- Q -		- R -		- S -		- T -
	- P -		- Q -		- R -		- S -		- T -
	- O -		- Q -		- R -		- S -		- T -

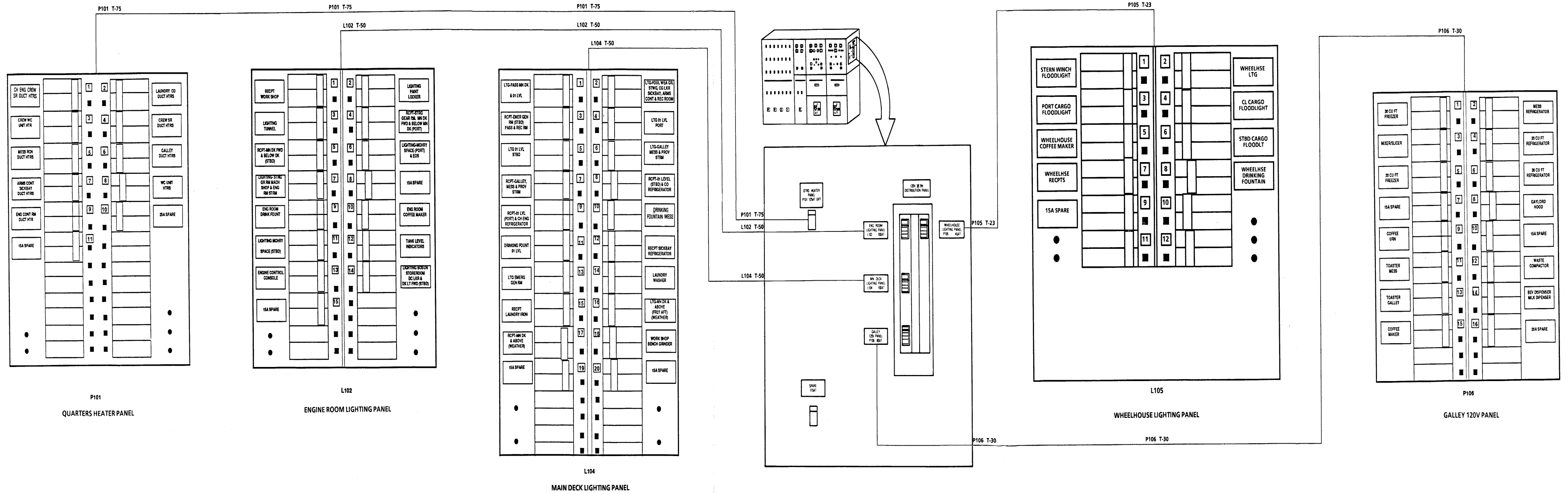

FO-1. Power Distribution (Sheet 4 of 19)  
FP-7/(FP-8 blank)

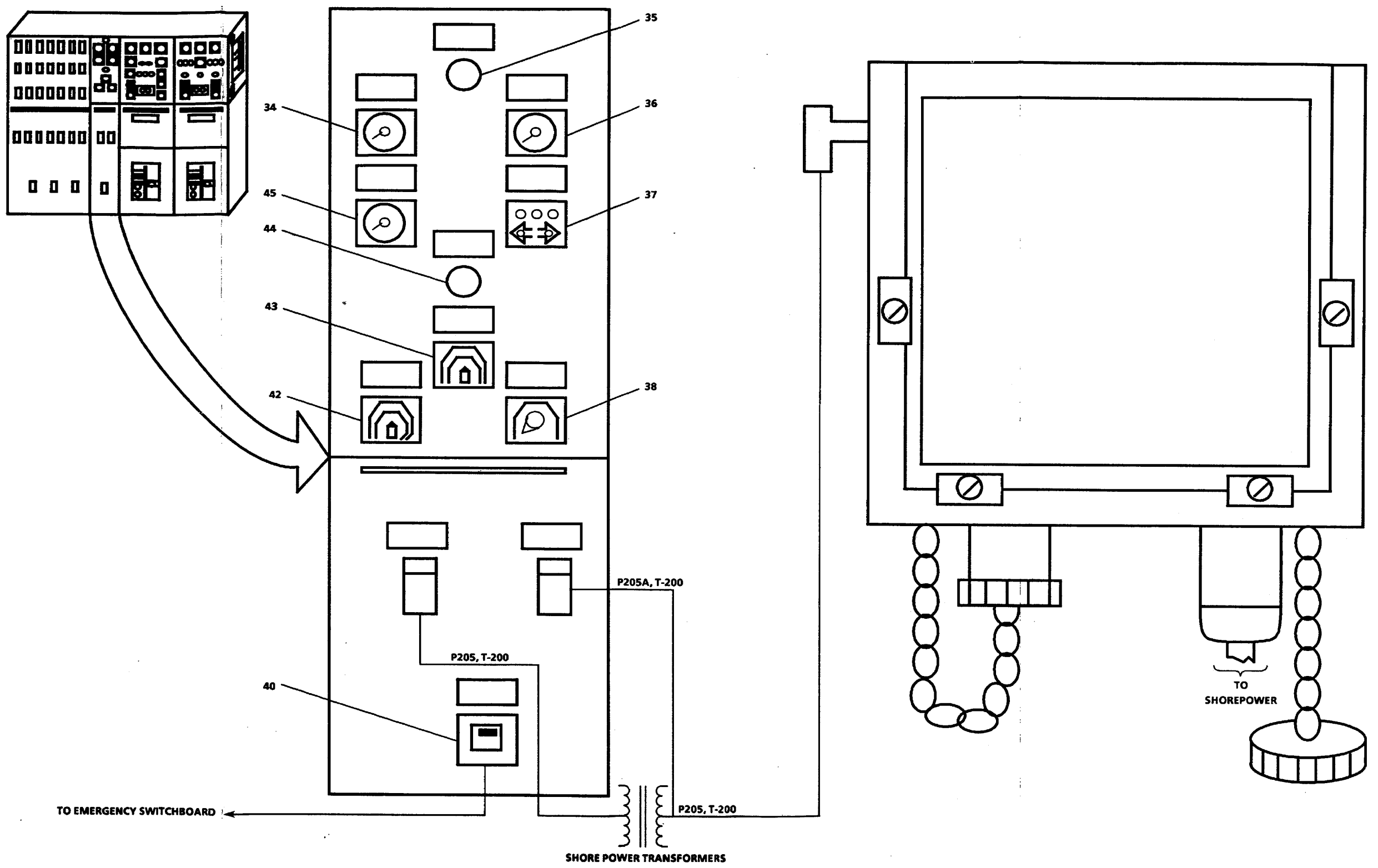

FO-1. Power Distribution (Sheet 5 of 19)  
FP-9/(FP-10 blank)

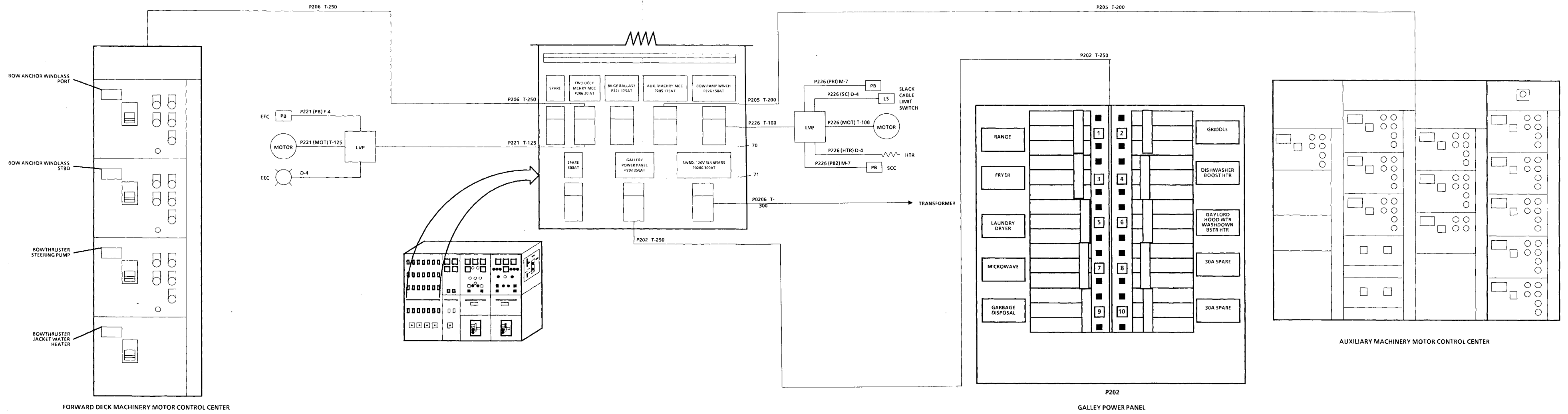

FO-1. Power Distribution (Sheet 6 of 19)  
FP-11/(FP-12 blank)

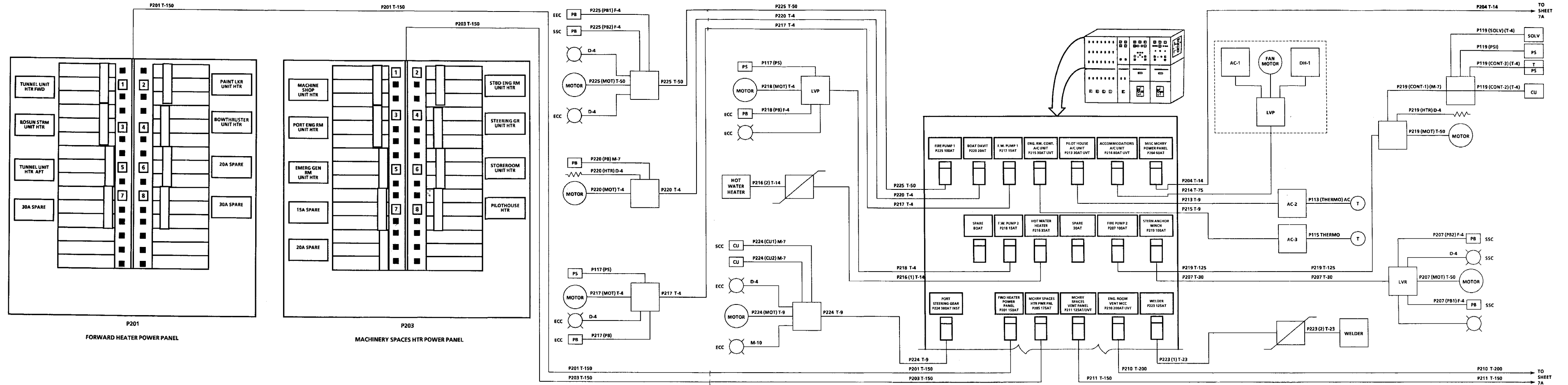

FO-1. Power Distribution (Sheet 7 of 19)  
FP-13/(FP-14 blank)

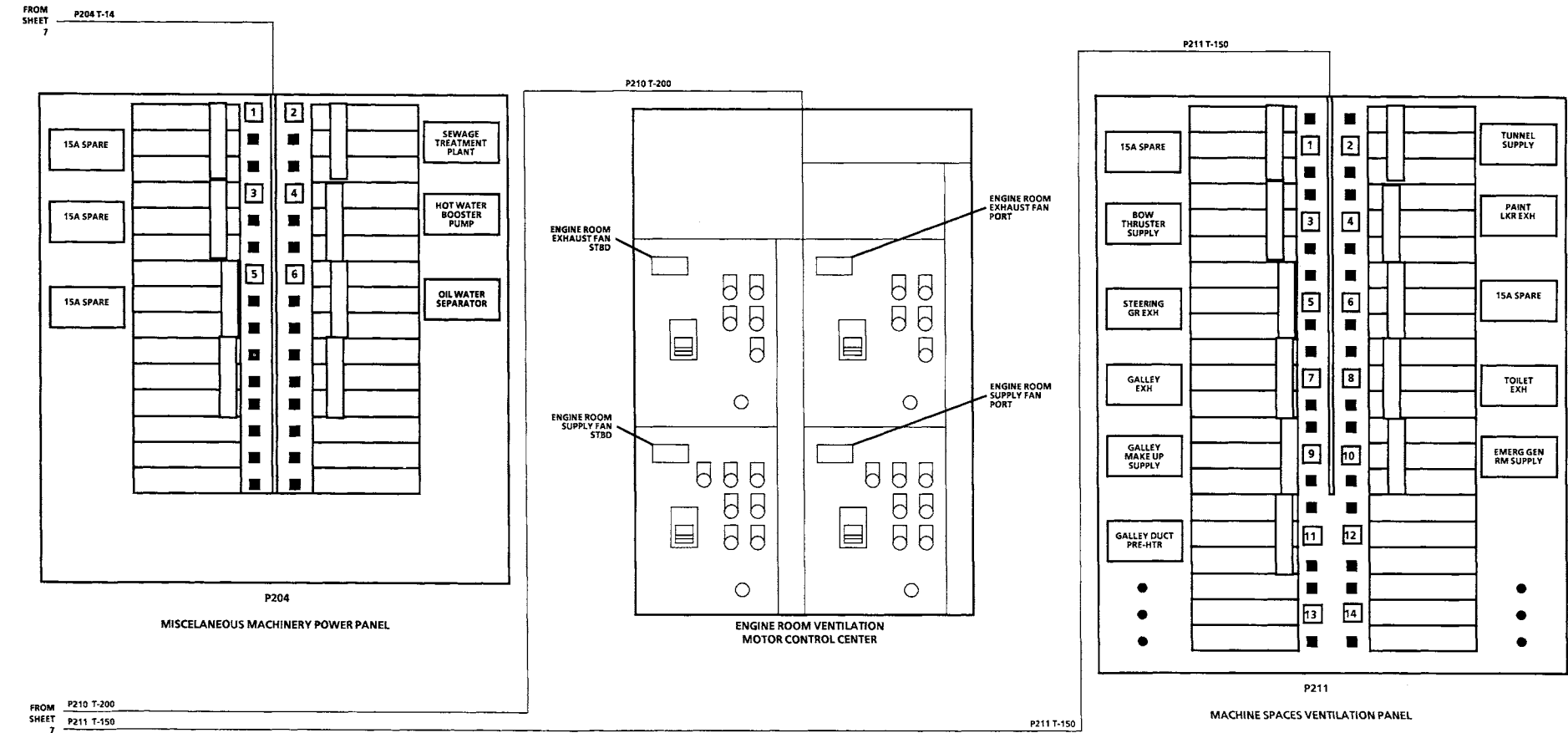

FO-1. Power Distribution (Sheet 7 of 19)  
FP-15/(FP-16 blank)

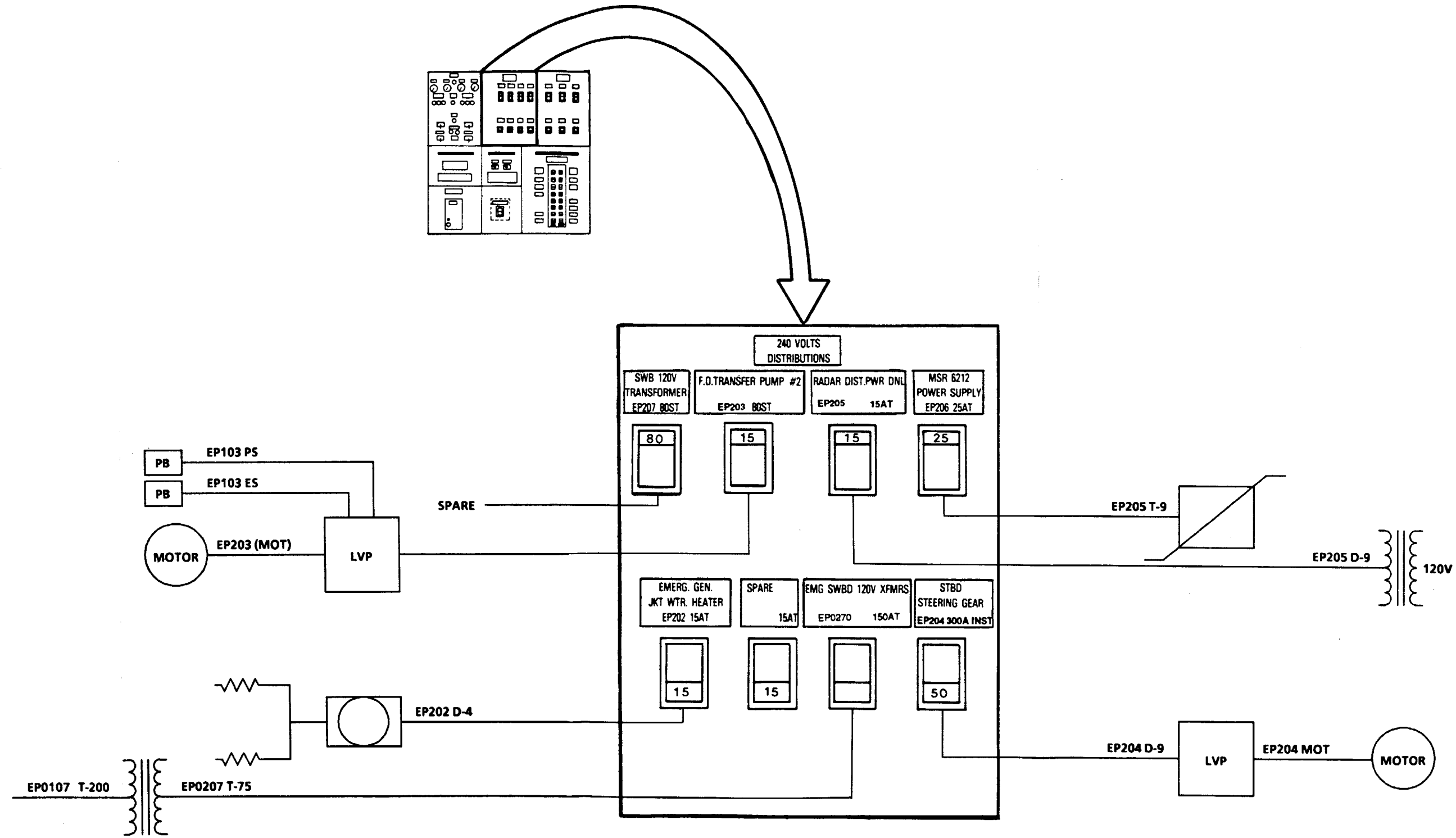

FO-1. Power Distribution (Sheet 8 of 19)  
FP-17/(FP-18 blank)



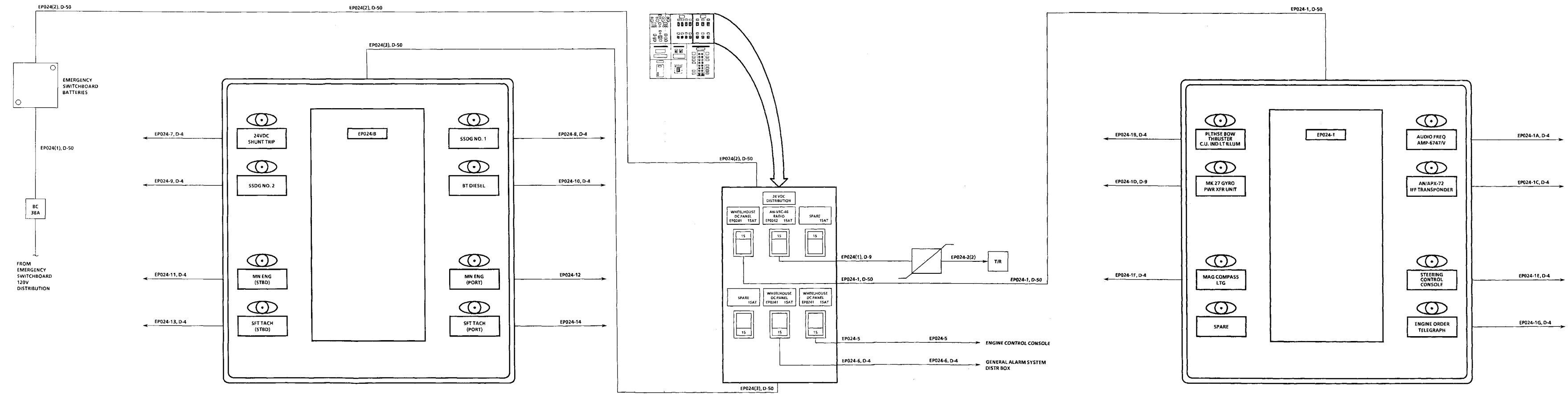

FO-1. Power Distribution (Sheet 9 of 19)  
 FP-19/(FP-20 blank)

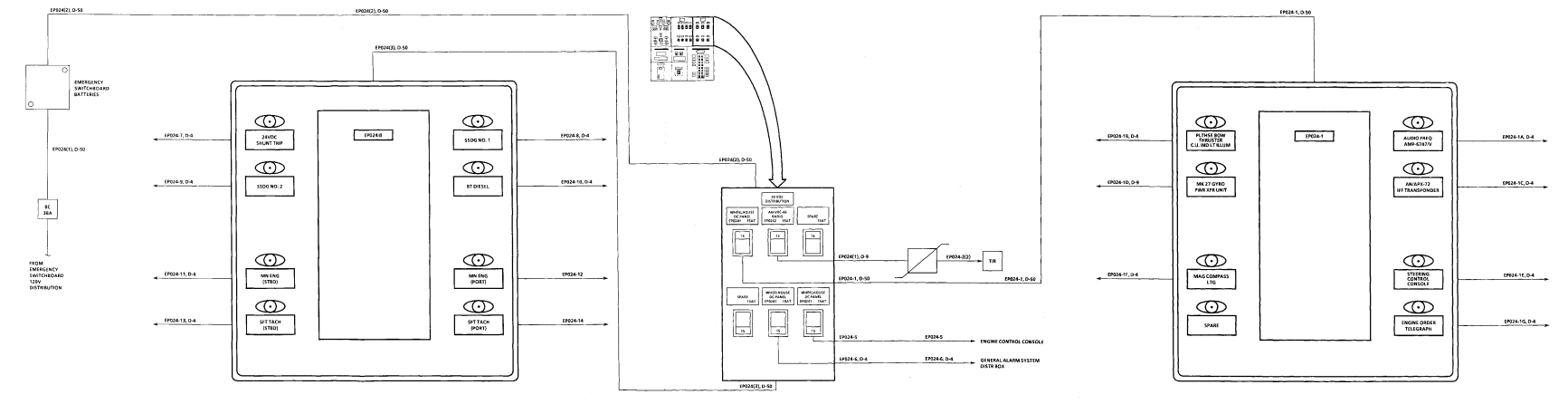

FO-1. Power Distribution (Sheet 1 of 19)  
FP-21/(FP-22 blank)

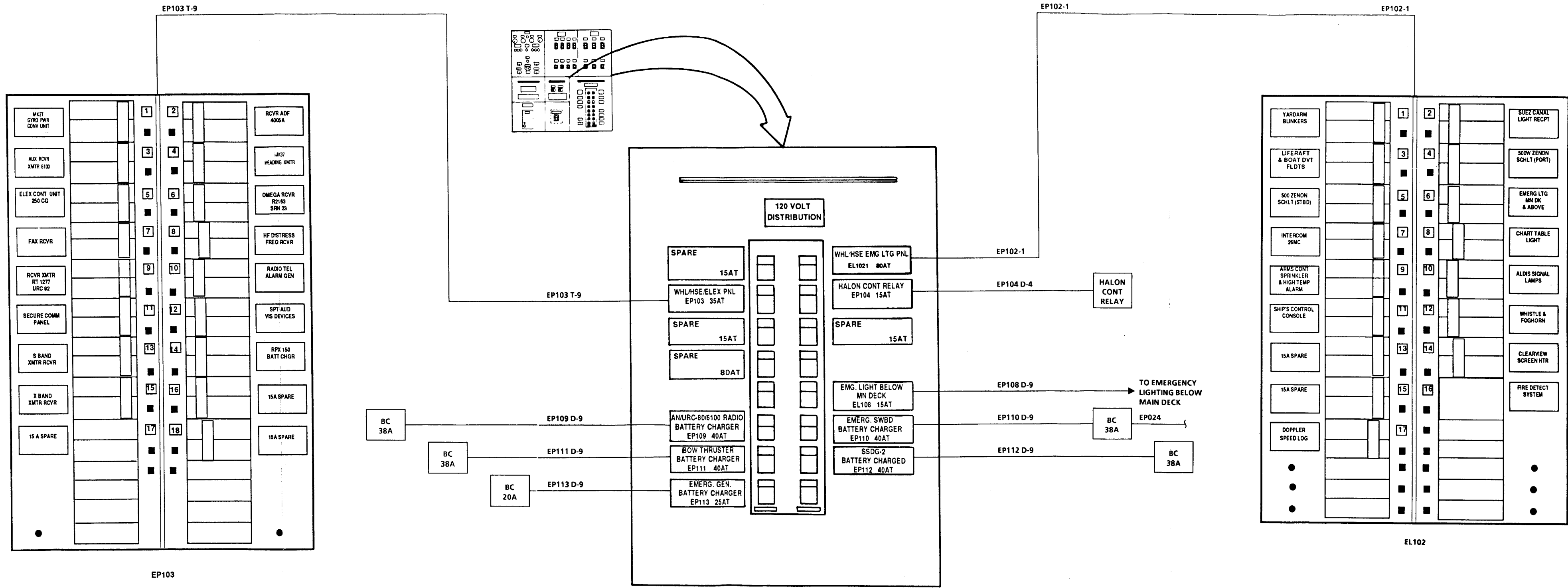

WHEELHOUSE ELECTRONICS PANEL

WHEELHOUSE EMERGENCY LIGHTING PANEL

FO-1. Power Distribution (Sheet 10 of 19)  
FP-21/(FP-22 blank)

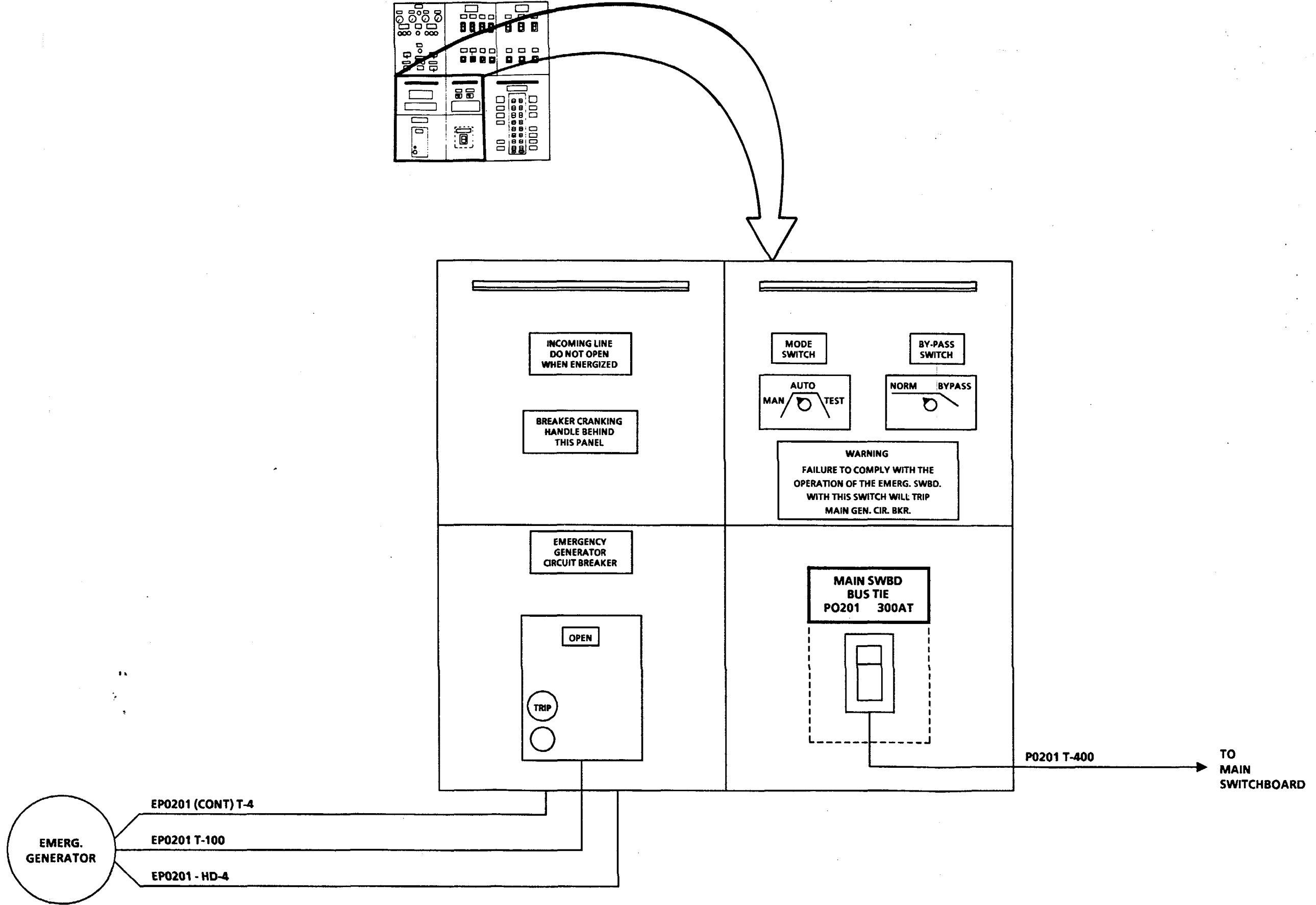

FO-1. Power Distribution (Sheet 11 of 19)  
FP-23/(FP-24 blank)

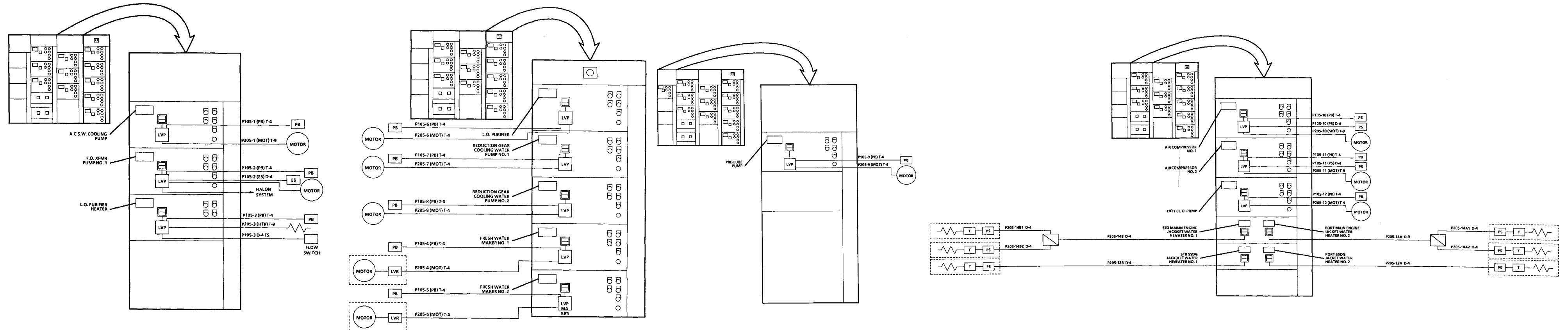

FO-1. Power Distribution (Sheet 12 of 19)  
FP-25/(FP-26 blank)

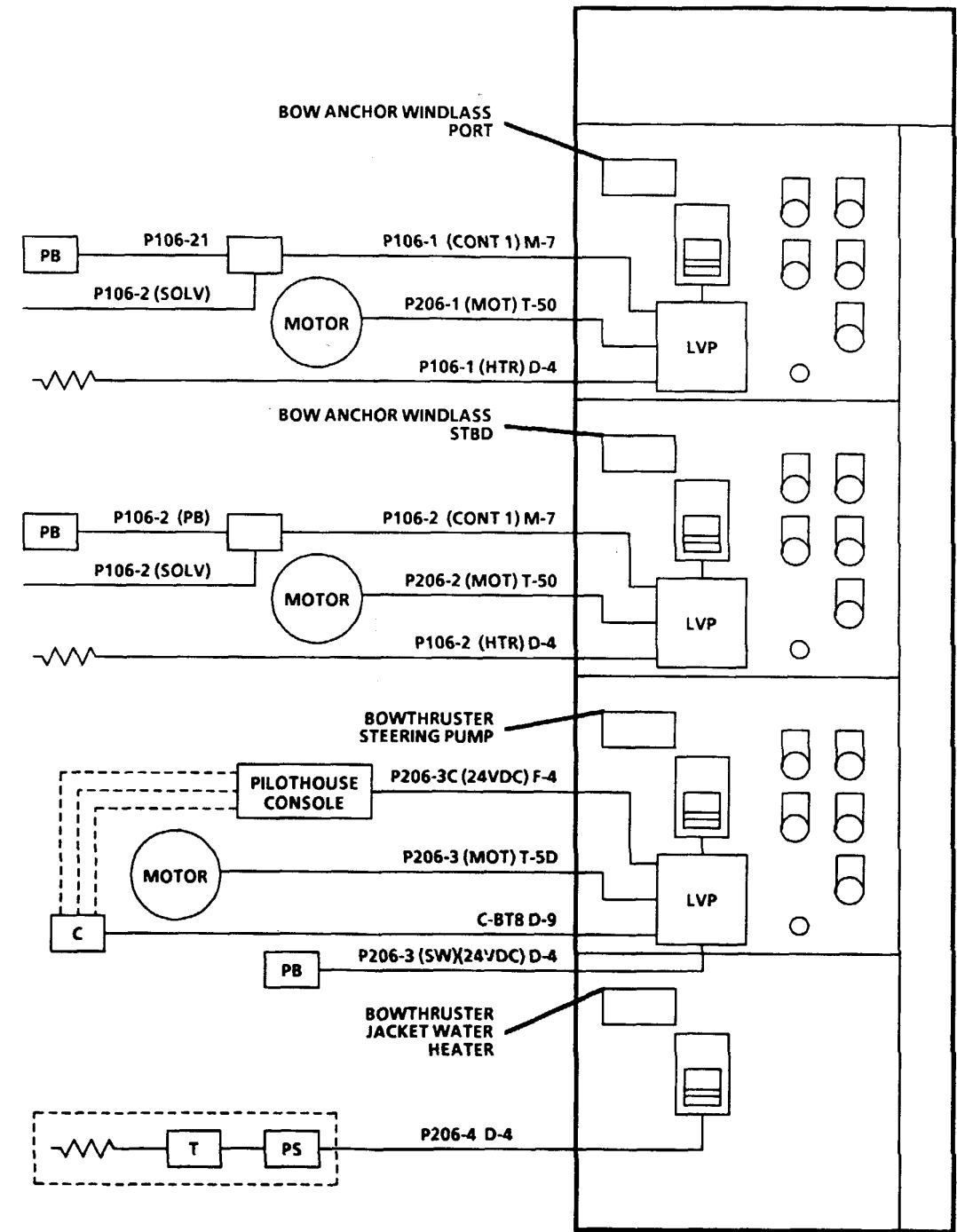
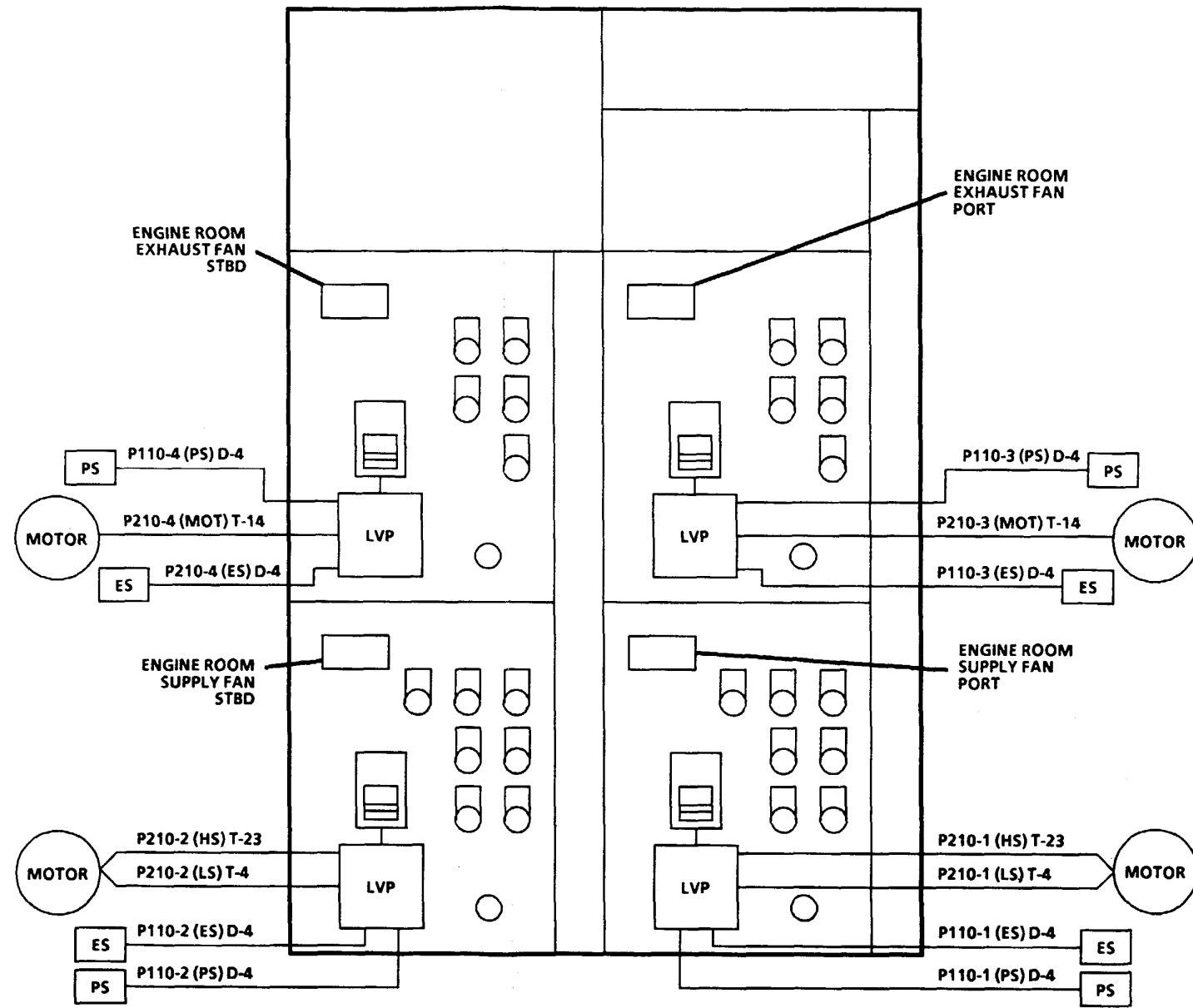

FO-1. Power Distribution (Sheet 13 of 19)  
FP-27/(FP-28 blank)

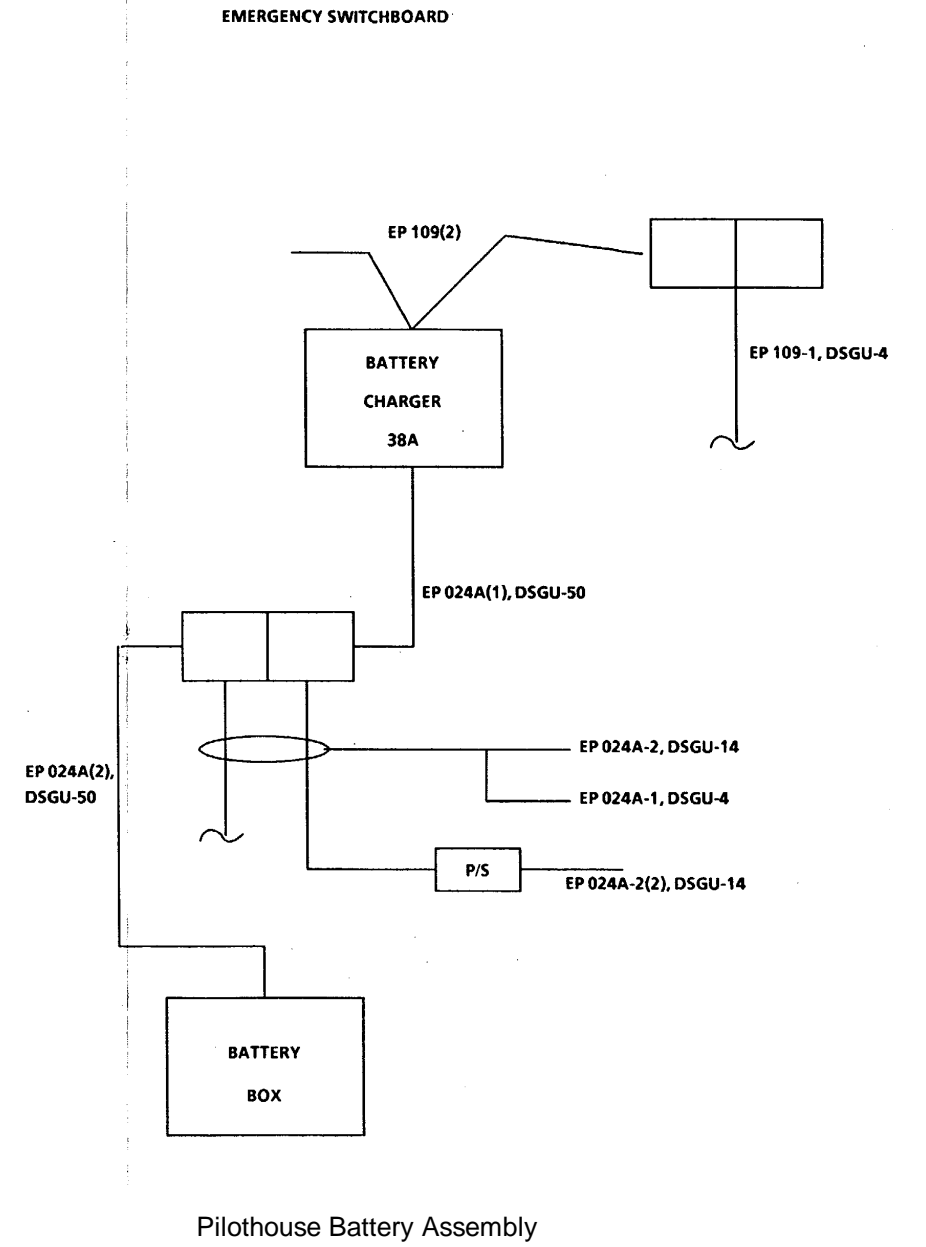
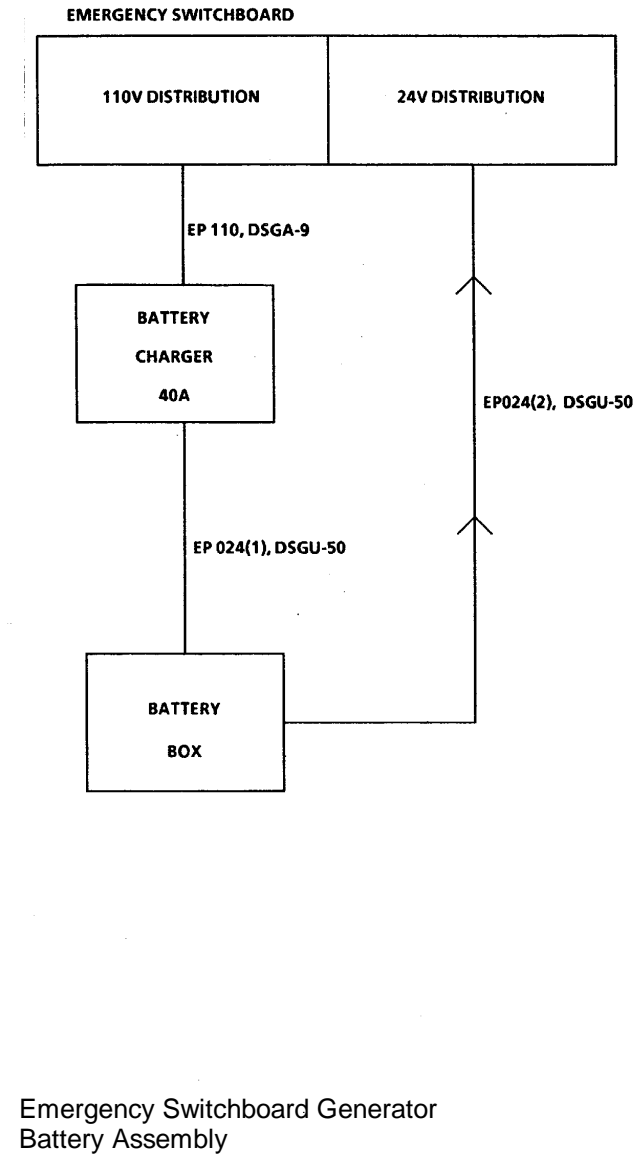
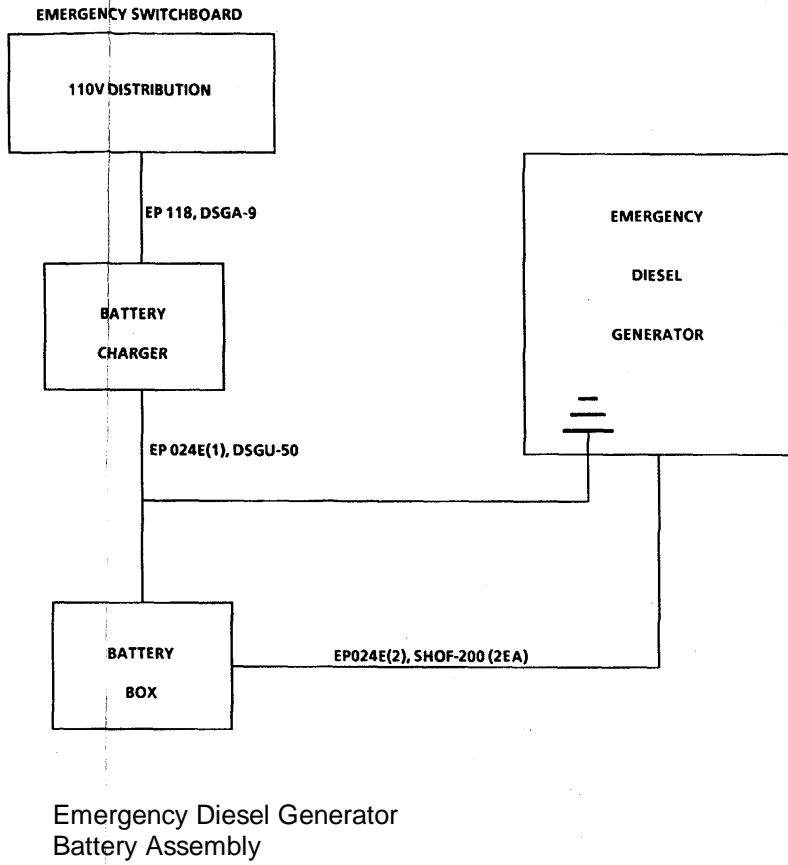
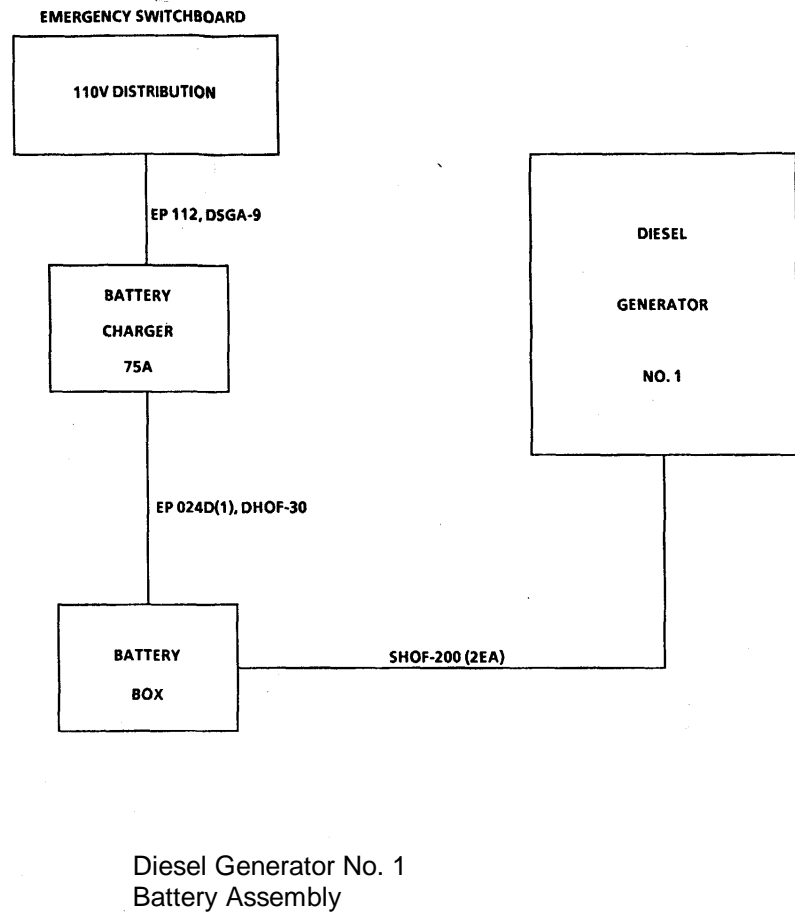
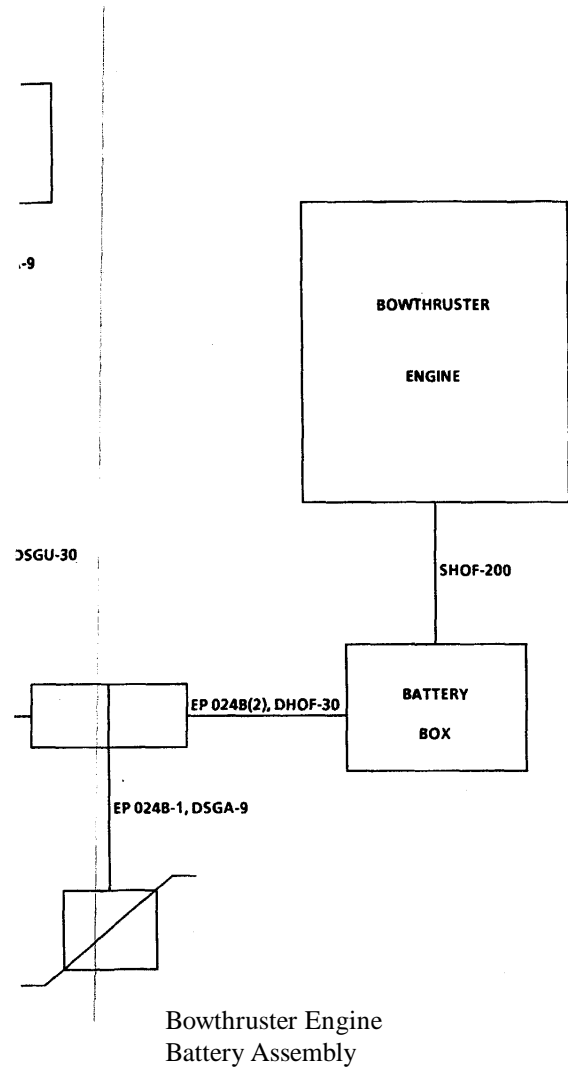

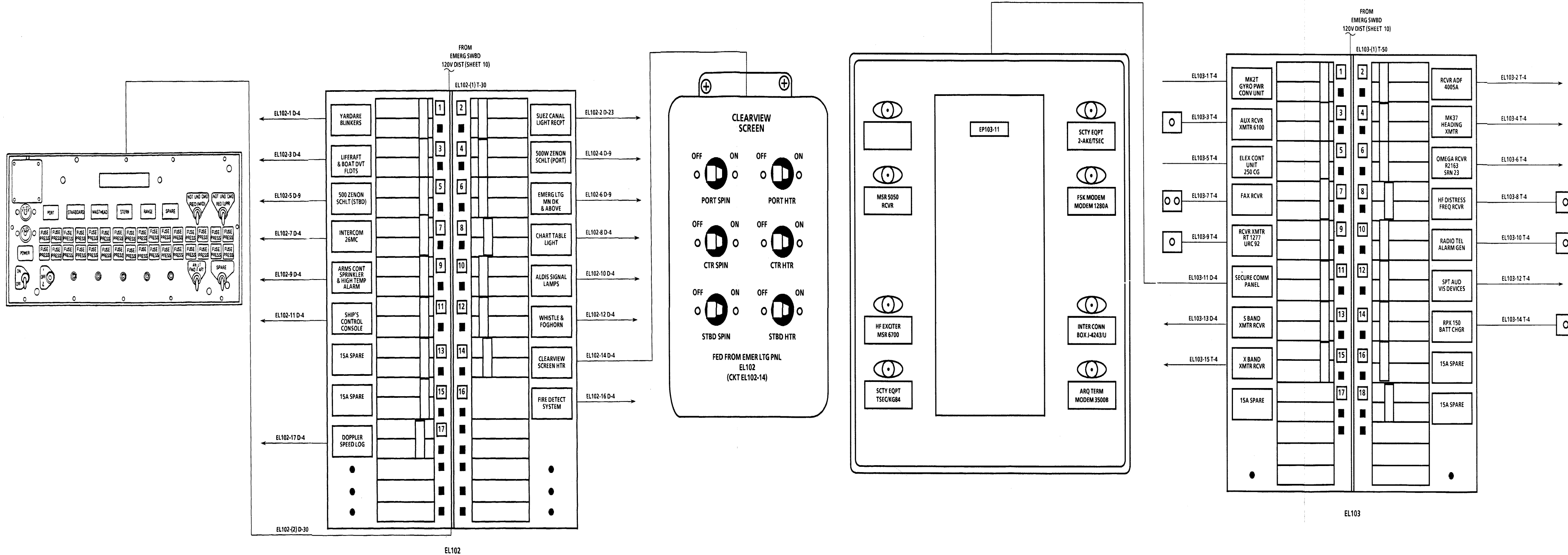

FO-1. Power Distribution (Sheet 15 of 19)

FP-31/(FP-32 blank)



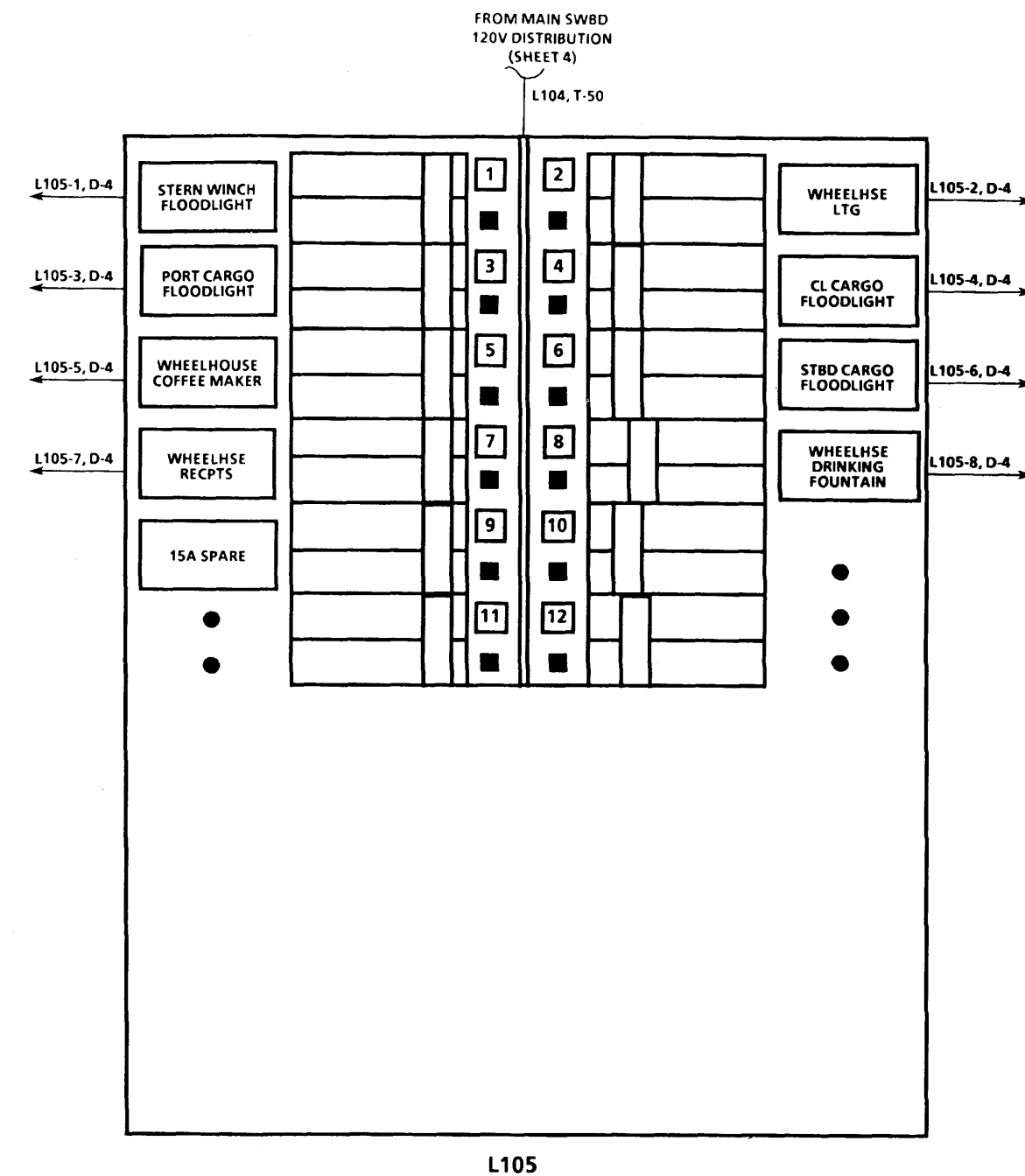
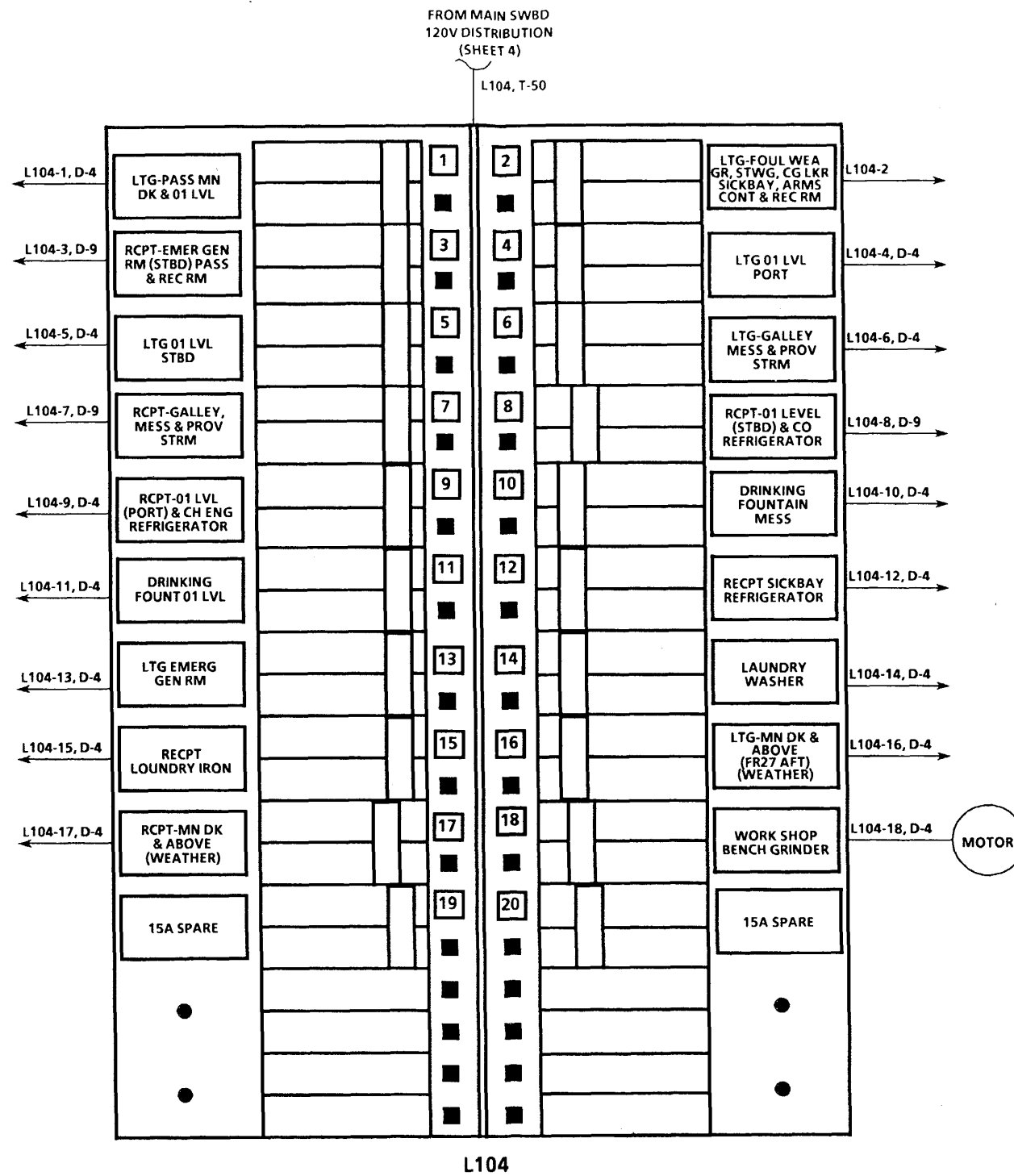
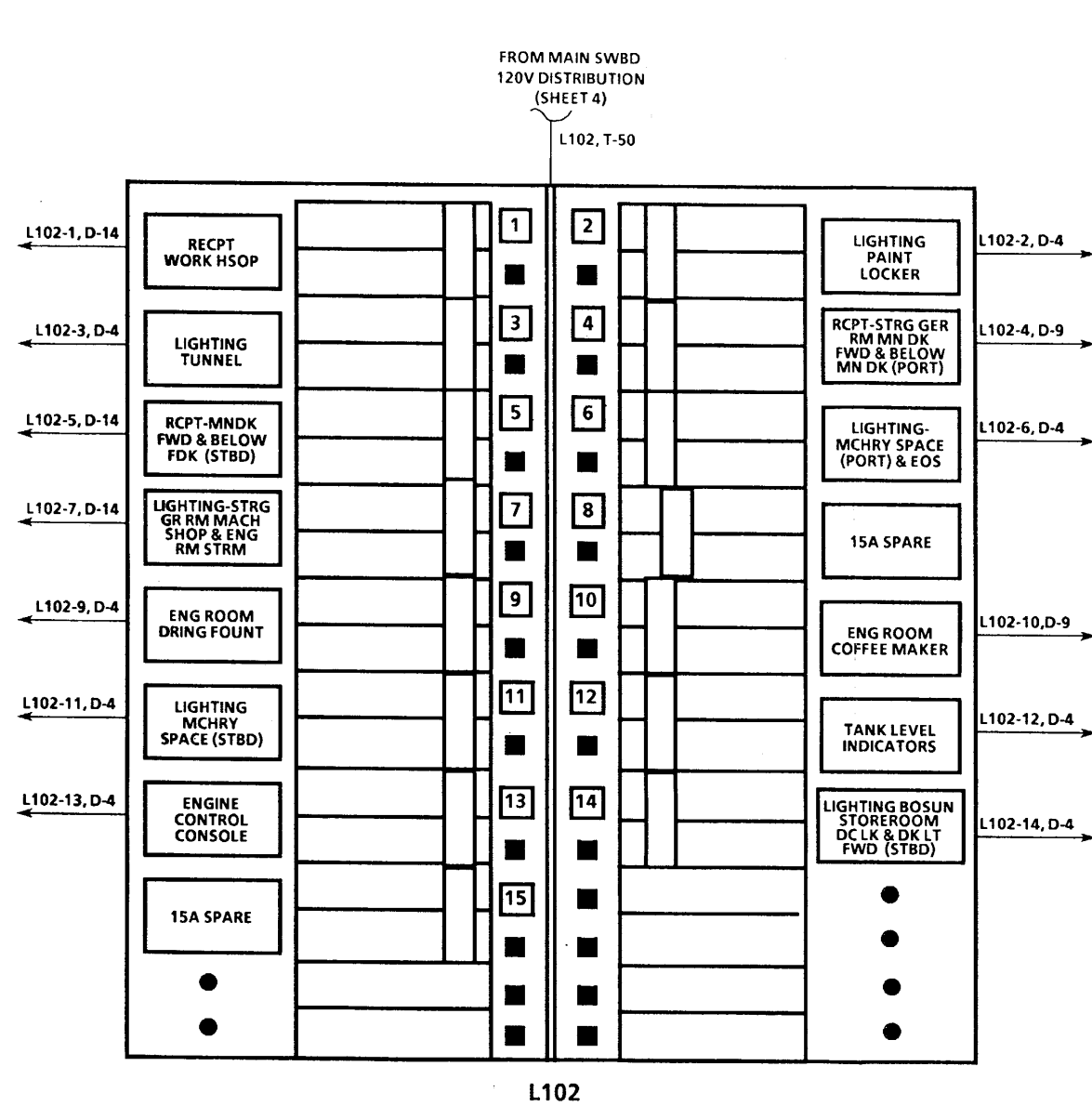

FO-1. Power Distribution (Sheet 16 of 19)

FP-33/(FP-34 blank)

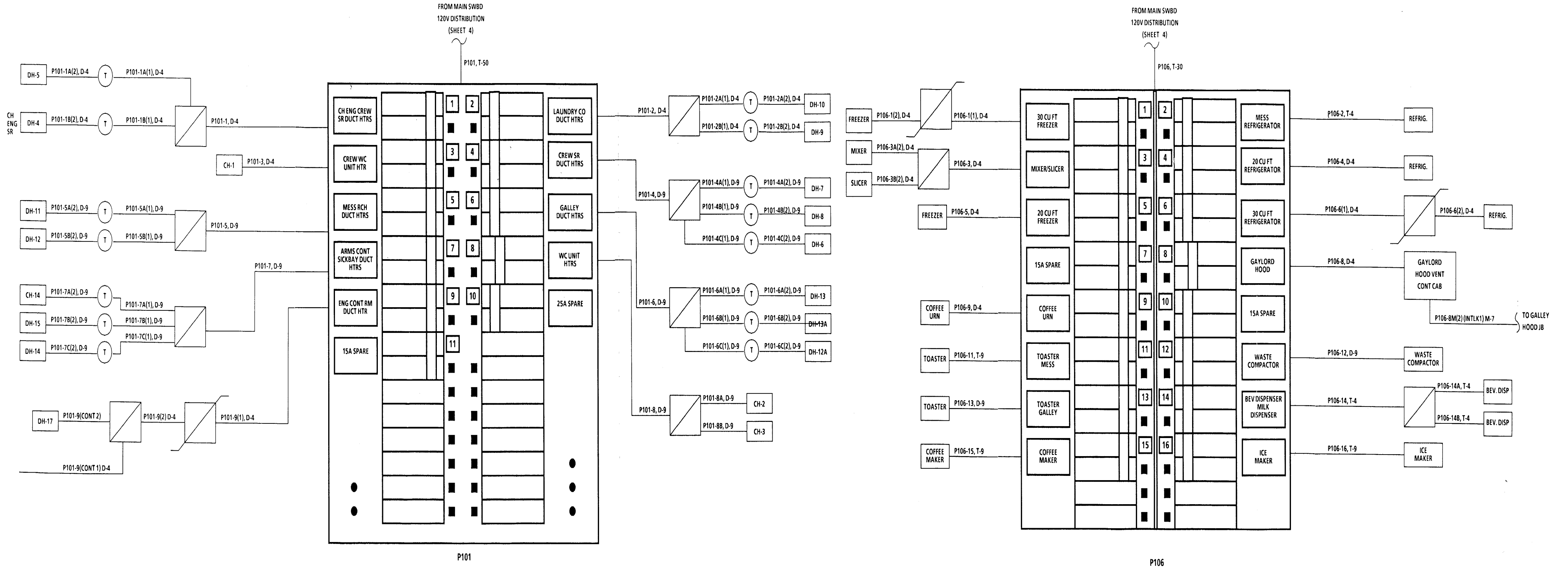

FO-1. Power Distribution (Sheet 17 of 19)

FP-35/(FP-36 blank)

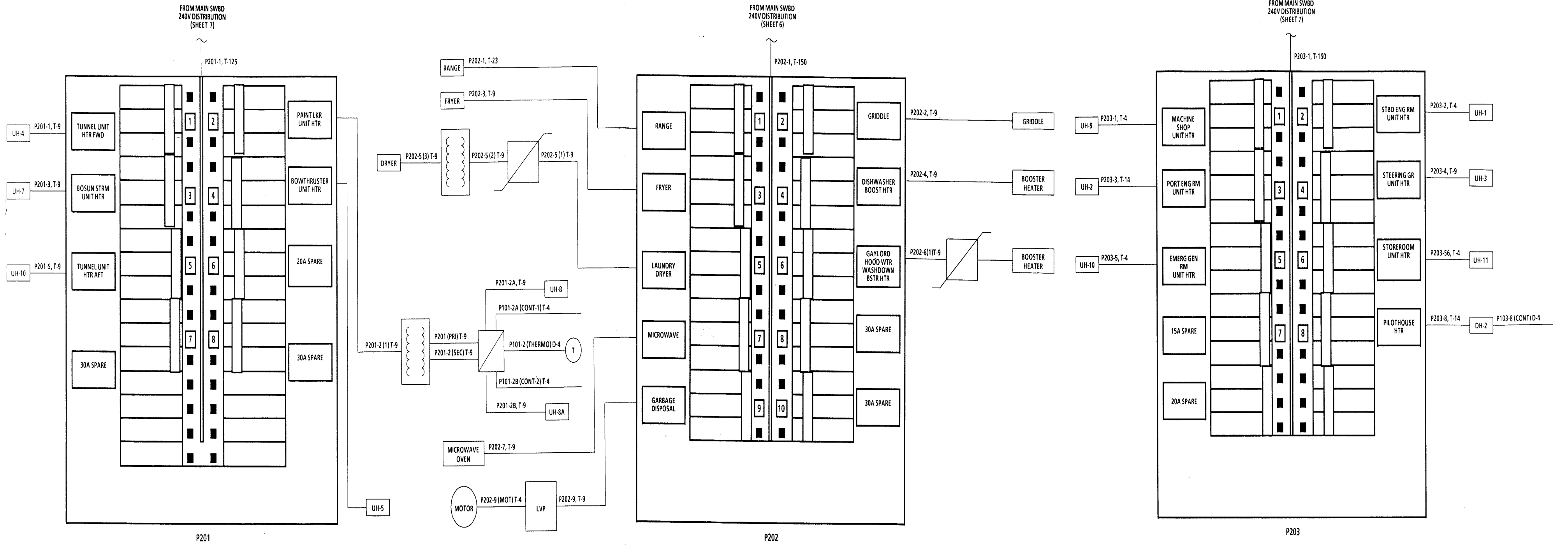

FO-1. Power Distribution (Sheet 18 of 19)  
FP-37/(FP-38 blank)

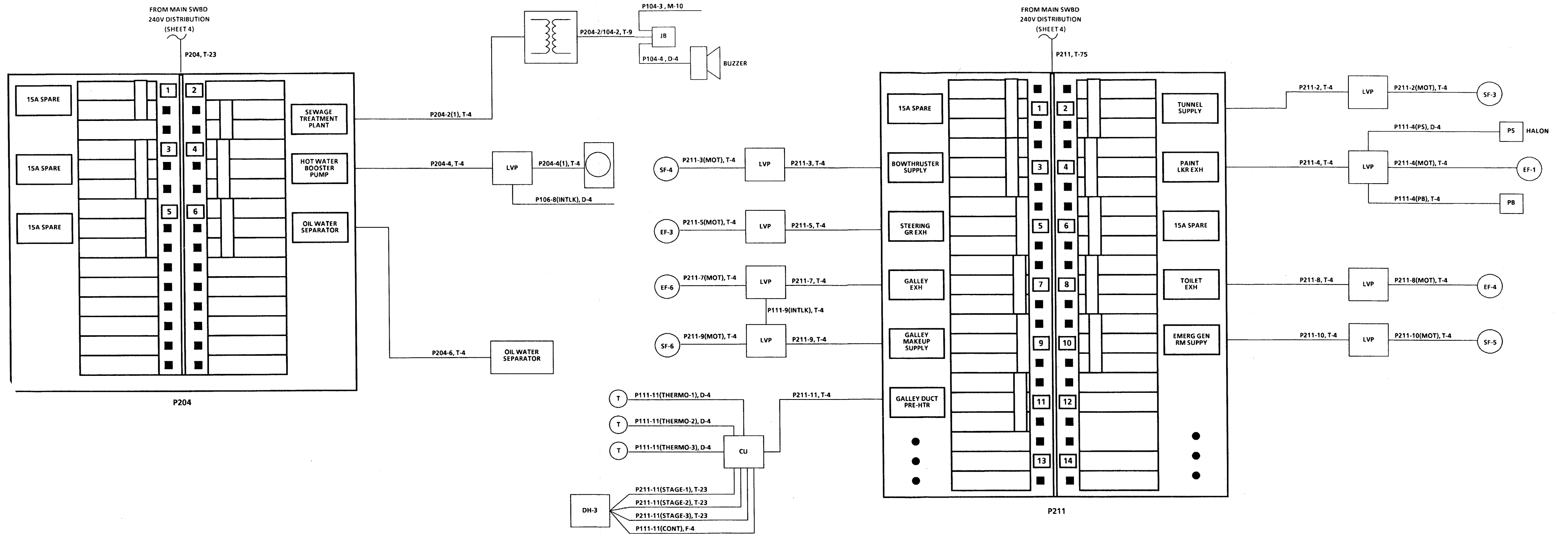

FO-1. Power Distribution (Sheet 19 of 19)

FP-39/(FP-40 blank)

By Order of the Secretary of the Army:

**CARL E. VUONO**  
General, United States Army  
Chief of Staff

Official:

**WILLIAM J. MEEHAN, II**  
Brigadier General, United States Army  
The Adjutant General

**DISTRIBUTION:**

To be distributed in accordance with DA FORM 12-25a, Unit and Direct Support and General Support Maintenance requirements for Landing Craft, Utility, LUC-1466, Type III.

U.S. GOVERNMENT PRINTING OFFICE: 1994 - 300-421 (02073)

These are the instructions for sending an electronic 2028

The following format must be used if submitting an electronic 2028. The subject line must be exactly the same and all fields must be included; however only the following fields are mandatory: 1, 3, 4, 5, 6, 7, 8, 9, 10, 13, 15, 16, 17, and 27.

From: "Whomever" <whomever@avma27.army.mil>  
To: TACOM-TECH-PUBS@ria.army.mil

Subject: DA Form 2028  
1. From: Joe Smith  
2. Unit: home  
3. Address: 4300 Park  
4. City: Hometown  
5. St: MO  
6. Zip: 77777  
7. Date Sent: 19-OCT-93  
8. Pub no: 55-2840-249-23  
9. Pub Title: TM  
10. Publication Date: 04-JUL-85  
11. Change Number: 7  
12. Submitter Rank: MSG  
13. Submitter FName: Joe  
14. Submitter MName: T  
15. Submitter LName: Smith  
16. Submitter Phone: 123-123-1234  
17. Problem: 1  
18. Page: 1  
19. Paragraph: 3  
20. Line: 4  
21. NSN: 5  
22. Reference: 6  
23. Figure: 7  
24. Table: 8  
25. Item: 9  
26. Total: 123  
27. Text:

This is the text for the problem below line 27.



<b>RECOMMENDED CHANGES TO PUBLICATIONS AND BLANK FORMS</b>  For use of this form, see AR 25-30; the proponent agency is OAASA	Use Part II ( <i>reverse</i> ) for Repair Parts and Special Tool Lists (RPSTL) and Supply Catalogs/Supply Manuals (SC/SM).	DATE
---	--	------

<b>TO:</b> ( <i>Forward to proponent of publication or form</i> ) ( <i>Include ZIP Code</i> )  <b>Technical Publication Information Office, TACOM. RI. Rock Island Arsenal. IL 61299-7630</b>	<b>FROM:</b> ( <i>Activity and location</i> ) ( <i>Include ZIP Code</i> )
---	---

**PART I - ALL PUBLICATIONS (EXCEPT RPSTL AND SC/SM) AND BLANK FORMS**

PUBLICATION/FORM NUMBER <b>TM 55-1905-223-24-18-2</b>	DATE <b>17 Jan 1989</b>	TITLE <b>Landing Craft , Utility (Basic Craft)</b>
--	----------------------------	---

ITEM	PAGE	PARA- GRAPH	LINE	FIGURE NO.	TABLE	RECOMMENDED CHANGES AND REASON

*\* Reference to line numbers within the paragraph or subparagraph.*

TYPED NAME, GRADE OR TITLE	TELEPHONE EXCHANGE/AUTOVON, PLUS EXTENSION	SIGNATURE
----------------------------	---	-----------



TO: <i>(Forward direct to addressee listed in publication)</i> <b>Technical Publication Information Office,  TACOM, RI, Rock Island Arsenal, IL  61299-7630</b>	FROM: <i>(Activity and location) (Include ZIP Code)</i>	DATE
--	---	------

**PART II - REPAIR PARTS AND SPECIAL TOOL LISTS AND SUPPLY CATALOGS/SUPPLY MANUALS**

PUBLICATION NUMBER <b>TM 55-1905-223-24-18-2</b>	DATE <b>17 Jan 1989</b>	TITLE <b>Landing Craft , Utility (Basic Craft)</b>
---	----------------------------	---

PAGE NO.	COLM NO.	LINE NO.	NATIONAL STOCK NUMBER	REFERENCE NO.	FIGURE NO.	ITEM NO.	TOTAL NO. OF MAJOR ITEMS SUPPORTED	RECOMMENDED ACTION

**PART III - REMARKS** *(Any general remarks or recommendations, or suggestions for improvement of publications and blank forms. Additional blank sheets may be used if more space is needed.)*

TYPED NAME, GRADE OR TITLE	TELEPHONE EXCHANGE/AUTOVON, PLUS EXTENSION	SIGNATURE
----------------------------	--	-----------

<b>RECOMMENDED CHANGES TO PUBLICATIONS AND BLANK FORMS</b>  For use of this form, see AR 25-30; the proponent agency is OAASA	Use Part II ( <i>reverse</i> ) for Repair Parts and Special Tool Lists (RPSTL) and Supply Catalogs/Supply Manuals (SC/SM).	DATE
---	--	------

<b>TO:</b> ( <i>Forward to proponent of publication or form</i> ) ( <i>Include ZIP Code</i> )  <b>Technical Publication Information Office, TACOM. RI. Rock Island Arsenal. IL 61299-7630</b>	<b>FROM:</b> ( <i>Activity and location</i> ) ( <i>Include ZIP Code</i> )
---	---

**PART I - ALL PUBLICATIONS (EXCEPT RPSTL AND SC/SM) AND BLANK FORMS**

<b>PUBLICATION/FORM NUMBER</b> <b>TM 55-1905-223-24-18-2</b>	<b>DATE</b> <b>17 Jan 1989</b>	<b>TITLE</b> <b>Landing Craft , Utility (Basic Craft)</b>
---	-----------------------------------	--

ITEM	PAGE	PARA- GRAPH	LINE	FIGURE NO.	TABLE	RECOMMENDED CHANGES AND REASON

*\* Reference to line numbers within the paragraph or subparagraph.*

TYPED NAME, GRADE OR TITLE	TELEPHONE EXCHANGE/AUTOVON, PLUS EXTENSION	SIGNATURE
----------------------------	---	-----------

TO: <i>(Forward direct to addressee listed in publication)</i> <b>Technical Publication Information Office, TACOM, RI, Rock Island Arsenal, IL 61299-7630</b>	FROM: <i>(Activity and location) (Include ZIP Code)</i>	DATE
--	---	------

**PART II - REPAIR PARTS AND SPECIAL TOOL LISTS AND SUPPLY CATALOGS/SUPPLY MANUALS**

PUBLICATION NUMBER <b>TM 55-1905-223-24-18-2</b>	DATE <b>17 Jan 1989</b>	TITLE <b>Landing Craft, Utility (Basic Craft)</b>
---	----------------------------	--

PAGE NO.	COLM NO.	LINE NO.	NATIONAL STOCK NUMBER	REFERENCE NO.	FIGURE NO.	ITEM NO.	TOTAL NO. OF MAJOR ITEMS SUPPORTED	RECOMMENDED ACTION

**PART III - REMARKS** *(Any general remarks or recommendations, or suggestions for improvement of publications and blank forms. Additional blank sheets may be used if more space is needed.)*

TYPED NAME, GRADE OR TITLE	TELEPHONE EXCHANGE/AUTOVON, PLUS EXTENSION	SIGNATURE
----------------------------	--	-----------



TO: <i>(Forward direct to addressee listed in publication)</i> <b>Technical Publication Information Office,  TACOM, RI, Rock Island Arsenal, IL  61299-7630</b>	FROM: <i>(Activity and location) (Include ZIP Code)</i>	DATE
--	---	------

**PART II - REPAIR PARTS AND SPECIAL TOOL LISTS AND SUPPLY CATALOGS/SUPPLY MANUALS**

PUBLICATION NUMBER <b>TM 55-1905-223-24-18-2</b>	DATE <b>17 Jan 1989</b>	TITLE <b>Landing Craft, Utility (Basic Craft)</b>
---	----------------------------	--

PAGE NO.	COLM NO.	LINE NO.	NATIONAL STOCK NUMBER	REFERENCE NO.	FIGURE NO.	ITEM NO.	TOTAL NO. OF MAJOR ITEMS SUPPORTED	RECOMMENDED ACTION

**PART III - REMARKS** *(Any general remarks or recommendations, or suggestions for improvement of publications and blank forms. Additional blank sheets may be used if more space is needed.)*

TYPED NAME, GRADE OR TITLE	TELEPHONE EXCHANGE/AUTOVON, PLUS EXTENSION	SIGNATURE
----------------------------	--	-----------

# The Metric System and Equivalents

## Linear Measure

1 centimeter = 10 millimeters = .39 inch  
 1 decimeter = 10 centimeters = 3.94 inches  
 1 meter = 10 decimeters = 39.37 inches  
 1 dekameter = 10 meters = 32.8 feet  
 1 hectometer = 10 dekameters = 328.08 feet  
 1 kilometer = 10 hectometers = 3,280.8 feet

## Weights

1 centigram = 10 milligrams = .15 grain  
 1 decigram = 10 centigrams = 1.54 grains  
 1 gram = 10 decigrams = .035 ounce  
 1 dekagram = 10 grams = .35 ounce  
 1 hectogram = 10 dekagrams = 3.52 ounces  
 1 kilogram = 10 hectograms = 2.2 pounds  
 1 quintal = 100 kilograms = 220.46 pounds  
 1 metric ton = 10 quintals = 1.1 short tons

## Liquid Measure

1 centiliter = 10 milliliters = .34 fl. ounce  
 1 deciliter = 10 centiliters = 3.38 fl. ounces  
 1 liter = 10 deciliters = 33.81 fl. ounces  
 1 dekaliter = 10 liters = 2.64 gallons  
 1 hectoliter = 10 dekaliters = 26.42 gallons  
 1 kiloliter = 10 hectoliters = 264.18 gallons

## Square Measure

1 sq. centimeter = 100 sq. millimeters = .155 sq. inch  
 1 sq. decimeter = 100 sq. centimeters = 15.5 sq. inches  
 1 sq. meter (centare) = 100 sq. decimeters = 10.76 sq. feet  
 1 sq. dekameter (are) = 100 sq. meters = 1,076.4 sq. feet  
 1 sq. hectometer (hectare) = 100 sq. dekameters = 2.47 acres  
 1 sq. kilometer = 100 sq. hectometers = .386 sq. mile

## Cubic Measure

1 cu. centimeter = 1000 cu. millimeters = .06 cu. inch  
 1 cu. decimeter = 1000 cu. centimeters = 61.02 cu. inches  
 1 cu. meter = 1000 cu. decimeters = 35.31 cu. feet

## Approximate Conversion Factors

To change	To	Multiply by	To change	To	Multiply by
inches	centimeters	2.540	ounce-inches	newton-meters	.007062
feet	meters	.305	centimeters	inches	.394
yards	meters	.914	meters	feet	3.280
miles	kilometers	1.609	meters	yards	1.094
square inches	square centimeters	6.451	kilometers	miles	.621
square feet	square meters	.093	square centimeters	square inches	.155
square yards	square meters	.836	square meters	square feet	10.764
square miles	square kilometers	2.590	square meters	square yards	1.196
acres	square hectometers	.405	square kilometers	square miles	.386
cubic feet	cubic meters	.028	square hectometers	acres	2.471
cubic yards	cubic meters	.765	cubic meters	cubic feet	35.315
fluid ounces	milliliters	29.573	cubic meters	cubic yards	1.308
pints	liters	.473	milliliters	fluid ounces	.034
quarts	liters	.946	liters	pints	2.113
gallons	liters	3.785	liters	quarts	1.057
ounces	grams	28.349	liters	gallons	.264
pounds	kilograms	.454	grams	ounces	.035
short tons	metric tons	.907	kilograms	pounds	2.205
pound-feet	newton-meters	1.356	metric tons	short tons	1.102
pound-inches	newton-meters	.11296			

## Temperature (Exact)

°F	Fahrenheit temperature	5/9 (after subtracting 32)	Celsius temperature	°C
----	------------------------	----------------------------	---------------------	----

